

~~SECRET CONTROL~~

INVESTIGATION REPORT ON SPECIAL EQUIPMENT

OFFICE OF STRATEGIC SERVICES

Ensign Kelly O'Neill, U.S.N.R.  
Maritime Unit

Lieutenant Louis P. Zelenka, C.E.  
Research and Development

APPROVED FOR RELEASE  
DATE: MAY 2001

~~SECRET CONTROL~~

NND 971445 Doc. 20

~~SECRET CONTROL~~

INVESTIGATION REPORT OF SPECIAL EQUIPMENT  
OF THE MEZZI D'ASSALTO GROUP  
OF THE ITALIAN NAVY

TO  
DIRECTOR  
OFFICE OF STRATEGIC SERVICES  
WASHINGTON, D. C.

FOR  
OFFICIAL ACTION

SUBMITTED BY

ENSIGN KELLY O'NEALL, U.S.N.R.  
MARITIME UNIT

LIEUTENANT LOUIS P. ZELENKA, C. E.  
RESEARCH AND DEVELOPMENT

~~SECRET CONTROL~~

TABLE OF CONTENTS

SYLLABUS

I. SCOPE

II. AUTHORITY

III. GENERAL DISCUSSION

MPSM BOAT  
MTM BOAT  
CHARIOT SLC - (3)  
CHARIOT SEM - (7)  
KANGAROO  
GAMMA EQUIPMENT  
PERSONNEL

IV. CONCLUSIONS

V. RECOMMENDATIONS

APPENDIX

OPERATIONAL CHART

DRAWINGS

MTSM - (3 views)  
MTM - (top view)  
CHARIOT S.L.C. - (3) (side view)  
CHARIOT S.B.M. - (7) (side view)

PHOTOGRAPHS

PARAPHRASE

~~SECRET CONTROL~~

SYLLABUS

This report covers an investigation of the special equipment and personnel of the Mezzi d'Assalto Group of the Italian Navy. The purpose of this investigation was two-fold. First, it was to determine if any of the special equipment and personnel reported herein could be of value to the Maritime Unit, Office of Strategic Services, in Southeast Asia or the Far East. Second, the purpose of this investigation was to ascertain if any of the special equipment and personnel of the Mezzi d'Assalto Group were procurable for duty with the Maritime Unit in Southeast Asia or the Far East.

The special equipment reported herein includes four types of weapons. These are: the Italian midget torpedo boat; the Italian explosive motor boat; the Italian "human torpedo" or "Chariot" and the Gamma or Italian underwater swimmer's equipment. The writers believe that the Maritime Unit could use all of these weapons advantageously against Japan if native personnel can be trained or Italian operational personnel can be procured.

To judge the value of these special weapons, the writers studied the operational records of the Mezzi d'Assalto Group. These records reflected that from 1940 to 1943 this group sunk 237,000 tons of shipping including 4 capital ships. All of the four weapons above named were employed in sinking this tonnage.

~~SECRET CONTROL~~

~~SECRET~~

The Mezzi d'Assalto Group, at the present time, has on hand a limited supply of their special equipment. This includes:

9 each MTSM's (midget torpedo boats)

13 each MTM's (explosive motor boats)

2 each "Chariots" ("Human torpedoes")

Gamma equipment, non-expendible, complete, for  
5 each operators

Gamma equipment, expendible, complete, for 1  
operation

Some of this equipment is in need of repairs, but the chief engineer of the Mezzi d'Assalto Group states that these repairs can be completed within 7 days if O.S.S. will supply the necessary materials.

The Italian Ministry of Marines has unofficially approved the transfer of all or part of this equipment to the Office of Strategic Services if the transfer meets with the approval of Allied Armies in Italy and the British Royal Navy.

The personnel of the Mezzi d'Assalto Group is highly trained and operationally experienced in the use of this special equipment. They are eager to be employed by the Maritime Unit for either instructional or operational duties in the Far East.

Due to the fact that Italy is not at war with Japan, Mezzi d'Assalto personnel in the capacity of members of the Italian armed forces, can not be used operationally in S.E.A.C. or the Far East. The writers believe that this personnel might be used operationally if they can be given some special American

~~SECRET~~  
status with the approval of the Italian Ministry of Marines.

The Italian Ministry of Marines has unofficially approved the loan to O.S.S. of all or part of the Mezzi d'Assalto personnel for instructional duties in the Far East. Official approval for the loan of this personnel is being withheld until O.S.S. requests Allied Armies in Italy and the British Royal Navy to grant approval.

The writers strongly suggest that special negotiations be conducted between O.S.S. and the Italian Ministry of Marines to obtain Mezzi d'Assalto personnel for operational duty in the Far East. It is particularly desirable to obtain this personnel because it is already highly trained and operationally experienced in the use of the special weapons herein reported. The training of new personnel in the use of this equipment would require a considerable period of time.

The principal recommendations of this report are:

- (1) that O.S.S. procure from the Mezzi d'Assalto Group for duty in the Far East all of the special equipment reported herein;
- (2) that O.S.S. procure 6 each special equipment instructors and 3 each special equipment maintenance technicians from the Mezzi d'Assalto Group for instructional duties in the Far East;
- (3) that O.S.S. conduct special negotiations with the Italian Ministry of Marines to obtain 20 each special equipment operators and 6 each special equipment

~~SECRET~~  
maintenance technicians from the Mezzi d'Assalto Group  
for operational duties in the Far East;

- (4) that the Maritime Unit, O.S.S., either procure the  
manufacture of, or purchase from the British on reverse  
lend-lease several types of Italian Gamma equipment for  
the use of American underwater swimmers.

INVESTIGATION REPORT OF SPECIAL EQUIPMENT  
OF THE MEZZI D'ASSALTO GROUP  
OF THE ITALIAN NAVY

20 February 1945

I. SCOPE

This report covers an investigation of the special maritime equipment and personnel of the Mezzi d'Assalto group of the Italian Navy. This investigation was made at the base of the Mezzi d'Assalto group which is at San Vito Bay near Taranto, Italy. This investigation was made from 31 January to 5 February 1945.

This report covers the characteristics and physical condition of the equipment seen at San Vito. It also contains recommendations for the employment of this equipment by the Maritime Unit of the Office of Strategic Services in Southeast Asia.

This report covers the personnel and past operations of the Mezzi d'Assalto group. In it are recommendations for the employment of this Italian personnel by the Maritime Unit, S.E.A.C.

This report includes photographs of all the equipment and some of the personnel of the Mezzi d'Assalto group. Drawings of some equipment are included. Photographs and drawings may be found in the appendix.

II. AUTHORITY

This investigation was made and this investigative report has been compiled in compliance with a verbal order given by



Major General W. J. Donovan, Director, Office of Strategic Services, Washington, D. C.

This investigation and report have further been made in compliance with a written order from Lieutenant Colonel C. M. Wood, Chief of Operations, M.T.O., to Ensign Kelly O'Neill, Maritime Branch.

This written order authorized Ensign O'Neill to request technical assistance in making an investigation and compiling a report.

Technical assistance was verbally requested from the Research and Development Branch of the Office of Strategic Services. Lieut. Louis P. Zelenka, R. and D. Branch, was verbally assigned as technical adviser for the investigation and report.

NOTE:

It has been officially requested by the Chief of Staff and Operations of the Mezzi d'Assalto group that past operations of the group referred to, in this report, be regarded as top secret. This is due to the fact that many operations referred to herein were carried out against a nation with which Italy is presently co-belligerent.

III. GENERAL DISCUSSION OF INVESTIGATION

1. MPSM

- (a) The MPSM is an Italian midget torpedo boat. It is used by the Italian Navy, primarily for "hit

and run" operations against enemy shipping and marine installations.

Description

(b) This midget torpedo boat is constructed of mahogany wood with metallic dual cock pit type cabin. Its overall length is 23 feet 8 inches and its beam is 6 feet 8 inches. The draft of this boat is 1 foot. The height of this MTSM from keel to deck level is 5 feet 9 inches. This craft displaces  $3\frac{1}{2}$  tons complete with torpedo. The deck of the MTSM is slightly cambered. The dual cockpit type cabin is located aft of the bow by approximately  $\frac{1}{3}$  of the distance from bow to stern. One hatch is located forward of the cockpit. The hatch covering the torpedo tube extends from 2 feet aft of the cockpit to the stern. One engine hatch is located on either side of the torpedo tube. A radio antenna is located directly forward of the cockpit. The maximum speed of the MTSM is 34 knots. The range of this boat is 80 miles per a continued speed of 34 knots or 120 miles per a continued speed of 32 knots. The MTSM is unsuitable for the open sea in winds of more than force 2-3.

The Engine, Propeller and Accessories

(c) The MTSM is powered by 2 gasoline engines of 95 horsepower each. These engines are of Alpha Romeo design and can be operated individually or synchronized to operate harmoniously together. Each engine has 2 carburetors and its own complete assembly. Each engine drives one propeller. Both propellers and propeller shafts are completely retractable so that the MTSM can pass freely over obstructions. The 2 gasoline engines use high octane gasoline.

Three gasoline tanks are symmetrically located aft of the cockpit. Each full tank has a capacity of 90 gallons. Additional fuel tanks can be attached to the deck.

Two exhaust transoms are located just below deck level at the stern. One transom is located to port and one to starboard. The location of these transoms above the water line omits much of the noise which is usual with small craft at low speed.

The Cabin and the Steering Gear

(d) The dual cockpit type cabin is located aft of the bow by approximately 1/3 of the distance from bow to stern. The semi-streamlined superstructure of

the cabin rises approximately  $2\frac{1}{2}$  feet above deck. Two hatches are located on the topside of the cabin superstructure and serve as entrances to the cockpit. This cabin is approximately 5 feet deep from the top of the cabin hatch to the deck of the cabin.

The cabin of the MTSM is equipped with dual control steering and piloting gear. The radio telephone and radio telegraph equipment are located in the cabin. The torpedo release lever is conveniently located on the floor between the 2 steering wheels.

#### The Torpedo and Torpedo Tube

(e) The torpedo tube is parallel to the keel and extends from 2 feet aft of the cabin to the stern. This tube is slightly more than 18 inches in diameter. The after end of the torpedo tube is enclosed by a round aluminum door which is centered on the stern. The torpedo tube door is opened to discharge the torpedo, but it cannot be opened when the propellers are in the fully retracted position.

The torpedo is discharged by a pneumatic ram which is situated in the torpedo tube. An independent unit air compressor(3 stroke) gasoline engine builds up the necessary pressure. The required pressure can be built up en route to the target.

(f) The torpedo used by the MTSM is a special type. It is 18 inches in diameter and 10 feet 6 inches in length complete with warhead. This torpedo is driven by compressed air at a speed of 32 knots. Its maximum range is 6000 feet and its recommended or accurate range is 3000 feet. This torpedo is carried in the torpedo tube.

Defensive Equipment of the MTSM

(g) The defensive weapons of this boat are intended to aid in making a safe withdrawal after the "hit and run" attack.

Two special depth charges which are similar to the American Navy's "K" gun are mounted aft of the cabin. These depth charges are used against pursuing surface craft. This charge is equipped with a lead weight delay mechanism which becomes detached when the charge sinks to a set depth. After detaching itself from the lead weight, the charge rises to an approximate 12 foot depth and automatically detonates.

Smoke screen equipment can be used by the MTSM. The type of smoke screen equipment used by the Italians is a spherical float which is 12 inches in diameter. It creates a smoke screen which lasts 15 minutes.

The 2 operators carry small arms and hand grenades for additional protection.

#### The Operators

(h) The MTSM is operated by 2 men who may sit or stand in the operator's cabin. Operators usually stand with head and shoulders protruding above the topside of the cabin hatches in order to have adequate visibility.

Each operator has a complete set of steering and piloting controls before him. The operators may alternate control of the boat.

#### Transportation of the MTSM

(i) The MTSM may be transported aboard or towed behind a mother craft to increase its range. The Italian Navy uses a specially fitted MS boat (Italian P.T. boat) known as a "Kangaroo" to transport the MTSM. The "Kangaroo" is fitted to carry one MTSM. The Italian Navy has successfully transported MTSM boats overland by truck to increase their range. A 2½ ton truck with special fittings will carry one MTSM.

#### Operational Technique

(j) The Italian Navy usually uses MTSM boats in groups of 3 or more and often in conjunction with MTM explosive motor boats. The ordinary practice is for the MTM boats to attack the harbor nets and

booms and make an entrance into the harbor for the MTSM boats. The attack inside the harbor is carried out by the MTSM boats at top speed. The operators maintain a course toward the selected target until the boat comes within torpedo range. The operator then makes a tight 180 degree turn and discharges the torpedo from the stern of the MTSM. After firing the torpedo, the operator heads for the open sea, using the defensive weapons if necessary.

2. M.T.M.

- (a) The MTM is an Italian explosive motor boat. This boat is used principally for operations against enemy shipping and marine installations.

Description

- (b) The MTM is constructed of mahogany wood. Its overall length is 18 feet and its beam is 5 feet 6 inches. This explosive motor boat has a draft of 7 inches.

The pilot's cockpit is located at the stern. The deck of this boat is slightly cambered from 3 feet aft of the bow to the stern. There are two hatches. The forward hatch covers the explosive compartment and the aft hatch covers the engine compartment.

- (c) The maximum speed of the MTM is 30 knots. The maximum range at a continued speed of 30 knots is 70 miles.

miles. At a continued speed of either 6 knots or 28 knots, the extreme range of the MTM is 80 miles in calm water. In a moderately choppy sea the range of the MTM is 40 miles. A wind of force 1-2 is maximum for safe operational work.

The Engine, Propeller and Accessories

(d) The MTM is powered by one 90 horse-power Alpha-Romeo gasoline engine. This engine is located athwartships in the engine compartment. This engine operates one propeller. The propeller and propeller shaft are retractable to permit this craft to pass over an obstruction.

The transmission is so designed that the drive is taken through an oil operated friction clutch incorporating a reverse gear.

The throttle can be rapidly placed in either the full ahead or full astern positions and the drive is taken up gradually. This simplifies handling the MTM in restricted waters.

The MTM uses high octane gasoline. There are 2 gasoline tanks, each with a capacity of 13 gallons.

One fuel tank is located on the port side of the engine and the other on the starboard side.

The exhaust transom is just below deck level on the port side of the stern. This transom is above



the water line to eliminate the noise made by an underwater exhaust transom.

#### The Pilot's Cockpit and the Steering Gear

- (e) The pilot's cockpit is located at the stern and accommodates one man. It is 2 feet 6 inches square and extends 6 inches behind the stern. It is surrounded on its port, starboard and forward sides by a metal combing (cowling). This combing rises approximately 12 inches above the deck.
- (f) The steering gear and navigational equipment are located in the pilot's cockpit. This gear includes the steering wheel, the throttle, the instrument panel and compass. The following levers are located in the pilot's cockpit: the "propeller retracting" lever, the "cocking" lever and the "detonation choice" lever. These levers will be discussed later in this report.

#### The Pilot's Escape Raft

- (g) The pilot's escape raft is attached to the afterside of the cockpit. This raft is constructed of two pieces of wood which are each 2 feet 6 inches square and 4 inches thick. These pieces are hinged together. The two pieces hinge out or open to make a floating raft 5 feet in length by 2 feet 6 inches in width. When being carried at the

stern, the raft is doubled up into a 2 foot 6 inch square. The release of the escape raft is controlled by the "cocking lever" located in the pilot's hatch. The escape raft, when in a carrying position, forms the afterside of the pilot's cockpit.

The Explosive Charge and Detonating Mechanism

- (h) The weapon of the explosive motor boat is a special depth charge weighing 660 lbs. This depth charge is cylindrical in shape and is similar in appearance to a 55 gallon oil drum. It is mounted in the explosive compartment 4 feet aft of the bow. The "detonation choice" switch may be set to detonate the charge either hydrostatically or instantaneously.
- (i) Three small "breakup" charges are situated 1 foot aft of the main charge, one charge to starboard, 1 charge to port, and 1 charge athwartships. Detonation of these charges causes the MTM to break up just aft of the main charge. These breakup charges are connected electrically with the Bumper mechanism.
- (j) The Bumper mechanism consists of 2 parts, the Bumper frame and the Bumper switch. This mechanism enables any part of the forward quarter of the MTM to strike

the target and cause detonation.

The Bumper frame consists of a tubular steel frame which is shaped to follow the bow line of the boat. This frame lies flat on the deck and projects 6 inches all around the gunwhale. It is held in position by guides which allow it to be moved backward, forward or sideward. The Bumper frame is connected to the second part of the Bumper mechanism which is the Bumper switch or initiator. This electric switch is located athwartships and under the after edge of the Bumper frame. When the Bumper frame strikes its target, the electric circuit of the Bumper switch is opened and the "break-up" charges are electrically detonated.

- (k) The anti-boom lever is an extension of the Bumper frame. It is 3 feet in length and has a hooked end. The anti-boom lever is hinged at its topside to the forward end of the Bumper frame. It extends 18 inches below the surface of the water when in use. When not in use it is hinged back so that it lies along the deck of the bow parallel to the keel. The pilot releases the anti-boom lever from its stowed position by means of a wire terminating in the pilot's hatch. When it is in a perpendicular position, contact of the anti-boom lever with

any harbor boom or net will cause the Bumper frame to move. The movement of the Bumper frame initiates detonation of the "breakup" charges and the main charge. Instantaneous firing is used for this operation.

- (l) The "cocking" lever in the "cocked" position simultaneously does the following: closes the firing circuit of the Bumper switch; starts a 4 minute time fuse which will detonate the main charge if the MTM does not strike its target; and releases the operator's escape raft. When this lever is in the "uncocked" position the Bumper switch is inactivated.
- (m) The main charge may be detonated in two ways, hydrostatically or instantaneously. If the main charge is set for hydrostatic detonation, the breakup of the MTM permits the charge to sink beneath its target where it detonates. If the main charge is set for instantaneous detonation, it is electrically exploded when the Bumper frame strikes the target. The "detonation choice" lever, which is located in the cockpit, selects the type of detonation desired by the operator.

The Operator

- (n) The MTM is operated by one man who stands or

~~SECRET~~

squats inside the cockpit located at the stern. This operator's head and shoulders protrude above the cockpit for visibility. This pilot is clothed in a special suit of rubberized waterproof material which is identical with the suit worn by the "chariot" operator. Underwater breathing apparatus is not used. This operator is attached to his escape raft with a rope.

Operational Technique

- (o) The Italians carry out the attack inside the harbor at a speed of 20 to 25 knots. They believe that this speed is the most accurate steering speed. The MTM operator directs the course of the boat until it reaches a point 600 to 900 feet from the selected target. At this point the operator "freezes" the steering gear so that the MTM will maintain a collision course with the target. The operator simultaneously pulls the "cocking lever" and jumps out of the boat. He must pull at least his head and chest out of the water and onto his escape raft before the main bursting charge detonates.
- (p) When the operator of this boat desires to "jump" a boom he approaches at slow speed. If the buoys

~~SECRET CONTROL~~

of the boom are far enough apart and the upper cable is below the surface, the operator raises the propeller to minimum depth necessary for propulsion and drives slowly through. If it is necessary to tilt the drive more than 45 degrees, the normal steering apparatus will not function. In this case, the boat, moving very slowly, is steered by means of an oar which is carried for the purpose. This boat can be steered with an oar even when it is necessary to place the drive in a horizontal position.

If the top cable of the boom is above the surface, 2 boats must work together. Two pilots get in one boat, taking the extra boat in tow. At the boom cable, the driver of the towed boat gets out of the towing boat to stand on the top boom cable. He supports himself against the bow of the towing boat. The pilot of the towing boat places the throttle in neutral and raises his propeller. He then gets out of the boat and also stands on the boom wire. The weight of the two men depresses the boom cable. The two men pull the boat over the wire by means of handles running from the bow to a point abreast of the engines. The process is then repeated for the towed boat.

### 3. The "Chariot"

(a) The Italian "Chariot" or "Human Torpedo" is known as the SEM (3). This special naval equipment is used by the Italian Navy to attack enemy shipping and marine installations. The design of the "Chariot" is a combination of the torpedo and the midget submarine.

#### Description

(b) This "Chariot" is constructed of welded sheet steel with a wooden superstructure. It resembles a torpedo. The overall length of this "Chariot" is 22 feet 3 inches. The diameter of the steel body is 1 foot 7 inches. The maximum height of the superstructure from the top of the main body is 2 feet and 5 inches.

(c) This "Chariot" has a speed of 2.2 knots and a range of 17 miles. It cannot operate below a depth of 45 feet and must operate in calm seas.

(d) The cylindrically shaped body of the "Chariot" is divided into 4 separate compartments which are from fore to aft:

- (1) Warhead or explosive charge
- (2) The battery compartment
- (3) The engine and pump compartment

(4) The tail mechanism and tail assembly.

There are two dead air chambers. The forward dead air chamber is located between the warhead and the battery compartment. The aft dead air chamber is located between the motor and pump compartment and the tail assembly.

Warhead

- (e) The compartment containing the explosive charge or warhead is 6 feet 6 inches long. The warhead is located at the most forward section of the body of the "Chariot." Its forward part is shaped like the nose of a torpedo. This warhead is removable. Its detachment is controlled by a hand lever which is located in the forward pilot's compartment. The main bursting charge weighs 595 pounds. This charge can be fitted with an adjustable delay mechanism or with a horn and anchored as a mine.

Battery Compartment

- (f) The battery compartment is situated aft of the warhead. This compartment is approximately 7 feet 6 inches long and is cylindrical in shape. This compartment contains 8 units of complete Italian submarine batteries. These batteries are located in the aft 5 feet of the compartment. This compartment



is separated from the warhead by the forward dead air chamber.

Engine Compartment

(g) The motor and pump compartment is located aft of the battery compartment and forward of the tail assembly. This compartment is approximately 3 feet 7 inches long and is cylindrical in shape. It is sealed from the battery compartment by a steel bulkhead. The electric power unit and the pump which are housed in this compartment are similar to the ones used in large scale submarines.

Tail Assembly

(h) The tail assembly is located aft of the motor and pump compartment and is separated from that compartment by the aft dead air chamber. The tail assembly houses the propeller shaft which is concentric at the center and guided directly to the vertex. This elongated spherical cone section is known as the complete tail assembly. It is approximately 4 feet 5 inches in length. This section supports the tail mechanism.

The tail mechanism consists of the rudder and elevator apparatus. The propeller is located at the vertex of the cone. The propeller is protected

~~SECRET~~

by a cylindrical plinth cowling which also reinforces the stabilizers and fins of the tail mechanism. The complete tail mechanism is 1 foot 10 inches in length from tip to tip of the rudders or tip to tip of the elevator.

- (i) The superstructure consists of 3 wooden sections which are integrated with the torpedo body.

(1) The forward superstructure is convex in shape. It is approximately 2 feet 5 inches in height. At the base, this structure is 1 foot 6 inches and at the top it is 1 foot 2 inches. The forward superstructure is located over the forward section of the battery compartment. This superstructure was designed to give the forward pilot some protection from the wind and the waves and to serve as a protective cowling over the steering apparatus.

(2) The midships superstructure rests approximately over the center of the battery compartment. It is approximately 1 foot 6 inches in height from the torpedo body. It is 1 foot 6 inches wide at the base and 1 foot 3 inches wide at the top.

This structure provides a back rest for the forward operator and a protection from wind

and waves for the aft operator.

The immersion chamber is fitted inside the midships superstructure. This chamber is filled with water when the chariot is submerged. When the water is released from this chamber the "Chariot" comes to the surface. This chamber is controlled by a hand lever.

(3) The after superstructure is almost non-functional. It provides a back rest for the aft operator. This structure is 1 foot 6 inches in height from the steel body. It convexly curves down to the main body towards the tail assembly for stream lining.

#### Steering and Navigational Apparatus

(j) The steering gear and navigational apparatus are located under the cowling formed by the forward superstructure. One universal hand lever directs the course of the "Chariot" both horizontally and vertically. The instrument panel includes a compass.

#### The Operators

(k) The "Chariot" is operated by 2 men. The forward operator sits between the forward and midships superstructures. He handles the steering gear and navigational equipment. The aft operator sits between the midships and aft superstructures. He

handles the lever which controls the immersion chamber. This lever is located on the after side of the midships superstructure.

Special Clothing and Underwater Breathing Apparatus

(1) The "Chariot" operators wear waterproof clothing and special underwater breathing equipment.

(1) The waterproof clothing is made in 3 pieces. These include pants, shirt and outer garment.

The pants are made of light weight India rubber. They are equipped with feet and reach to the arm pit. These pants fit the body snugly. The shirt is made of light weight India rubber. It has long sleeves and a high neck. This shirt seals around the skin of the wrists and neck to make the garment waterproof. It fits the body snugly. The outer garment is made of rubberized linen. It is attached to the 2 inner pieces. This outer garment is equipped with feet and fits tightly around wrists and neck. The outer garment fits the body snugly. This garment buckles down the front.

Long woolen underwear, extra weight, is worn under the rubber inner garments.

The special shoes worn by the "Chariot" operators are similar to American galoshes. (2) The "Chariot" operators wear underwater breathing units. These diving units are similar to the OSS Lambertson Unit. These units consist of a head piece, and an oxygen unit. The oxygen unit is worn on the chest. It is connected to the face and head piece with a rubberized tube.

Transportation of the "Chariot"

(m) The "Chariot" may be transported by specially fitted submarine or by a specially fitted Italian P.T. boat known as the "Kangaroo." The "Chariot" may be carried aboard any surface craft as large as an American P.T. Boat or be transported overland by any 2½ ton truck.

Operational Technique

(n) The Italians launch the "Chariot" from the mother craft 8 to 10 miles distant from the target. The distance between the mother craft and the harbor net may be navigated either submerged or on the surface. The "Chariot," due to its special design, will frequently pass through a harbor net. If the operators have difficulty passing the "Chariot" through the net, a silent pneumatic cable cutter

is used. This cable cutter is discussed in this report in connection with Gamma equipment.

The approach to the target inside the harbor is made with the "Chariot" submerged. The operators navigate the "Chariot" under the keel of the target ship. Hooks or magnets are attached to the bilge keels of the target vessel and lengths of cable are attached from the hooks to the warhead of the "Chariot." The warhead is detached from the "Chariot" by means of the hand lever in the forward pilot's seat. It remains under the keel of the target ship, supported by the cables and hooks. The operators start the delay mechanism of the warhead and retake their positions in the "Chariot" to leave the harbor.

The warhead of the "Chariot" may also be anchored to the bottom of the harbor and used as a mine.

4. THE S.B.M.(7)

(a) The S.B.M.(7) or "New Chariot" is a combined midget submarine and torpedo. This midget submarine will be referred to throughout this report as S.B.M.(7).

(b) No models of the S.B.M. (7) have been produced but plans have been completed and are ready for production of a sample and experimental model. This

model has not previously been produced by the  
Italians due to the lack of materials.

- (c) The SBM(7) has the appearance and general lines of the "Chariot." It is constructed of welded sheet steel. The plans provide for an optional overall length of 28 feet, 1 inch, or 26 feet, 11 inches. The cylindrically shaped body of the SBM(7) has a diameter of 2 feet 8 inches. A streamlined superstructure is centered on the top side of the main body and covers the entire midsection of the body. The designed speed of the SBM(7) is  $4\frac{1}{2}$  knots and the designed range is 47 miles. It is expected to operate below a depth of 45 feet. The SBM(7) can only operate in smooth seas.
- (d) The cylindrical main body of the SBM(7) is divided into separate compartments. These compartments from fore to aft are: the explosive charge or warhead; the operator's compartment; the battery compartment; the motor and pump compartment and the tail mechanism.

Warhead

- (e) The compartment containing the warhead is 5 feet 9 inches in length. It is cylindrical in shape with a diameter of 2 feet 8 inches. The forward part of this compartment is rounded like the nose

~~SECRET CONTROL~~

of a torpedo. This warhead may carry 1 charge of 1323 lbs. or 2 charges of 661 lbs. each.

Operator's Compartment

(f) The operator's compartment is aft of the warhead. It is separated from the warhead by the forward dead air chamber. This compartment is cylindrical in shape. It is 5 feet in length and has a diameter of 2 feet 8 inches. This compartment encloses all of the steering gear and navigational equipment.

Battery Compartment

(g) The battery compartment is located aft of the operator's compartment. It is separated from the operator's compartment by a steel bulkhead. The battery compartment is cylindrically shaped. It is 8 feet long and has a diameter of 2 feet 8 inches. This compartment is designed to contain 40 Italian submarine batteries.

Motor and Pump Compartment

(h) The motor and pump compartment is aft of the battery compartment and is separated from it by a steel bulkhead. This compartment is cylindrical in shape. It is 2 feet 10 inches long and has a diameter of 2 feet 8 inches. It contains electric motor and pump equipment which is similar to that used in a large scale submarine.

~~SECRET 25 - CONTROL~~



The Tail Mechanism

- (i) The tail mechanism is located at the stern and aft of the motor and pump compartment. This compartment is separated from the motor and pump compartment by the aft dead air chamber. The design of the tail mechanism is the same as for the "Chariot."

The Superstructure

- (j) The forward superstructure rises 1 foot 3 inches above the main body. It is located over the operator's chamber. The forward part of this structure curves smoothly into the main body.
- (k) The aft superstructure rises approximately 11 inches above the main body. It is located over the battery compartment. It joins the forward superstructure. The aft section of the aft structure curves smoothly into the main body. The aft superstructure is non-functional.
- (l) The immersion chamber is located in the forward section of the forward superstructure. It is controlled from the operator's compartment.
- (m) The operator's escape hatch occupies the after section of the forward superstructure. The escape hatch is equipped with a special roll-back door.

The Operator

- (n) This SEM(7) is operated by 2 men who occupy the operator's compartment.

~~SECRET CONTROL~~

(o) Operators of the SBM(7) wear the same diving helmets and special clothing worn by the "Chariot" operator.

Operational Techniques

(p) Operational techniques cannot be given for the SBM (7) as no model has been produced. It is assumed that the methods of transportation and approach would be similar to methods already discussed in connection with the "Chariot." The warhead of the SBM(7) is detachable and would be used operationally in exactly the same manner as the warhead of the "Chariot."

Improvements of SBM(7) over the "Chariot."

(q) The principal improvements of the SBM(7) upon the "Chariot" are: the enclosed pilots' compartments; the larger charge of the warhead; and the greater speed and range.

5. GAMMA

Gamma equipment is the general term given to all equipment used by American or Italian underwater swimmers. It is designed to enable the underwater swimmer to operate more efficiently.

The Breathing Apparatus

(a) The Breaching Apparatus of the Italian Gamma men or underwater swimmers has been cut down to the

27  
~~SECRET CONTROL~~

~~SECRET~~

bare essentials. This apparatus consists of a breathing bag, a mouth piece, a nose clip, a canister of CO<sub>2</sub> absorbent and an O<sub>2</sub> bottle.

The breathing bag encloses a rubber diaphragm. The outside of this bag is constructed of canvas. This bag is worn high on the operator's chest and has straps that attach around the neck and waist. A rubber tube which connects the breathing bag and mouth piece extends from the top of the breathing bag.

The mouth piece is made of rubber. It is attached to one end of a rubberized tube which leads to the breathing bag. When the mouth piece is inserted in the mouth, the swimmer is able to breath comfortably.

The nose clip is constructed of metal and rubber. One section of the clip fits near the opening of each nostril while the remainder of the clip squeezes the outside of the nose just below the bridge. This clip is similar to the type often worn by Olympic high divers.

The canister of CO<sub>2</sub> absorbent is located inside the breathing bag. The oxygen bottle is attached to the underside of the breathing bag. Only pure oxygen is used.

~~SECRET~~

This breathing unit is equipped with a shut-off valve, and a constant flow and by-pass valve. These are located on the breathing bag for convenience. This unit is designed for underwater work not to exceed 45 minutes duration.

GAMMA Clothing and Accessories

(b) Italian Gamma men wear special clothing for underwater work.

(1) The Underwater Swim Suit is made of light weight India rubber and fits the skin tightly. This suit consists of 3 pieces. The trousers have enclosed feet and reach to the armpits. The top piece resembles a ski-vy shirt (T-shirt) in cut and extends below the crotch. It has short sleeves which fit tightly around the biceps. A rubber collar adheres to the skin around the neck. The third piece of the swim suit is the cummerbund which resembles a large rubber band. After the Gamma man is dressed with trousers and top-piece of the swim suit, he folds the overlap of these 2 pieces to make a thick layer of folded rubber at the waist. The cummerbund is worn over the rubber layers at the waist.

(2) The limpet's vest is made of canvas. This vest extends almost to the operator's crotch and

is sleeveless. It buckles down the front. This vest is equipped with 5 rings for carrying limpets and a loop for carrying a sheathed knife.

(3) The Gamma man is equipped with an eye piece which is primarily designed to protect the eyes from the salt water and not to aid vision. This eye piece is a circular piece of glass approximately 6 inches in diameter. It is mounted on a rubber cushion which adheres to the face and is held in position on the forehead with a rubber band.

(4) The Gamma man is supplied with a head net for camouflage. This net is blue-green in color and is approximately 3 feet square. It is worn over the head. This net is designed to permit a swimmer to come to the surface for observation without being detected.

(c) The Italian Gamma men use the American-made foot fin. This is the same type fin used by American under-water swimmers. (These fins are manufactured by the Owen-Churchill Rubber Company at Los Angeles.) No hand fins are used.

(d) A special underwater compass is used by the Italian Gamma men. This compass is worn on the wrist like a wrist watch. It is equipped with luminous

~~SECRET~~

figures and an optical prism. The purpose of this prism is to permit the swimmer to read his magnetic course while swimming on his back.

The Rubber Boat and Floats

(e) The Gamma men have 2 means of approach to a target. These means consist of the rubber boat and the Matarrassino.

(1) The rubber boats used by the Italians are similar to those already used by this organization.

(2) The Matarrassino is an inflatable rubber float which is constructed of rubberized canvas. It is 5 feet in length and its beam is 2 feet. It weighs 10 pounds. At the bow of this float is a chin rest which protrudes 4 inches above from the deck. On the starboard side of the chin rest is a built-in bellows which is used to inflate the Matarrassino. A metal deflation tube with stopper is located at the center of the chin rest. A pocket for carrying small articles is located on the after side of the chin rest. When the Matarrassino is deflated and rolled up, it forms a packet 16 inches in length by 10 inches in width by 6 inches in height.

The Matarrassino carries one man. This man lies face downward and propels the raft with his hands and arms.

~~SECRET CONTROL~~

The built in bellows make it possible to inflate without difficulty while both the Matarrassino and the swimmer are in the water.

The principal use of this float is to increase the range of the underwater swimmer.

(3) The Italian Navy has developed a gasoline motor for use in a rubber mattress which is similar in design to the O.S.S. rubber mattress. This motor is a small gasoline unit. It consists of one cylinder which drives a 5 foot shaft with a 6 inch propeller. The gasoline tank contains 1/2 gallon of fuel.

This motor is not used because it produces too much noise. The Italians state that the Germans have redesigned this unit and developed a noiseless motor.

Italian Limpets

(f) The Italian Gamma men use two types of limpets. One is a magnetic type and the other a pneumatic type limpet.

(1) The Italian and the American magnetic limpets are similar in construction and operation. This Italian magnetic limpet is rectangular in shape and is constructed of brass. It is 2 3/4 inches

~~SECRET CONTROL~~

by 2 3/4 inches by 10 inches. This limpet contains 4 pounds of plastic explosive. It is equipped with six crescent shaped magnets. This Italian limpet has a brass time delay detonator which is embedded into the plastic explosive in the container. The fuze does not protrude from the limpet.

(2) The pneumatic or Mae West limpet is an explosive charge which employs the suction principle for adherence to its target. It is circled by an inflatable rubber tube which is similar to an automobile balloon type tube. A cross-section of this tube inflated is approximately 5 inches in diameter. The diameter of the Mae West limpet complete with the mine and inflated tube is approximately 17 inches. A vial of compressed air is contained within the Mae West tube. The tube is inflated by breaking the vial of compressed air. This tube circles a metallic canister which is a hemisphere in shape. This canister contains 10 pounds of explosive which is ignited by an electrical time mechanism with a dry cell battery. This mechanism is inserted into the canister. There are 3 different fixed time delay igniters, one for 30 minutes, one for 2 hours, and one for 4 hours.



The Mae West tube and the explosive canister are attached by means of canvas straps.

Transportation

- (g) Gamma men and their equipment can be transported within striking distance of the target by submarine, MTSM, MIM, any small surface craft or by land transport. The MTSM and MIM have a limited range but are especially fitted for this work because of their shallow draft.

The Silent Net or Cable Cutter

- (h) The Italian cable cutter is designed to cut under water cables up to 2 inches in diameter. It is a pneumatic powered piece of equipment which is operated by one "Gamma man."

The Italian cable cutter has two ellipsoid metallic containers. One canister contains oxygen. It is approximately 8 inches in diameter and 12 inches in length. The other canister contains light hydraulic oil fluid. This canister is approximately 3 inches in diameter and 7 inches in length.

These ellipsoid containers are connected with copper tubing. A rubber hose 12 feet long joins the smaller container to the cutting unit. This cutting unit is made up of 2 parts, the clamp and the

~~SECRET CONTROL~~

base. The cable is placed between the clamp and the base. A slip lug bolt holds the base and clamp together and freezes the cable in place. The base is a cylindrical housing. This base houses the cutting knife.

Operational Technique

(i) The operational technique of Italian Gamma men is very similar to that of American underwater swimmers. One noticeable difference in technique is that Italian Gamma men are trained to swim to the target on their backs. The operator often tows floats behind him which bear the operational equipment. Another notable difference in technique is the lesser amount of time the Italian swimmer spends underwater. The Italian breathing unit is designed for only 45 minutes below the surface and the camouflage head net is intended to permit him to float unobserved on the surface.

6. PERSONNEL MEZZI D'ASSALTO GROUP

Organization

(a) The Mezzi d'Assalto group is based at San Vito Bay near Taranto, Italy. The group is a special unit of the Italian Navy. The members of the group at San Vito are only a part of the whole organization. The remaining members are either disbanded and at home or still on the Axis side.

(b) The Mezzi d'Assalto group is divided into four main operational groups, according to the type of weapon employed. These groups are:

- (1) The MTEM group
- (2) The MTM group
- (3) The "Chariot" group, and
- (4) The Gamma group.

In addition to the operational groups, the unit includes 2 groups of technicians. These groups are the surface equipment technicians and the subsurface equipment technicians. The former group of technicians service and maintain the MFSM and MTM boats. The subsurface technicians maintain the "Chariot" and Gamma equipment.

(c) The Commanding Officer and Chief of Operations of the Mezzi d'Assalto group is Captain Ernesto Forza of the Royal Italian Navy. Captain Forza has commanded this group and has been its Chief of Operations since 1939.

Possible Use of Personnel by OSS

(d) Captain Forza recommends the employment by OSS of a basic group of 15 operators and 10 technicians, with more men to be added as needed.

The 15 operators in the recommended basic group include 6 Italian Naval officers and 9 Italian Navy

~~SECRET CONTROL~~

ratings. These men fall into the following groups: 5 operators of MTSM and MTM boats; 5 "Chariot" operators; and 5 Gamma men. All personnel of the basic MTSM - MTM group and the basic "Chariot" operator group have had operational experience. The basic Gamma group is highly trained but without operational experience.

The 10 technicians in the recommended basic group include 1 Italian Naval officer and 9 Italian Naval ratings. The group includes 5 ratings for maintenance of surface equipment and 4 ratings for maintenance of subsurface equipment. The 1 Italian officer is chief technician and engineer for both groups.

All of the officers in the recommended basic group speak enough English to make satisfactory liaison possible.

Availability of Personnel

- (e) Either all or any part of the Mezzi d'Assalto group is available to the Maritime Unit, S.E.A.C., if and when a proper political agreement can be made with the Italian government. The recommendation of Captain Forza is in no way binding and more or less Mezzi d'Assalto personnel can be acquired.

~~SECRET CONTROL~~

~~SECRET CONTROL~~

This personnel is available for either instructional or operational duties, depending on the agreement that can be made with the Italian government. Negotiations are in progress at the present time.

Training of Operational Personnel

(f) The training periods for use of the Mezzi d'Assalto weapons range from 2 to 12 months.

(1) The training period for MFSM and MTM operators is from 2 to 3 months. Excellent seamanship is a prerequisite for a good operator.

(2) The training period for "Chariot" operators is from 6 to 12 months. It is essential that an operator be in excellent physical condition. Operators must be under constant medical observation and must live under strict training regulations.

(3) The training period for Gamma operators is 6 months. Candidates for training should be excellent swimmers. Gamma men should be under constant medical observation and live under strict training regulations.

(4) It is the opinion of Captain Forza that these training periods could not be shortened.

7. OPERATIONAL RECORD OF THE MEZZI D'ASSALTO GROUP

(a) Records of the Mezzi d'Assalto group claim the sinking of 237,000 tons of shipping between August

~~SECRET CONTROL~~

~~SECRET CONTROL~~

1940 and August 1943. Your attention is invited to the Data Chart in the Appendix. All of the special equipment reported herein was employed in the sinking of this tonnage.

- (b) The losses inflicted by the Mezzi d'Assalto Group include 2 battleships, 2 cruisers, 1 destroyer, 1 submarine, 24 steamships, 1 tanker and 3 armored boats. Notable among these losses inflicted are the sinking of the Battleship H.M.S. ELIZABETH by a "Chariot," the sinking of the Battleship H.M.S. VALIANT by a "Chariot" and the sinking of the heavy cruiser H.M.S. YORK by an MTM boat.
- (c) During the period of operations from August 1940 to August 1943, the Mezzi d'Assalto Group lost 39 men killed and 33 men taken prisoners. Two submarines were lost and the full submarine crews were killed. In shipping, the group lost 3 submarines, 1 MAS boat (Italian P.T. boat), and 1 fishing boat.

IV. CONCLUSIONS:

- 1. The Mezzi d'Assalto group at San Vito Bay near Taranto, Italy, has 9 each, M.T.S.M. boats registered at the present time. These M.T.S.M. boats are listed by number below and the amount of repair work and the necessary parts to put these boats in good operational condition are stated. These M.T.

~~SECRET CONTROL~~

~~CONFIDENTIAL~~

S.M. boats have been inspected by the writers. The estimates of repair work are those of the Chief Engineer of the Mezzi d'Assalto group.

(a) The following boat is in excellent operating condition:

M.T.S.M. No. 256.

(b) The following boats are in need of minor repairs which could be completed within 24 hours if the necessary replacements or parts were available:

M.T.S.M. No. 212  
230  
244  
246  
250

NOTE: The new parts required for the repair of the above craft are:

Spark plugs, Italian type rubber hoses, special type gaskets, Italian type electric wires.

(c) The following boats require major repairs which could be completed within 7 to 10 days if the necessary new parts were available:

M.T.S.M. No. 248  
262

NOTE: The new parts required for repair are:

Bearings, special design  
Cylinders, Italian type  
Pistons and rods, Italian type  
Valves, Italian type

~~CONFIDENTIAL~~

Drive shafts and propellers, Italian type

Batteries, special type

Bushings and couplings, Italian type.

- (d) The following boat is heavily damaged and would require considerable repairing before it would be in good operational condition:

M.T.S.M. No. 220

NOTE: The hull of this boat is damaged. Two beams on the port side are broken. The motor is considered to be beyond efficient repair.

- (e) The Mezzi d'Assalto group would repair these boats if they possessed the required equipment and the necessary materials. The chief engineering officer has given the writers some samples of the parts required for these boats. These parts will be sent to Washington for further examination and inspection. Lieut. Zelenka believes that it would take several months to manufacture the required parts. The parts and equipment used by the M.T.S.M. are specially made in Milan, Italy, and no additional parts exist in Allied occupied Italy. It would take several months to manufacture these boats in the United States. Blue prints of the M.T.S.M. can be made if complete and exact information is required and necessary. A sample M.T.S.M. boat

~~CONFIDENTIAL~~



can also be shipped to the United States if it is desired. Negotiations are in progress to procure the operational and repairable boats for the Maritime Unit, S.E.A.C.

2. The Mezzi d'Assalto group has 13 each M.T.M. boats registered at the present time. These explosive motor boats are listed by number and operational condition below. These M.T.M. boats have been inspected by the writers. The estimates of repair work are those of the chief engineer of the Mezzi d'Assalto group.

(a) The following boats are in excellent operating condition:

M.T.M. No. 78  
102  
120

(b) The following boats are in need of minor repairs which could be made in 24 hours if the necessary new parts were available:

M.T.M. No. 52  
72  
90  
106

NOTE: These boats require the same parts listed in the Note following paragraph 1(b).

(c) These boats require repairs to the hull in addition to engine repairs which necessitate new parts. It is estimated that these boats could be repaired

~~CONFIDENTIAL~~

within 7 to 10 days if the necessary new parts and materials were available:

M.T.M. No. 68  
70  
74  
82  
108  
116

NOTE: These boats require the same parts listed in the Notes following paragraph 1(b) and 1(c). They also require mahogany planking and linen for hull repair.

(e) The same statements can be made in conclusion concerning the M.T.M that were made concerning the M.T.S.M. boat. (Refer to paragraph 1(e) for the statements.) It would take several months to manufacture M.T.M. boats in the United States. Blue prints can be made with complete and exact information if it is desired, or a sample M.T.M. boat can be shipped to the United States. Negotiations are in progress to procure the operational and repairable M.T.M. boats for the Maritime Unit, S.E.A.C.

3. The Mezzi d'Assalto group has 3 each "Chariots" registered at the present time. These "Chariots" are listed by number and operational condition. These "Chariots" have been inspected by the writers.

(a) The following "Chariots" are in operational condition:

~~CONFIDENTIAL~~

Chariot No. 2 (British)  
3 (British)

- (b) The following "Chariot" is almost beyond repair and would require considerable special material for repair:

Chariot No. 1

- (c) The Italian "Chariots" were manufactured in northern Italy. No equipment or parts for the manufacture of new Italian "Chariots" is available in Allied occupied Italy. Two of the "Chariots" now used by the Mezzi d'Assalto group were manufactured by the British in England. The British have manufactured other "Chariots," some of which were used in a joint British-Italian operation at La Spezia, Italy.

It would take several months to manufacture models of the "Chariot" in the United States. Blue prints of the "Chariot" can be made if complete information is desired. Negotiations are in progress to procure the 2 operational "Chariots" for the Maritime Unit, S.E.A.C.

NOTE: The S.B.M.(7) or "New Chariot" cannot be discussed because plans have just been completed. No experimental or test model has been produced because the Italian Navy does not have the necessary material.

to construct a sample model.

4.

- (a) The Mezzi d'Assalto group has a limited supply of all types of Gamma equipment mentioned in this report. The Gamma Officer states that the group has enough equipment to completely equip 5 Gamma operators for a mission. He further states that the group has enough limpet mines for one operation. Samples of most of the items described under Gamma equipment in this report are available in the Ordnance Section of the Navy Department, Washington, D.C.
- (b) It is believed by the writers that the following Italian Gamma equipment has no outstanding advantages or disadvantages of efficiency or design over American underwater equipment:
- The underwater swim suit
  - The underwater breathing apparatus
  - The foot fins
  - The underwater compass
  - The protective eye piece.
- (c) It is believed by the writers that the following Italian Gamma equipment is superior or essential:
- The limpet, Mae West type
  - The silent pneumatic cable cutter

The Matarrassino

The camouflage head net

The limpeteers vest.

(1) The limpet, Mae West type, has been adopted by the Italian Gamma Men in preference to the magnetic type limpet mine due to its greater efficiency.

The limpet mine, Mae West type, can be used against concrete or wooden targets. It is believed that O.S.S. has no limpet mine which is adaptable for use against concrete or wooden targets.

(2) The silent pneumatic cable cutter is believed to be the only silent cable cutter that has been developed. It is known that O.S.S. has tried without much success to develop a silent cable cutter for the use of American underwater swimmers.

(3) The writers believe the Matarrassino could be employed by O.S.S. in the following manner:

- a. To assist and increase the range of underwater swimmers.
- b. To enable men from canoes or other surface craft to land through heavy surf, with a small quantity of equipment.
- c. To enable O.G. teams to carry a small float for fording rivers and other water obstacles.
- d. To provide a small float for water reconnaissance or for any type of clandestine operation.

(4) The camouflage head net is believed to be a highly satisfactory device for enabling an underwater swimmer to come to the surface without being conspicuously noticed.

(5) The limpeteer's vest is believed to be both useful and comfortable in design. It provides a simple means for the underwater swimmer to carry limpet mines. It also increases the number of limpets that can be carried by a swimmer.

5. PERSONNEL

- (a) It is believed by the writers that personnel of the Mezzi d'Assalto group could be used to a great advantage by the Maritime Unit of the Southeast Asia Command. These men are highly trained experts in the use of the special equipment reported herein.
- (b) The amount of personnel which would be of value to S.E.A.C. is dependent upon the political agreement which can be reached with the Italian Government. It is believed that if the personnel procured can be used as operators, the number procured should include at least the basic group recommended by Captain Forza. If the political agreement made with the Italian Government will only allow the men procured to act as instructors, it is believed that one or two instructors for each type of weapon plus an equipment maintenance group would suffice.

- (c) The type of personnel which would be of value to S.E.A.C. is partially dependent upon the type of equipment that can be procured from sources other than the Mezzi d'Assalto group. If "Chariots" are procurable from the British, it would be advisable to procure a larger number of chariot operators.
- (d) The entire personnel of the Mezzi d'Assalto group are willing and anxious to go to S.E.A.C. in the employment of O.S.S. These men are willing to go to S.E.A.C. as either instructional or operational personnel. It is believed by the writers that these men would have to be given some status in the American Army or Navy if authorized to duty in S.E.A.C. as operational personnel. This technicality is due to the fact that Italy is not at war with Japan and cannot permit members of the Italian armed forces to actively engage in hostilities against Japan while in Italian uniform.

V. RECOMMENDATIONS:

The following recommendations are formed from the foregoing conclusions. It is recommended that:

M.T.S.M.

1. O.S.S. acquire all the MTSM's for S.E.A.C.
2. O.S.S. acquire 15 each special torpedoes for use by the MTSM's.

- ~~CONFIDENTIAL~~
3. All motors from the MTSM's be removed for use in the MTM's.
  4. Motors of American manufacture be installed in all MTSM's.

M.T.M.

5. O.S.S. acquire all the MTM's for S.E.A.C.
6. All MTSM motors be installed in the MTM's requiring new motors.
7. Proper materials (such as mahogany wood, linen and proper accessories) be made available for repairing the damaged hulls of MTM's.
8. The Maritime Unit and Research and Development, Technical Branch, in Washington, investigate the possibility of adapting some American boats for use as explosive motor boats in the future.

CHARIOT

9. O.S.S. acquire 2 each complete usable "Chariots" for S.E.A.C. from the Mezzi d'Assalto Group.
10. Inquiries be made to ascertain if the British Royal Navy has any "Chariots" ("Pig Boats") available.
11. Inquiries be made to ascertain if the British Royal Navy has the manufacturing facilities to produce some "Chariots."
12. O.S.S. procure 3 each complete usable "Chariots" for S.E.A.C. from the British Royal Navy.

"KANGAROO"

13. O.S.S. acquire 1 each "Kangaroo" for S.E.A.C.



~~CONFIDENTIAL~~

GAMMA EQUIPMENT

14. O.S.S. acquire all available Italian Gamma equipment for S.E.A.C.
15. O.S.S., Washington, D.C., procure the manufacture in the United States of the Mae West or pneumatic type limpet for use in S.E.A.C.
16. O.S.S., Washington, D.C., procure the manufacture in the United States of the silent pneumatic cable and net cutter for use in S.E.A.C. (This piece of equipment should have "top priority.")
17. The head net for camouflage purposes be made standard equipment with the Maritime Unit underwater swimmers.
18. The limpeteers canvas vest be made standard equipment with the Maritime<sup>©</sup> Unit underwater swimmers.
19. O.S.S., Washington, D.C., procure the manufacture of the Matarrassino in the United States for use in S.E.A.C.
20. Inquiries be made to ascertain if the British Navy has any models of the Matarrassino available.
21. O.S.S. conduct limited tests to determine the efficiency of the Italian underwater compass in comparison to the American design.

PERSONNEL

22. The following amounts of qualified personnel be sent to S.E.A.C. if the agreement made with the Italian Government will only permit personnel to act in an instructional capacity:

~~TOP SECRET~~  
2 each MFSM--MM specialists

1 each "Chariot" specialist (2 each specialists would be necessary if British "Chariots" are available)

2 each Gamma specialists

1 each underwater technician if no British "Chariots" are available. (4 each such technicians would be required if British "Chariots" are available.)

2 each surface technicians

23. The following amount of qualified personnel be sent to S.E.A.C. if the political agreement with the Italian Government permits Italian personnel to participate in operations:

5 each MFSM--MM operators

2 each "Chariot" operators (if no British "Chariots" are available)

5 each "Chariot" operators (if British "Chariots" can be made available)

10 each Gamma men

1 each underwater technician (if no British "Chariots" are available)

4 each underwater technicians (if British "Chariots" can be made available)

2 each surface technicians

1 each experienced operations officer.

POLITICAL ACTION

24. O.S.S. Contact the Italian Ministry of Marines to ascertain if:

- (a) the entire Mezzi d'Assalto group can be procured for instructional duties in S.E.A.C.

- (b) a part of the Mezzi d'Assalto group can be procured for instructional duties in S.E.A.C.
- (c) the entire Mezzi d'Assalto group can be procured for operational duties in S.E.A.C. if given some special American status.
- (d) a part of the Mezzi d'Assalto group can be procured for operational duties in S.E.A.C. if given some special American status.

This report is submitted jointly by:

*Kelly O'Neall*

Kelly O'Neall  
Ensign, U.S.N.R.  
Maritime Unit

*Louis P. Zelenka*

Louis P. Zelenka  
1st Lieutenant, Corps of Engineers  
Technical Branch  
Research and Development

~~SECRET CONTROL~~

PARAPHRASE

MTSM--MTM

1. It is believed highly desirable that 5 each MTSM boats and 11 each MTM boats be procured immediately by the Office of Strategic Services from the Mezzi d'Assalto Group. These boats could be used for operational and training duty in Southeast Asia.

2. These boats will require certain repairs which have been discussed and enumerated in the Conclusions of this report. It is the opinion of the writers that these repairs would take a considerable period of time if the necessary motor parts had to be manufactured in the United States. Therefore, it is suggested that all motors presently used in the MTSM boats be removed and installed in the MTM boats. The Chief Engineer of the Mezzi d'Assalto group has stated that by installing all MTSM motors in MTM boats he would be able to put 11 each MTM boats in good operational condition. He further stated that he would be able to have available at least 2 spare engines for future use in the MTM boats. He estimated that his men could complete this work within 3 days.

3. It is believed highly desirable to replace present MTSM motors with American marine engines. This will be necessary if the engines now in the MTSM boats are removed for use in the MTM's. The exact make of American engine which would

~~SECRET CONTROL~~

be suitable for use in the MTSM's can not be stated at this time. Lieutenant Zelenka, of Research and Development, is of the opinion that several types of 90 to 95 horsepower inboard engines would be satisfactory.

4. The writers consider it highly advisable to make available materials for repairing the hulls of the MTM boats which require such repairs. These repairs do not require the manufacture of any new parts or the procuring of any priority materials. The Chief Engineer of the Mezzi d' Assalto group has stated that with the proper materials his men could complete the necessary hull repair work within 7 days.

5. It is believed advisable that the work of transferring engines from MTSM boats to MTM boats be done by Mezzi d'Assalto personnel at San Vito Bay. It is also suggested that the hull repair work be done at San Vito. The work of installing American engines in the MTSM boats should be done by American personnel. This work could be done either in Italy or in Southeast Asia. The Mezzi d'Assalto group has the facilities and is ready to begin repair work after the MTSM and MTM boats are procured by the Office of Strategic Services from the Italian Government and after hull repair materials are furnished by O.S.S.

6. It is believed advisable that Research and Development, Washington, D.C., in conjunction with the Maritime Unit, Washington, D.C., be given a directive to develop an American explosive motor boat. These boats will be necessary if the

Italian MTM's are operationally expended.

"CHARIOTS"

7. It is considered highly desirable that 2 each "Chariots" be procured immediately by the Office of Strategic Services from the Mezzi d'Assalto Group for operational and training duty in S.E.A.C.

8. These 2 "Chariots" would not be an adequate number for any very extensive "Chariot" operations. It is therefore believed advisable for O.S.S. to procure at least 3 each additional "Chariots" from the British. Inasmuch as the British manufactured the 2 "Chariots" which are presently used by the Mezzi d'Assalto group, it is known that the British either have a supply of "Chariots" on hand or have the facilities for their further manufacture.

9. In the event that additional British made "Chariots" can not be procured through reverse lend-lease, it is not recommended that O.S.S. procure the manufacture of additional "Chariots" in the United States. It is anticipated that such production would require too long a period of time to be worthwhile.

GAMMA EQUIPMENT

10. It is the opinion of the writers that the Maritime Unit, Washington, D.C., should ascertain if the American underwater swimmers of the Maritime Unit could use the following items of equipment:

silent pneumatic cable and net cutter

~~SECRET CONTROL~~

limpet, Mae West type

limpeteer's vest

camouflage head net

Matarrassino

The writers believe that O.S.S., at the present time, has silent pneumatic cable and net cutter nor any comparable item equipment. This addition to the equipment of American underwater swimmers would greatly increase their efficiency. It is opinion of the writers that the Maritime Unit, Washington, should procure the manufacture in the United States of the silent pneumatic net and cable cutter. Lieut. Zelenka of Research Development believes that the Italian cable and net cutter could be improved by constructing the two canisters of aluminum some lighter alloy. In the event that O.S.S. procures operational Gamma personnel from the Mezzi d'Assalto Group, several silent pneumatic cable cutters would be needed by this Group.

The pneumatic or Mae West limpet is particularly desirable use in S.E.A.C. because it can be used to attack concrete and wooden targets. It is the belief of the writers that the Maritime Unit, O.S.S. has no comparable limpet at present. It is suitable for attacking concrete and wooden targets such as are found among river and coastwise traffic in S.E.A.C. It is completely silent in operation. The writers suggest that some American type limpet might easily be adapted to use the Mae West limpet principle of suction. It is believed that the Maritime

- 4 -

~~SECRET CONTROL~~

~~SECRET CONTROL~~

Unit in cooperation with the Research and Development Branch should either find an American limpet which is completely silent in operation and adaptable for use against concrete and wooden targets, or should procure the manufacture of the Mae West type limpet which is silent and has already been operationally successful against concrete and wooden targets.

In the event that operational Gamma personnel are procured by O.S.S. from the Mezzi d'Assalto Group, a supply of Mae West type limpets would be required.

It is suggested that the Maritime Unit, Washington, D.C., ascertain if the American underwater swimmers might not benefit by adopting the limpeteers vest. This vest has the advantage of permitting an operator to comfortably carry from 5 to 7 limpets and still have his feet, legs, hands and arms free. It is believed that an ordinary large size vest could be fitted with loops for attaching limpets and other gear. The Gamma unit of the Mezzi d'Assalto Group has an adequate supply of limpeteers vests for their own use.

It is suggested that the Maritime Unit, Washington, D.C., ascertain if American underwater swimmers would benefit by adoption of the camouflage head net. This net has the advantage of permitting a swimmer to come to the surface without being conspicuous. With the net in position, a swimmer with his head partially above the surface of the water looks like floating debris or seaweed. Several types of camouflage netting already

~~SECRET CONTROL~~



~~SECRET CONTROL~~

already available in the United States would make satisfactory head netting for underwater swimmers. Lieut. Zelenka believes the head net might be improved and made lighter in weight if it was made of nylon. He does not recommend a specially manufactured head net if some available camouflage netting is suitable.

It is suggested that the Maritime Unit, Washington, D.C., ascertain if the American underwater swimmers might not benefit from the adoption of the Matarrassino as standard equipment. The Matarrassino has greatly increased the range of the Italian Gamma men. It has also provided a small float which can be used to carry additional Gamma equipment. The writers believe that the O.G. and S.O. branches of O.S.S. might also be interested in adopting the Matarrassino. This float is light in weight, compact in size when deflated, and suitable for ferrying one man with equipment across an inland water hazard. The writers believe that the British have already manufactured copies of the Matarrassino. It is suggested that the Maritime Unit, O.S.S., procure a supply of Matarrassino floats on reverse lend-lease. It is further suggested that the Maritime Unit discuss the possible uses of the Matarrassino with the O.G. and S.O. Branches of O.S.S.

PERSONNEL

11. The amount of personnel that O.S.S. should procure from the Mezzi d'Assalto group is dependent upon the type of duty the Italian Government will authorize for this personnel. If

~~SECRET CONTROL~~

~~SECRET CONTROL~~

the Italian Government will approve only instructional duties for this personnel, the writers believe a staff of 5 instructors and 3 technicians would be adequate.

12. The writers believe that every effort should be made to obtain the permission of the Italian Government to use Mezzi d'Assalto personnel in S.E.A.C. for operational duties.\*

Inasmuch as the Italian Government is not at war with Japan, Mezzi d'Assalto personnel could not perform operational duties as members of the Italian armed forces. It is believed that O.S.S. could give this personnel some special American status that would permit them to operate under the cover of the United States armed forces. The attitude of the Italian Government toward such a suggestion is not known by the writers.

.....

\*The special weapons reported herein require rather lengthy and intensive training periods. The specific period of training used by the Mezzi d'Assalto Group for each weapon is: MISM--MTM, 2 to 3 months; "Chariot," 6 to 8 months; and Gamma, 6 months. These training periods presume that the trainee has certain special qualifications prior to the beginning of his training. For example: the MISM--MTM trainees are expected to be excellent seamen, the "Chariot" operators are required to have some knowledge of submarine principles, and the Gamma trainees are required to be excellent swimmers. The writers believe that it would require longer training periods to teach natives in S.E.A.C.

~~SECRET CONTROL~~

to use this special equipment. The training of native Gamma operators is a possible exception. The personnel of the Mezzi d'Assalto group is already highly trained in the use of the weapons covered in this report, and a large number of them have had successful operational experience with these weapons. The men of the Mezzi d'Assalto group are eager to be procured by O.S.S. for operational duty against Japan. They are willing to be recruited for this duty under any agreement which is satisfactory to the Italian Ministry of Marines.

OPERATIONAL ACTIVITY OF THE 10TH M.A.S. FLOTILLA  
DURING THE PERIOD 10 JUNE TO 9 SEPTEMBER 1943

No. Date	Location	Outcome	Means Used	Operators	Losses
1 Aug. 1940	Alexandria	Negative	Sub Iride 4 S.L.C.	5 Officers (S.C.) 3 Noncoms (S.C.) and sailors	Sub Iride sunk. Dead: the whole crew except 12 persons
2 Sep. 1940	Gibraltar	Negative	Sub Scire 3 S.L.C.	4 Officers (S.C.) 4 Noncoms (S.C.) and sailors	
3 Sep. 1940	Alexandria	Negative	Sub Gondar 3 S.L.C.	6 Officers	Sub Gondar sunk. All aboard taken prisoners.
4 Oct. 1940	Gibraltar	Negative 1 Operator (TV BIRIN- DELLI) enters the port but because of mechanical failure is forced to abandon all attempts at 70 meters from the ship Barbham	Sub Scire 3 S.L.C.	4 Officers (S.C.) 4 Noncoms (S.C.) and sailors	2 prisoners

~~SECRET CONTROL~~

No.	Date	Location	Outcome	Means Used	Operators	Losses
5	Mar. 1941	Suda	1 cruiser (York) sunk, 3 steamships sunk.	6 small explosive boats transported by the torpedo destroyers Crisp and Sella	2 Officers 4 Noncoms (S.C.) and sailors	All operators taken prisoner.
6	Apr. 1941	Porto Edda	Negative	2 M.T.S.M.'s	3 Officers 1 Noncom	
7	May 1941	Gibraltar	Negative	Sub Scirè 3 S.L.C.'s	4 Officers (S.C.) 4 Noncoms (S.C.) and sailors	
8	July 1941	Malta	Negative	8 explosive boats 2 S.L.C.'s 2 M.A.S. SS Diana	14 Officers (S.C.) 11 Noncoms (S.C.) and sailors	10 dead 1 wounded and captured 8 captured
9	Sep. 1941	Gibraltar	3 ships sunk (1 inside the port, 2 at the entrance)	Sub Scirè 3 S.L.C.'s	5 Officers (S.C.) 4 Noncoms (S.C.) and sailors	Returned safely
10	Dec. 1941	Alexandria	2 battleships sunk (Queen Elizabeth, Valiant) 1 tanker	Sub Scirè 3 S.L.C.'s	5 Officers (S.C.) 5 Noncoms (S.C.) and sailors	6 prisoners
11	May Sep. 1941	Black Sea	Blockade of Sevastopol, 1 munitions transport sunk, 3 armed boats destroyed, 40 prisoners taken	Expedition by truck. 5 explosive boats, 13 trucks	9 Officers (S.C.) 11 Noncoms (S.C.) and sailors	Killed: 1 Non-com Seriously Wounded: 1 sailor

No.	Date	Location	Outcome	Means Used	Operators	Losses
12	May 1942	Malta	Landed Borga Pisani. Explored small inlet with small boat	2 torpedo boats	3 Officers (S.C.) and sailors	1 prisoner 1 shot
13	May 1942	Alexandria	Negative	Sub Ambra 3 S.L.C.'s	4 Officers (S.C.) and sailors	6 prisoners
14	Jul. 1942	Gibraltar	1 boat sunk; 1 boat damaged	Gamma	2 Officers and Noncoms (S.C.)	
15	Jul. 1942	Eastern Mediterranean	Negative for lack of objectives	Fishing boat "Cefalov"; 2 small torpedo boats	2 Officers and Noncoms	
16	July Aug. 1942	Haifa	Negative	Sub Scirè 10 gamma men	1 Officer and 10 Noncoms (S.C.) and sailors	Sub Scirè sunk All lost
17	Aug. Sep. 1942	Egypt Libya Tunisia	Torpedoed 1 English torpedo destroyer, in type Jerwis, in front of El Daba	Motorboat Costanza, fishing boat Sogliola, 6 explosive boats; 4 torpedo boats; first carried on the motor-fishing boats, then by truck to the base near El Alamein	3 Officers and 9 Noncoms (S.C.) and sailors	

No.	Date	Location	Outcome	Means Used	Operators	Losses
18	Sep. 1942	Malta	Negative	2 M.T.S.M.'s	2 Officers (S.C.) 2 Noncoms (S.C.) and sailors	1 M.T.S.M. sunk 1 seriously wounded
19	Sep. 1942	Gibraltar	3 boats sunk	Gamma	1 Officer 3 Petty Officers	
20	Oct. 1942 Jul. 1943	Pantelleria Tunisia	Negative	Sent out on trucks and motor-fishing boats to attack Tunisian ports and defend the islands with M.T.S.M.'s and M.T.M.'s.	9 Officers 14 Noncoms (S.C.) and sailors	3 killed Fishing boat Cefalo sunk and later salvaged
21	Oct. 1942 Jul. 1943	Lampedusa	Negative	(Same as above)	1 Officer 4 Noncoms	
22	Dec. 1942	Gibraltar	Negative	3 S.I.C.'s	2 Officers (S.C.) 3 Noncoms (S.C.) and sailors	3 killed 3 prisoners
23	Dec. 1942	Algiers	1 cruiser and 4 steamboats sunk	Sub Ambra 3 S.I.C.'s 10 Gamma	5 Officers 13 Noncoms (S.C.) and sailors	
24	Dec. 1942	Malta	Negative	2 M.T.S.M.'s and Gamma operators	4 Officers 2 Petty Officers	
25	Mar. 1943	Malta	Negative	2 M.T.S.M.'s and Gamma operators	4 Officers 1 Petty Officer	

No.	Date	Location	Outcome	Means Used	Operators	Losses
26	Mar. 1943 Sep. 1943	Sardinia	Negative	Expedition by motor-fishing boats for defense of the islands by M.T.S.M.'s and M.T.M.'s	4 Officers (S.C.) 19 Noncoms and sailors	Fishing boat Sogliola sunk, 5 persons killed, 5 persons missing, while changing boats in Sardinia as a result of the sinking of the boat Tripoli
27	May 1943	Gibraltar	3 boats sunk	Ship Olterra 3 S.I.C.'s	3 Officers (S.C.) 3 Noncoms and sailors	
28	May 1943 Aug. 1943	Sicily Calabria Campania	Negative	6 M.T.S.M.'s 4 M.T.M.'s	7 Officers 12 Noncoms (S.C.) and sailors	1 dead; 3 wounded by machine gunning
29	July 1943	Zone XXX	3 Merchant ships sunk	Gamma	1 Officer	
30	Aug. 1943	Gibraltar	3 boats sunk	Ship Olterra 3 S.I.C.'s	3 Officers 3 Noncoms (S.C.)	1 prisoner
31	Aug. 1943	Gulf of Spezia	1 Sub sunk	1 M.T.S.M.	2 Officers	

~~CONFIDENTIAL~~



~~SECRET CONTROL~~

~~SECRET CONTROL~~

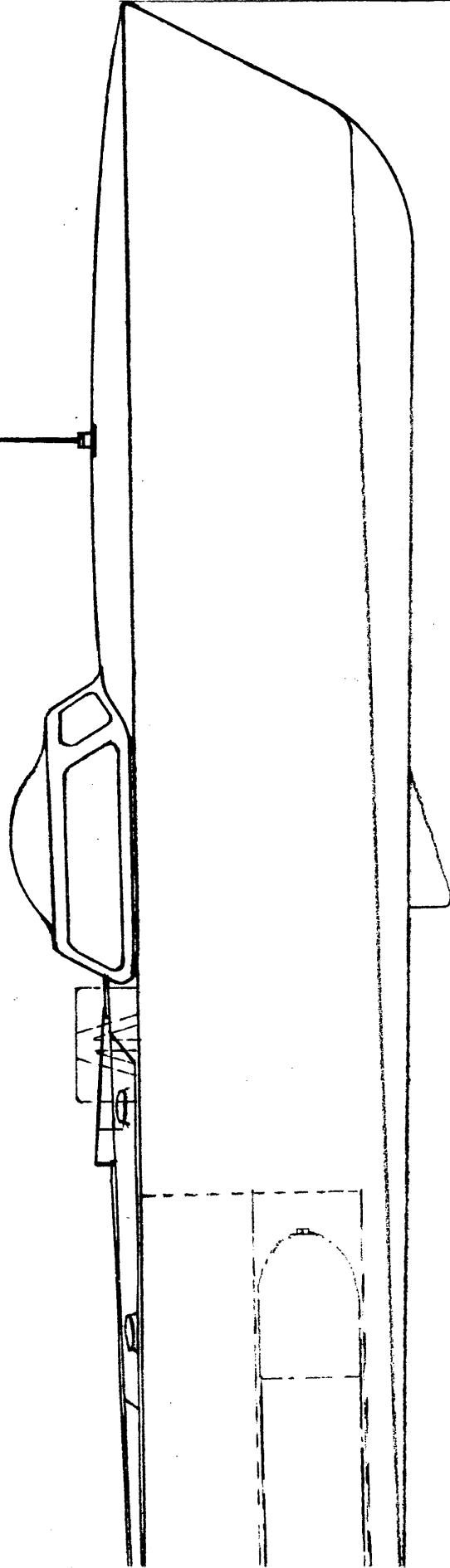

25' 7"

ASSAULT BOAT M.T.S.M.

~~SECRET CONTROL~~

~~SECRET CONTROL~~

~~SECRET CONTROL~~

~~SECRET CONTROL~~

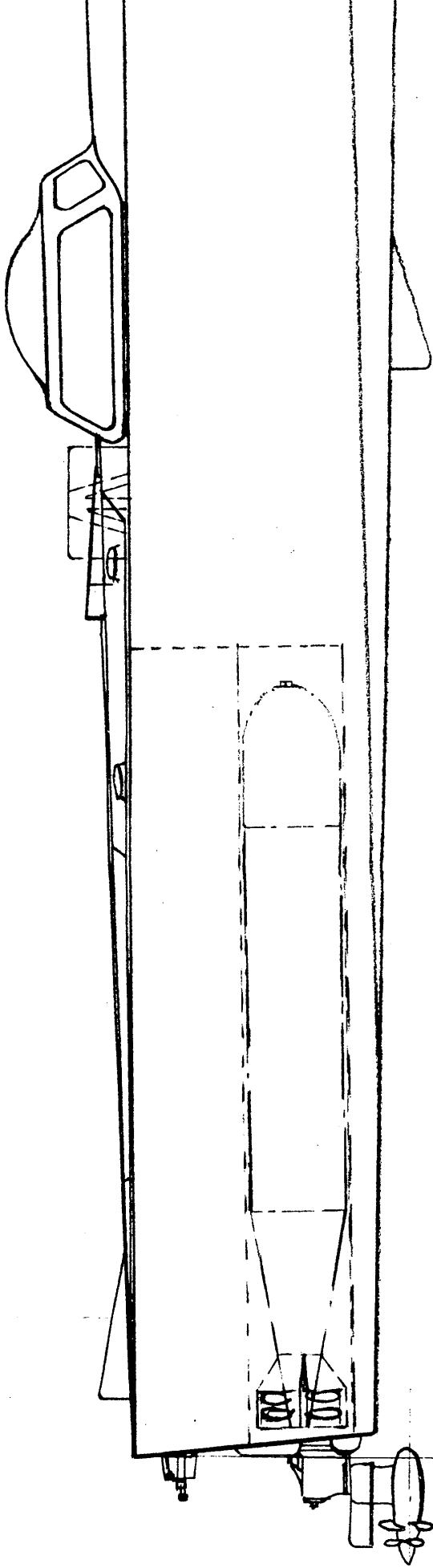

25' 7"

~~SECRET CONTROL~~

~~SECRET CONTROL~~

ASSAULT

~~SECRET CONTROL~~  
INVERTOR

~~SECRET CONTROL~~

MOTOR

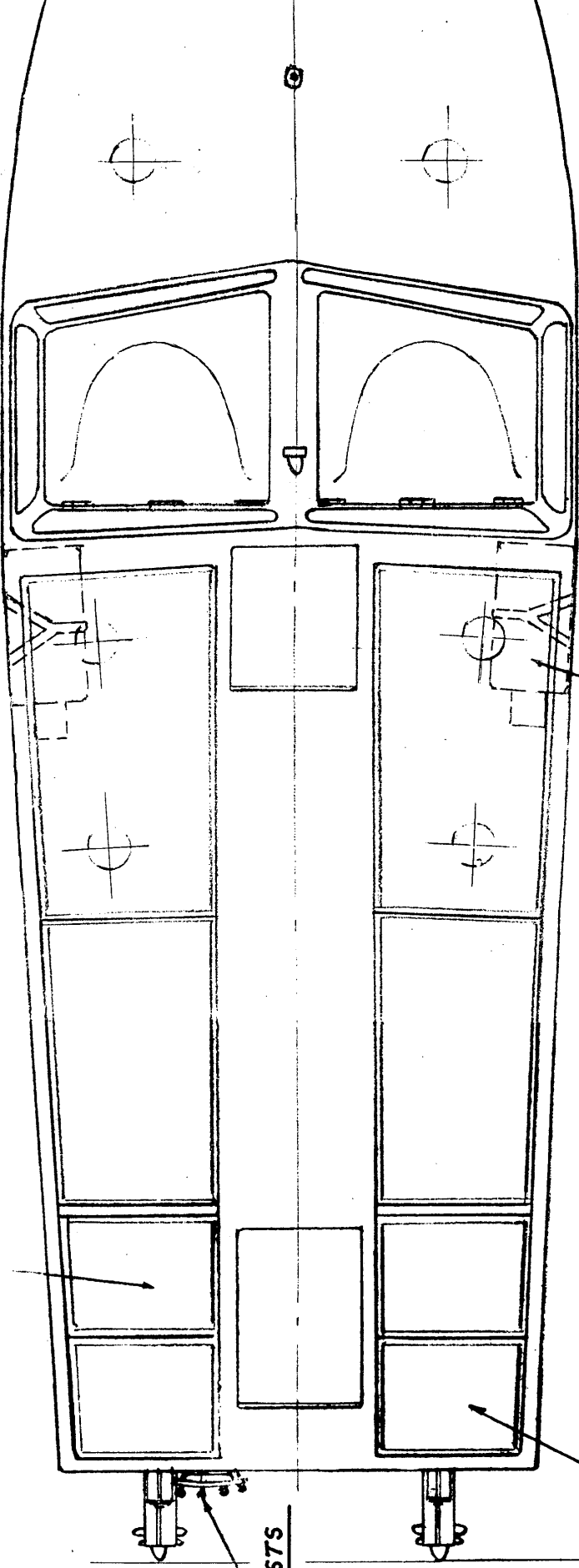

EXHAUSTS

PROPPELLER UPLIFT

T. G. Bombs

ASSAULT BOAT

27' 5.5"

~~SECRET CONTROL~~

~~SECRET CONTROL~~

~~SECRET CONTROL~~  
INVERTOR

MOTOR

~~SECRET CONTROL~~

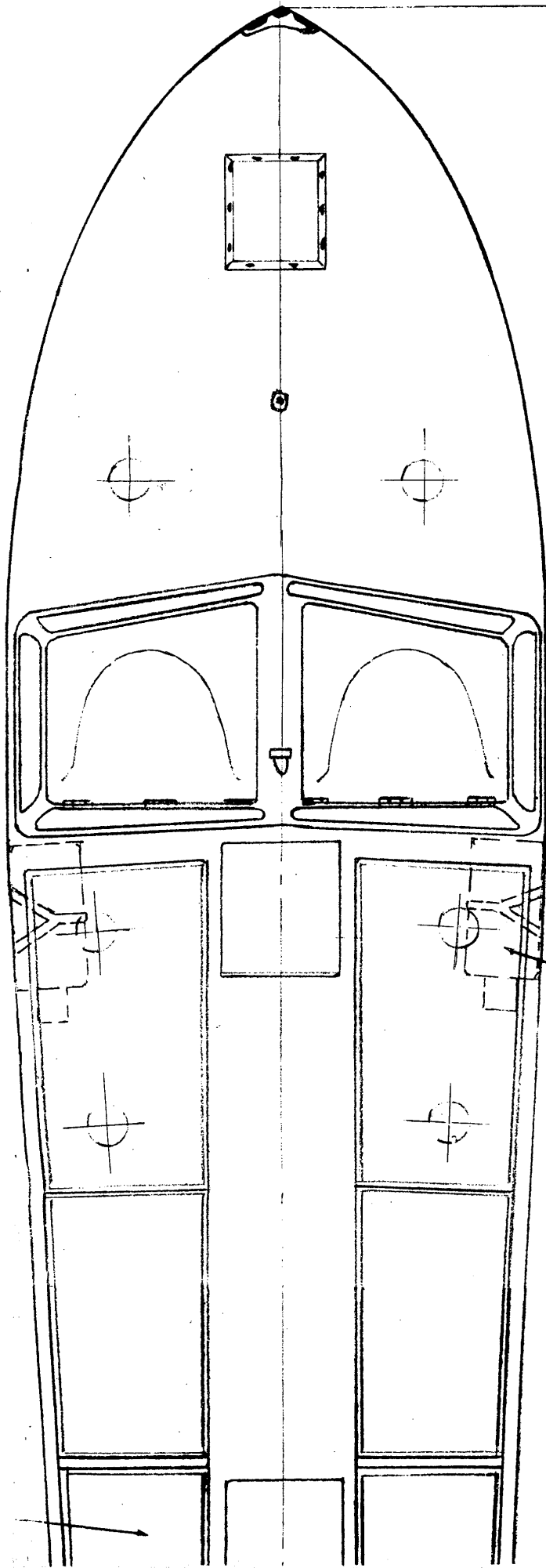

UPLIFT

T. G. Bombs

ASSAULT BOAT M.T.S.M.

27' 5.5"

~~SECRET CONTROL~~

~~SECRET CONTROL~~

~~SECRET CONTROL~~

~~SECRET CONTROL~~

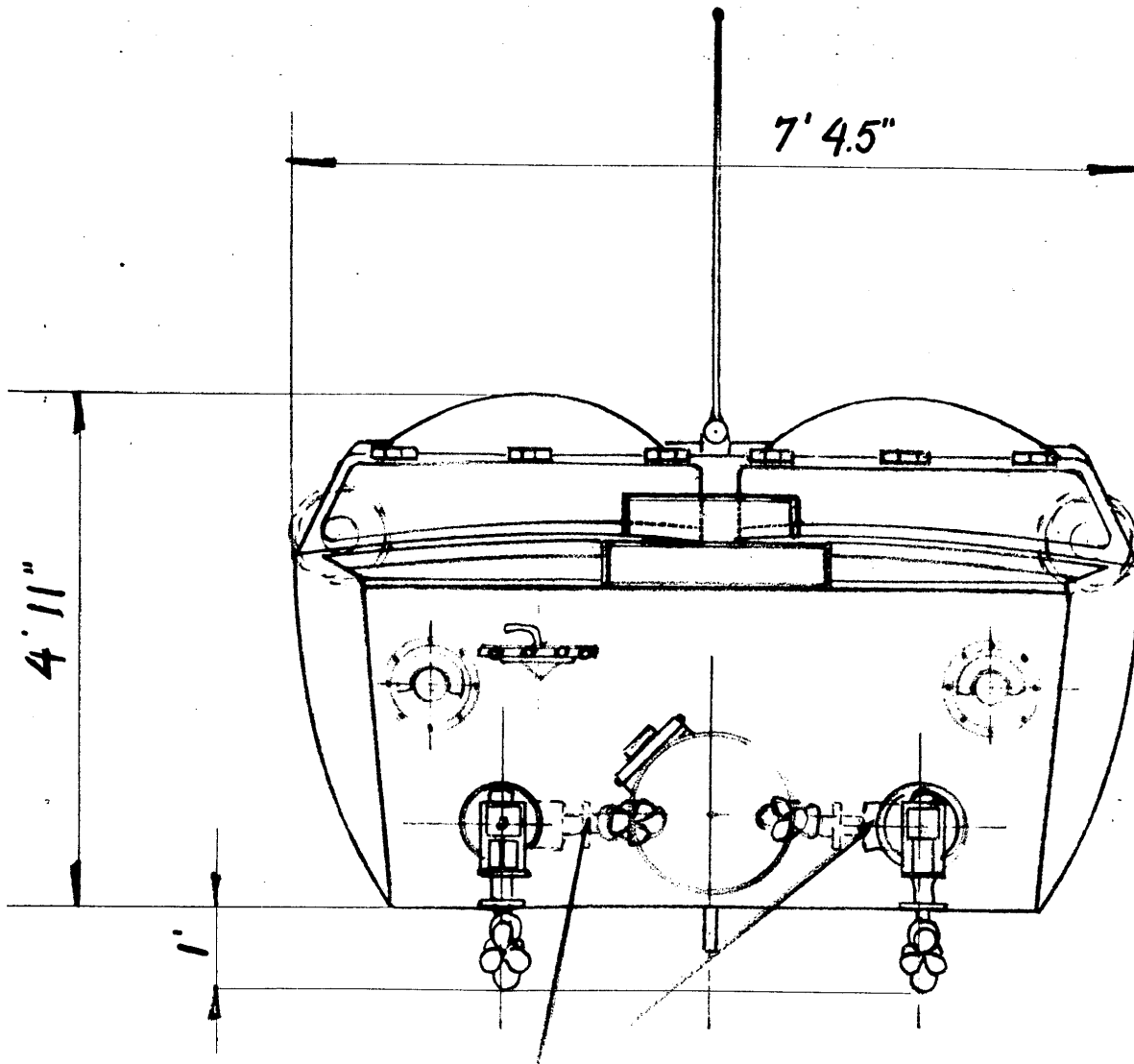

CLEARING POSITION

ASSAULT BOAT M.T.S.M.

~~SECRET CONTROL~~

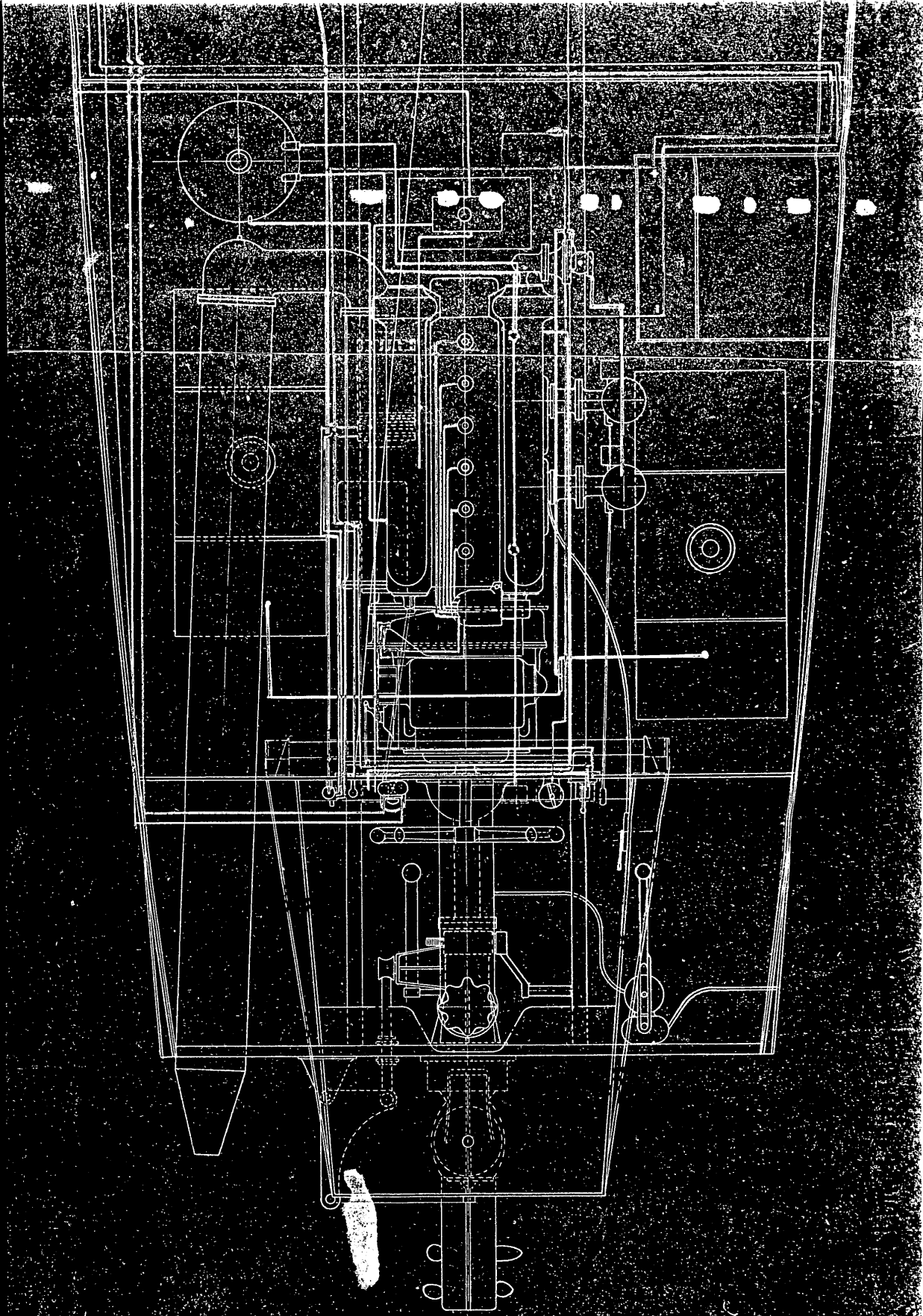

elio  
H<sub>2</sub>O  
vapore  
benzina  
grasso

SECRET CONTROL

SECRET CONTROL

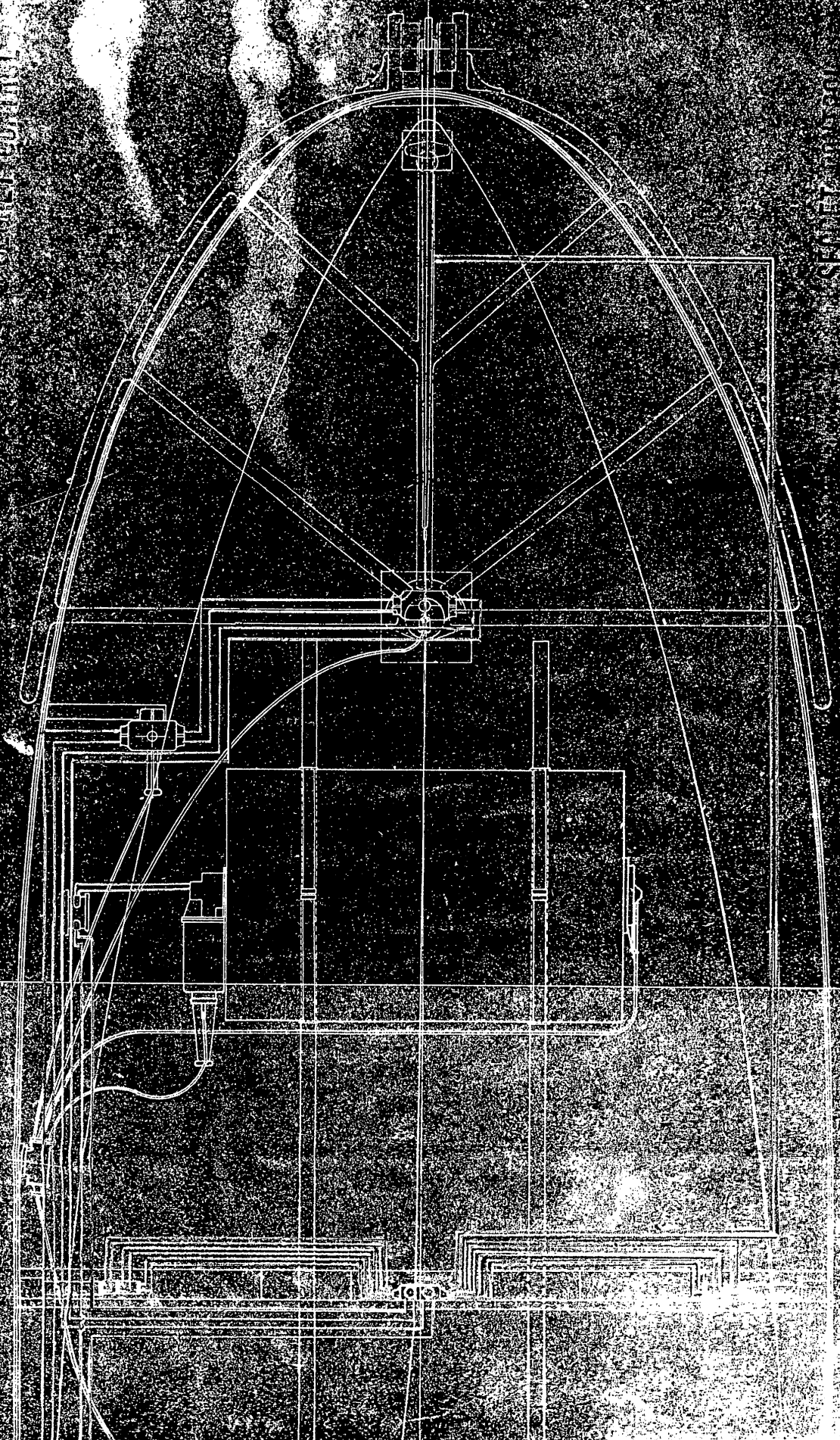

SECRET CONTROL

SECRET CONTROL

THE

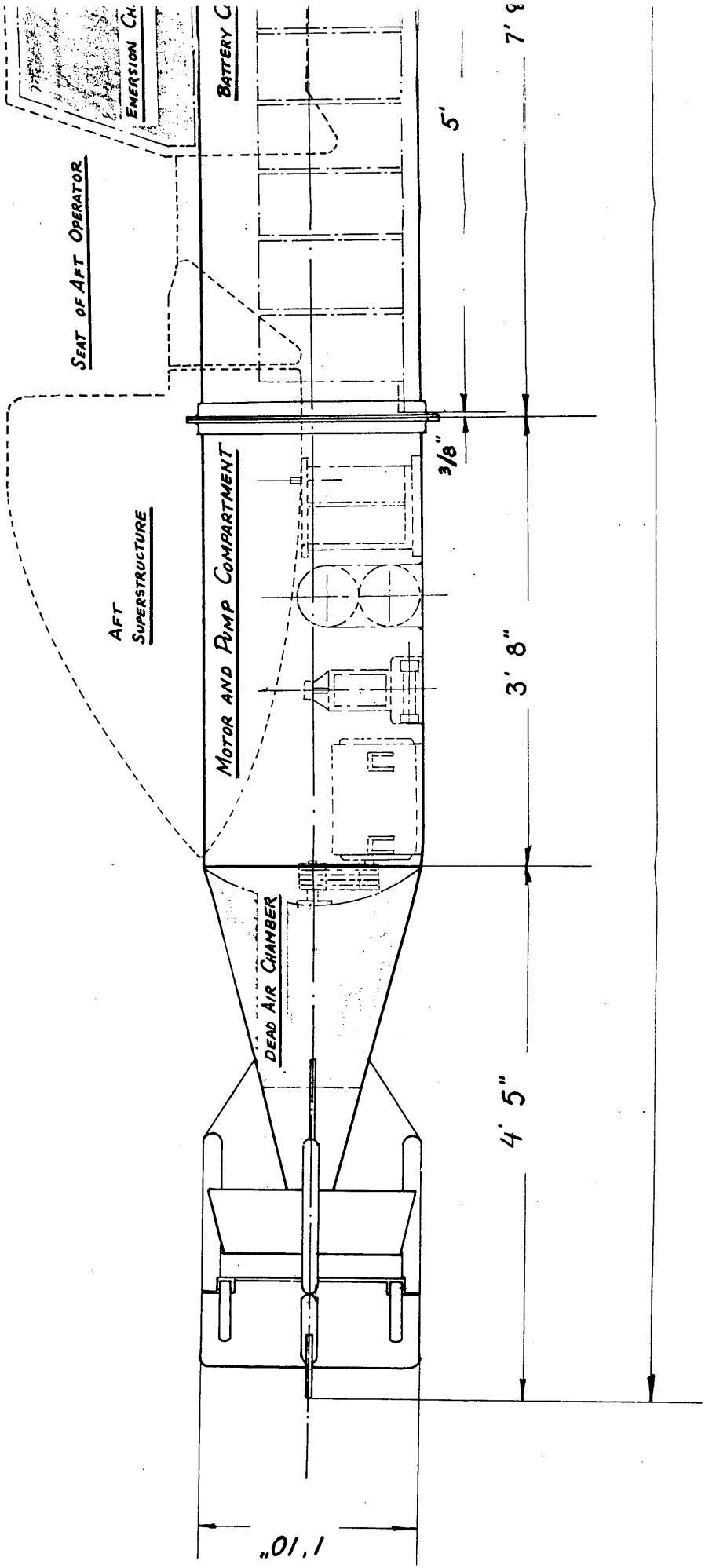

SEAT OF AFT OPERATOR

AFT SUPERSTRUCTURE

MOTOR AND PUMP COMPARTMENT

DEAD AIR CHAMBER

BATTERY C

.01,1

3/8"

5'

4' 5"

3' 8"

7' 8"



# "HARIOT" S.L.C. - (3)

SCALE 1 - 10

SEAT OF FORWARD OPERATOR

FORWARD  
SUPERSTRUCTURE

PARTMENT

DEAD AIR CHAMBER

WAR HEAD

3' 11"

0.1

6' 6"

22' 3"

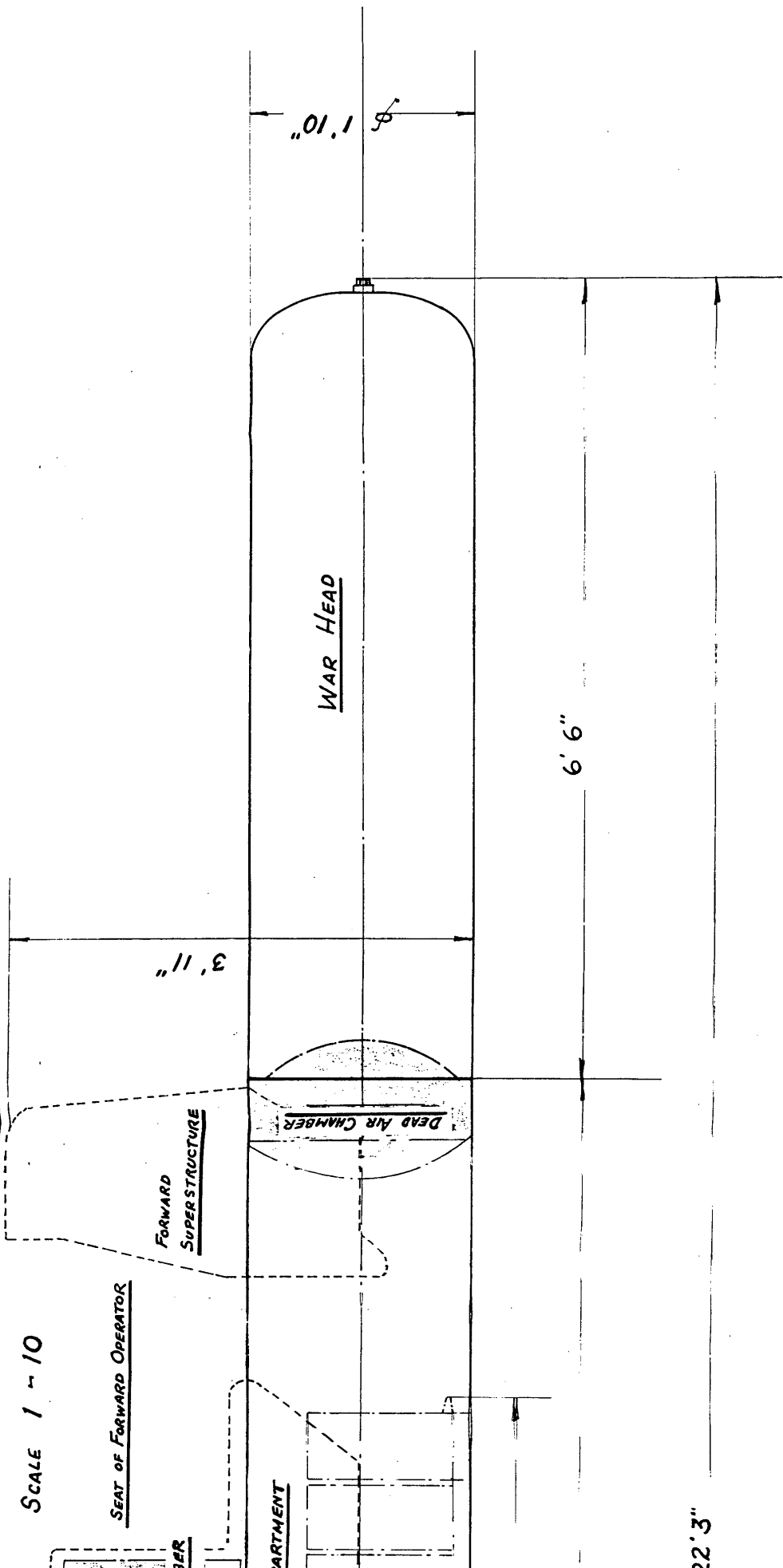

~~SECRET CONTROL~~

~~SECRET CONTROL~~

# "NEW CHARLI"

1" SCALE

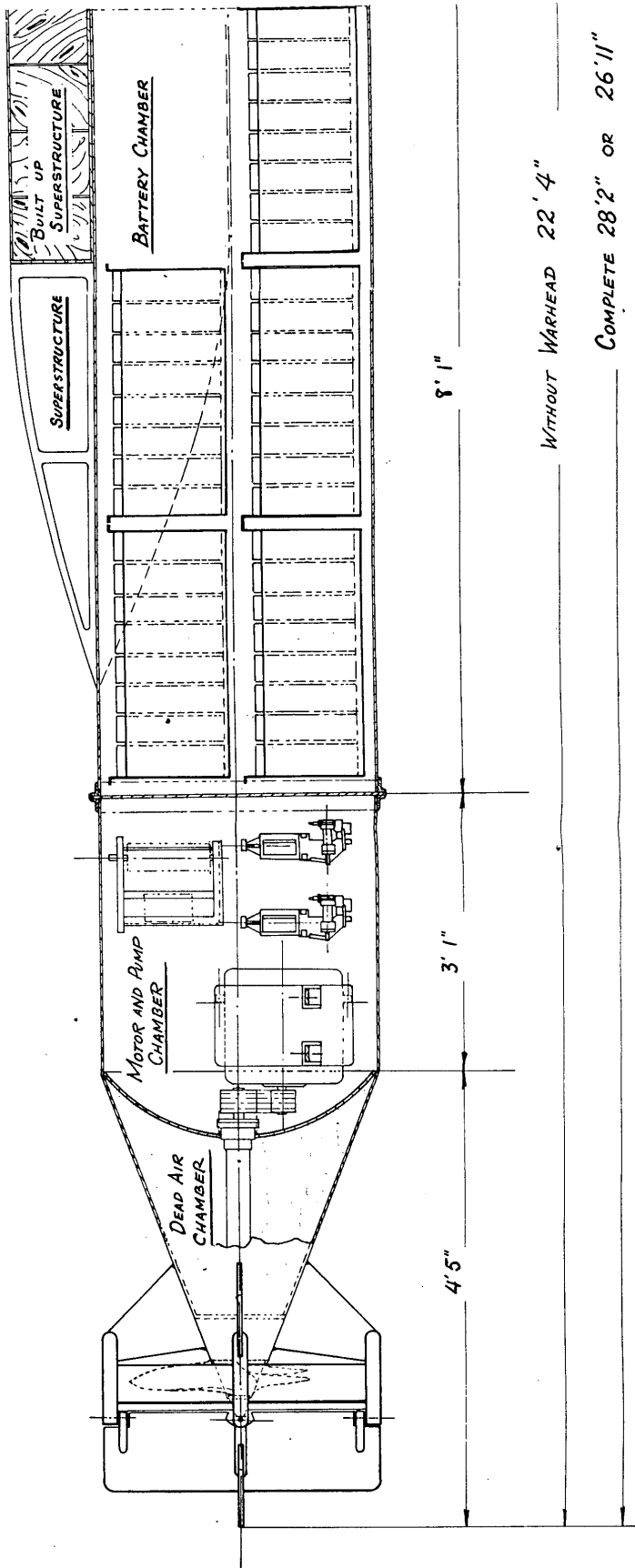

~~SECRET CONTROL~~

~~SECRET CONTROL~~

~~SECRET CONTROL~~

~~SECRET CONTROL~~

OT" S. B. M. ~ (7)

1-10 -

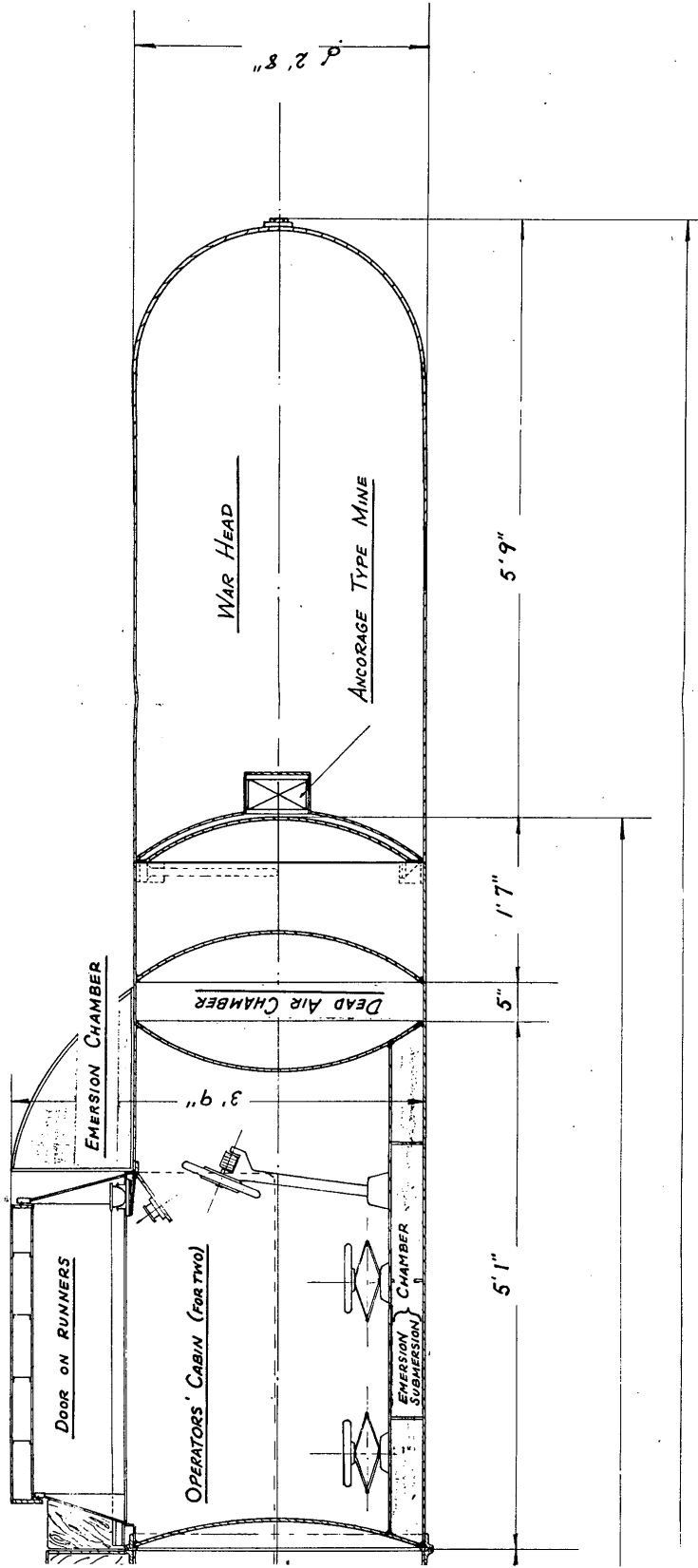

~~SECRET CONTROL~~

~~SECRET CONTROL~~

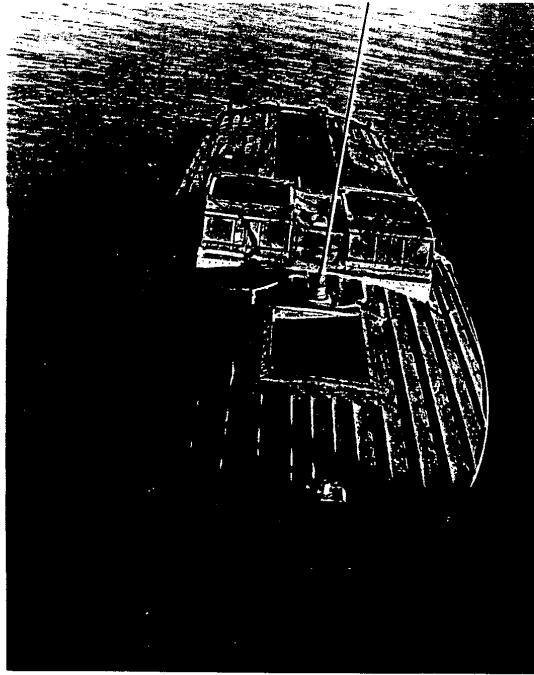

PHOTOGRAPH NUMBER 1

This photograph gives a top front full view of the MTSM boat. The hatches have been removed for illustrative purposes. The forward hatch provides access to the hull and serves as a storage place for line and tackle. The radio antenna is aft of the forward hatch. In operation, the heads and shoulders of the two pilots would protrude from the hatches of the dual cockpit, which is located aft of the antenna. The torpedo tube, with hatch removed, is aft of the dual cockpit. The engine compartment hatches are the raised hatches on either side of the torpedo tube.



PHOTOGRAPH NUMBER 2

This photograph shows the dual cockpit of the MTSM. The wind breakers at the left of the photograph are toward the bow. The dual control steering gear is visible inside the cabin. The cabin hatches remain open when this boat is in operation and the heads and shoulders of the operators protrude above the hatches. The operators stand in order to get better visibility.

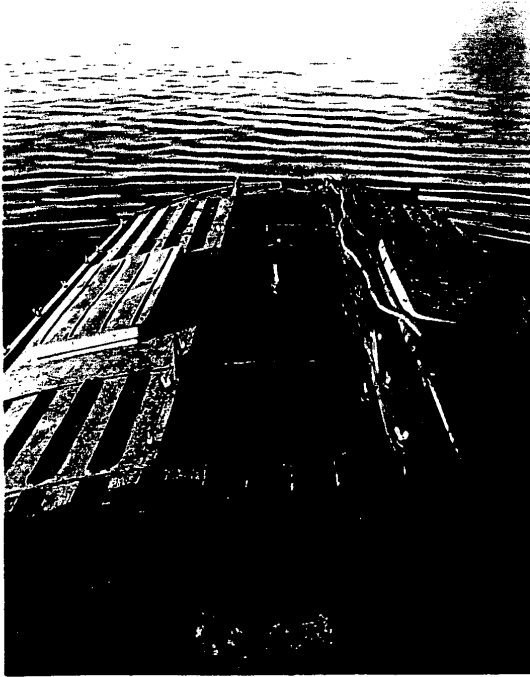

PHOTOGRAPH NUMBER 3

This photograph was taken from the cabin looking aft. The torpedo tube, with hatch removed, extends from 2 feet aft of the cabin to the stern. In the lower part of the photograph are the cockpit hatches, hinged back onto the deck. The hatches on either side of the forward end of the torpedo tube cover two of the three gasoline tanks. The raised hatches cover the motor compartments.



PHOTOGRAPH NUMBER 4

This photograph is a view of the torpedo tube looking forward. The pneumatic ram arms are just visible behind the cross beam at the forward end of the torpedo tube.

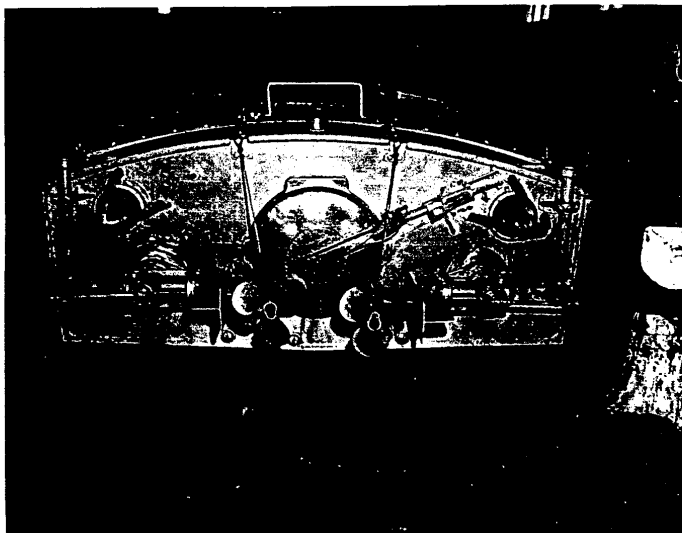

PHOTOGRAPH NUMBER 5

This photograph shows the stern of the MTSM. One exhaust transom is located just below deck level both at port and starboard. The propellers are in the fully retracted position. The torpedo tube release door is closed. Refer to Photograph Number 6 for a view of the MTSM with propellers fully extended and torpedo tube release door open.



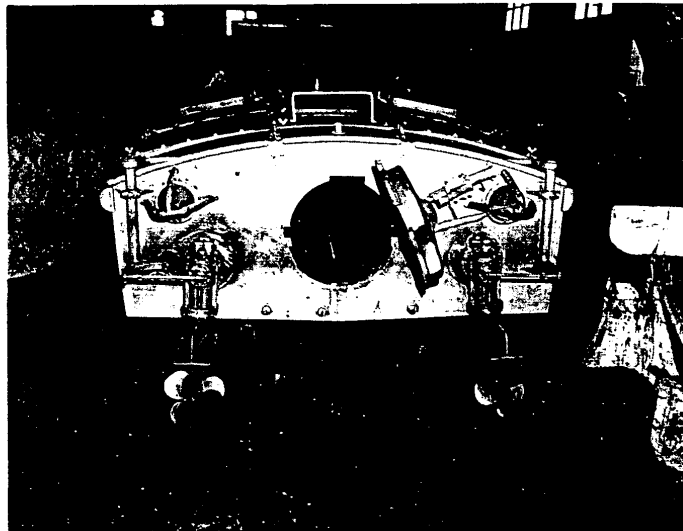

PHOTOGRAPH NUMBER 6

This photograph shows the stern of the MTSM with propellers fully extended and torpedo tube release door open. Refer to Photograph Number 5 for a view with propellers retracted and torpedo tube release door closed.

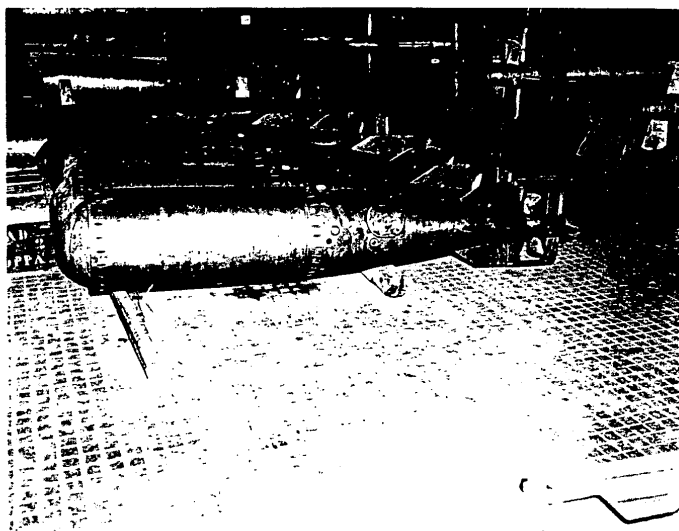

PHOTOGRAPH NUMBER 7

This photograph shows the special torpedo used by the MTSM. The war head is detached. This torpedo is 18 inches in diameter.

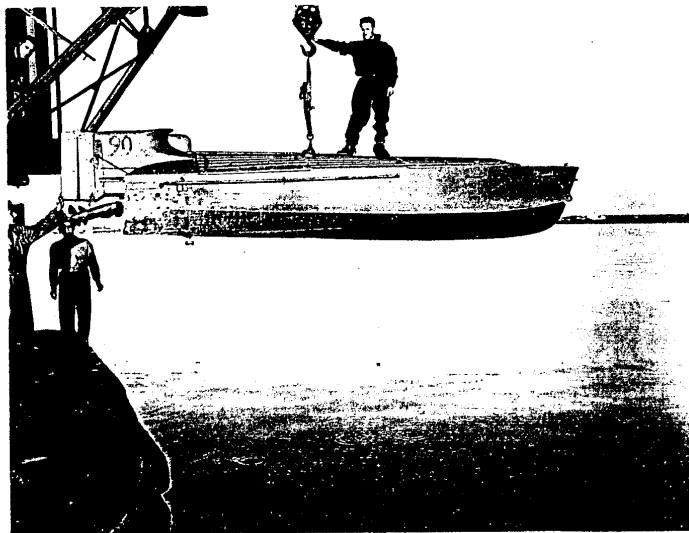

PHOTOGRAPH NUMBER 8

This photograph shows the MTM being hoisted out of the water. The pilot's cockpit is located at the after end. The propeller has been raised to an almost horizontal position. The pilot's escape raft is in carrying position aft of the pilot's cockpit. Note the hand grips just below the deck level. These grips are used to pull this boat over obstructions that rise above the surface of the water. Refer to Photograph Number 9 which shows the pilot's escape raft partially hinged out. Note the size of the craft in comparison with the pilot.

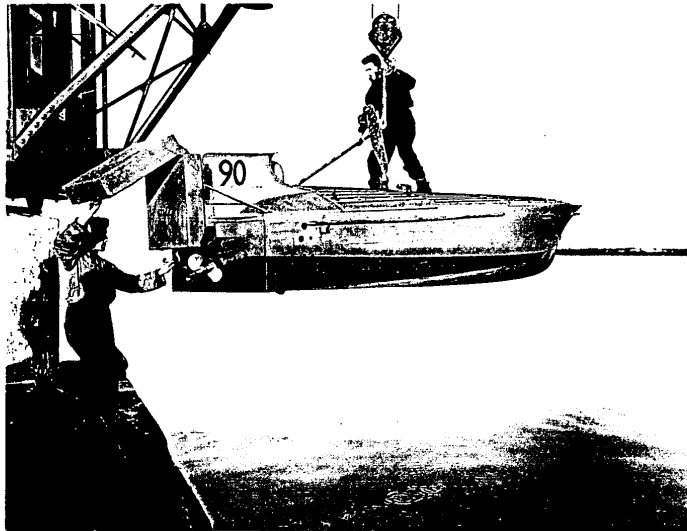

PHOTOGRAPH NUMBER 9

This photograph illustrates the pilot's escape raft partially hinged out from the MTM. After the pilot "freezes" the controls at a collision course toward the target, he releases this raft. When the raft is in the water, he swims to it and pulls himself out of the sea before the main charge detonates. Refer to Photograph Number 8 to see the escape raft in carrying position.

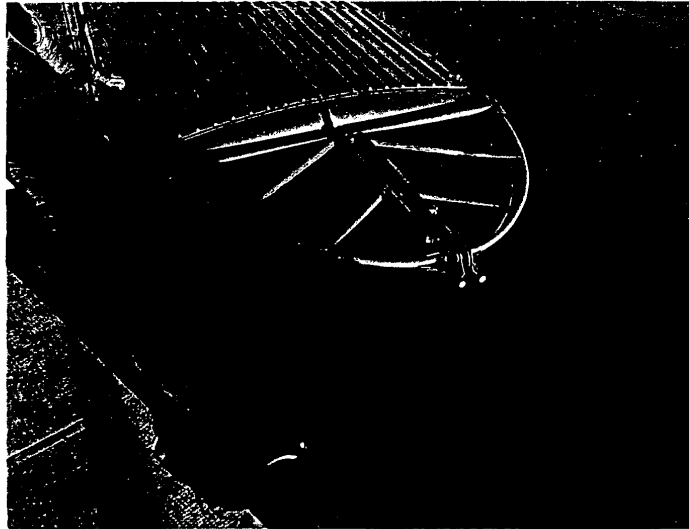

PHOTOGRAPH NUMBER 10

This photograph illustrates the Bumper Mechanism. The deck of the MTM is uncambered at the bow to permit the Bumper Frame to lie flat on the deck. This frame protrudes around the gunwhales. The Bumper Switch is located at the point of dissection on the after side of the Bumper Frame. The Anti-boom Lever is in the stowed position. Refer to Photograph Number 11 for a view of this lever in the anti-boom position. The main bursting charge of 660 pounds is mounted in the hatch aft of the Bumper Frame.



PHOTOGRAPH NUMBER 11

This photograph illustrates the Anti-boom Lever in anti-boom position. This lever extends approximately 13 inches below the surface of the water and is hooked outward at the lower end. Refer to Photograph Number 10 for a view of this lever in the stowed position.

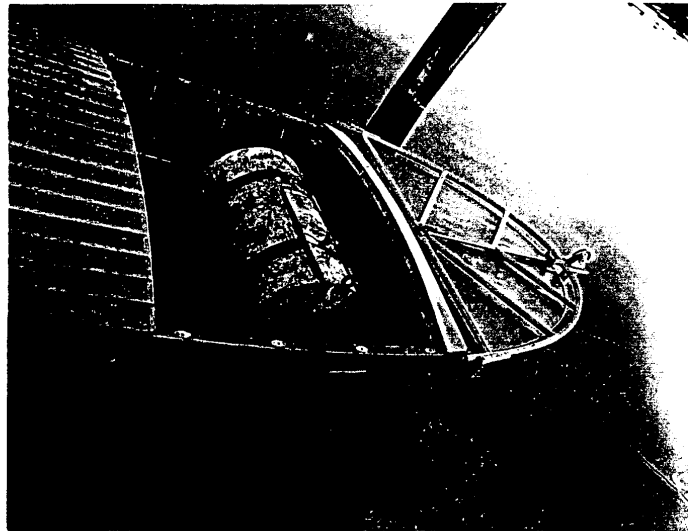

PHOTOGRAPH NUMBER 12

This photograph shows the main bursting charge in position. This charge is mounted on a jig in the explosive compartment. This charge weighs 660 pounds. The Bumper Frame can be seen forward of the charge. This Bumper Frame is the initiating switch for detonation of the main charge.

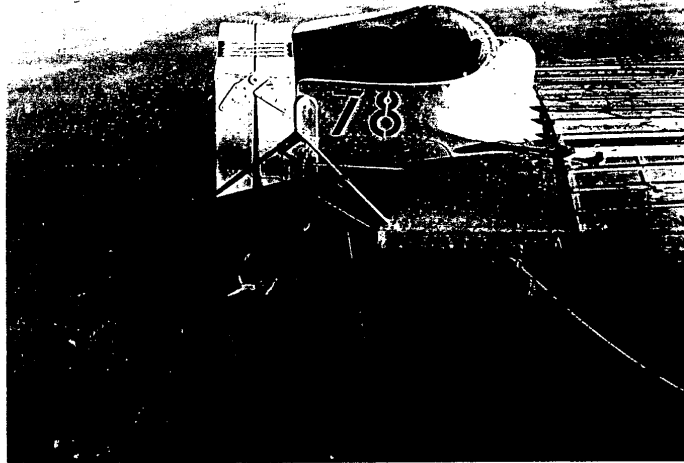

PHOTOGRAPH NUMBER 13

This photograph shows the pilot's cockpit. The pilot's escape raft is in the carrying position on the right side of the cockpit. The cowling on the forward side of the cockpit is a compass housing. The propeller and propeller shaft are almost in the fully retracted position.



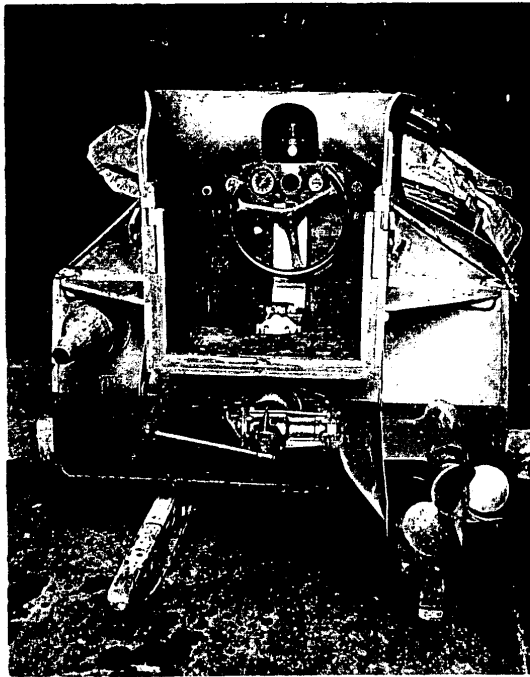

PHOTOGRAPH NUMBER 14

This photograph illustrates the stern of the MTM. The pilot's escape raft has been removed from the after side of the cockpit. Located on the port side just below deck level is the exhaust transom. The cockpit extends several inches aft of the stern. The propeller and propeller shaft are in the fully retracted position. Refer to Photograph Number 15 for a view of the propeller and propeller shaft in the fully extended position. Refer to Photograph Number 16 for a detail view of the pilot's cockpit.

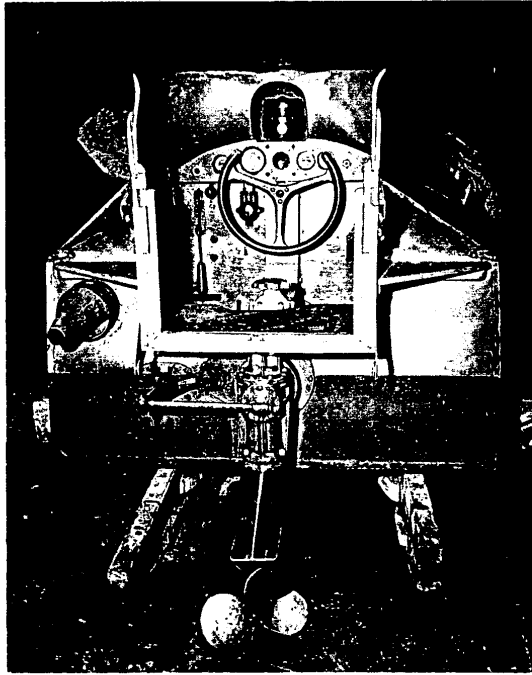

PHOTOGRAPH NUMBER 15

This photograph illustrates the propeller and propeller shaft in the fully extended position. The propeller may be used in any intermediate position between the fully extended and fully retracted positions. Refer to Photograph Number 14 for a view of the propeller and propeller shaft in the fully retracted position. Refer to Photograph Number 16 for a detail view of the pilot's cockpit.

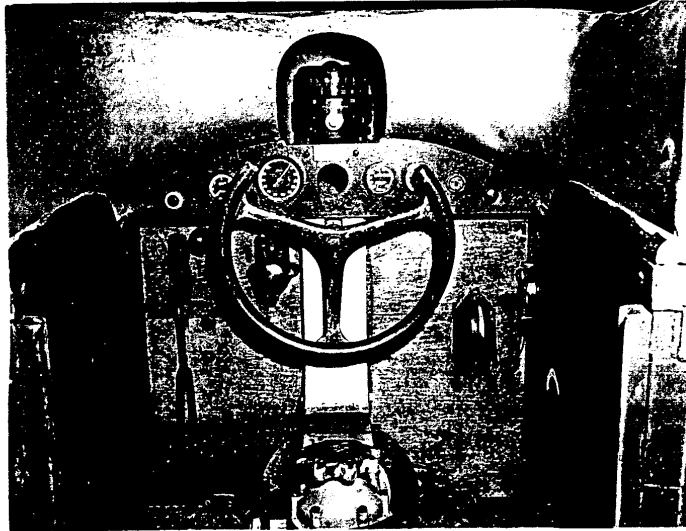

PHOTOGRAPH NUMBER 16

This photograph illustrates the interior of the pilot's cockpit. The steering wheel is cut away at the top. Above the steering wheel is the instrument panel. Above the instrument panel is mounted a vertical card aircraft compass. The throttle is located to the right of the steering wheel. The "cocking lever", "detonation choice" switch, and the propeller retracting lever are to the left of the steering wheel. Refer to Photographs Number 14 and 15 for other views of the pilot's cockpit.



PHOTOGRAPH NUMBER 17

This photograph shows the MTM traveling at 25 knots. The bow rides high in the water and the stern low. Note the head and shoulders of the operator protruding above the combing around the pilot's cockpit.

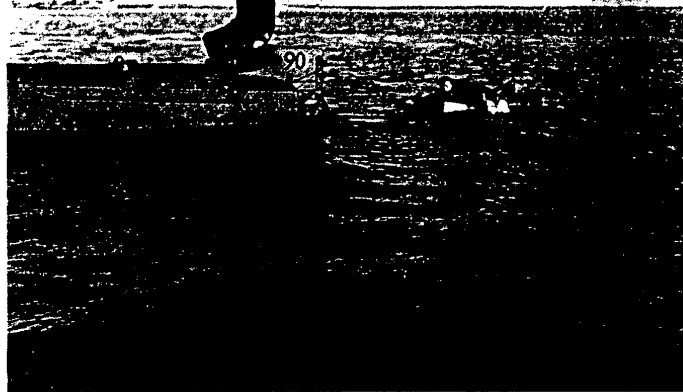

PHOTOGRAPH NUMBER 18

This photograph shows the pilot of the MTM floating on the pilot's escape raft. This pilot wears waterproof clothing. Note the size of the cockpit in comparison to the officer aboard.

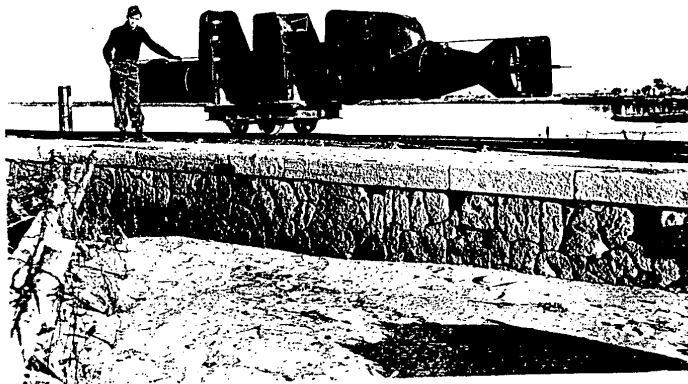

PHOTOGRAPH NUMBER 19

This photograph illustrates a full view of the "Chariot". The three distinct superstructures can be seen. The two operators seats are located in the two cockpits between the superstructures. Note the size in comparison with the man standing alongside.

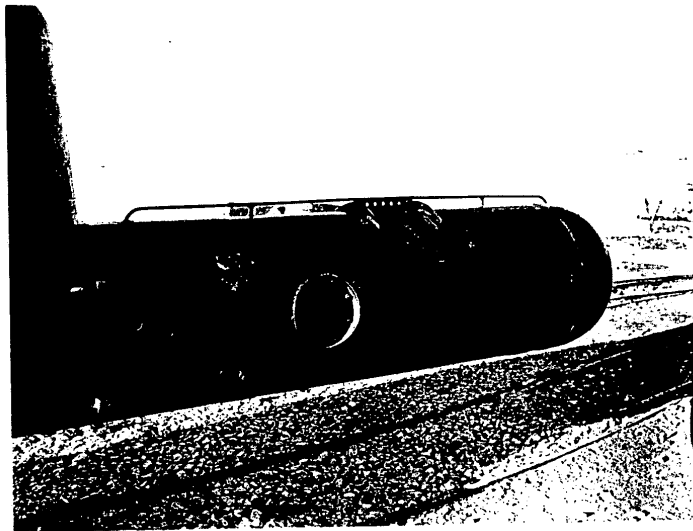

PHOTOGRAPH NUMBER 20

This photograph illustrates the warhead of the "Chariot". This warhead contains 595 pounds of explosive and is detachable. The line of detachment can be seen at the far left. The steel rod at the topside of the warhead is for attachment of suspension cables which hold the warhead under the keel of the target ship. The circular cavity on the starboard side of the warhead is for the insertion of a time delay mechanism.

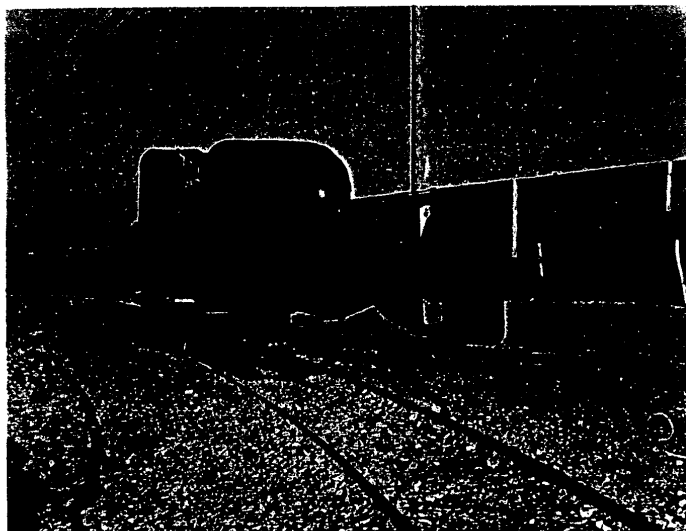

PHOTOGRAPH NUMBER 21

This photograph illustrates the tail mechanism, the tail assembly and the after side of the aft superstructure. The vertical section of the tail mechanism is the rudder. The horizontal section is the elevator. The propeller is located within the cylindrical plinth. This plinth protects the propeller and reinforces the tail mechanism. The rudder and elevator control cables lead to the forward operator's cockpit.



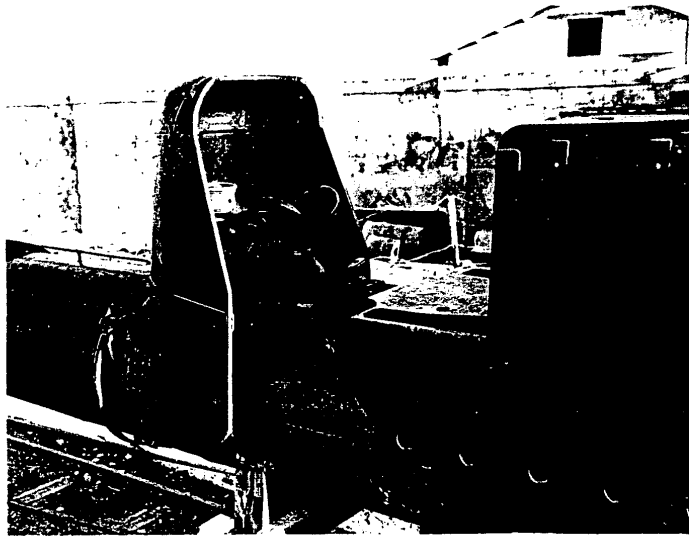

PHOTOGRAPH NUMBER 22

This photograph illustrates the forward pilot's cockpit. The tubular hand lever centrally located is the universal steering lever. The instrument panel and compass are located in front of the steering lever. The forward superstructure protects the forward pilot from wind and waves and also protects the instruments.

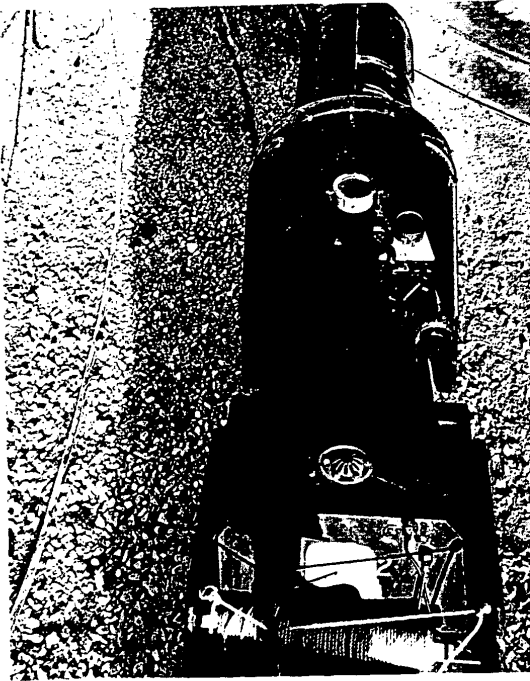

PHOTOGRAPH NUMBER 23

This photograph illustrates the forward pilot's cockpit and the topside of the midships superstructure. Note the intake and outlet opening on the top of the midships superstructure. This opening is a part of the immersion chamber which is located inside the midships superstructure. The forward side of this superstructure serves as a back rest for the forward pilot.

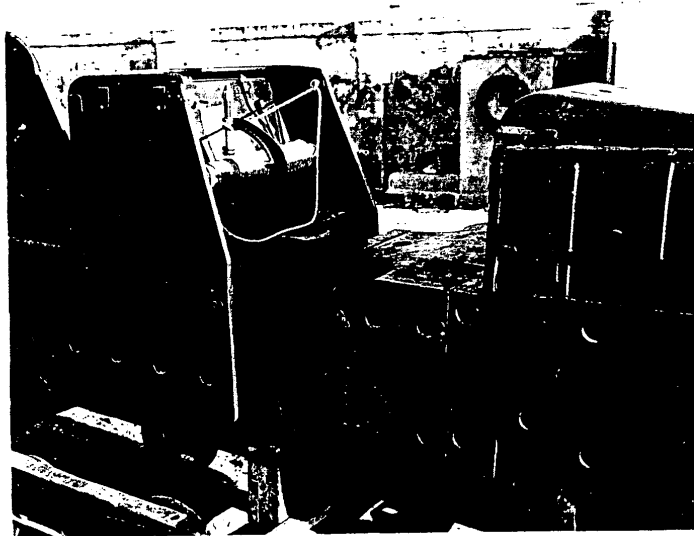

PHOTOGRAPH NUMBER 24

This photograph illustrates the midships superstructure. The aft operator sits in the space between the midships and aft superstructures. The lever which operates the immersion chamber is located at the base of this superstructure. The clamp on the after side of this superstructure fits onto the bilge keel of the target ship. (Two clamps are necessary, one for each bilge keel). The spool of line is used to suspend the detachable warhead beneath the target ship. One end of line is attached to the bilge keel clamp. The other end of the line is attached to the steel rod on the topside of the warhead.

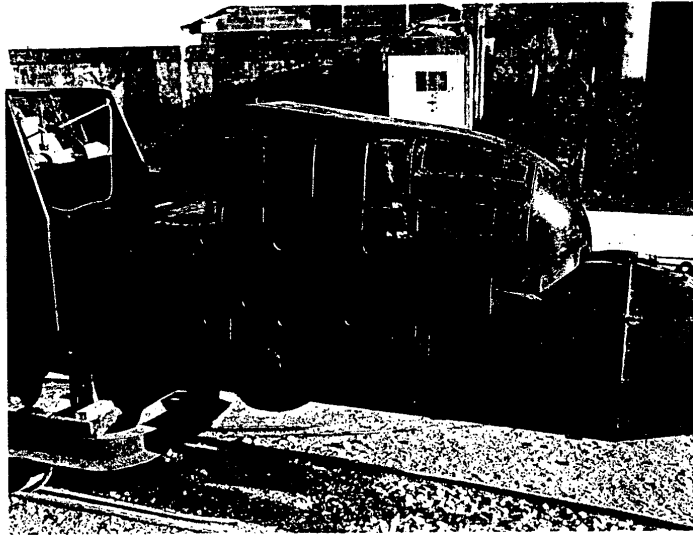

PHOTOGRAPH NUMBER 23

This photograph illustrates the streamlined design of the aft'er superstructure. This superstructure serves as a back rest for the aft operator.

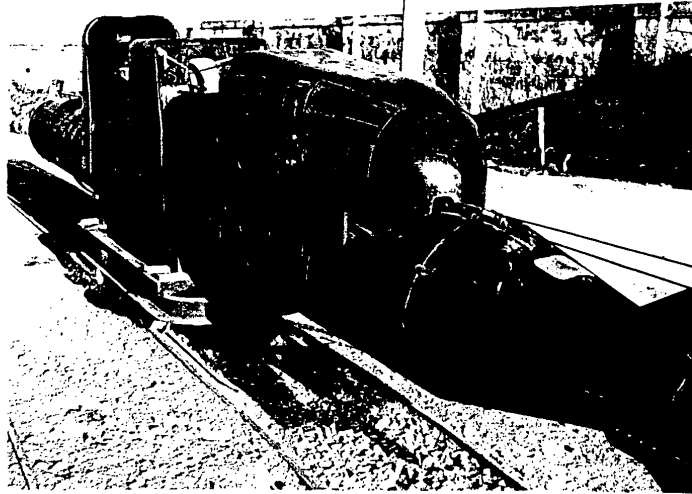

PHOTOGRAPH NUMBER 26

This photograph shows the conical tail assembly of the "Chariot." The rudder and elevator control cables pass through the after superstructure and to the forward pilot's seat.



PHOTOGRAPH NO. 27      PHOTOGRAPH NO. 28      PHOTOGRAPH NO. 29

These photographs illustrate the rubberized linen outer garment worn by the "Chariot" operator. The two inner garments made of light weight India rubber can not be seen in these photographs. An underwater breathing unit lies at the feet of each operator. Photographs Number 27 and 28 show front views of the outer garment and Photograph Number 29 shows a back view. The model in Photograph Number 28 wears the underwater shoes, while the model in Photographs Number 27 and 29 does not wear the underwater shoes.



PHOTOGRAPH NUMBER 30

This photograph shows two "Chariot" operators in the water with the "Chariot." The forward operator is in position to submerge and the aft operator is about to take his place behind the forward operator. Both men wear the underwater breathing apparatus and special clothing used by the Italian "Chariot" operators. The breathing bag of the underwater breathing unit can be seen strapped high on the chest of the seated operator.



PHOTOGRAPH NUMBER 31

This photograph shows the "Chariot" submerging.



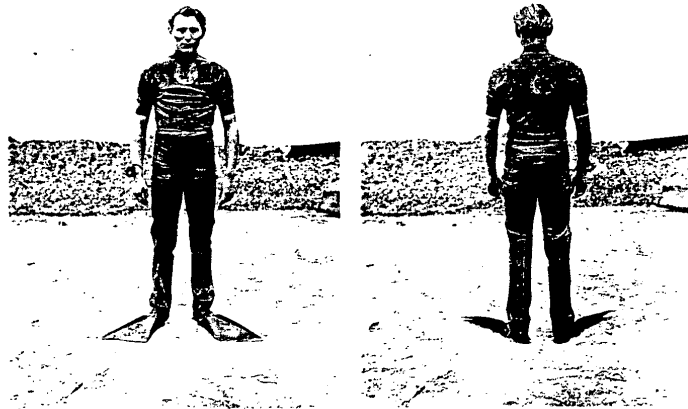

PHOTOGRAPH NUMBER 32

PHOTOGRAPH NUMBER 33

These photographs show the front and back view of the underwater swimmers suit which is used by Italian gamma operators. This suit is made in three pieces. It is constructed of waterproof, lightweight India rubber. The three pieces of this suit are the trousers, the top piece and the cumberbund. The trousers extend up to the armpits. The top piece extends half way between the crotch and the knees. The cumberbund is worn around the waist. This operator is also wearing American type foot fins. The underwater swim suit is worn over long woolen underwear.



PHOTOGRAPH NUMBER 34



PHOTOGRAPH NUMBER 35

These photographs give a front and back view of the limpeteer's vest. This vest is made of canvas and is equipped with loops for carrying limpets and other gamma gear.



PHOTOGRAPH NUMBER 36



PHOTOGRAPH NUMBER 37

These photographs show a front and back view of a gamma operator with full equipment. In addition to the underwater swim suit, foot fins and the limpeteer's vest, this model is wearing an Italian type gamma breathing apparatus. The canvas breathing bag is strapped high on his chest. The oxygen bottle is strapped under the breathing bag. The rubber connecting tube extends from the top of the breathing bag and the mouth piece is in the operators mouth. The operator wears an underwater nose clip. He is carrying a deflated, Mae-West type, limpet at his left hip. On his right wrist the operator wears an underwater compass. This operator wears the protective eye piece pushed back onto his forehead. A camouflage head net covers this operators head and shoulders.

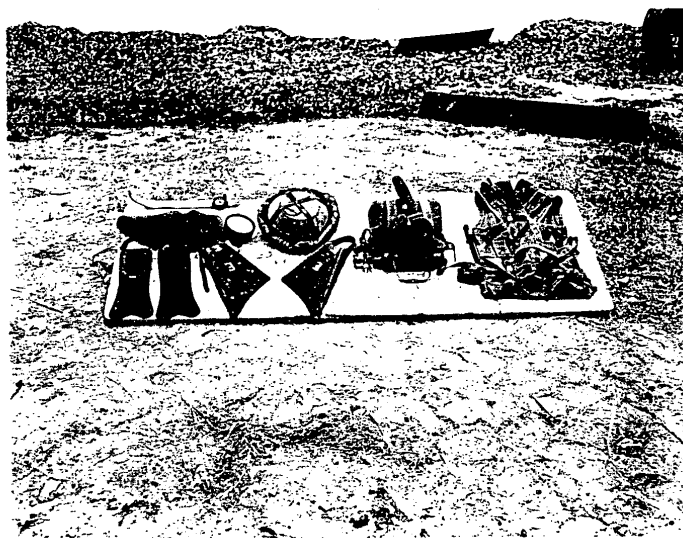

PHOTOGRAPH NUMBER 38

This is a photograph of several items of gamma equipment. From left to right these items are: Italian type foot fins; a camouflage head net; an underwater compass, Italian type; a protective eye piece; a pneumatic or Mae-West type limpet; American type foot fins; an underwater breathing apparatus, Italian type; and a limpeteer's vest. The American type foot fins (marked "E") have been adopted by the Italians.

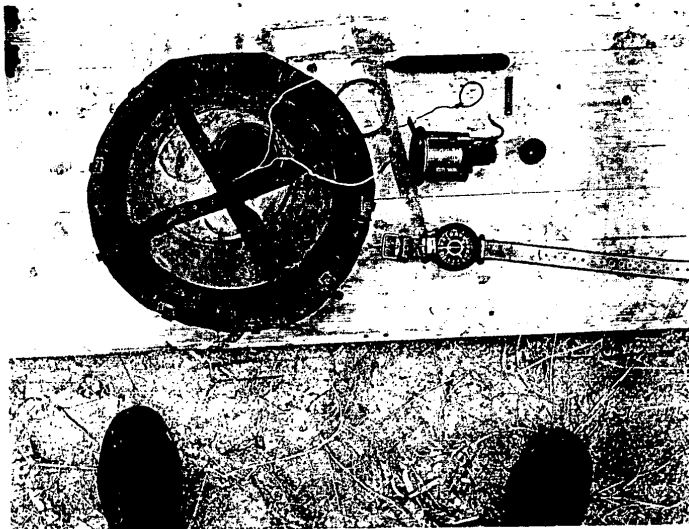

PHOTOGRAPH NUMBER 39

This photograph shows a deflated Mae-West type limpet. The delay mechanism fits into the cylindrical indentation in the explosive container. The disassembled delay mechanism is to the right of the limpet. The vial above the disassembled delay mechanism is the compressed air vial. This vial is sealed inside the deflated Mae-West tube and inflates the tube when the vial is broken. Below the disassembled delay mechanism is the underwater compass. An optical prism can be seen at the left of the compass dial. This prism permits Italian gamma men to read the compass while swimming on the back.

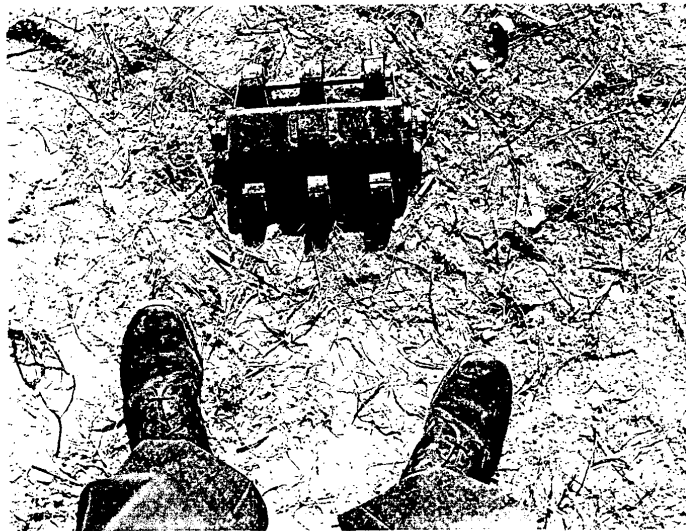

PHOTOGRAPH NUMBER 40

This photograph shows the Italian magnetic type limpet. The explosive container is the central section. The magnets are on either side of the explosive container. The Italian gamma men have discarded this type limpet in favor of the Mae-West type limpet.

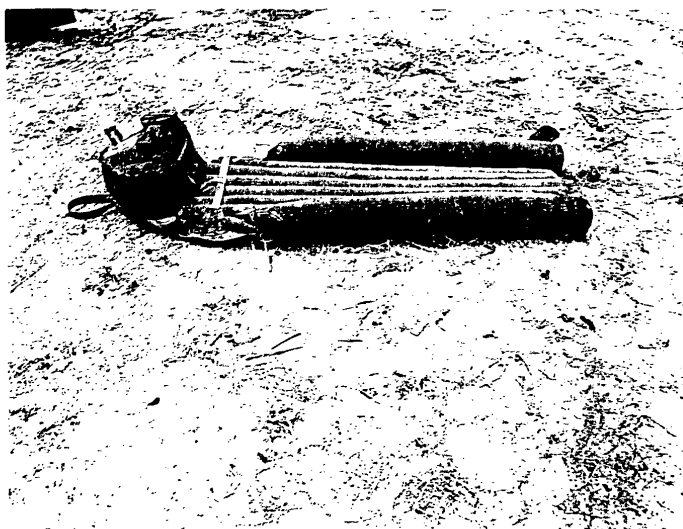

PHOTOGRAPH NUMBER 41

This photograph shows the Matarrassino. This one man float is made of rubberized canvas. The raised section at the bow is the chin rest. On the starboard side of the chin rest is a built in bellows. The Matarrassino is used by the Italian Navy to increase the range of gamma operators.

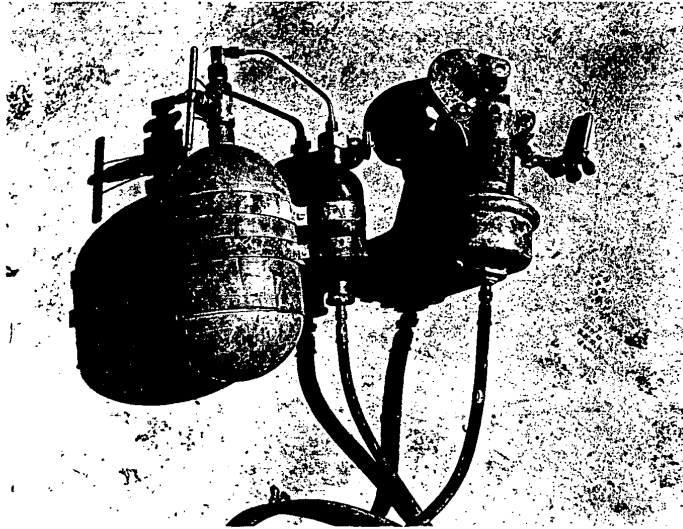

PHOTOGRAPH NUMBER 42

This photograph illustrates the silent pneumatic cable and net cutter. The large ellipsoid canister contains the oxygen and the small ellipsoid canister contains hydraulic fluid oil. The rubber hose that leads from the oil canister is secured to the cylindrical unit which holds and cuts the cable.



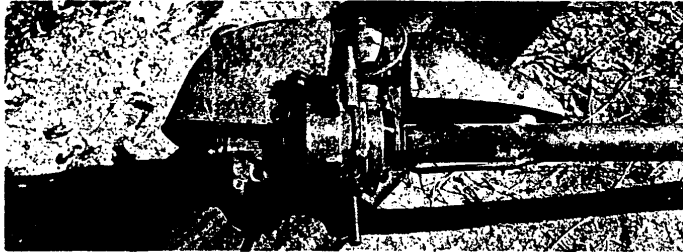

PHOTOGRAPH NUMBER 43

PHOTOGRAPH NUMBER 44

These photographs illustrate the Italian gasoline rubber mattress motor. This one cylinder engine is not satisfactory because it is not silent.



PHOTOGRAPH NUMBER 45

This photograph shows the MTSM-MTM operators group which has been recommended by Captain Forza for duty with O.S.S. These men are, from left to right:

T. V. Luigi Fazzioni  
C.2° Mecc. Luigi Zoppis  
2°C. Nocch. Pietro Castelli  
2°C. M. N. Cofredo Carolini  
T. V. Corrado Degual

The officer at the far left operated the MTM boat which sunk the heavy cruiser F.K.S. York at Suda Bay. All of these men have had operational experience.



PHOTOGRAPH NUMBER 46

This photograph shows the "Chariot" operators who have been recommended by Captain Forza for employment by C.S.S. These men, from left to right, are:

Capt. G. N. Antonio Marcegna  
Pal. Spartaco Schergat  
Ten. Vasc. Giorzio Badessi  
S.C. Pal. Carlo Pessel

The officer at the far left operated the "Chariot" which sunk the battleship H.M.S. Queen Elizabeth at Alexandria. All of these men have had operational experience.



PHOTOGRAPH NUMBER 47

This is a photograph of Ten. Vasc. Luigi Durand De La Penne, a "Chariot" operator who is included in the group recommended by Captain Forza for employment with O.S.S. This officer operated the "Chariot" which sunk the battleship H.M.S. Valiant at Alexandria. He also participated in the joint British-Italian "Chariot" operation at La Spezia, Italy.



PHOTOGRAPH NUMBER 48

This photograph shows the gamma operators who have been recommended by Captain Forza for employment by O.S.S. These men, from left to right, are:

S.T.V. Nicola Conte  
S.C. Pal. Evelino Marcolini  
Serg. S.T. Celestino Ballabio  
S.C. Pal. Giuseppe Cugielmo  
2<sup>o</sup>C. Cam. P.S. Virgilio Ricci

These men are highly trained but have had no operational experience.



PHOTOGRAPH NUMBER 49

This photograph shows the surface equipment technicians who have been recommended by Captain Forza for employment by O.S.S. These men are, from left to right:

C.1<sup>st</sup>Cl. Romeo Venturoli  
Carp. Antonio Carattino  
C.2<sup>nd</sup>Sil. Luigi Vianello  
S.C.M.N. Giovanni Monti  
2<sup>nd</sup>C. Torp. Edoardo Andolfi



PHOTOGRAPH NUMBER 50

This photograph shows the subsurface equipment technicians who have been recommended by Captain Forza for employment by O.S.S. These men, from left to right, are:

C.3<sup>a</sup> M.M. Alfredo Montanari  
Serg. M. Eraldo Coleluppi  
Capt. C.M. Sebastiano Battaglia  
Torp. Egidio Lavone  
2<sup>o</sup>C. Cann. Elvino Bianchi

The officer in the center is the chief engineer of the Mezzi d'Assalto group.