



Director of
Central
Intelligence

~~Top Secret~~

Soviet Reactions to Stealth

CIA HISTORICAL REVIEW PROGRAM
RELEASE AS SANITIZED

1 OCT 1999

Special National Intelligence Estimate

~~WARNING: The material in this document is sensitive. Distribution of this Estimate is strictly limited to those officials who require access to the subject matter for the performance of their duties.~~

~~Top Secret~~

SNI : 11-719-85/L

Aug 51 1985

Cop 54

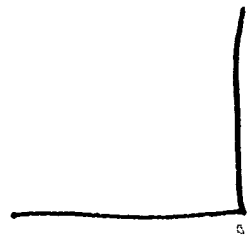
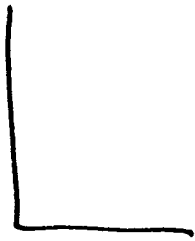
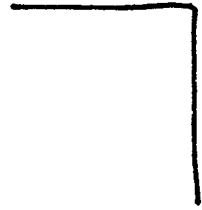

~~TOP SECRET~~

SNIE 11-7/9-85/L

SOVIET REACTIONS
TO STEALTH

Information available as of 28 May 1985 was used in the preparation of this Estimate, which was approved by the National Foreign Intelligence Board on 26 June 1985.

~~WARNING: The material in this document is sensitive. Distribution of this Estimate is strictly limited to those officials who require access to the subject matter for the performance of their duties.~~

~~TOP SECRET~~

THIS ESTIMATE IS ISSUED BY THE DIRECTOR OF CENTRAL INTELLIGENCE.

THE NATIONAL FOREIGN INTELLIGENCE BOARD CONCURS.

The following intelligence organizations participated in the preparation of the Estimate:

The Central Intelligence Agency, the Defense Intelligence Agency, the National Security Agency, and the intelligence organization of the Department of State.

Also Participating:

The Assistant Chief of Staff for Intelligence, Department of the Army

The Director of Naval Intelligence, Department of the Navy

The Assistant Chief of Staff, Intelligence, Department of the Air Force

CONTENTS

	<i>Page</i>
SCOPE NOTE	1
DEFINITIONS	3
KEY JUDGMENTS	5
DISCUSSION	9
The Stealth Concept	9
The Counter-Stealth Potential of Current and Near-Term Soviet Systems	9
Early Warning Radar Systems	9
Fighter Aircraft Systems	12
Surface-to-Air Missile Systems	13
Antiaircraft Artillery Systems	15
Command, Control, and Communications Systems	15
Future Soviet Technical Responses	16
Early Warning Radar Systems	16
Fighter Aircraft Systems	16
Surface-to-Air Missile Systems	17
Command, Control, and Communications Systems	17
Ballistic Missile Defenses	17
Other Defense Options	17
Prospective Soviet Stealth Developments	18
The Impact of the Soviet R&D Process	18
Incorporating Stealth Vehicles in Soviet Military Planning	18
Acquiring and Using Stealth Technology	19
Research Facilities	19
Aerodynamic Systems	21
Ballistic Missile Systems	23
Intelligence Gaps	23
ANNEX: Bibliography	27

SCOPE NOTE

In recent years, the United States has developed a variety of *design techniques* that will reduce the energy reflected by or radiated from aerodynamic vehicles and thereby decrease the likelihood of detection by enemy radar, infrared, and other sensors. The United States has also made significant strides toward the development of *advanced technologies* for the same purpose. This combination of innovative design and use of advanced technologies is known collectively as Stealth.

The well-publicized US Stealth development effort surely has generated concern among Soviet military planners about defense against low-signature and Stealth vehicles. In addition to the need for increasing the depth of its defenses by fielding more defensive weapons of existing types, the USSR will have to consider research and development programs to improve the ability of those defenses to detect, track, and destroy Stealth vehicles. The degree of success that the Soviets achieve in these endeavors is certain to influence US military programs, strategy, and tactics.

We also anticipate that the Soviets will develop systems of their own that incorporate signature-reduction designs and technologies. The US R&D community must know as far in advance as possible the means by which the Soviets will reduce system detectability and the degree of their success. This will be necessary to aid in the development of US countermeasures and to augment the US Stealth program because Soviet approaches may differ considerably from those under consideration for US systems.

This Special National Intelligence Estimate is an effort to assess at the national level the Soviet capability and intention to respond to the US challenge. It presents our evaluation both of the defensive methods and technologies we believe the Soviets will employ to counter the US deployment of Stealth systems and of their technical capabilities to develop indigenous offensive low-signature and Stealth vehicles. The SNIE is restricted to discussing only aerodynamic and ballistic missile systems over a 10-year period. It also identifies collection and analytic gaps that must be filled in order for the Community to provide broader, more detailed studies in the future.

DEFINITIONS

Signature: The characteristic spectrum of radiated energy from the object. The source of energy may be the object itself, an incidental source whose energy is reradiated from the object, or a specific source whose energy is reradiated from the object. (Respective examples are infrared energy from an engine, visual energy from an object in sunlight, and transmitted radar energy returning to a radar receiver.)

Low Signature (Low-Observable Technology): Characteristic of any existing system—such as an aircraft, cruise missile, reentry vehicle, or spacecraft—that has been modified to reduce its signature. Such vehicles can become less detectable to enemy sensors within the limits imposed by the original design. Signature reduction for selected aspect angles or for all radiated or reradiated energy probably cannot be achieved for these systems.

Stealth (Very-Low-Observable Technology): The sum of innovative design techniques and advanced technologies as expressed in a *future* aerodynamic, missile, or space system developed to minimize external signatures. Such systems will achieve very low signature levels through special design to include careful shaping, by infrared and electronic emission suppression, and by the application of advanced coatings and materials. Signature reduction for any aspect angle can be achieved in this type of design.

Radar Cross Section (RCS): A quantitative measurement of an object's visibility to a radar as determined by the radar energy reflected by the object. The RCS of a vehicle is determined by its shape and construction material, the angle at which the vehicle is viewed, and the frequency and polarization of the viewing radar. RCS is usually expressed in terms of square meters.

Infrared Radiation (IR): Emitted or reflected heat energy in the near visible light frequencies. The total IR signature of a vehicle is the sum of its emissions, reflections, and engine exhaust. IR signature is customarily measured in units of watts per steradian as a function of wavelength.

KEY JUDGMENTS

Soviet Counter-Stealth

The Soviets are well aware of US plans to develop Stealth aerodynamic vehicles; nevertheless, we judge that their air defenses will remain vulnerable to penetration by Stealth aerodynamic systems for at least the next decade. This judgment is based on a number of factors that include:

- The limitations of existing Soviet sensors and information-processing systems, which were designed for use against high-signature vehicles.
- The massive and capital-intensive nature of Soviet air defenses, which necessitates incremental modification rather than wholesale replacement.
- The Soviets' lack of sophisticated measurement ranges, which inhibits their development of counters to the threat posed by Stealth.
- The length of the Soviet R&D cycle, which almost certainly will delay the introduction of totally new defensive systems until after 1995.

In the near term, the Soviets almost certainly will place a higher priority on developing defenses against US Stealth vehicles than on developing offensive Stealth systems of their own. Indeed, the Soviets already have made certain incremental modifications to currently available defensive systems in reaction to the US deployment of cruise missiles—which naturally have the low radar cross section, low infrared signature, and low electronic emission characteristics typical of a Stealth vehicle.

The critical factor in determining the degree of success that Soviet air defenses will enjoy against low-signature and Stealth targets is the availability of adequate and timely warning information. Therefore, we expect the Soviets' near-term responses to include:

- Upgrading the sensors and signal processors in current systems.
- Increasing the depth of their defenses by extending ground-based and naval radar and fighter coverage offshore using Mainstay AWACS aircraft, aerial refueling, and a new generation of more capable interceptor aircraft.

- Further pairing of dissimilar types of radars to fill altitude and range detection gaps.
- Increasing the numbers of selected detection and defensive systems.
- Adding mobile surface-to-air missiles (SAMs) to the inventory to complicate penetration planning.
- Increasing decentralized decisionmaking to counter overloading of their existing command and control system.
- Additional netting of early warning, ground-controlled-intercept, and SAM radars.

In the longer term, the Soviets are likely to seek technological solutions to the deficiencies in their air defenses that will persist despite the near-term improvements. We believe these will include developing:

- High-power, low-frequency conventional radars incorporating new signal processors and electronic counter-countermeasures (ECCM).
- Multistatic radars.
- Laser radars.
- Acoustic detection systems.
- Improved infrared search and track sets (IRST).
- Long-range air-to-air and surface-to-air missiles with multi-mode terminal seekers.
- Fully automated command and control systems connected by digital data links.

Soviet Stealth Developments

The Soviets have an excellent theoretical knowledge of electromagnetics and traditional signature-reduction technologies. However, achieving Stealth is dependent on the integration of shaping and other signature-reducing technologies into a weapon system. [

]we doubt that Soviet designers have as yet decided on an overall conceptual approach to any Stealth design. Therefore, while the Soviets probably will begin within five years to modify existing designs to reduce their external signatures, the length of the development cycle makes it unlikely that they could field an unmanned Stealth vehicle before 1995 or a manned Stealth platform before 2000. To prolong the

service life of existing aerodynamic systems—and to control the risks associated with Stealth development—their initial attempt to produce a Stealth vehicle is likely to be an air-to-surface missile, followed by manned systems such as reconnaissance aircraft or tactical bombers, which depend on defense avoidance for survival.

The Soviets have shown an interest in signature-reducing technologies with broad application to a variety of aerodynamic vehicles and have acquired related technical information, materials, and manufacturing equipment from a variety of foreign sources. We periodically acquire information from articles in technical journals or from technical intelligence sources that leads us to believe that independent research efforts are continuing in:

- Radar cross section theory.
- Radar-absorbing materials.
- Automated flight controls.
- Infrared signature reduction.
- Electronics emission reduction.

The Soviets have three outdoor radar cross section ranges, the most prominent of which are at Kalinin and Voronezh. [

] These facilities will contribute to both counter-Stealth and offensive Stealth developments but represent a level of technology several years behind that of the United States.

Moscow has applied signature-reduction and -enhancement techniques to ballistic missile reentry vehicles since the late 1960s. The objective of this program might be to deploy a mix of reentry vehicles, decoys, and other penetration aids that offer a variety of radar signatures in a single payload in order to complicate targeting for antiballistic missile defenses.

[

]

[

]

Figure 1
Design Considerations for Stealth Aircraft

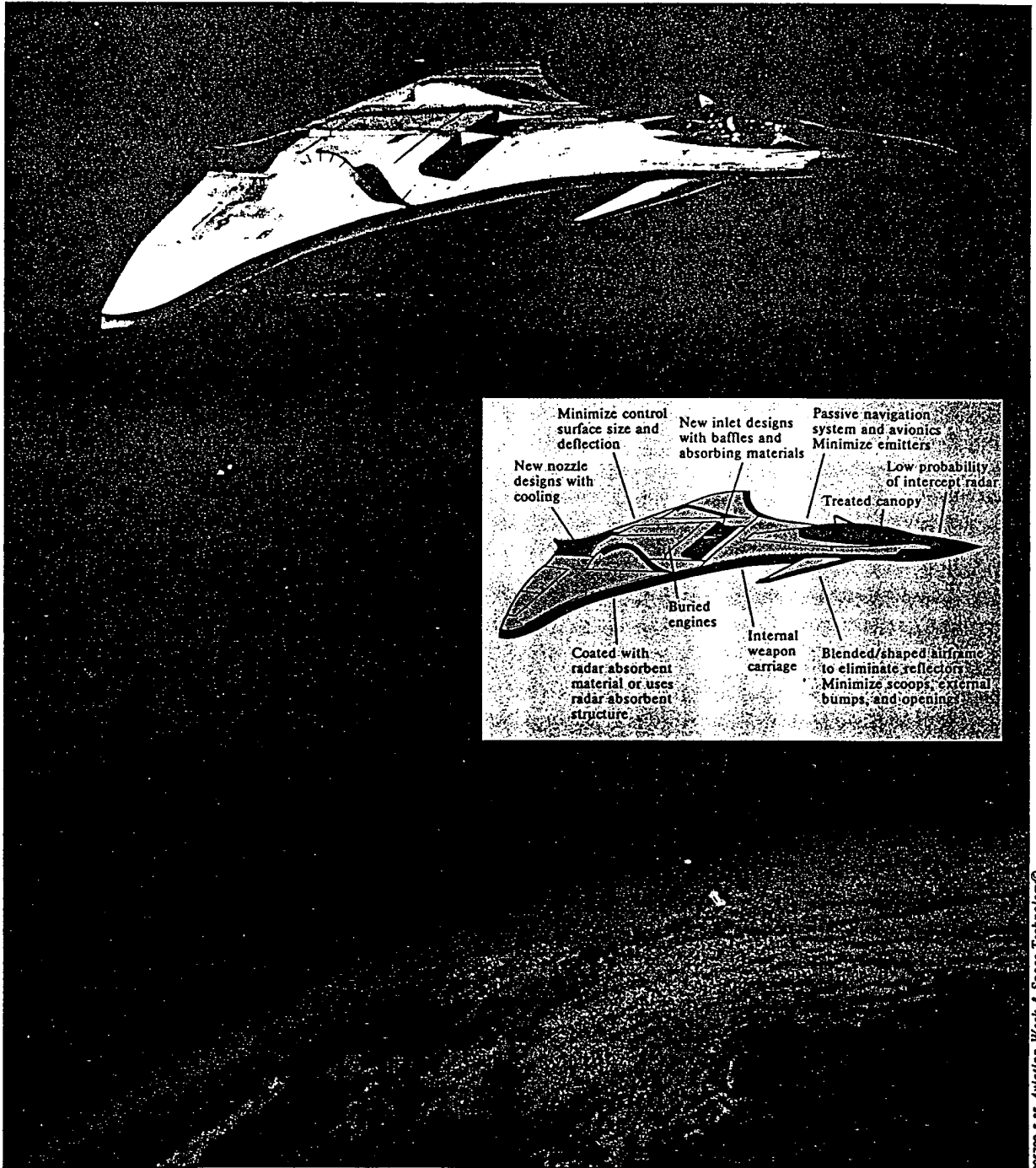

303700 5-85 Aviation Week & Space Technology ©

DISCUSSION

The Stealth Concept

1. The objective of the US aerodynamic Stealth program is to achieve and maintain a high-confidence capability to penetrate the continuously improving Soviet defenses, which rely on radar, infrared, and visual sensors to provide target acquisition, identification, and tracking data to controllers of interceptor aircraft, surface-to-air missiles, and antiaircraft artillery. If attacking vehicles—aircraft, and cruise and ballistic missiles—were not acquired by Soviet sensors or if acquisition were delayed beyond the reaction time of their defensive network, the attacking force would be able to penetrate to its target without suffering an unacceptable rate of attrition. Existing vehicles, modified to reduce their radar cross section (RCS), infrared (IR) signatures, and electronic emissions, will degrade the capability of most current Soviet defensive systems and render some others obsolete, but other factors must be considered in order to penetrate future Soviet defenses. Among these future considerations are acoustics, contrails, and reflected light.

2. Developing a Stealth vehicle requires that all of these factors be considered from design inception. Shaping to reduce radar cross section is the most critical factor in designing a Stealth vehicle; reducing infrared emissions from the vehicle's propulsion system without degrading performance is also a major design challenge. Because a vehicle's electronic emissions can be tracked by SIGINT systems, passive electronic subsystems or those designed to have a low probability of intercept must also be developed. Figure 1 illustrates some of the desirable features of a Stealth vehicle.

The Counter-Stealth Potential of Current and Near-Term Soviet Systems

3. The Soviets are well aware that the United States plans to improve its capability to penetrate future Soviet air defenses by developing aerodynamic vehicles with reduced external signatures, although they almost certainly consider the impending introduction of Stealth technology as only the latest of a number of technical and tactical changes that have forced the Soviets to react (see inset). Moscow perceives the

United States to have a significant lead in the applicable technologies and probably has committed substantial resources to research efforts devoted to counter the US systems.

4. Over the last two decades, the Soviets have spent roughly as much on developing and deploying a strategic defense-in-depth as they have their offensive forces. They have established an air defense system using a layered concept that compensates for the shortcomings of the individual elements, but this approach has resulted in an air defense network so massive and capital intensive that we believe their near-term response to any new threat will be limited to system improvement by incremental modification. The modifications already begun by the Soviets in response to the US deployment of the cruise missile—a system that inherently has a low radar cross section and low IR signature—constitute their initial response to Stealth deployment. In the longer term, we expect Moscow to develop new technologies and operational concepts that better match the increased penetration threat of US follow-on systems, but for the next five to 10 years the Soviets will be forced to rely on defensive systems already in place or expected to enter their inventory soon.

Early Warning Radar Systems

5. The critical factor in determining the degree of success that Soviet air defenses will enjoy against low-signature and Stealth targets is the availability of adequate sensors and signal processing. The existing Soviet air defense network is alerted by an extensive network of ground-based acquisition radars. The Soviets will have several thousand early warning radars of some 13 types in service by 1990. Although some of these have an excellent theoretical capability to detect small targets under controlled conditions, detection ranges would be severely degraded by low-level penetration tactics, background clutter approximating the return of Stealth vehicles, and other operational considerations.

6. In the near term, we expect the Soviets to deploy combinations of these systems in order to maximize their detection capabilities. VHF radars such as the Tall King C radar—also used as the acquisition radar for the SA-5 surface-to-air missile and for ground-controlled intercept—have some capability to detect

Soviet Perceptions of the US Stealth Program

... A great deal of attention in the United States is devoted to expanding its aviation capabilities in order to overcome the air defenses of the Warsaw Pact countries. To achieve this goal, the United States is conducting the work on the "Stealth" program, which is attempting to develop methods that would substantially complicate detection of aircraft through air defense means using the principles of radio location or heat-seeking.

The "Stealth" aircraft development program is being conducted by a number of large US aerospace firms. A contract for 7.3 billion dollars for designing the future strategic ATB bomber was granted to the Northrop Corporation. The Lockheed Company, using the experience it gained in designing the SR-71 and A-11 aircraft, is at present building 29 reconnaissance aircraft which have received the designation CSIRS. Their construction is being financed by the project for designing the future ATF fighter aircraft. The Boeing, Grumman, and Vought companies are also participating in this work. In fiscal year 1982 alone, the United States spent nearly 1 billion dollars on this development work. ...

... According to American military experts, the development and deployment of "Stealth" aircraft will greatly increase the surprise use of aircraft, because of a sharp decrease in the distance at which they can be detected, and it will also decrease the effectiveness of anti-aircraft guided missiles, because of the decrease in the EPR and an increase in fluctuating errors when aiming missiles. Shortcomings of such aircraft include a certain decrease in aerodynamic characteristics, a relatively small combat load because of the presumed

absence of external pods, as well as a limitation in using navigational systems for operational activities and communications.

Although research in the "Stealth" program, judging from Western press reports, is still in the experimental stage, the United States is already trying to determine future uses for "Stealth" technology in designing new types of tactical fighter aircraft, reconnaissance aircraft, and various unmanned systems and winged missiles. The main attention of the American administration, however, is directed toward the development of strategic bomber aviation.

In accordance with the modernization plan for the strategic forces of the United States Air Force, serial production is being planned for the ATB bombers in 1988-1989, immediately following the completion of the planned production of 100 Rockwell B-1B bombers. The ATB aircraft will be rigorously tested in the process of B-1B production. Thus, the B-1B bomber fulfills two functions: It is an intermediary strategic aircraft for penetrating the air defenses of a probable enemy, and it serves as a guarantee in the event of failure of the Stealth concept.

If the ATB bomber is developed successfully, it can be deployed in 1991. In that case, some 100 of these aircraft will be accomplishing missions of penetrating air defenses instead of the B-1B bombers, which would then be used only as carriers for winged missiles to be released outside the air defense zone of the enemy.

The Moscow Journal of Anti-Aircraft Defenses, March 1983

Unclassified

low radar cross section targets operating at high altitudes but are less effective against such targets at low altitudes. We believe the Soviets are more likely to pair the Tall King with more effective low-altitude sensors—like Big Back, Tall Rack, and height finders—that are already available, rather than invest in a major modification to the Tall King itself.

7. Lower frequency radars (that is, VHF) are more effective against low radar cross section targets because the radar wavelength approximates the length of the platform (see figure 2). They are, however, more susceptible to ground clutter. The Soviets have a new VHF early warning radar, the Tall Rack, under development. We expect this system, which uses an antenna mast about 30 meters high, to be effective against low radar cross section vehicles operating at both high and low altitudes. If this new system is developed successfully, it could be deployed in the late 1980s.

8. In addition to ground-based early warning assets, the Soviets are deploying their new IL-76 Mainstay AWACS aircraft (see figure 3), which will be used to improve their offshore early warning capability. The radar on this aircraft has a fair-to-good capability against low-signature targets and a poor capability against Stealth targets at high or low altitudes, over land or over water. The Mainstay's detection, tracking, and command and control capabilities will be an excellent adjunct to interceptors and SAM batteries facing conventional and, to a lesser degree, low-signature threats. Target track data will be relayed from Mainstay to ground, naval, and airborne defensive systems through data links, thereby alleviating some of the operational problems imposed by low-signature and Stealth targets. We expect 27 to 36 Mainstay aircraft to be in the Soviet inventory by 1990.

Radar Capabilities Against Low Radar Cross Section Targets

The capability of a radar to detect a target depends on many factors, including the radar cross section (σ) of the target and the distance (R) of the target from the radar. The relationship between these factors is expressed by the radar range equation:

$$P_r = \frac{P_t G_t^2 \sigma \lambda^2}{(4\pi)^3 R^4}$$

At a given frequency ($f = \frac{c}{\lambda}$) the ratio of the received-to-transmitted signal decreases at the rate of $\frac{1}{R^4}$ so that:

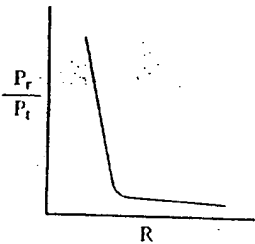

The radar cross section is itself a function of frequency. At high frequencies, it approaches a constant value. At low frequencies, the radar cross section peaks where the radar wavelength approximates the size of some part of the target, such as its overall length or wing width—this phenomenon is referred to as resonance. At very low frequencies, the radar cross section decreases to zero.

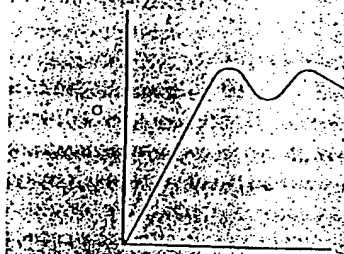

The radar range equation may seem to indicate that a measurable signal will be returned to the radar for very small values of radar cross section (since R^4 approaches zero much faster than radar cross section approaches zero, the ratio of radar cross section to R^4 remains large even for small radar cross sections). However, for targets with low radar cross sections, other objects in the environment—birds, insects, and vegetation, for example—contribute as much to the signal as does the target itself. This background return is called clutter. Most Soviet radars do not have the necessary clutter rejection electronics to allow them to discriminate between true targets and clutter of the same or larger radar cross section. Estimates of a radar's theoretical capabilities in the hypothetical absence of clutter grossly overstate the capabilities of that radar against a low radar cross section target. An accurate discussion of a specific radar's capabilities to detect a particular low radar cross section target must include the effects of frequency, clutter, target altitude, aspect, and flight profile. Such a discussion is beyond the scope of this paper.

Fighter Aircraft Systems

9. We do not expect the overall force level of Soviet interceptor aircraft to change appreciably through 1990, but the incorporation of aircraft now entering production or in the final stages of flight test will dramatically improve Soviet air defenses. By 1990, about 40 percent of the Soviet fighter inventory will consist of MIG-31 Foxhound, SU-27 Flanker, and MIG-29 Fulcrum aircraft equipped with pulsed-Doppler radars with digital data processing systems, capable of conducting lookdown/shutdown attacks—a capability essential for defending against cruise missiles and low-signature aircraft but possessed by only a small percentage of the current Soviet fighter inventory.

10. All three aircraft—the heart of Soviet air defense systems for at least the next decade—are equipped with improved radars, fire-control systems, and air-to-air missiles.

These three aircraft are also equipped with infrared search track (IRST) sets.

In a lookdown mode or bad weather, this tracking capability would be severely degraded. Nevertheless, IRST sets provide an adjunct to radar attack by permitting the operator to passively track a target or to attack a target in an ECM environment if some other sensor provides range data. If the Soviets perceive that US developments in reducing radar cross section cannot be countered by radar improvements alone, they may turn increasingly to infrared or other passive sensors for detection, tracking, and missile guidance.

11. In addition to defending against penetrating fighter and bomber aircraft, the Soviets are threatened with offshore launches of cruise missiles. We judge

Figure 4
New Soviet Fighters

SU-27 Flanker

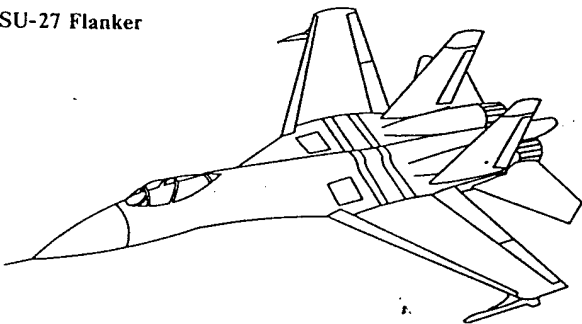

MIG-29 Fulcrum

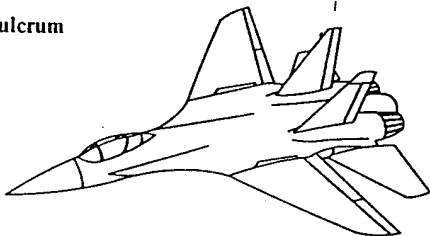

305703 5-85

that production of new tanker and AWACS aircraft will support the Soviets' plans to move defensive forces further from their coastline in order to intercept cruise-missile-carrying aircraft before missile launch. If the newer fighters also are equipped for aerial refueling, the Soviets could extend their defensive barrier far enough offshore to provide the prelaunch intercept capability we believe they are seeking.

12. Those targets that successfully penetrate the offshore barrier will be more difficult to intercept over land, even though the Soviets have extensive land-based defenses. Low-altitude penetration tactics have already reduced track time and imposed clutter problems on Soviet radar and infrared sensors; reduced-signature systems will further increase the stress on their defenses. Almost half of the Soviet interceptor aircraft will have some capability to attack low-signature targets, including cruise missiles, in the 1990 time frame but probably will have little capability against Stealth vehicles before 1995. Moreover, the effectiveness of individual air defense systems will be determined in large part by the evolution of Soviet air

defense doctrine, their future command and control structure, and their technological response to the increased threat.

Surface-to-Air Missile Systems

13. By 1990 the Soviets will have at least 14 surface-to-air missile (SAM) systems in the field and may have begun deploying ground-based laser defenses. As in the case of Soviet early warning radars, some SAM systems could threaten low-signature and Stealth vehicles under certain conditions, but operational factors would reduce their effectiveness under wartime conditions.

14. The SA-5, the USSR's longest range SAM, has a limited ability to attack low-signature targets, especially those operated at low altitudes. Nevertheless, because of the Soviets' significant investment in this system and its deployment in Eastern Europe, we anticipate that Moscow will improve the acquisition and tracking radars currently associated with the SA-5.

15. The SA-10 (see figure 5), the Soviet Union's most modern strategic SAM, is the first designed to defend against low-altitude aircraft and air-to-surface missiles.

The SA-10 will be fielded in two versions: the transportable version—the SA-10A—is now being deployed; the mobile version—the SA-X-10B—is still in development.

16. The SA-X-12, in development since 1973, is the Soviets' latest tactical radar-guided SAM. Its design—which incorporates two versions of an interceptor missile—allows the system to attack both high- and low-altitude targets ranging from cruise missiles to tactical ballistic missiles. Its ability to track low radar cross section targets could be improved by modifying its acquisition and engagement radars to include better clutter rejection in the former and tower mounting for the latter.

17. The Soviets have fielded large numbers of infrared SAM systems designed and developed in the 1960s and 1970s that are highly mobile, easy to conceal, and relatively inexpensive to build. However, present Soviet technology in this area will not pose a significant threat to US low-signature or Stealth vehicles in the near term, because even the newest Soviet

Figure 5
Components of the SA-10 SAM System

Low-Altitude Acquisition Radar (Clam Shell)

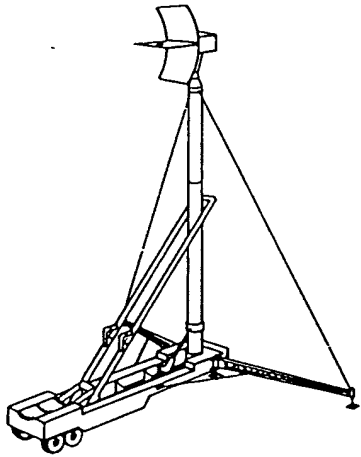

Engagement Radar (Flap Lid)

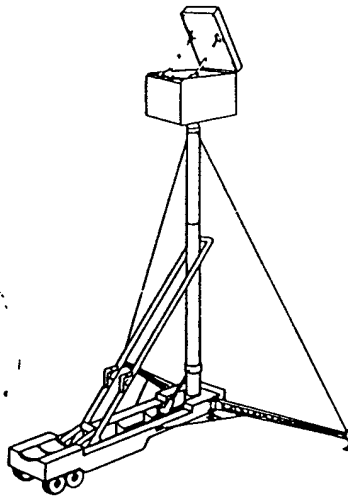

Long-Range Acquisition Radar and Vans (Big Bird)

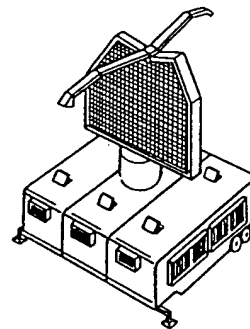

New SA-10 Mobile Engagement Radar

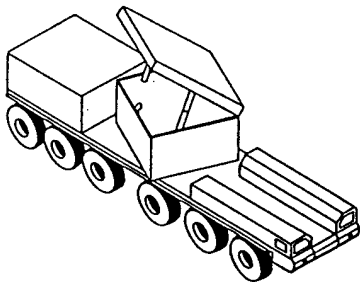

Launcher

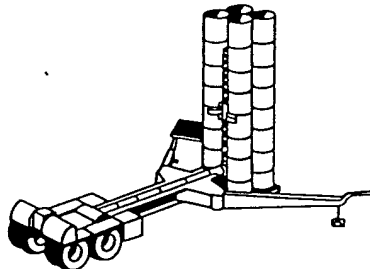

New Self-Propelled SA-10 TEL

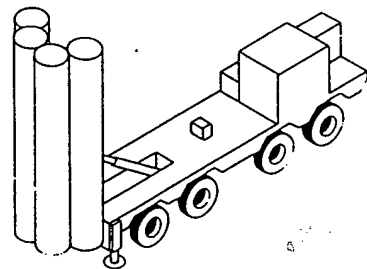

587913 5-83

IR SAMs show only marginal capabilities to attack cruise missiles. Substantial improvements in infrared sensing technology will have to be achieved before these weapons will be capable of attacking US Stealth vehicles.

Antiaircraft Artillery Systems

18. The ZSU-23-4 is the current Soviet mobile radar-directed antiaircraft gun system. It is capable of tracking targets with a radar cross section of 0.01 square meter or larger. The follow-on ZSU-X system could be improved by adding an acquisition radar, improving clutter rejection, eliminating multipath tracking errors, and upgrading its fire-control computer. Because its range would be limited to about 5 kilometers, its usefulness against low-signature and Stealth vehicles is limited to point defense of high-value targets. We expect to see significant numbers of the ZSU-X fielded during the early 1990s.

Command, Control, and Communications Systems

19. The existing Soviet air defense system [great difficulty in tracking conventional aircraft flying at low altitude. Under some conditions, its highly centralized structure can inhibit the rapid flow of information and firing decisions necessary to engage and defeat fast-moving targets. The Soviets recognize that low-signature and Stealth targets would severely stress their current network and are implementing procedural changes as stopgap measures until better systems are available in the 1990s. Decisionmaking is being forced to lower echelons to permit more rapid response to targets. Individual pilots, flight leaders, and SAM battery commanders are being taught to recognize an overload of the command and control system, and are being encouraged to engage targets on their own initiative, using local sensor and computational resources, without awaiting approval and target assignment from their superiors.

20. While Soviet commanders are encouraging the development of autonomous command capabilities to overcome some of the deficiencies in their command and control system, they simultaneously are reinforcing the role of centralized command and control by netting together early warning, ground-control-intercept, and surface-to-air missile radars. The resulting networks capitalize on differences in sensor frequency, output power, and location to present a more complete picture of the aerial situation—particularly with respect to low-altitude penetrators and low-signature

vehicles such as cruise missiles. This sort of information is essential to the orchestration of Soviet air defenses in response to the longer term Stealth threat, but sensor netting may produce overloading of the command and control system. Until technical improvements in data handling and integration are implemented, information from the netted sensors could contribute to the effectiveness of local air defense nodes but would provide only a marginal improvement in the ability of Soviet commanders to manage the overall air battle.

21. Technological improvements will be necessary to correct the hardware limitations apparent in the Soviet air defense network. Existing Soviet command and control systems are based on a one-on-one concept—a single interceptor or SAM on a single target. The new generation of interceptors now being deployed and the SA-10 system are capable of simultaneously engaging multiple targets. As a result, the Lazur ground-controlled intercept system and the Vektor-2 SAM command and control system are being replaced by more capable systems.

22. New air-to-air, air-to-ground, and ground-to-air data links [

] are already providing better air situation information that will allow the Soviets to take full advantage of their new defensive systems. The present objective appears to be one of providing decisionmakers in the cockpit or at the SAM battery level with enough air situation information to make correct engagement decisions. This radical departure from historic Soviet practice is necessitated not only by the decreased reaction time available during engagements with low-signature targets, but also by the belief that intensive electronic countermeasures may degrade command and control, or that integral command, control, and communications nodes may be put out of action. Centralized decisionmaking is ideal, but in the above cases it also should be sufficiently flexible to allow engagement decisions to be made at a level appropriate to the situation. The Soviets will retain centralized decisionmaking whenever possible.

23. The Mainstay AWACS aircraft will enhance the Soviet air defense command and control system by downlinking tracks of targets not visible to ground sensors to ground stations via digital data signal. Target information collected by the Mainstay's radar and IFF (identification friend or foe) system probably includes identification, position, altitude, velocity, and number of targets in a group. We believe the Mainstay can manage up to 12 simultaneous airborne-controlled

intercepts, and control of some intercepts would be accomplished via air-to-air data links monitored by controllers aboard the Mainstay. The command, control, and communications capabilities apparent in the Mainstay system originally resulted from the Soviet perception of the threat posed by low-altitude penetrators. Although the Mainstay has a marginal detection capability, it will serve as an interim Soviet command, control, and communications response to the Stealth threat.

Future Soviet Technical Responses

Early Warning Radar Systems

24. We are aware that the Soviets are developing higher powered early warning and intercept radars with the better resolutions necessary to come to grips with the low-signature and Stealth detection and tracking problem. Soviet radar designers are likely to incorporate VHF and UHF frequencies, increased pulse repetition frequencies, and improved signal processing in their next generation of radars—possibly by developing a pulsed-Doppler processor. They may also develop spread spectrum radars in order to make effective jamming more difficult; however, these would not necessarily have improved capabilities against Stealth vehicles. These newer radars will continue to have built-in electronic counter-countermeasures (ECCM) based on such techniques as side-lobe suppression, waveform diversity, and cross-polarization cancellation.



Fighter Aircraft Systems

26. We are unable to determine the direction that Soviet avionics designers will take—in part because we expect new technologies to emerge—but certain currently available technologies offer the most likely avenues of approach to the problems posed by Stealth. If consistent with past practice, Moscow will upgrade the radar and infrared sensors on its next generation of interceptors in an attempt to meet the Stealth threat. No single technology will correct the deficiencies of current Soviet air intercept radars, but the Soviets are

likely to examine the following technical areas because they offer the greatest potential for improved performance:

- Reduced radar frequency to improve radar cross section detection capability and lessen clutter interference.
- Increased transmitter power, antenna aperture, and sensitivity.
- Increased signal-processing efficiency and clutter reduction through new waveforms.
- Improved subclutter visibility through internal refinements.

27. Future Soviet interceptors are certain to include much-improvedIRST sets to enable Soviet pilots to conduct tailchase intercepts of low-signature vehicles. Current SovietIRST sets are thought to have a very limited capability against low-signature targets and lose effectiveness in clouds or against a cluttered background. If the Soviets are to improve significantly the capability of theirIRST sets, they must develop improved sensors and signal processors that can reject low-altitude ground clutter.

28. The Soviets have developed an autonomous midcourse guidance concept for their radar-guided air-to-air missiles [

29. Articles in Soviet technical journals have discussed laboratory-level optical processing of radar signals, an indication of the Soviets' interest in developing electro-optical adjuncts for airborne detection and tracking of low-signature and Stealth vehicles. Optical processing—an attractive alternative to the high-quality digital technology on which US systems depend—would increase the speed at which radar data could be processed and would allow the detection of smaller, near-noise-level returns by providing greater correlation power and clutter rejection. The Soviets have also demonstrated technology in operational laser rangefinders, which could lead to the development of

laser radar systems for the detection and tracking of targets. However, we have no evidence of such developments at this time.

Surface-to-Air Missile Systems

30. Much of the detection and tracking technology developed for future interceptor aircraft could apply to ground-based SAM systems. Soviet experience in developing IRSTs for aircraft could lead to an advanced ground-based IRST capable of supporting cruise missile engagement by newer and future SAM systems. Such a system would require advanced infrared detector and signal-processing technology. [

31. Over the years, the Soviets have continued to upgrade the capabilities of their radar-directed SAMs to meet the evolving threat to their defenses. [

Command, Control, and Communications Systems

32. As the US deploys and perfects the penetration techniques of vehicles that have progressively lower signatures, we expect the Soviets to continue upgrading their acquisition and tracking radar networks by improving the data-handling capabilities of their command and control systems in order to provide the automated redundant links necessary to handle fast-

moving events throughout the Soviet air defense system. If the Soviets are to cope with the very short reaction times imposed by Stealth targets, they must automate many if not all of the manual operations that inhibit their current air defense system. Automating the system will require development of suitable system architecture, algorithms, and software—areas in which the Soviets most lag Western computer technology. The Soviets are likely to concentrate their resources in this area because of the potential for a high payoff against low-signature and Stealth vehicles.

Ballistic Missile Defenses

33. The Soviets probably believe that application of Stealth technology to US ballistic missile reentry vehicles is farther off. Their current ABM and ballistic missile early warning systems are based primarily on radar, and their launch-detection satellites use IR sensors. The Soviets are actively engaged in research on more advanced ballistic missile defense concepts that could include directed-energy weapons. Should these prove feasible, the Soviets would have to develop more accurate tracking means that might couple optical techniques such as laser or IR tracking with advanced radar concepts to provide a potentially effective counter to Stealth ballistic missile RVs.

Other Defense Options

34. There are many options that the Soviets might take in responding to the Stealth threat that are not technology dependent. Most would be readily apparent to the Intelligence Community and offer no long-term solution to the problems faced by the Soviet air defense system. The options include:

- Increasing the use of AWACS aircraft, aerial refueling, and long-range interceptors to extend defenses. Offshore barriers could be augmented by naval radars, shipborne SAMs, and aircraft carriers.
- Increasing the numbers of radars and SAMs to offset the reductions in range and reaction time imposed by Stealth targets.
- Increasing the use of mobile SAMs to complicate penetration planning.
- Clearing obstacles around SAM sites and mounting more SAM radars on towers to improve line-of-sight and reduce ground clutter.
- Using acoustic tracking nets, human spotters, and visually aimed anti-aircraft artillery.

— Using manmade obstacles such as barrage balloons.

Prospective Soviet Stealth Developments

The Impact of the Soviet R&D Process

35. The speed at which new technologies are incorporated into Soviet offensive forces will be determined by the status of technologies in research and the complexity of the systems entering development. The technology research phase can be shortened by technology transfer if applicable Western technology can be brought to the production line. The overall result is that system development can start earlier than would have otherwise been possible if the Soviets had had to rely on indigenous developments alone. However, Soviet designers tend to select major system technologies early in the development process. The impact of this approach, in terms of development leadtime, is summarized in table 1.

Incorporating Stealth Vehicles into Soviet Military Planning

36. Our judgments on how Soviet military planners might reach a decision to incorporate Stealth technologies in their future forces are admittedly subjective. Nevertheless, Soviet requirements to penetrate NATO's defenses appear to be the most difficult task for their forces for the present. Thus, the Soviets probably calculate that the most immediate need for Stealth technology lies with those forces intended for peripheral strike and tactical air operations, and that Stealth application to intercontinental bomber and long-range cruise missile designs may safely be relegated a lower priority. In the longer term, the Soviets probably

anticipate that the US Strategic Defense Initiative will provide a number of the technologies to improve early warning of an enemy bomber attack and that a US deployment of ballistic missile defenses would be accompanied by air defense modernization.

37. *Peripheral Strike and Tactical Air Forces.* The aerodynamic portion—aircraft and cruise missiles—of Soviet theater forces faces an increasingly capable NATO defense. NATO air defenses, particularly those in Central Europe, and the defenses over US carrier battle groups—the primary target of Soviet naval air units—are rated highly effective by the Soviets. The Soviets have invested heavily in these forces over the last 10 years, deploying SU-24 Fencer and TU-22M Backfire bombers that were developed before signature reduction was a significant design criterion. These aircraft probably will be the backbone of the peripheral bomber forces throughout the rest of the century. The Soviets probably see a need to arm these aircraft with low-signature air-to-surface missiles by 1990, and perhaps field Stealth missiles by 1995. After 1992, they will field follow-on aircraft that are likely to incorporate some low-signature technologies.

38. Soviet tactical air force operations are conducted by air-superiority and ground attack fighters, and reconnaissance aircraft. The Soviets have just completed developing the MIG-29 Fulcrum and the SU-27 Flanker—designs that do not appear to incorporate signature-reduction technologies. We judge that these aircraft will be the primary fighters in the Soviet tactical air inventory for years to come and probably will be modified with some low-signature features during their operational lives. The design of a Stealth fighter using technology currently available to the Soviets probably would require sacrifices in flight performance that they are likely to consider unacceptable in an air-to-air combat aircraft where maneuverability is an important aspect of survivability. We therefore doubt the Soviets will field a Stealth fighter before the next century.

39. On the other hand, the current Soviet tactical bomber and reconnaissance force consists principally of aircraft whose mid-1960's designs offer little potential for increased range or payload, or decreased external signature. Aircraft in these categories would be less affected by the sacrifices in flight performance forced by current Stealth technology because their pilots have traditionally depended more on avoidance than maneuverability to survive. For these reasons, we believe that an aircraft from one of these two mission areas is likely to be the first manned system to benefit from Soviet Stealth technology.

Table 1
Impact of the Soviet R&D Cycle
on the Availability of Systems
Incorporating Stealth Technologies

Status of Technology	Change to Weapon System	Years to Initial Operational Availability
Available now	Minor modification	5 to 7
	Major modification	10
	New system	10 to 15
In applied research phase	Major modification	10
	New system	15
In exploratory research phase	Major modification	13 to 15
	New system	15 to 20

40. *Intercontinental Forces.* The Soviets are well aware that the US SDI effort is not expected to come to full fruition before the year 2000. This much leadtime may allow the Soviets to investigate a number of signature-reduction techniques and to incorporate effective ones into their next generation of intercontinental weapons. A usually reliable source recently reported that the Soviets already are working on techniques to reduce the IR signatures of their ICBM boosters, an effort consistent with their program to reduce the radar cross section of ballistic reentry vehicles (see section on ballistic missile systems).

41. The Soviets might be especially motivated to incorporate signature-reduction techniques in their long-range cruise missiles and, eventually, their intercontinental bombers. These systems have sufficient flexibility to allow them to be used in a variety of conventional and nuclear roles, and the development of low-signature and Stealth air-launched cruise missiles would extend the effective service life of the generation of bombers now deployed or in development.

Acquiring and Using Stealth Technology

42. Soviet scientists have shown an interest in signature-reduction technologies applicable to a broad cross section of aerodynamic vehicles. They have investigated radar-absorbing paints and materials for several years and have acquired technical information, manufacturing equipment, and materials from several foreign sources. The objects of Soviet technical interest include:

- Radar-absorbing materials that show a high potential to decrease the effectiveness of certain radars and millimeter-wave-guided weapons.
- Large-scale carbonyl iron powder manufacturing facilities. The production capacity the Soviets seek is beyond their normal military or civil requirements.
- Large autoclaves suitable for making composite aircraft parts. The number of autoclaves purchased exceeds their basic research requirement.

43. Developing the technologies required by Stealth vehicles will tax the Soviets, even with foreign technical assistance, but production of such vehicles may be an even more formidable task. Careful attention to quality control—a long-term weakness of Soviet industry—is necessary to minimize the signature of any given design. Retraining production personnel into

highly skilled technicians will be time consuming and will put additional stress on the already burdened Soviet military-product work force.

Research Facilities

44. A prerequisite to developing Stealth vehicles is the ability to measure very small changes in the energy emitted or reflected by prospective designs. The most challenging of these measurements—determining the radar cross section of Stealth designs—must be done on a highly instrumented indoor or outdoor range. While initial radar cross section measurements can be made using precisely built scale models in a compact anechoic chamber, final proof of design testing requires the use of full-scale vehicles and probably can only be done at an outdoor facility.

45. The Soviets are capable of constructing a compact indoor range roughly equivalent to first-generation US facilities. With access to Western technology, the Soviets probably will be able to build indoor ranges in the next five years comparable to those currently in use in the United States. [

46. We have identified three outdoor ranges in the Soviet Union capable of performing radar cross section measurements. The least active of these ranges is at Aralsk. [

47. The range at Kalinin has probably been used to measure the radar cross section of several aerodynamic vehicles. [

48. [Soviets have over the last five years upgraded their outdoor range at Voronezh. [

] This range is environmentally suited

~~TOP SECRET~~

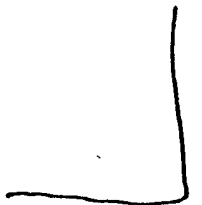
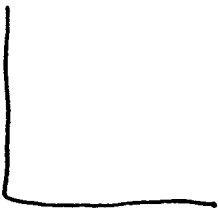
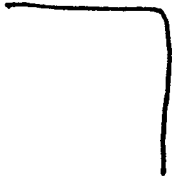
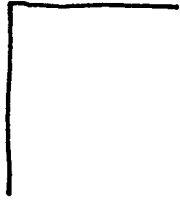

for low radar cross section measurements and, with further development, could be capable of measuring objects with even lower radar cross sections. The Voronezh range is our best candidate for further development of the advanced measurement capability necessary to support both counter-Stealth sensor developments and indigenous low-signature and Stealth vehicle development programs. [

] 49. With the advent of cruise missiles with inherently low radar cross sections, the Soviets require sophisticated facilities capable of measuring the radar cross section of smaller targets. In the past, such US ranges required carefully controlled, graded surfaces extending over great lengths—often several kilometers—against which precisely adjusted transmitters bounce radar waves onto pylon-mounted targets that, in turn, reflect the energy into closely calibrated receiver antennas. No such Soviet ranges are known to exist. Modern range-gating techniques have reduced the requirements for control of ground surfaces. [

Aerodynamic Systems

] 50. Achieving Stealth is dependent on the integration of shaping and signature-reduction technologies into a weapon system. We are aware that for years the Soviets have applied some methods and techniques of signature control—most notably radar return modification, infrared emission reduction, and low probability of intercept signals—to some of their weapon systems. By combining these methods and techniques, the Soviets could design a low-signature flight vehicle; however, we have no evidence that Soviet designers have decided upon a conceptual approach to a Stealth vehicle or that integrated development of an offensive system is under way. They may rely on disclosures from the burgeoning US program to provide a conceptual basis for their indigenous efforts.

] 51. Nevertheless, the Soviets have demonstrated a grasp of applicable design theory and have shown sufficient interest in related research areas to indicate that they are developing some signature-reduction technologies. [

] lead us to believe that several independent research efforts are continuing.

] 52. Articles in Soviet technical publications indicate an understanding of radar cross section prediction and airframe-shaping techniques. The Soviets have conducted extensive research on radar-absorbing materials and have developed a wide range of proven materials upon which their designers may draw. Although the new generation of Soviet fighters reportedly contains 10 to 20 percent composite materials by weight, we have no information on the Soviet approach to the problems posed by bonding and adhesive materials required to apply composite materials successfully to airframe construction.

] 53. Optimum shaping for low radar cross section could result in airframes that are marginally stable in flight. The Soviets may be conducting ground-based research in advanced automated flight controls and fly-by-wire concepts at the Novosibirsk Scientific Institute of Aviation Siberia [

] 54. Reducing the radar and infrared signatures of high-performance turbine engines may well be the pacing factor in the development of any Stealth vehicle. The Soviets have used shielding to reduce the IR signature of the engines on some of their attack helicopters in reaction to the heat-seeking missile threat in Afghanistan, but external shielding of this type tends to increase the size of radar returns. While they have also redesigned helicopter engine exhaust nozzles in an attempt to reduce IR signatures, we are not aware of any Soviet program to reduce the infrared signatures of other types of aerodynamic vehicles.

] 55. The Soviets are progressing rapidly in several electronics fields associated with low-signature vehicle developments. In the area of airborne communications, the Soviets have the necessary technology to develop burst transmitters. These devices communicate by means of short, high-powered bursts that reduce the likelihood of an intercept that would give away the position of the host vehicle. Spread spectrum communications also has a high potential for application to Stealth aircraft; we expect the Soviets to field an airborne spread spectrum system by 1995.

] 56. The Soviets have sufficient technological expertise at hand to satisfy the passive navigation requirements of Stealth vehicles. Laser gyro equipment has been produced in the Soviet Union, and Soviet military authors have noted the capabilities of US short-range navigation aids—forward-looking infrared, low light level TV, and laser subsystems. Projected improvements to the Soviet GLONASS space-based navigation system may be able to support Stealth operations.

57. The Soviets are also progressing rapidly in radar technologies. They have developed an electronically scanned phased-array antenna for the MIG-31 Foxhound and a planar-array antenna for the IL-76 Mainstay AWACS aircraft. They probably will investigate wideband signals and frequency agility techniques in order to reduce the emission signatures of their current airborne radars and meet the requirements of Stealth vehicles. They have already fielded a [] and narrow-band optical systems (laser rangefinders) in the MIG-29 Fulcrum.

58. The Soviets are testing a new generation of air-, ground-, and sea-launched cruise missiles designed in the 1970s that have reasonably low external signatures that could be reduced through judicious aerodynamic shaping and use of radar-absorbing materials. []

Ballistic Missile Systems

59. Renewed US interest in strategic defense places a premium on early identification and very accurate tracking of ballistic missiles, reentry vehicles (RVs), and space systems. The Soviets may attempt to counter future US layered defenses by applying signature-reduction techniques, many of which are equally applicable to aerodynamic, ballistic, or space vehicles. For example, the Intelligence Community has assessed the SS-18 follow-on to have a greater throw weight or range, or a combination of both, based on improvement of its propulsion system. The increased capability could be used to modify the postboost vehicle to carry lower signature reentry vehicles and additional penetration aids and other counter-SDI devices. Over the longer term, the Soviets also might experiment with lower signature propellants and may use other techniques to achieve range and payload performance similar to that of the SS-18. They also may use other signature-lowering techniques like radar-absorbing paints and materials to reduce the vulnerability of their missiles and warheads to intercept.

60. The Soviets probably began to apply signature-control techniques to ballistic missile reentry vehicles in the late 1960s

62. In addition to lowering the signatures of the RVs themselves, the Soviets have been investigating various penetration aids and techniques since the mid-1960s.

Intelligence Gaps

Our calculations indicate that an absorbing material or a conducting layer located within the RV heat shield could reduce the return signal; the magnitude of the reduction depends on the frequency of the incident radar and on the heat shield's dielectric properties and configuration of the conductive layer and heat shield materials. On the basis of this analysis, we conclude that the Soviets currently employ materials to modify the radar cross sections of some of their reentry vehicles.

Table 2
Likely Soviet Counter-Stealth Technology Efforts

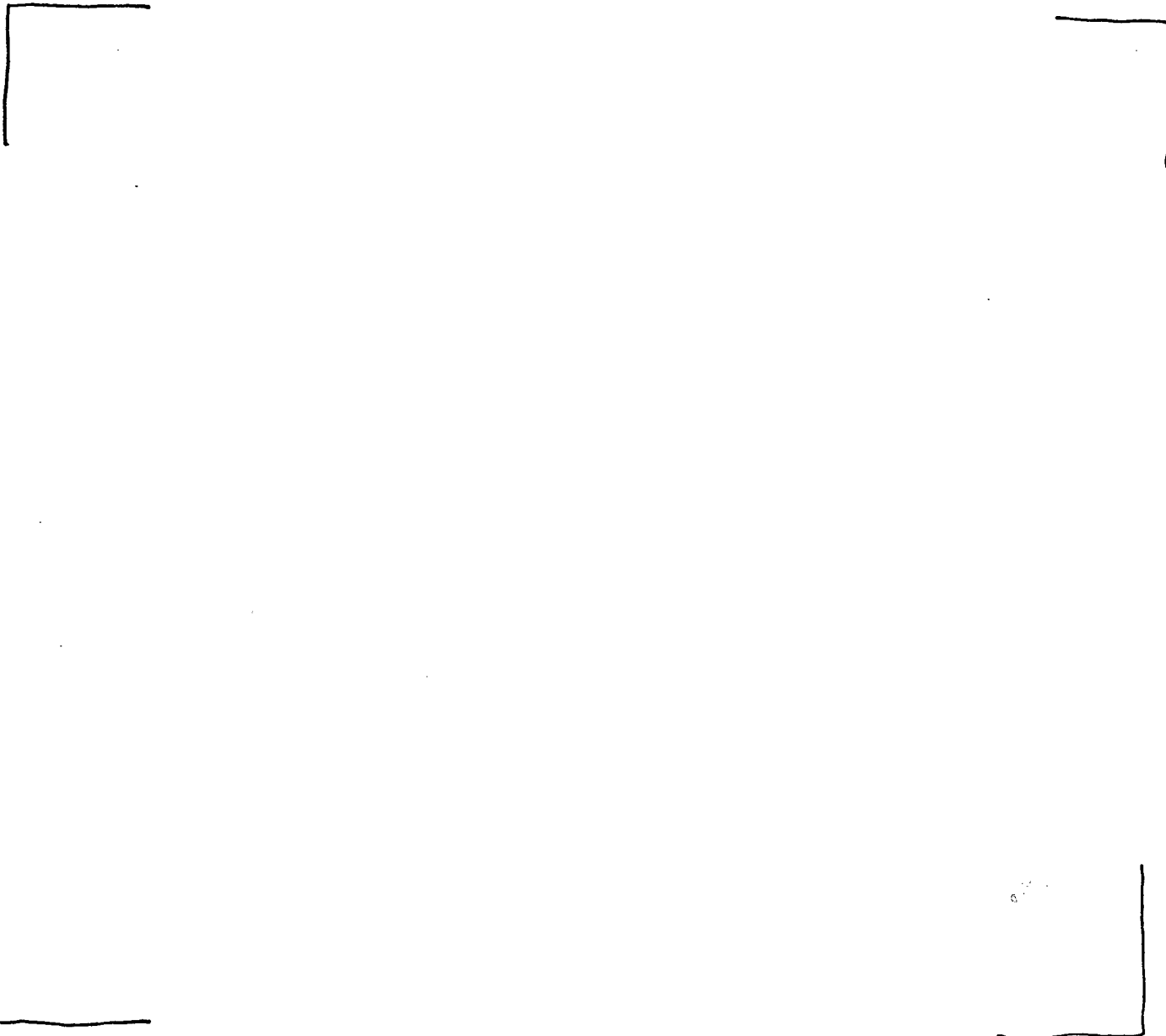
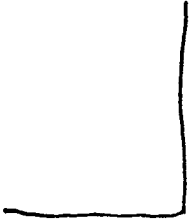
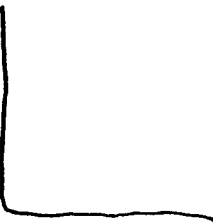

Table 3
Likely Soviet Stealth Technology Efforts



~~TOP SECRET~~

ANNEX
BIBLIOGRAPHY

NIC: *Possible Soviet Responses to the US Strategic Defense Initiative*, NIC M 83-10017, 12
September 1983.

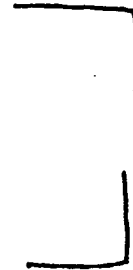

~~Top Secret~~



~~Top Secret~~

~~Top Secret~~