

7 July 88  
1000 hrs  
Fr. MORRO  
Solo

P.I. NONE/HUNGARY  
A.V. NONE.

179010  
864892

A: ACROSS  
RISING  
SMOOTH  
HAND  
B: LAND

SZ: TAN  
LEADING POOL

FOR BLUE  
SAND

179010  
864592

A: CIRCLING  
MOTION  
ENERGETIC  
SOFT.

B: \_\_\_\_\_

179010  
864892

A: ACROSS  
FEAT  
HAND  
SMOOTH  
B: LAND

A: RISING  
VIBRATING  
HAND  
SMOOTH

B: \_\_\_\_\_

2

179010  
864892

A: FANT  
TONS  
SMOOTH

B: \_\_\_\_\_

A1 BARK:  
TENSION

179010  
864892

A: ACROSS  
IRREGULAR  
WINDY  
DUMPY  
SMOOTH  
HAND  
MOTION

B: \_\_\_\_\_

179010  
864892

A: ACROSS  
SMOOTH

B: ~~\_\_\_\_\_~~

A: RESINE  
APPEL  
APPEL  
COURT  
HAND  
UNNAMED

B: STRUCTURE

3

S2: ROUND  
TALL  
DARK  
SOLID  
PLAIN  
HAND  
CURVED

FOR MARK  
BUILDING

FOR BULK  
MINAROT

FOR BULK  
SILO

FOR BULK  
CANTON POWSON

FOR SKETCH:

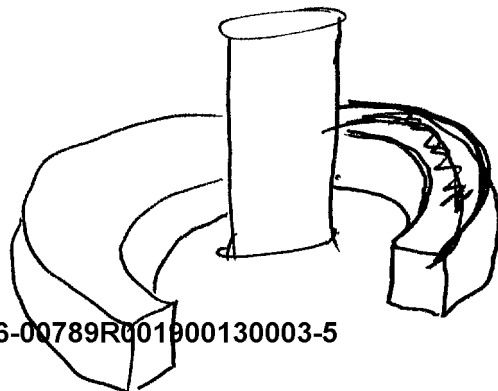

FOR MARK  
CRAY  
COMPUTER

④

179010  
867892

B: BLACK & FOAM  
MOTION  
SMOOTH

D: \_\_\_\_\_

S2: BLUE  
TAN  
BLACK  
HAMP  
SOLID  
TALL  
ROUND

SK:

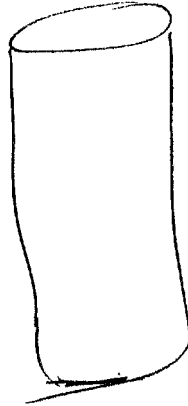

SK:

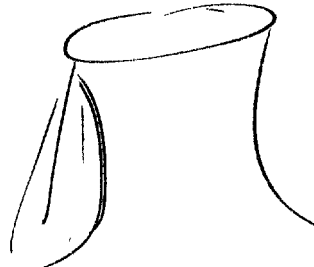

NOE SK:  
NUKE PLANT.

5

179010  
864892

A: rising  
across  
across  
smooth  
B: LAND

179010  
864892

miss one

179010  
864892

A: smooth  
across  
rising  
why  
water  
B: LAND

179010  
864892

A: Bumpy  
across  
jerry  
land  
B: \_\_\_\_\_

④

179010  
864892

A: SCASSI  
TANO  
MANMADO  
B: STRUCTURE

B: REDDISH  
TAN  
BROWN  
TALL  
LONGER  
STRAIGHT

A/S  
VERY URGENT VISUAL  
FROM WIND, BLDG.

179010  
864892

A: SCASSI  
TANO  
MANMADO  
B: STRUCTURE

S2: MOIST FEEL (TO MN)  
DRY ROCK  
BRIGHT  
WARM  
FLAT  
OPEN  
WIDE

SK: ~~WIND~~  
FLAT ROOF  
BELOW  
EDGE

BLDG  
6065

⑦

S2: SUNDOWN

RED BRICK  
FOUNDATION.

S3:

~~BLDG~~

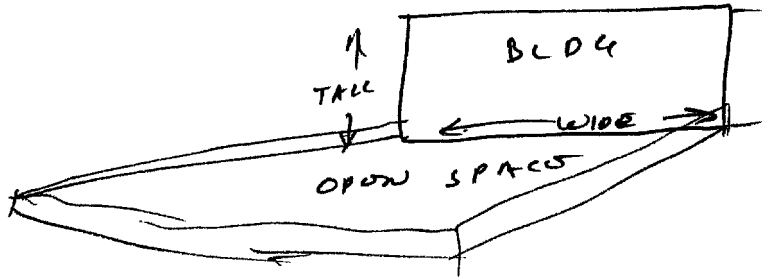

~~S2~~

D

M

OT

(<sup>T</sup>  
OPEN SPACES)

near

als.

FLAT  
HIND  
LADY

PROJESCT

RED BRICK  
PARKING LOT  
INSIDE BLDG.

S2

D

M

OT

(<sup>T</sup>  
BLDG)

1

near

als.

RODISH  
~~BLDG~~  
BLDG

WIDE  
TALL  
SQUARE

S4 1/2

some kind of ROUND thing  
SQUARE BLDG, w/  
STAIRS - UP.

8

HA BK  
SMOKE STACK

54 1/2 IMPRESSION THAT ROUND DOME IS  
PART OF BLDG, BUT NOT PHYSICALLY  
CONNECTED.

MOUSE TO 1 MILE ABOVE THE SITE + DESCRIBED.  
SZ D M ST T I AL ALs.  
SOURCE

Hazy

HA BK  
SURPRISE  
AT AMAZING AMOUNT  
OF AIR POLLUTION!

SZ D M ST T I AL ALs

BLUB  
UNOON  
DNY  
SMELLY

HA BK!  
UHH!  
NOTICELY UNPLEASANT  
ODOR!



(9)

POSITIVE AND VIBRANT 1 MIN UP.

SL D M O T 1 NOC NLS.  
(SICK)

DARK

DARK

LANDS

SL: ~~SL~~ NLS. VALUES VISUAL!

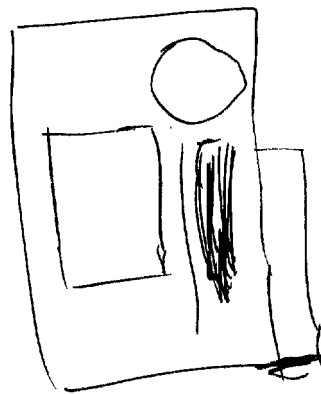

S4 1/2 IMPRESSION OF A LAND RECTANGULAR  
AREA SECTIONED OFF FROM SURROUNDING LAND.  
LAND STRUCTURE IN MIDDLE, W/ ROUND STRUCTURE IN BACK.  
DARK AREA TO ONE SIDE, LIGHT AREA ABOUT & BELOW.  
LONG ADJACENT AREA OFF TO ONE SIDE.

S4 1/2 IMPRESSION OF DRY, RUID LAND, BUT  
LOTS OF UNSEEN VISIBLS.

S4 1/2 SORT - ISOLATED AREA

~~56.~~ ACCESS + DESCRIBE THE PERSONALITY OF SPECIFIC INTEREST.

S L      O      M      O      T      ,      M      n/s.  
(PERSON)

MALE  
FEMALE

CONF MORA:

CONFLICTING IMPRESSIONS OF PERSON: MALE/FEMALE.

AOL BRK!  
HOMOSEXUAL/  
TRANSGESTITO/  
SEX-CHANGE/  
WHO KNOWS WHAT!

ACCESS + DESCRIBE THE PERSONALITY OF SPECIFIC INTEREST.

S L      O      M      O      T      ,      M      n/s.  
~~THIN + YOUNG~~  
(PERSON)

S4 1/2 IMPRESSION OF THE PERSON AS A CONTINUANCE OF A PERSON, RATHER THAN IN PRESENT TIME ONLY.

YOUNG + THIN

BLONDE

AOL BRK!  
ISRAELI THIN  
OF ~~WIT~~  
SUSPECTED WWII  
NAZI.

BREAK: 1040: STONK DRIVES ON LAST AGL:  
BREAK.

ROBINS: 1045

ACCESS + DESCRIBES THE PERSONALITY OF  
SPECIFIC INTEREST.

SZ      D      AI      ST      T      '      NO      A/S.  
(PERSON)

HONEY SET

WOLF DRAGON

GRAY <sup>ING</sup> HAT

CHOPPER FOR LOOK

MEDIUM

S4 1/2 IMPRESSION #1 E1 COLUMN: FEELINGS OVER AN  
IMPERSONAL SHELL WHICH COVERS OTHER FEELINGS.  
TWO LAYERS OF FEELINGS, CLEARLY  
SEPARATED.

ACCESS & DESCRIBE THE PERSONALITY OF  
SPECIFIC INTEREST.

S2            O            M            J            T            I            AN            als.

(PERSON)

INDUSTRIAL  
POLITICAL  
POWERFUL  
IMPORTANT

(PERSON)

EMOTIONLESS  
CALM  
WATCHING  
OBSERVING  
SPECTATOR

S4 1/2 PERSON HAS AN INWARD APPROACH TO  
THE ACTIVITY, AS SIMPLY OBSERVING IT.  
NO ACTIVE DESIRE TO CONTROL IT.

NOT ME.  
TRIAL.

NOT DRIVE BACK BACK ON THE AOR OF A TRIAL.

SESSION END 1053.