

REMOTE VIEWING SESSION DATA

* Remote Viewer : PS 003 *

* Interviewer : FA *

* Observer(s) : _____ *

* _____ *

* _____ *

* Date : 10/01/85 *

* Starting time : 0905 hours, local *

* Site # : 0762 *

* Acquisition by: (CRV) ERV PRV ARV BRV Other _____ *

* Working mode : (GT) HEM Other _____ *

* Feedback class: A (B) C . *

825301
318317

* Ending time : 1125 hours, local *

* Notes : Stage VI TM _____ *

* Highest stage : VI *

* Evaluation : + 4 _____ *

* Actual site : Nazca Lines, Peru _____ *

* RV summary : _____ *

* _____ *

* _____ *

Paul
10485
~~Paul~~
Fr. needs
20755
Fred
0905

825301
318317



A. dross

Confusion break

825301
318317

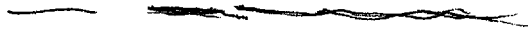

A. dross
red
B. land

A. ayad
fluis
B. wats

A. dross
phi?
B. wats

S-2
misty
grey
red
metal
hollow sound

Confusion
break

2530L
318317

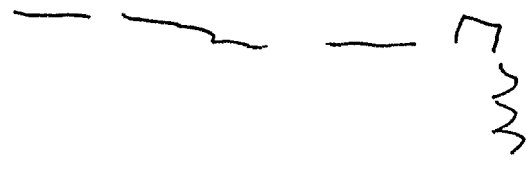

A. K
compression ble
too much break

82530L
318317



A. above
fluid
B. water
compression bleed

530L
318317



A. across
haul

B. law

A. across
fluid

B. wats

A. up rising
angle across
up angl
across
down

B. structure

S-2

- red
- rough
- smooth
- cold
- damp
- rusty
- clammy
- humid
- fog smell
- bank sound
- Clang
- raised up
- angular
- Solid
- A I break
- like

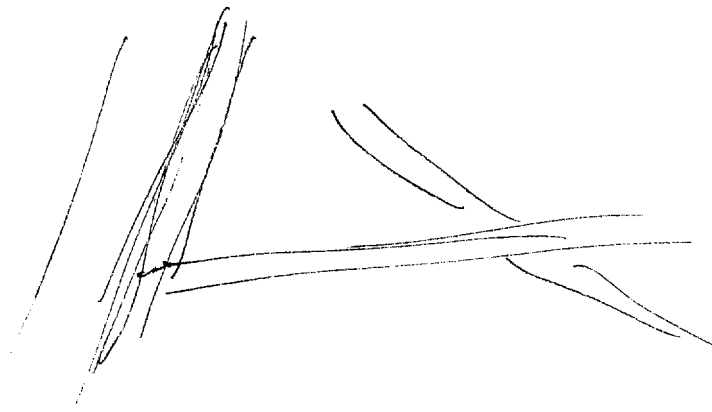

AOL BK
reminds me of
a bridge or
power line
tower

82530L
318317



A. Area
land
flat
B. land

A. dropping
composition break

AOL BK
waterfall

AOL BK
Hydroelectric
facility

2530L
318317



- A. across land flat
- B. land
- A. across any down any down h
- B. structure

S-2
white
gray
smooth
rough
brown
echo

ACL BL
Hoover dam

318317

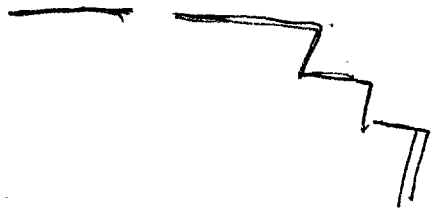

A. across
 base

B. land

A. across
 wet
 down
 and
 away
 angle
 down
 solid

B. structures

S-2
 bed

A 1 BK
 Chills

blade
 grey
 rough
 bumpy
 rounded
 solid
 levels
 squat
 rectangular
 wide

AZ BC
sort of interesting

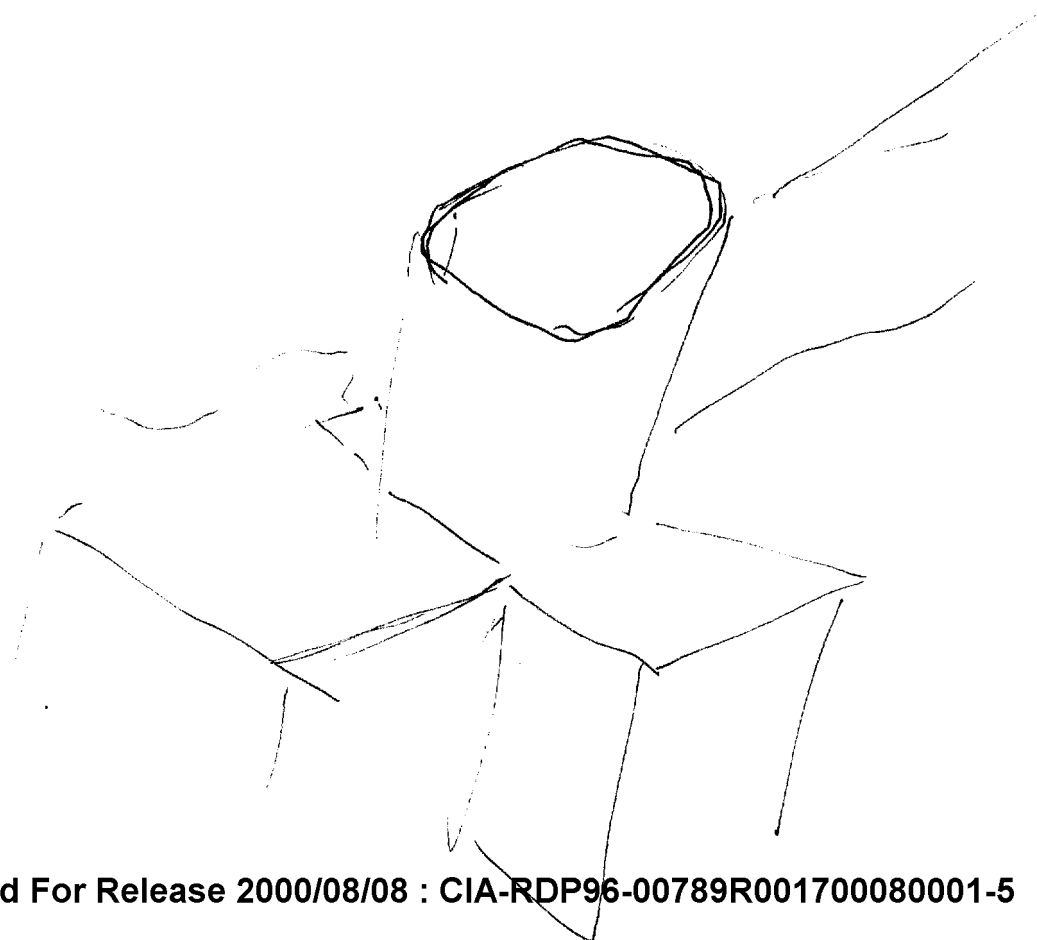
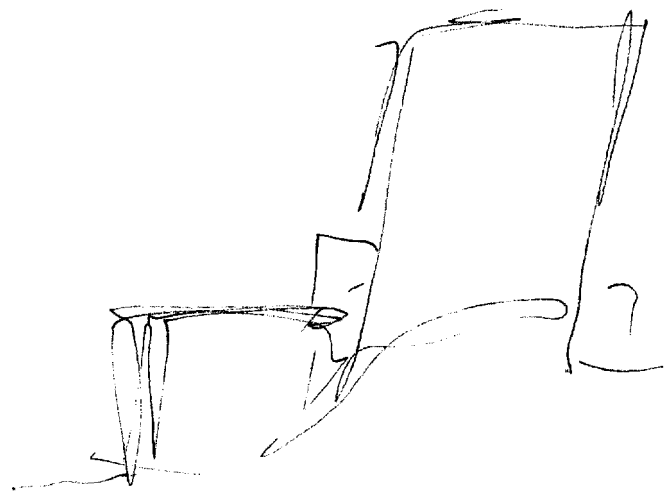

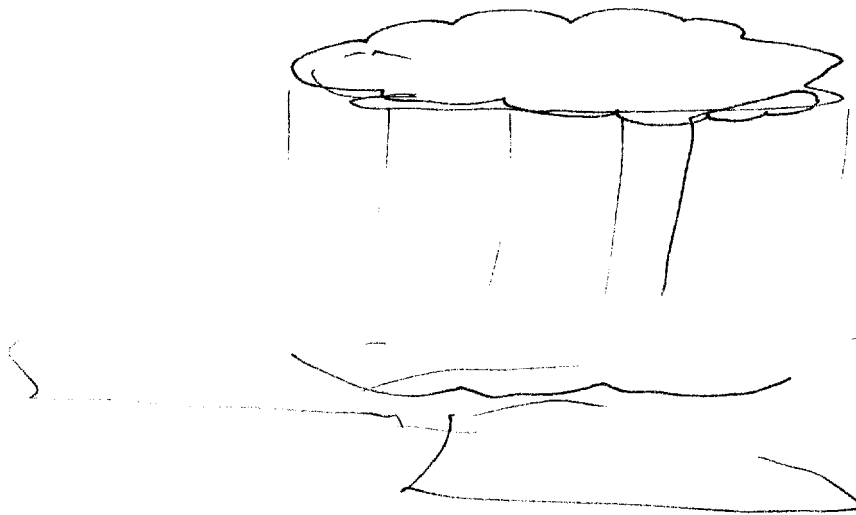
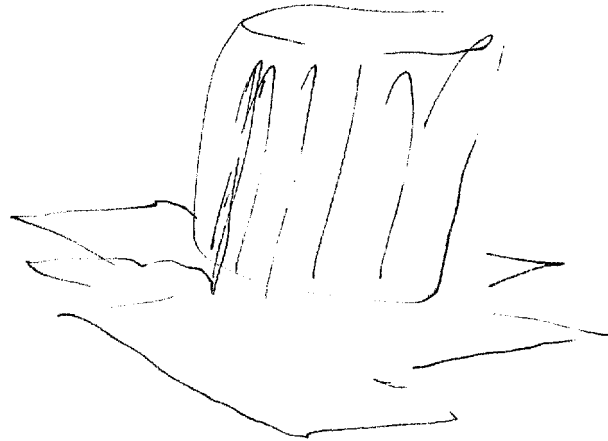



Break

Resume

2530L
318317

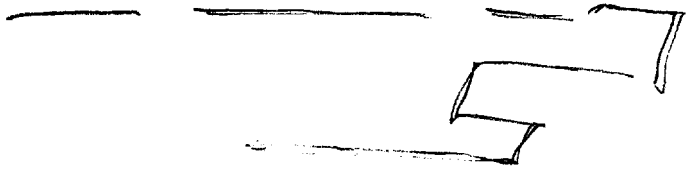

A.
confusing break

82530L
318317

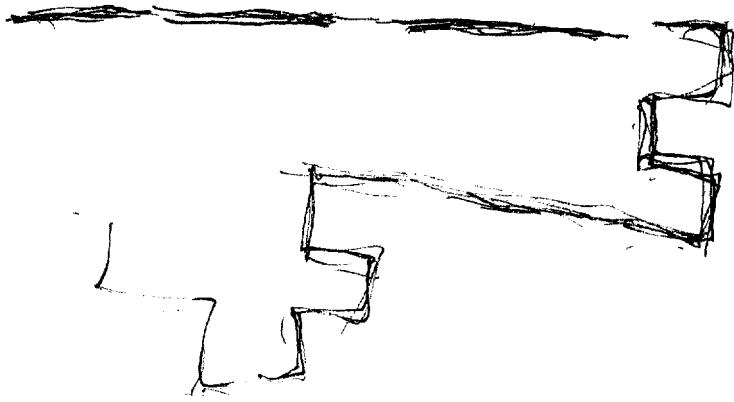

A. across
using
solid

B.

A. along angle
along
solid

B. Structure

A. along
angle

B. Structure

52

white

green

blue

sandy

rough

stained

pitted

long

low

widening

shrinking

angles

going along

with

long

than

As Bk
sandy

A2 Bk
forsaken empty
feeling

large area

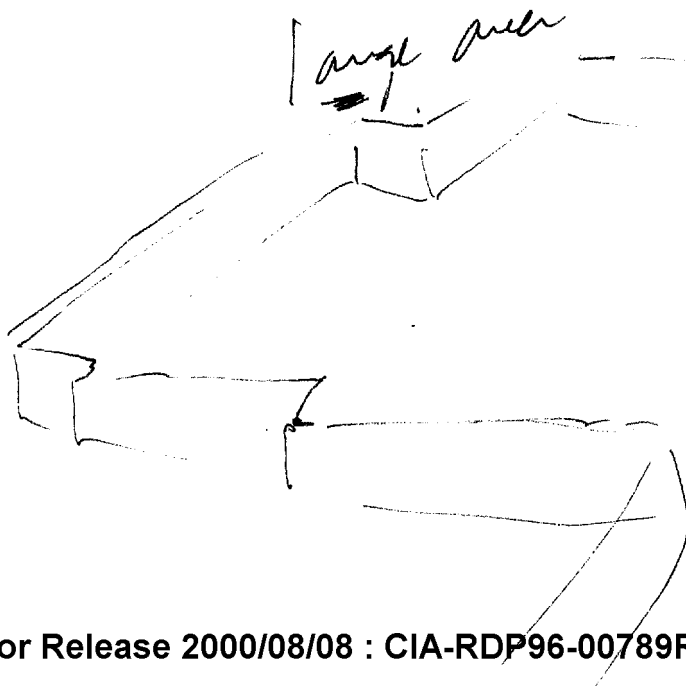

A04 Bk

like a
wall

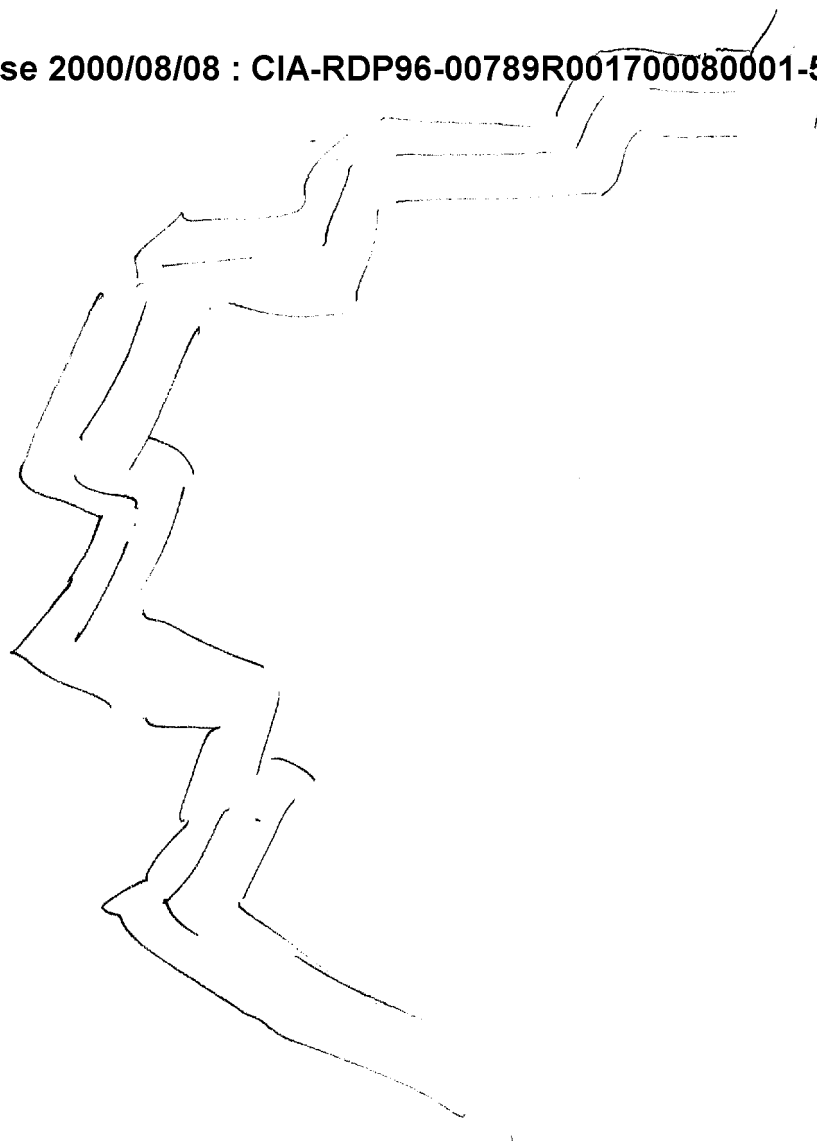

up & down

402 13k

"like undulating"

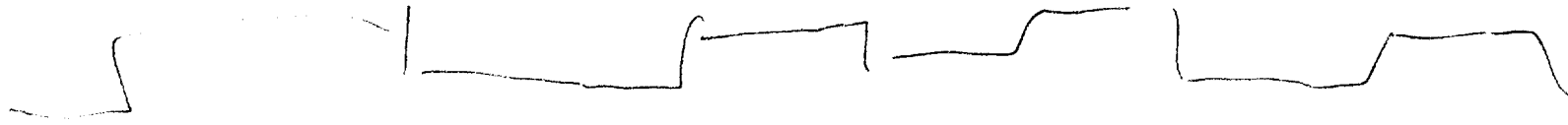
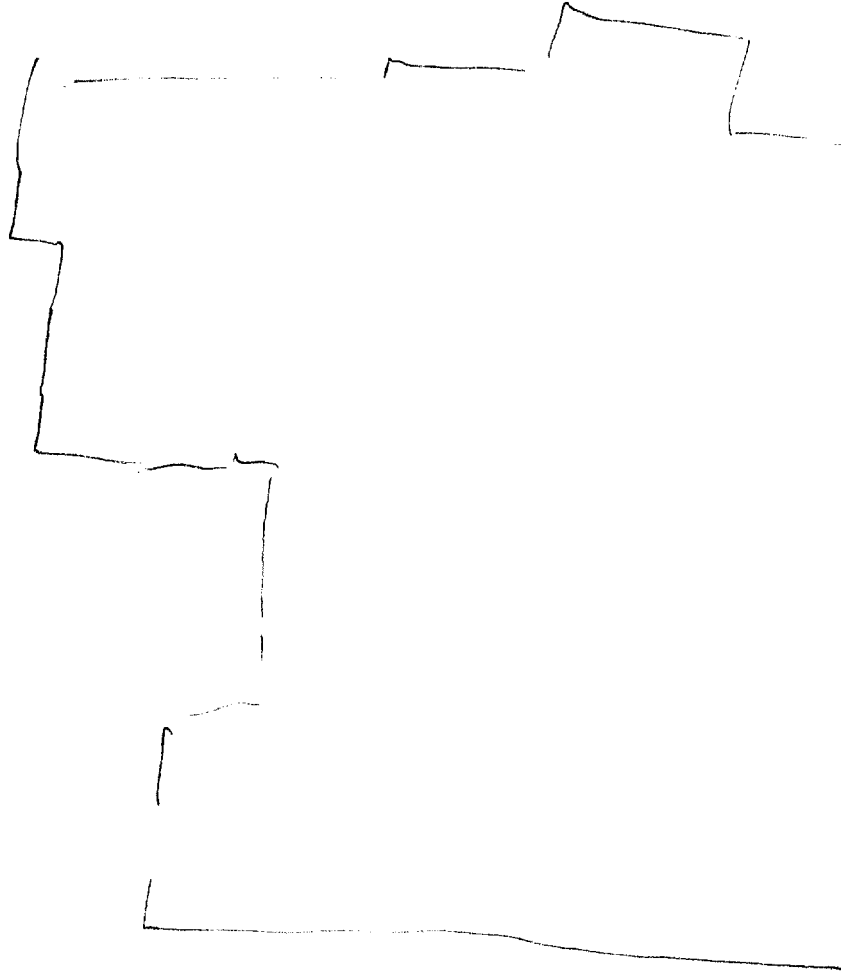

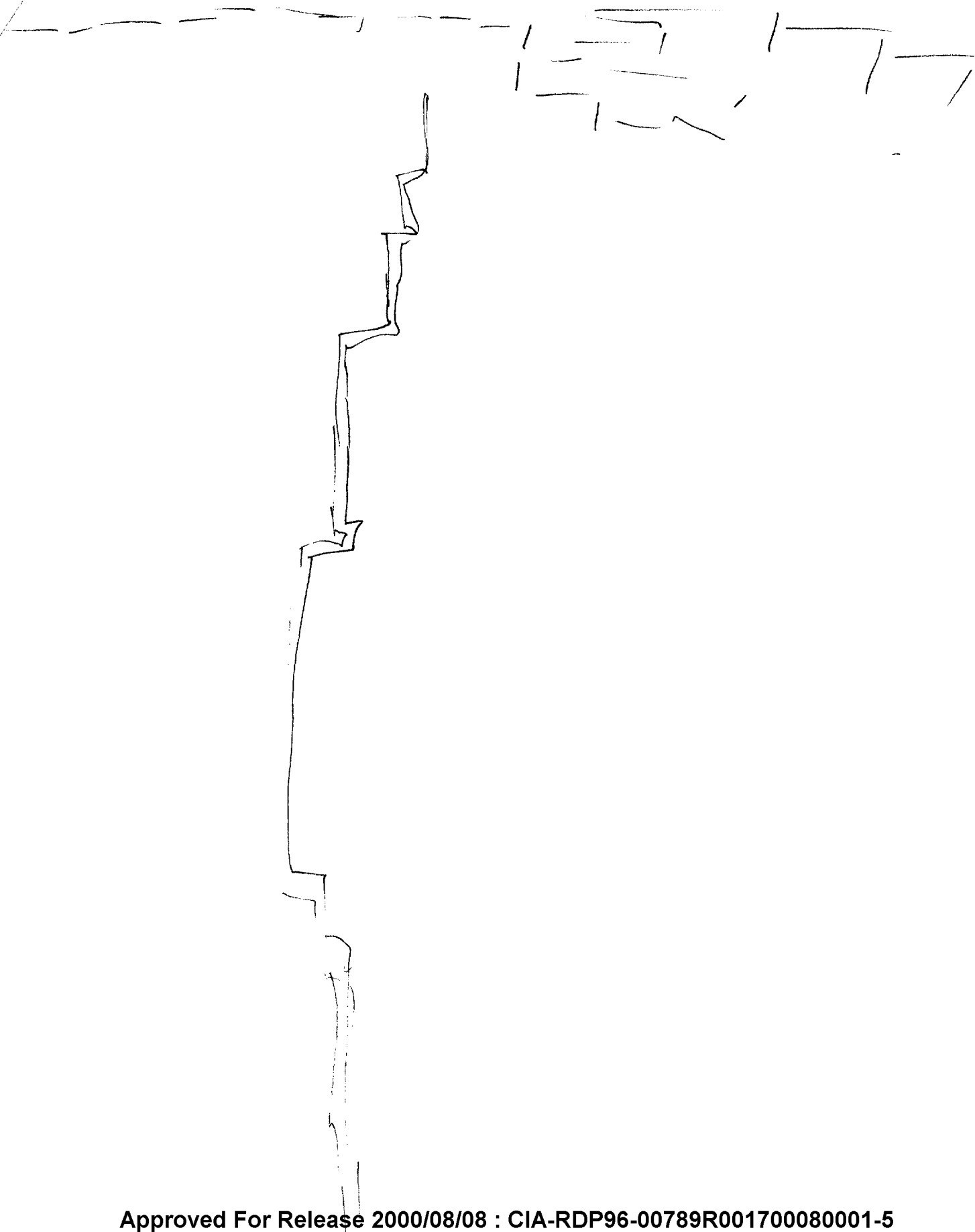

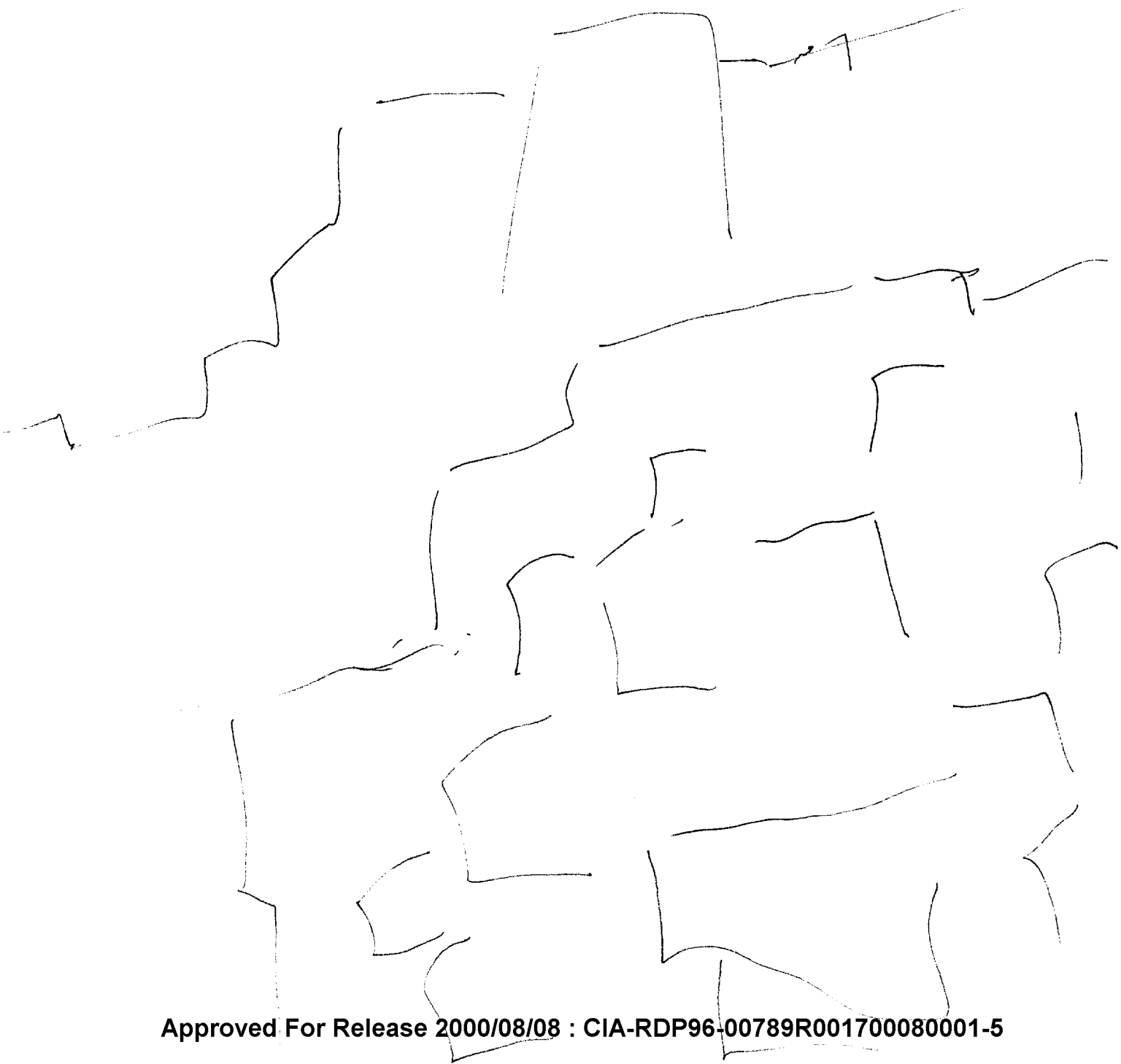



Adl Bk
Medieval
walled city

dark
colored

lighter
colored

Structures at the site & some were made, have many 17
high, so for a long distance, and in several different directions
at different times. ~~(They are low, patterned, straight, curved~~

Site is somewhat of representational pattern covering a
very broad area; with perhaps symbolic and/or decorative
purposes; it is made of lines & strips involving very rough,
rocky textures. Organization & cooperation were intrinsic in
the construction. Site has a very old, perhaps ancient sense about
it. Structures at site represent animals, birds & people.
Purposes are apparently affiliated with cosmology, religion, &
mysticism. Construction involved group dynamics & working
together toward a common goal. (A labor of love, not a labor
of force).

Feedback
Nat. Geos. May 1975 716 ff

5-2

D

AZ

FI

T

I

ACL

AL5

tapered

long
away
angle

rough
smooth

jointed

menen

up + down

reddish

stepped
spread out

green

structure

horizontal

alcove

carved
colars

umber
ochre

masonry

~ ~ ~ ~

A Z B⁺
mystified

AL BK
Nazca Lines

no people
present

dark
doorway

inside

gritty
floor

chambers

chiffered
objects
on floor

stairs

outside

Cool
dim

very
quiet

stale
smell

Sunny

D

AZ

EI

T

I

AOL

A/S

preserved
isolated

Structures

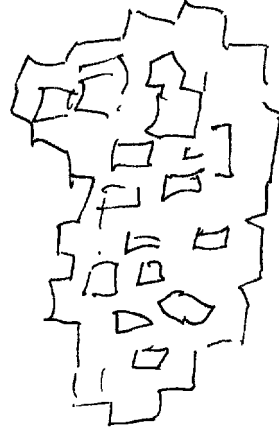

disrepair

weathered

faded
red

Obj, wt



2
bound
D
AZ
EI
T
I
HDL A/S

bound
50 meters

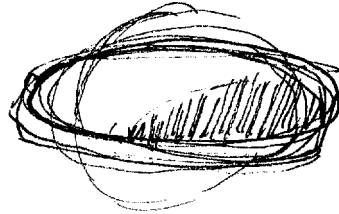

Aoz B k
pueblo
ruins

S VI

2

D

AI

EI

T

I

DOL

A/S

PROL Bk
can Godwin
vains

PROL Bk
fish farm

~~network~~

network

ruins

rough
bumpy

nodes

flat

clattered

pattern

representational

design

path

~~some~~

warmish

bring
of
some sort

form
objects
emanations?
rocks
lines
strips
colors
contrast

Pattern
attributes
emanations?
curved
straight
angular
darkness
lightness
contrast.
flat
low
arranged
large
regular
spread out
natural
Circular

Pattern
Subjects
emanations?
decorative
symbolic
Ancient
monumental

Pattern
Topics
Expansion?
Cooperation
organization
substance

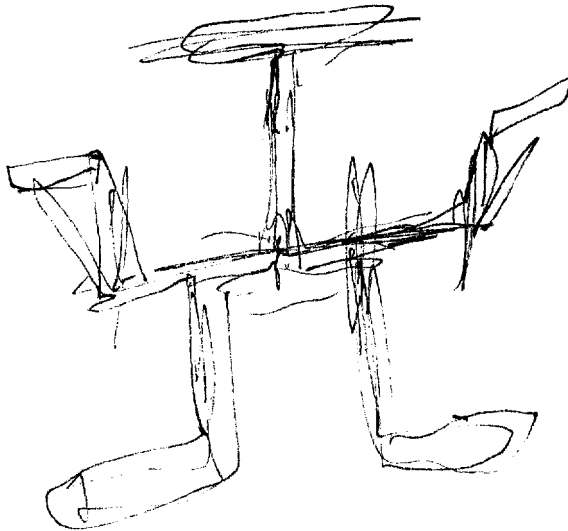
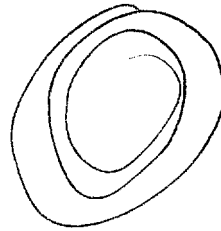

presentational
subjects
emanations ?

lines
patterns
image

representational
attributes
emanations ?

representational
attributes
emanations ?

curving
assembled

representational
subjects
emanations ?

animals
birds
people
children
symbols

consciousness
cosmology
observations
markers

synapse
mysticism
beliefism
accetism
visionary

representational
 topics
 innovation?
 group dynamics
 working together toward
 a common goal
 way marker

End 11:25

Approved

6-00789R001700080001-5

