

*Phase 2*

SESSION SUMMARY

A. SESSION DATA:

Task/Target No. 91-22-0 Source No. 049  
 Date Task Received 9 Dec 91 Date Summary Returned 11 Dec 91  
 Session Date 11 Dec 91  
 Target Designator 716312 Session Start Time 1000  
~~XXXXXXXXXX~~ 588857 Session Stop Time 1110  
 Beacon/Sender No. NA Session No. 01  
 Session Type S Session Method CRV  
 (M)onitored, (S)olo (CRV, ERV, WRV, etc.)  
 Monitor No. (if any) NA Estimate of Outcome M-H  
 (High, Medium, Low)

Possible Session Aids/ Distractions: PI's: back ache; external noises; billet situation  
AV's: male, well dressed; either colorful shirt clothes or surroundings.

B. SESSION SUMMARY: (Below, or see summary and worksheets attached)

*'see attached'*

Summary of Information

The individual is a man with dark hair and dark eyes. His facial features, especially his eyes, have a "weasel" like expression/appearance. He is dressed in dark blue clothing. The general impression is that this person is in, or has been in, an upper floor or level of a relatively tall structure. This location sits high above a sidewalk and/or street. This is the 30th or 33d level or floor of this building. In addition, the number(s) 30 and/or 33 are important to this person. If he has a choice, he will choose one or the other of these numbers.

The terms "lackluster" and "prime" or "primal" are applicable to this individual. He is concerned with "bridging a gap"; that is, he is attempting to "fit" different processes or functions together...a "linkage" as it were. He is sitting at a table looking over a series of large, white papers reminiscent of engineering schematics which are spread out. He is analyzing this problem of "linkage".

The structure is tall and occurs within a dense urban area. However, this urban area is surrounded by a wild or exotic environment. The diversity of fish and game species which are present is, for some reason, important. A line of mountains can be seen in the distance. This building occurs within an area of an conglomerate of angles, lines, squares and movement. A river divides this area of confusion. I want to say South America and specifically Brazil, but something isn't correct about this guess.

Nearby are flat sheets which glimmer as if a curtain of water is flowing over a monumental-sized piece of glass. There is a grinding noise and construction nearby as well.

For whatever reason, "shoes" are significant to something or someone.

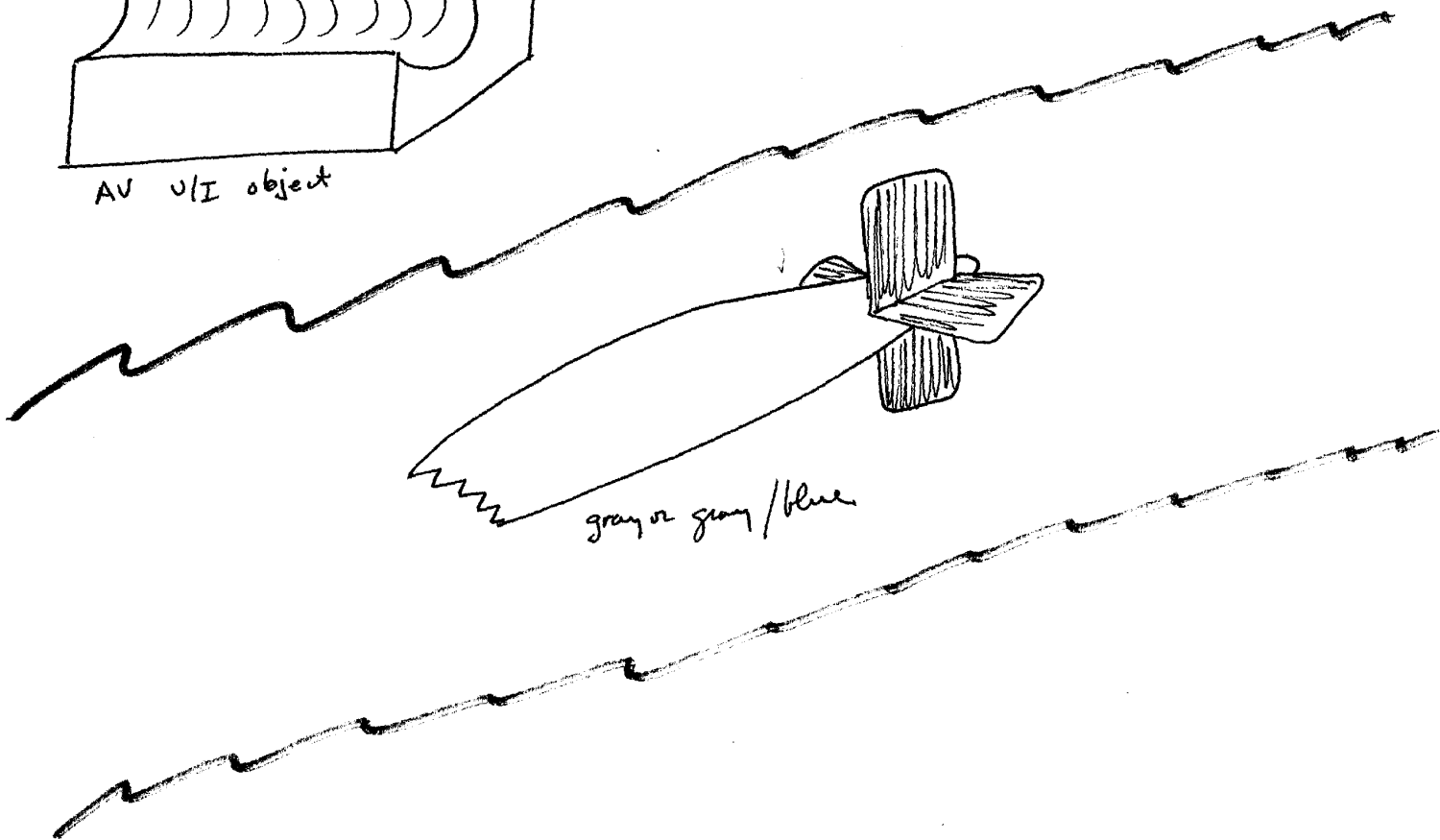
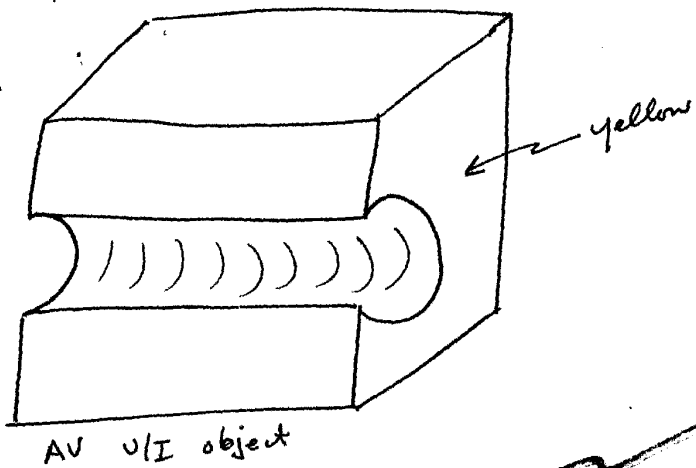

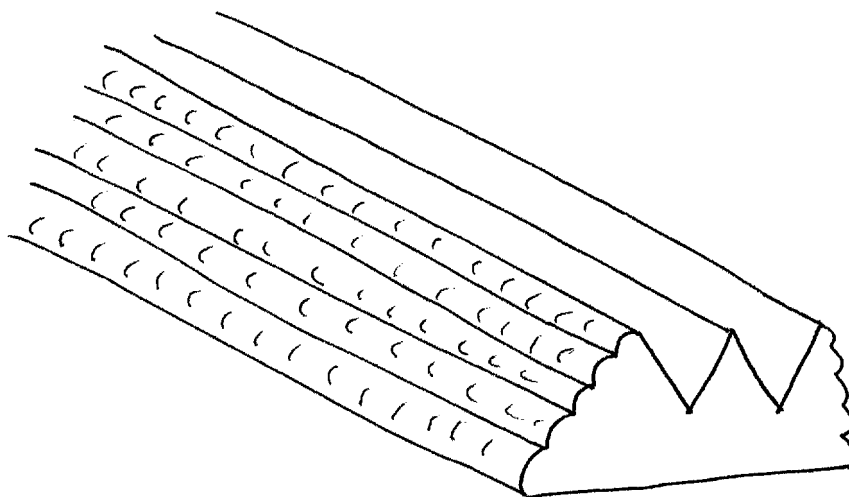
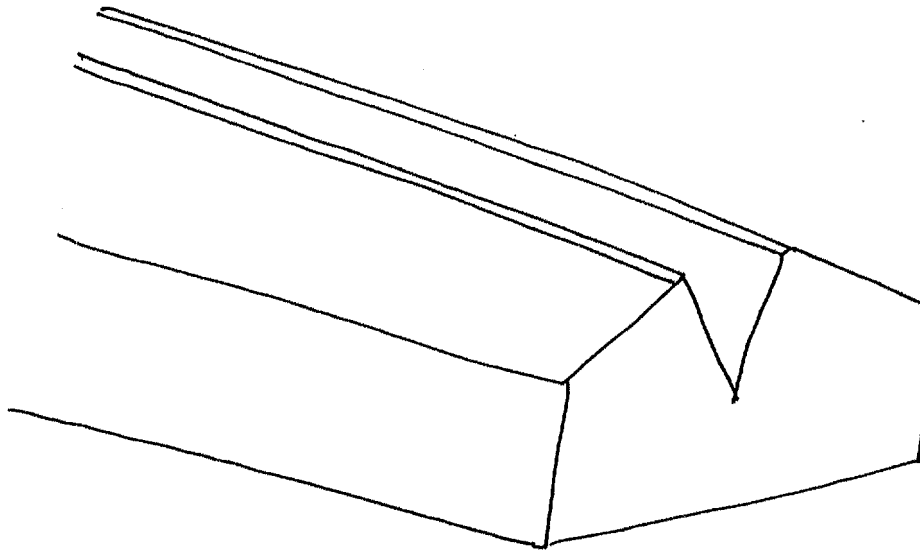

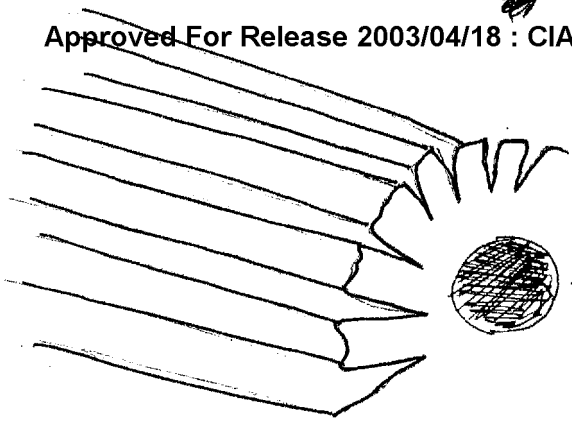

very dark or black;  
not hollow but recessed  
from end

x Has cracked or deteriorating  
edges. just part of this object  
has a metallic feel.

energy or electricity

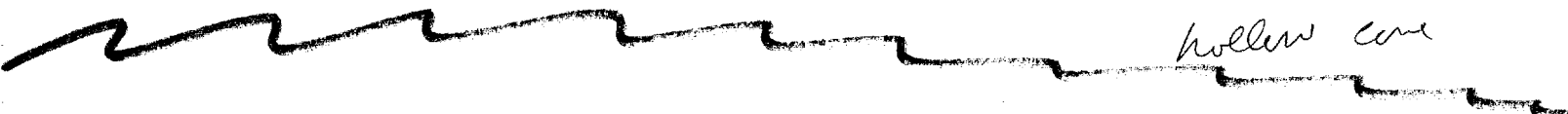

hollow core

This surface has a  
brushed appearance

52

angles  
double "L" shaped lines

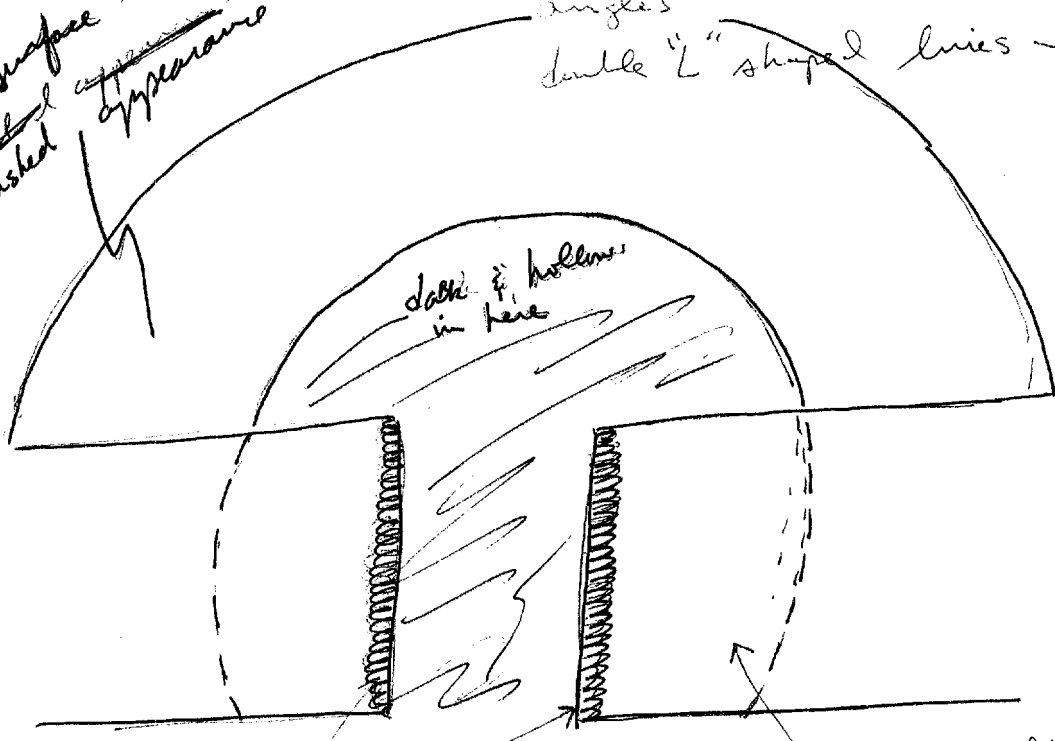

double "L" hollow  
in here



PI BK

Damn fine sieves

Tightly  
coiled features  
on either side

Roundness of hollow contains  
behind this wall / barrier

-- SIDE VIEW

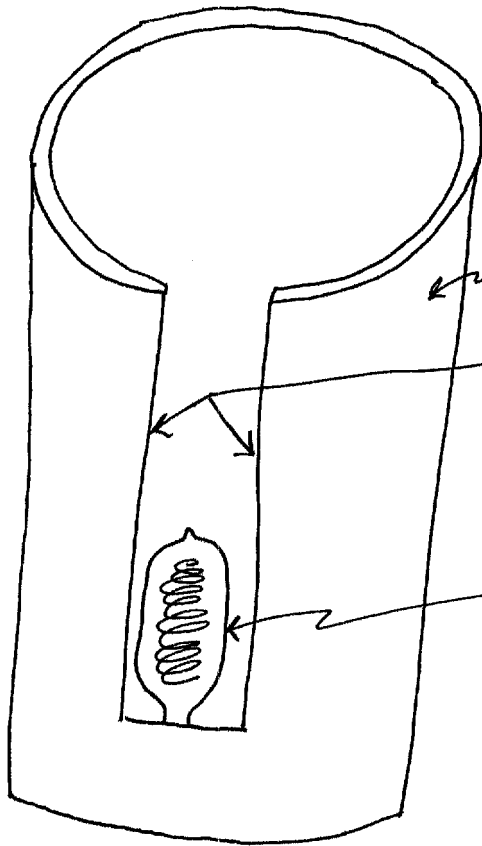

metal casing

"Slot" or opening runs most of the height of this object

Shiny, "glassy" object w/ spirally material in side of it. This object sets on a raised section in the center of the metal casing part.

- OVERHEAD VIEW -

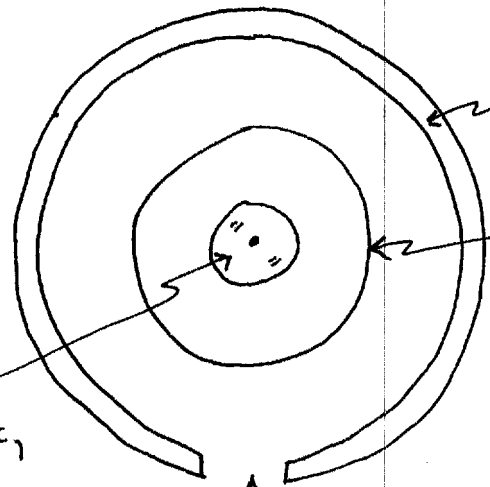

metal casing

raised section

Shiny, "glassy" object w/ spirally inside

opening

PI - back aches, extreme noise, uncertainty of bullets here, etc.

AV - male; well dressed, with colorful clothes in surroundings.

049  
Ft Meade  
11 Dec 91  
P: 91-22-0  
S: 01  
ST: ~~0930~~  
7000  
ET: 1110

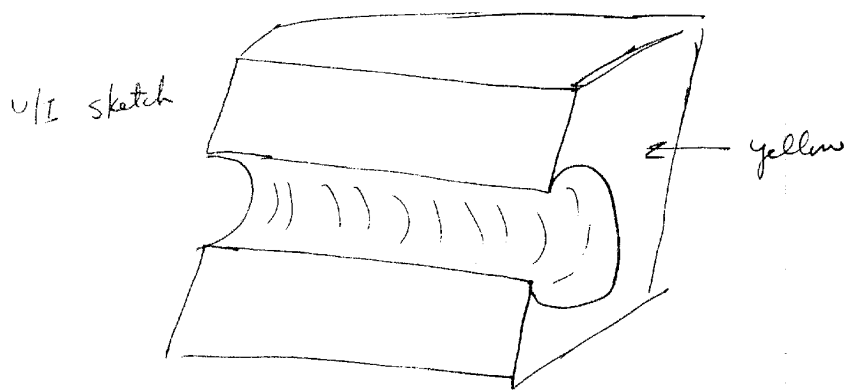

716312 588857

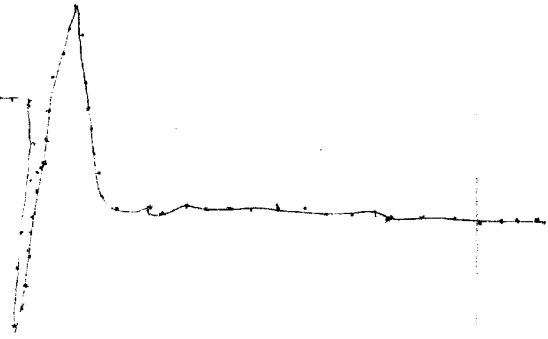

A - across, angle down, a few, sharp angle down, some faint, slightly wavy line across.

- hard mammals

B. structure

MSL  
Dach automobile

A - hard mammals

B - structure

MSL  
Side of full barrel; pent house, etc.

3)

A/S

Dark blue clothing  
~~or~~  
black

AOL

Top Iraqi nuclear  
weapons scientist  
(the dickhead who  
confronted the UN  
inspection team).

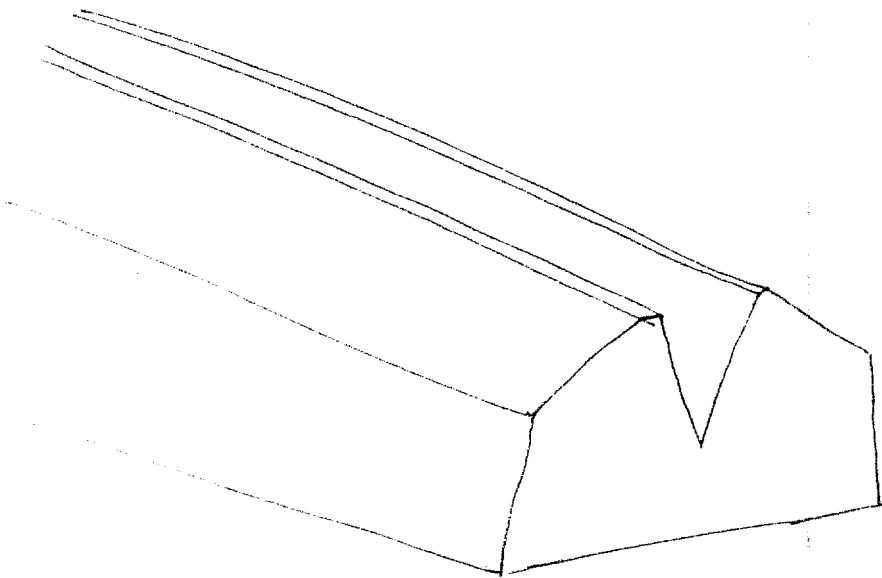

U/I figure

white socks

AOL

Scene of dismantled  
Iraqi refining  
equipment



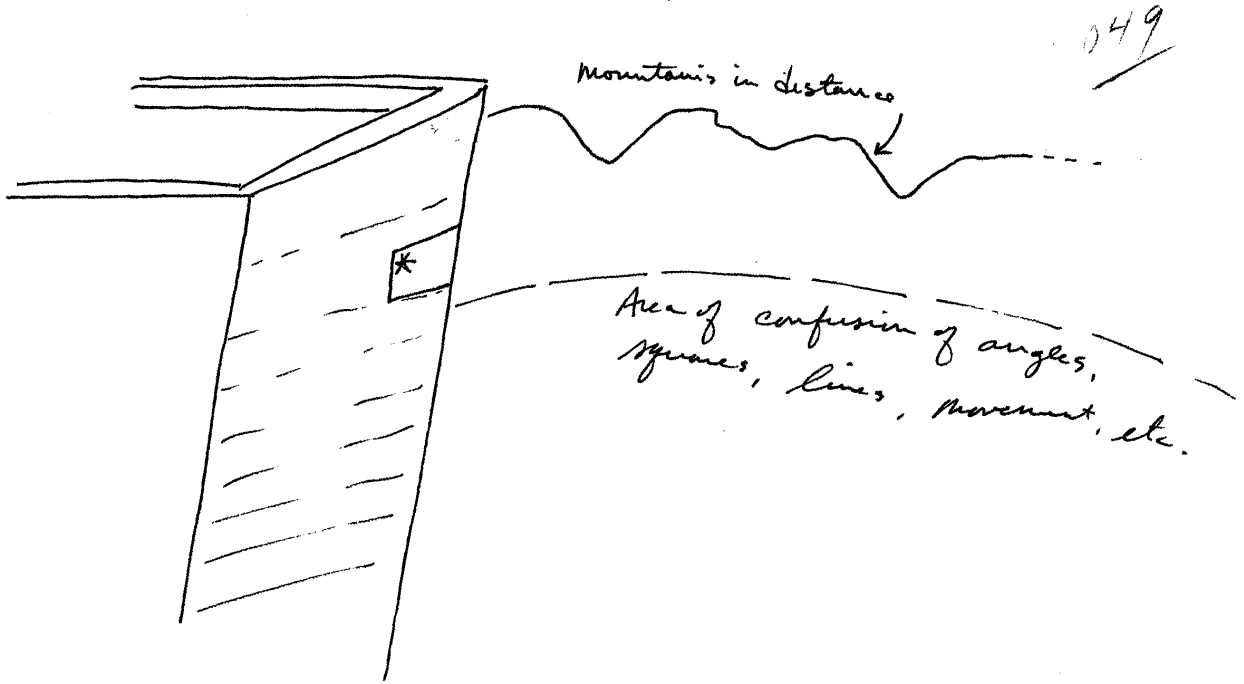

\* 30th or 33d floor or level of structure

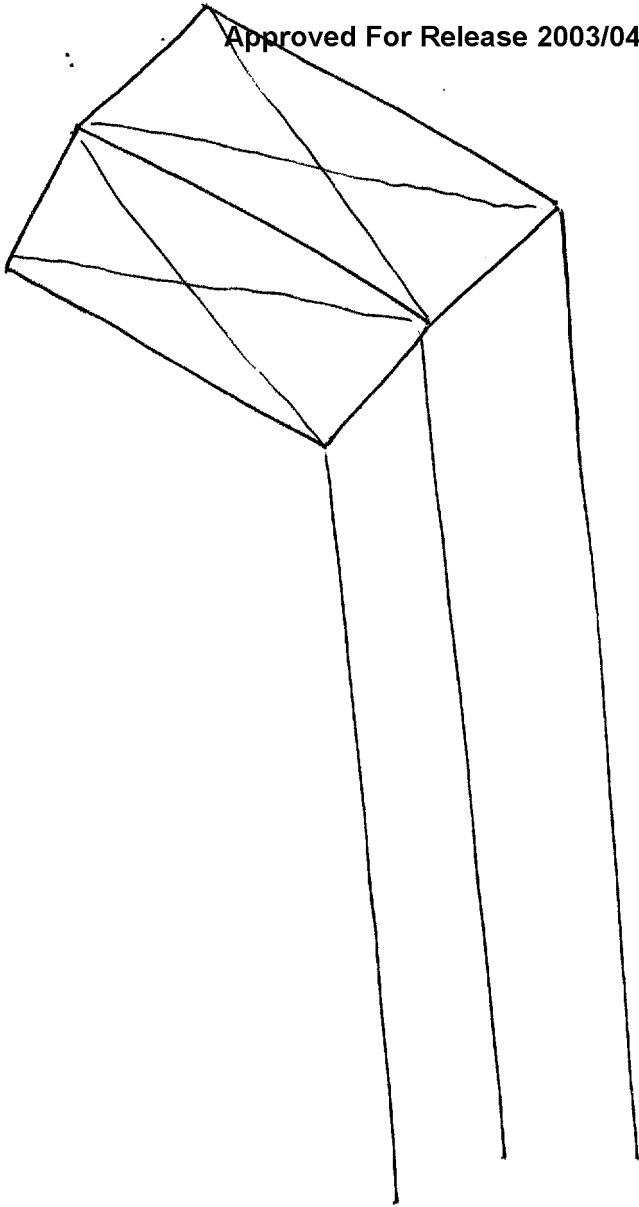

Large, enclosed "chute"  
or "duct"; spinning gear.  
Size dwarfs a human being

Concepts:

Dusty; processing;  
milling; Refining, etc.



Conically-shaped object; a stream of  
something (a beam of light or energy)  
randomly bounces around inside of  
this, striking the bottom surface. Rapid  
movement; gives one the sense of a  
"dancing" neon light. Very  
hazardous.

yellow

stripes or ribs

angles

crooked or deteriorated edges

metallic feel

just part of it.

black lines or bars

cites  
squares  
round  
spherical  
wavy lines

connect

↳ bridging a "gap"

[Describe personality "A"]

lock luster

prime or primal

lots of angles

AOC  
Abstract art

Dark hair

Dark eyes

Wear a like expression

AOC  
Give me a break

7)

AI

EI

T

I

AOL

A/S

[A's circuit ~~mess~~   
 activator]

sitting at table

white paper spread out  
analyzing

Engineering A/S  
Schematics for

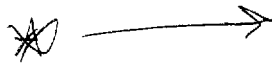

attempting to "fit"  
different things together

\* like processes or  
functions

linkage

- Side view -

AOL

Nucleus crop

- overhead view -

metal casing

slot or opening  
was most of the  
width of the object

shiny, "glassy" object  
w/ spirals, in hole of  
it sets on a raised  
section right in the  
center of the case  
part

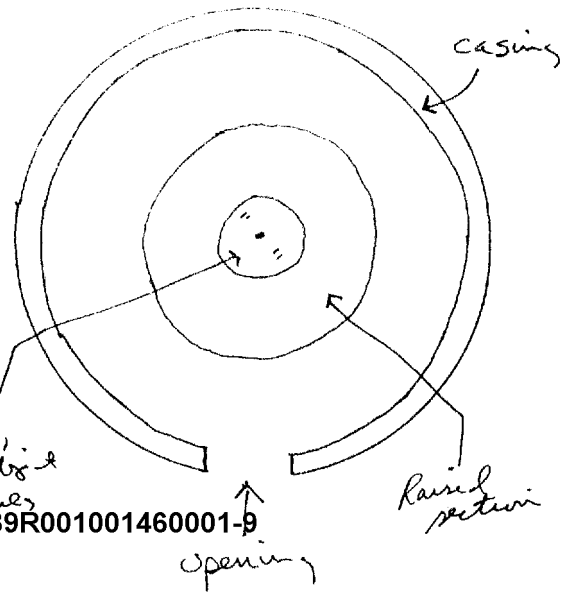
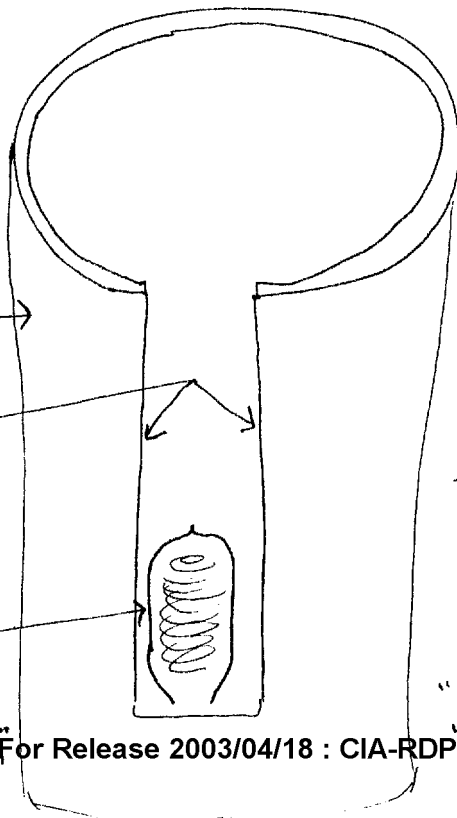

shiny, "glassy" object  
w/ spirals  
inside

raised section

opening

AOL A/S

BK 1041  
1050

[A's Surroundings]

54/2 <sup>A/S</sup> Tall build; w/i a highly dense urban area; but urban area is surrounded by wild or exotic environment. I want to say S.A., Brazil, but something isn't correct.

to the 30 or 33rd floor of this building

why? → jungle; construction; fish; game important species diversity

urban in distance

AOL  
Amazonia

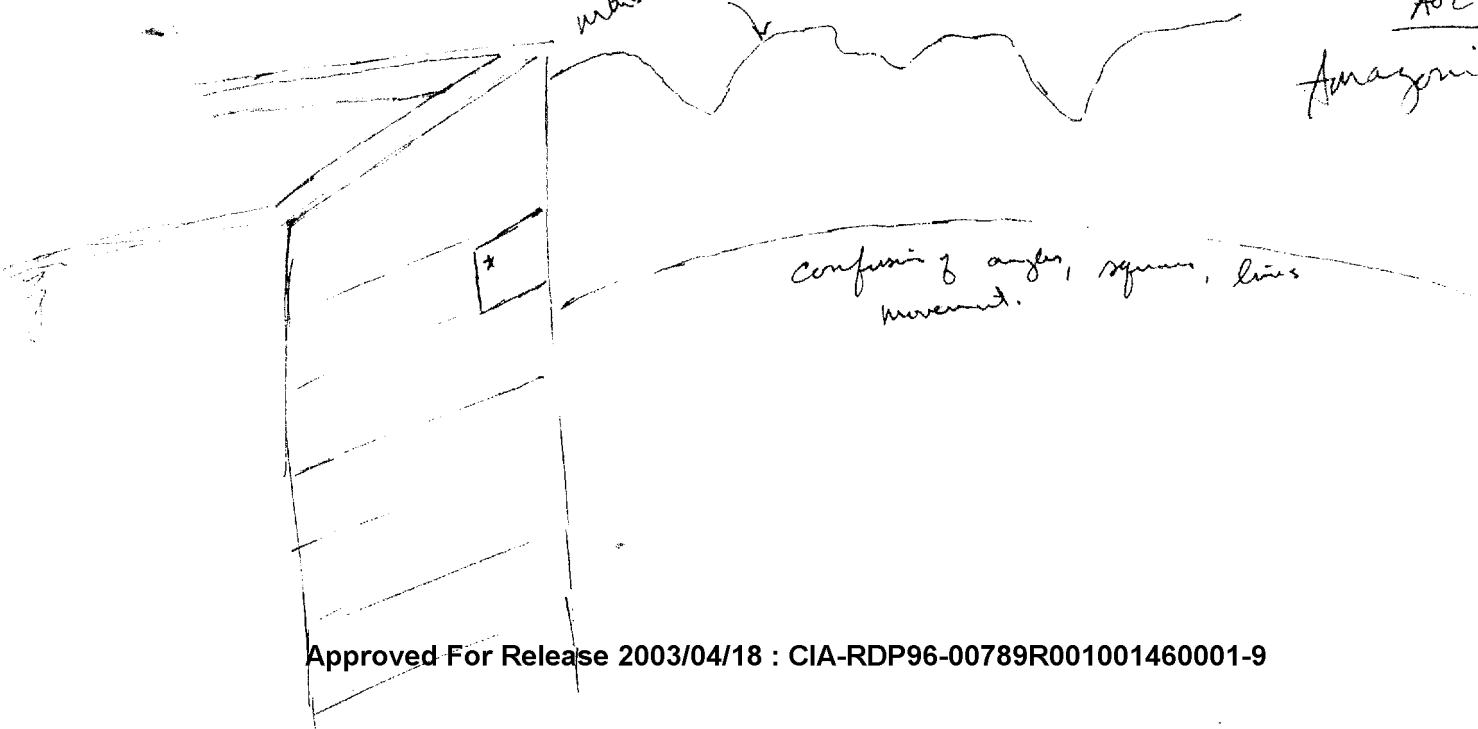

a)

541/2

The #(s) 30 & 33 are important to this person; if he has a choice, he will choose one or the other.

[A's swimming] #

glimmering, flat sheets,  
like a curtain of  
water flowing over  
the a monumental  
piece of glass.

River divides confusi

A/S  
Large Brazilian  
city along  
river.

shoes feel significant

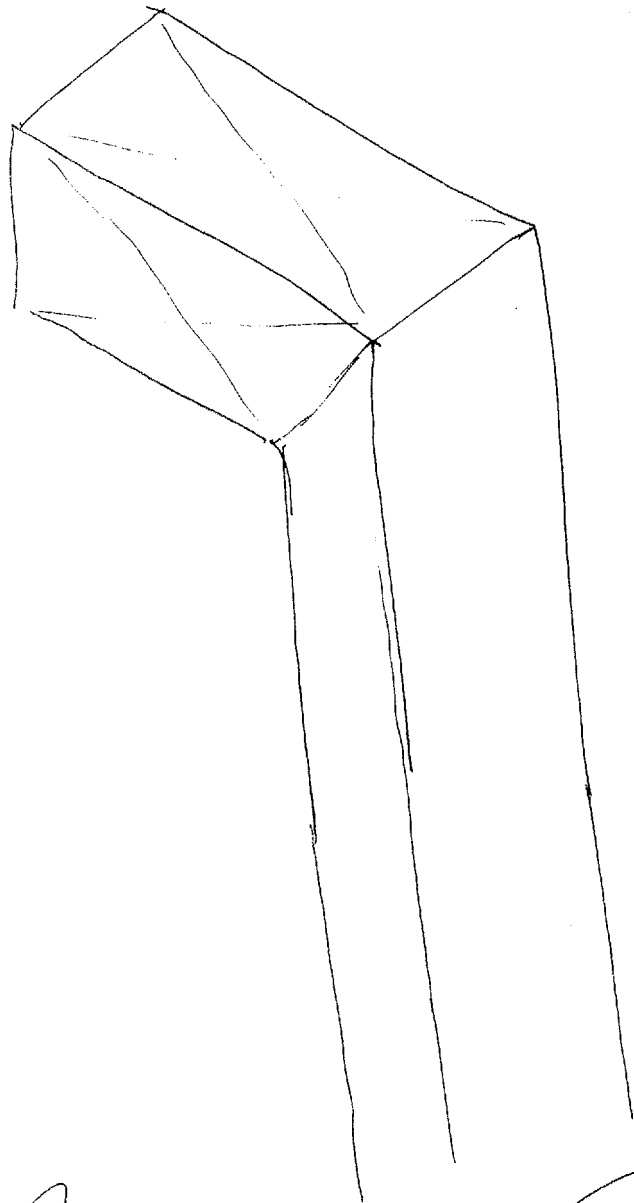

large enclosed  
"chute" or duct; shiny  
gray. Dwarfs a  
human being.

Dusty; processing,  
milling, refining, etc



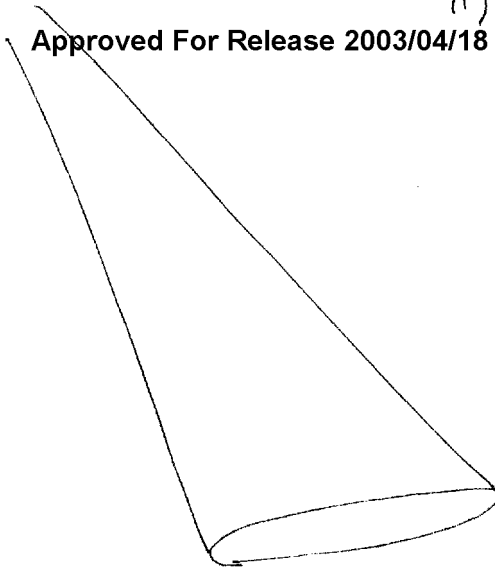

\* Conically shaped object;  
a stream of something;  
(a beam of light or energy)  
randomly bounces around  
inside of this, striking the  
bottom surface. Rapid  
movement; gives me the  
sense of a "dancing"  
neon light. Very  
hazardous.

ET  
1110



*Phase I*

SESSION TASKING SHEET

Source No. 049

Date Task Initiated 9 DEC '91

Suspense Date COB 11 DEC '91

Task/Targeting No.: 91-22-0

~~Method~~ Method/Technique: Method of choice.

Target Data Desired:

1. DESCRIBE KEY TARGET FEATURES (include forms, shapes, spatial aspects, color, motion/dynamics):

- Emphasize the following: \_\_\_\_\_
- Do the following perspectives:
  - Ground-level
  - Overview
  - Other: \_\_\_\_\_

2. IDENTIFY KEY TARGET CONTENT (include meaning, purpose, function, nature of activity, type/nature of people, if present):

- Emphasize the following: \_\_\_\_\_



\*

3. IF PERSONALITY, ~~IDENTIFY~~:

- Describe personality identified as TARGET "A."

~~4. ENVIRONMENT (if needed)~~

- Describe A's surroundings.  
- Describe A's current activities.

5. ADDITIONAL GUIDANCE: (see attached)

- This is an operational project.  
- Optional coordinates: 716312/588857

A - soft water  
B - water

~~Are~~ A/S  
Waves crashing along a breakwater

Trees  
Ridge line

AVC ✓  
Cedars of Lebanon

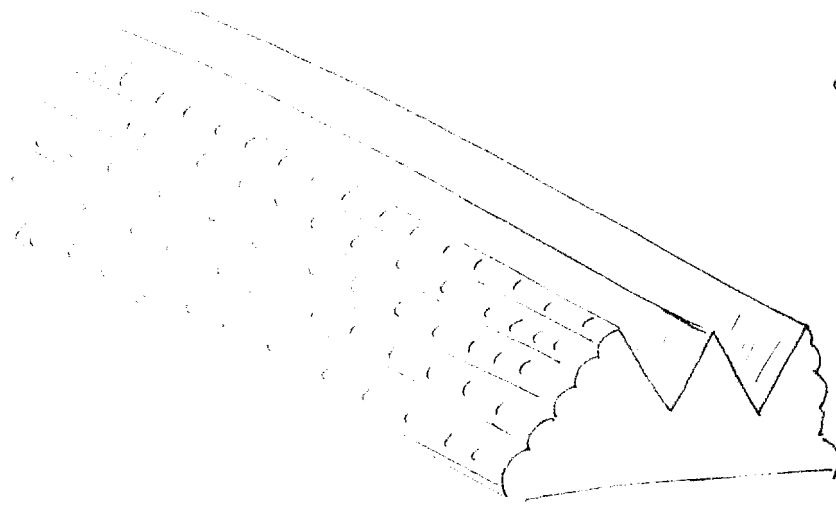

A - flat open smooth  
B - water

PI/AI  
Stomach is growling - loudly!

A - smooth dusty hot  
B - land

AVC  
Desert settle,

5)

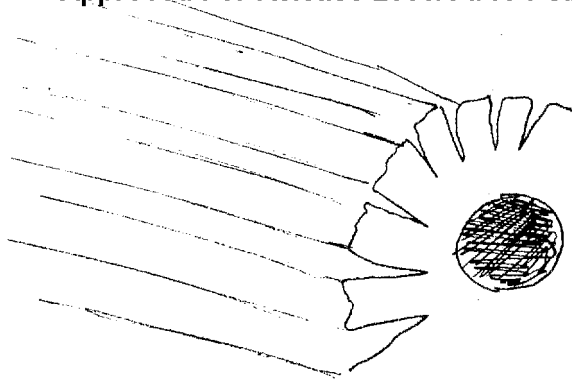

very dark or black;  
not hollow but recessed  
from end

energy or electricity  
hollow core

This surface has a  
brushed appearance

S2  
angles  
double "L" shaped slices

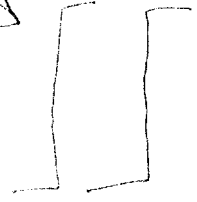
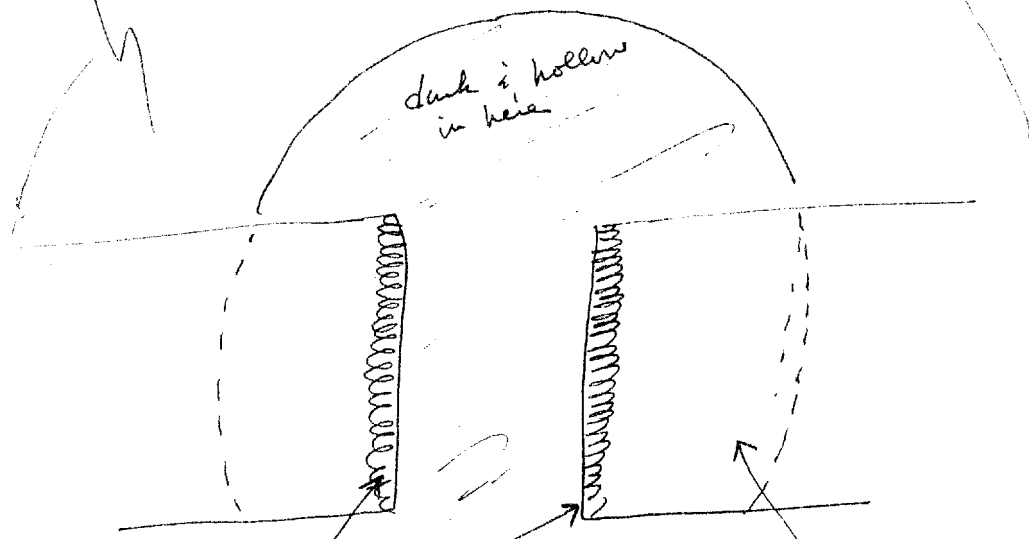

PE BK  
Damm fire screens

Tightly  
coiled features  
on either side

Roundness of hollow continues  
behind this wall / barrier

92 .D AI EI T I AOL A/S

5/12 My feeling is is that this person is somewhere around ~~is somewhat obscure~~ but not w/ the Middle East people.

[Location of Target]  
[Surrounding]



gold or brass  
bronze

lots of brass rings

AOL  
Neck decorations  
of some African  
groups

3)

52

D.

AI

EI

T

I

AOL

A/S

[Summery of Target]

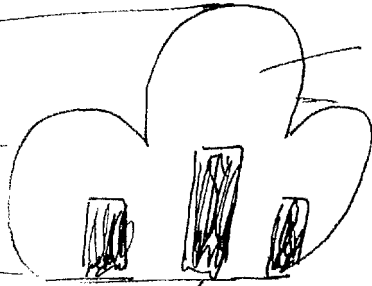

gray stone or concrete  
part of a structure

three  
"openings"

large face in profile

A/S  
Sphinx

AOL  
Egypt

door knob  
hallway  
window

[Look outside. windows - describe]

hot  
yellowish air  
stench of street smells

[what kind of smells?]

- sharp, acidic smell like urine
- rotten organic
- sharp, chemical smell

A/S  
solvent

52

D

AI

EI

T

I

A/C A/S

leather

A/C  
Tel Aviv  
old Joppa

smell of water, like  
the breeze off of a large  
body of water

A/S

Khartoum,  
Sudan

- a smell like crushed  
nuts or seeds
- not peanut butter,  
but similar

A/S

Sesami seed  
butter

54 1/2

The surrounding "wilderness" abruptly  
comes to meet the edge of the city  
on one side. It's as if the natural  
environment is "sweeping" & encroaching  
upon the side of the city. Looking out  
of the window, this is on the left.

52

D

AI

EI

T I AOC AS

AT

This is all garbage

546. This place feels third world, middle  
east like, but it isn't the Middle East.  
I want to go south.

Any time.

Vicinity? Kampala Uganda

ET 0940