

[REDACTED]

[REDACTED]

Classification Cancelled

or changed to

UNCLASSIFIED

AUTHORITY *automatic*

H. Hough

4-12-63

FOR OFFICIAL USE ONLY

U.S. AIR FORCE

Project

RAND

**INQUIRY INTO THE FEASIBILITY OF WEATHER
RECONNAISSANCE FROM A
SATELLITE VEHICLE**

April, 1951

R-218

REPRODUCIBLE COPY

4 - DOWNGRADED AT 2 YEAR INTERVALS
DECLASSIFIED AFTER 12 YEARS.
DOD USE ONLY

The RAND Corporation

1500 FOURTH ST. • SANTA MONICA • CALIFORNIA

[REDACTED]

[REDACTED]

PROJECT RAND

(USAF PROJECT RR 1)

INQUIRY INTO THE FEASIBILITY OF WEATHER RECONNAISSANCE FROM A SATELLITE VEHICLE

S. M. Greenfield and W. W. Kellogg

April, 1951

R-218

FOR OFFICIAL USE ONLY

The **RAND** Corporation
1500 FOURTH ST. • SANTA MONICA • CALIFORNIA

CONTENTS

SUMMARY	v
INTRODUCTION	1
THE SATELLITE VEHICLE	2
WHAT CAN BE SEEN	3
Area Coverage	3
Resolution and Limiting Contrasts	8
LIMITATIONS OF THE ANALYSIS	13
WHAT CAN BE DETERMINED FROM HIGH-ALTITUDE OBSERVATIONS	14
Cloud Identification	14
The Analysis	15
SUGGESTED METHODS OF ATTACK ON THE PROBLEM	
OF DETERMINING THE SYNOPTIC SITUATION	22
RESULTS OF THREE ATTEMPTS AT ANALYSIS	24
Viking No. 3 (NRL)	24
V-2 No. 28 (AFCRL)	27
Aerobee A-7 and V-2 No. 40	27
Comments on the Preceding Analyses	30
CONCLUSION	31
APPENDIXES	
I. DETAILED ANALYSIS OF SYNOPTIC WEATHER AS OBSERVED	
FROM PHOTOGRAPHS TAKEN ON TWO ROCKET FLIGHTS	
OVER WHITE SANDS, NEW MEXICO, JULY 26, 1948.....	33
II. FILMS AVAILABLE FOR THIS STUDY.....	43

FIGURES

1. Viewing system	3
2. Available contrast with varying cloud and background albedos	11
3. Vertical wind shear—temperature gradient relationship	18
4. Graphical representation of degrees of stability as given by lapse rate of temperature	19
5. Schematic representation of viewing area from rocket camera	25
6. Synoptic situation as estimated from Viking No. 3 photographs, February 9, 1950	26
7. Actual weather situation from weather map for February 9, 1950, 1330 EST..	26
8. Estimated synoptic situation from V-2 No. 28, December 8, 1947	28
9. Actual synoptic situation from surface map for December 8, 1947, 1330 EST..	28
10. Estimated synoptic picture from V-2 No. 40 and Aerobee A-7, July 26, 1948.	30
11. Surface weather map for July 26, 1948, 1130 MST.....	33
12. Selected upper-air wind maps	35
13. Composite photographs taken from V-2 and Aerobee rocket flights on July 26, 1948	36
14. Profile along 32°N	38

TABLES

1. Resolution of clouds by sunlight	4
2. Resolution of clouds by second- and third-quarter moonlight	5
3. Resolution of clouds by light of the night sky	5
4. Possible performance capabilities for various image orthicon cameras, taking into account illumination sources	6
5. Surface albedo and scene contrast of clouds against various background surfaces	12

SUMMARY

It is assumed that, in the event of armed conflict, aerial weather reconnaissance over enemy territory, similar to that obtained in World War II, will be extremely difficult if not impossible. An alternative method of obtaining this information, however, is thought to lie in the use of the proposed satellite vehicle. It is obvious that any meteorological reconnaissance utilizing only observations from such a high-altitude "eye" cannot provide quantitative values for the parameters normally associated with standard weather observation and forecasting techniques. In determining the feasibility of such a system, therefore, the questions that must be answered are: (1) What extent of coverage can be expected from a satellite viewing system? (2) In terms of resolution and contrast, what can be seen from the satellite? (3) Given proper coverage and resolution, what can actually be determined regarding the synoptic weather situation from this information?

A current technical report on the satellite¹ proposes several possible flight altitudes between 350 and 500 mi. For the purpose of the present study, however, only the 350-mi altitude was considered to any extent. At this altitude, a vehicle would have an orbital velocity of about 24,870 ft/sec and would make one complete circuit of its orbit in 1.6 hr. Assuming that any regressive motion of the satellite's orbit owing to the spatial motion and oblate shape of the earth is corrected for, and that the area it is desired to observe is in daylight during the vehicle passage for an extended period, this area will be covered and televised in a grid fashion once every 24 hr. It is visualized that, by means of mechanical scanning transverse to the path of the satellite, a continuous strip whose width is equal in order of magnitude to the altitude of the vehicle will be viewed. Utilizing a map of Russia with projections of trajectories for a satellite at 354.6 mi and 453.3 mi altitude, direct measurements were made of the area covered by different strip widths. An area of 105,000 sq mi between latitude 45° and 50°N was used. It was found that in the case of the 354.6-mi satellite, one-third of this area was covered grid fashion by a 100-mi-wide strip in 24 hr, and two-thirds of this area was covered grid fashion by a 100-mi-wide strip in 48 hr by the 453.3-mi satellite. Both cases naturally indicated some overlapping, which increased as the original tangent latitude was approached.

Utilizing photographs from recent vertically fired rockets (V-2), an estimate of the dimensions of the smallest increment necessary for proper cloud identification was made. This was found to be approximately 500 ft and is termed the "usable resolution" in this report. Entering Tables 1, 2, and 3, which give resolution versus contrast for various values of frame speed, aperture size, and various types of illumination, showed that it was possible to obtain this value of resolution in sunlight illumination with contrast

¹ R. M. Salter and J. E. Lipp, *A Satellite Rocket for Reconnaissance*, Project RAND, The RAND Corporation, Report R-217, April, 1951 (Secret).

between cloud and background of less than 10 per cent. An examination of the albedos from typical background objects, as presented in Fig. 2, page 11, compared with cloud albedos seems to indicate that 10 per cent contrast is available over a wide range of possible cloud-ground and cloud-cloud combinations. This, therefore, appears to establish the feasibility of cloud identification from high altitudes, at least from the standpoint of contrast and resolution.

Owing to the lack of quantitative measurements, the clouds must be utilized to their utmost in determining the synoptic weather picture. Experience and statistical climatological values play their part in forming this picture, and the process involves a "hunting technique" that oscillates between the three main tools at the analyst's command. Some detailed estimates of various parameters are possible from the visual cloud characteristics. Items, such as moisture content, temperature gradient, stability, magnitude or direction of vertical pressure gradient, wind shear, and wind direction all show promise of yielding good estimates of the actual values to this type of analysis and of helping to clarify the final estimated synoptic picture. For any future operational use, this study has shown that such things as a cloud atlas of clouds viewed from above, complete climatological material on the area in question (including a possible statistical survey of fluctuations from the normal of the various parameters as attributed to synoptic systems and broken down into small regions of similar climate and topography), and perimeter weather will immeasurably help the job of the observer and analyst. As an aid to getting a "feel" for the problem involved, photographs from three rocket flights were analyzed and the synoptic situation was estimated. These results and the actual weather for the corresponding times are presented in the section entitled "Results of Three Attempts at Analysis," page 24. In an attempt to correlate further the rocket photographs with the actual synoptic picture, Dr. J. Bjerknes, of U.C.L.A., independently made an analysis of photographs taken on a flight on July 26, 1948. In this analysis, all other synoptic meteorological data available for that date were utilized. The results of this analysis are presented in Appendix I.

R-218
v-a

SUMMARY

The value of observing the weather over inaccessible areas by aerial weather reconnaissance has been recognized for many years. An alternative method of obtaining broad coverage of the weather, however, is thought to lie in the use of a special satellite vehicle which could observe cloud patterns. It is obvious that

General considerations of ease of satellite launching and photographic coverage suggest an orbiting altitude of 350 to 500 mi.¹ For the purpose

..... viewed. As an example of the sort of coverage which could be provided at middle latitudes, with a satellite at 354.6 mi altitude the fraction of the area between 45° and 50° latitude which can be covered grid-fashion with a 100 mi wide scanning path in 24 hours is one-third, and if the width of the path is increased to 450 mi the 24 hours coverage is complete.

¹For more concerning problems of satellite operation, reference is made to R. M. Salter and J. E. Lipp, Project RAND R-217 (classified), The RAND Corporation, April, 1951.

INTRODUCTION

In the event of armed conflict there will be large regions of the world from which it will be impossible to obtain weather information by normal means. Owing to the fact that the success of any aerial reconnaissance depends, to a large extent, on a knowledge of the weather conditions over the target, the lack of this information will be felt more and more as any planned air offensive progresses. Systematic weather reconnaissance by some unconventional means must therefore be undertaken.

Although weather reconnaissance by means of aircraft is now a routine matter, wartime defensive measures installed by the enemy might seriously curtail the successful completion of this type of mission over hostile territory. A further solution to this problem, however, consists in weather observations made by means of a television camera placed in an unmanned vehicle flying above the normal range of defense weapons. Such a method has the double advantage of providing both a means of observation having a high degree of safety and reasonable probability of success and an over-all picture of the wide-scale weather situation that is lacking in normal daily station weather observations.

It is obvious that in observing the weather through the "eye" of a high-altitude robot almost all of the regular quantitative measurements usually associated with meteorology must fall by the wayside. It is impossible to make more than an intelligent guess at the values of temperature, pressure, humidity, and the remaining quantitative meteorological parameters. Because of this, the analyst must rely on the visible components of meteorology to ascertain to some usable degree the synoptic weather situation.

Clouds, being the objects most easily discernible from extreme altitudes, become the important item and must be utilized to the utmost in forming a synoptic picture. It is apparent that from clouds alone it will be impossible to tell everything about the current synoptic situation. Combined, however, with both theoretical knowledge and that gained through experience, an accurate cloud analysis can produce surprisingly good results.

The purpose of this report is to present methods of attack on the above problem, to show what may be actually seen from high-altitude photographs (primarily a discussion on necessary resolution and area coverages), to discuss what may be determined from these photographs (both directly and indirectly), and to give some results obtained. Although all the present analysis is based on data obtained from vertically fired rockets, the experience gained therefrom permits recommendations on possible methods of forming a synoptic picture from satellite-missile photographs.

INTRODUCTION

The foundation of all meteorological forecasting systems is the weather observing network. Whether the forecast is "local" or for the entire Northern Hemisphere, the starting point must be an appraisal of the synoptic weather picture. Since storm systems at middle latitudes generally move from west to east, a meteorologist who does not have good observations from a rather wide area (particularly to the west) is at a disadvantage; and such is often the case for coastal regions, since weather reporting over the oceans is often inadequate.

Although ship reports and weather reconnaissance by aircraft help to some extent to fill the gap, there has long been a need for extending weather observations over the oceans and inaccessible areas. A solution to this problem may lie in weather observations made by means of a television camera placed in an unmanned satellite vehicle. Such a method has the advantage of providing a means of observation of the over-all picture of the wide-scale weather situation that is lacking in normal daily weather observations, and should give new insight into the behavior of the atmosphere.

THE SATELLITE VEHICLE

Owing to the ever-changing pattern of the atmosphere, the need for almost constant surveillance must be foremost in any plan to trace synoptic weather situations. Any vehicle designed for such a purpose must therefore have the ability to make many trips over the area in question. These traverses, moreover, must be made in such a fashion that they not only cover a representative portion of the area, but also complete their cycle often enough to enable an observer to notice any significant change or shift in the cloud systems.

Such a vehicle is the satellite missile. Flying high above the uppermost reaches of the known enemy defenses, the satellite becomes an unparalleled instrument for weather reconnaissance when scope of view is considered. In the current RAND study on the satellite² various operational altitudes ranging between 350 and 500 mi are proposed. For the purpose of simplicity, all calculations and performance considerations in this report will be based on a satellite assumed to be circling the earth at an altitude of about 350 mi. At this altitude such a vehicle³ would have an orbital velocity equal to 24,870 ft/sec⁴ and would make one complete circuit of its orbit in 1.6 hr. Also, because of the fact that this missile is theoretically moving in a stable orbit around the earth, the globe turning under the vehicle causes the trajectory of the satellite to appear to "creep" over the face of the earth, thereby increasing the area observed.⁵ Depending on the efficiency of the powerplant, the order of magnitude of the time period for which the vehicle could be kept operating is thought to be 1 yr. However, in attempting to decide the satellite's full worth for weather reconnaissance, the questions that must be considered are as follows: Can enough be seen from such altitude to enable an intelligent, usable, weather (cloud) observation to be made, and what can be determined from these observations?

² *Ibid.*

³ The actual altitude to which these figures apply is 354.6 mi.

⁴ The actual velocity of a projection of the satellite's image over the face of the globe is really a variable resulting from the change in angular velocity from latitude circle to latitude circle.

⁵ It should be noted that the concept of "repetitive traverses" is in itself complicated in that, regardless of the stability of the satellite orbit, the spatial movement and the oblate shape of the earth impart a regressive motion to the vehicle relative to fixed points on the earth. For a satellite at approximately 350 mi altitude in an orbit set tangent to a latitude of 56°, 78 days will be required for it to appear twice over the same point on earth at exactly the same time. This regressive motion can be partially corrected by an adjustment of the speed (through altitude change) of the satellite. It further imparts a limitation on successful viewing in that for approximately half of the 78-day period (assuming 12 hr of photographable time out of every 24) the desired area will have night at the time of the satellite's passage. For a complete discussion on regression of the orbit, the interested reader is referred to RAND Report R-217 (see footnote 1, p. v).

THE SATELLITE VEHICLE

Owing to the ever-changing

cloud systems.

Such a vehicle is the satellite. Flying high above the sensible part of the atmosphere, so that atmospheric drag becomes negligible, the satellite becomes an unparalleled instrument for weather reconnaissance when scope of view is considered. For the purpose

WHAT CAN BE SEEN

Naturally, any estimate of the amount that can be seen from an extreme altitude must be a function of both the resolving power of the camera system and the area that can be scanned and recorded (or televised) and still retain usable detail. Much of the discussion and most of the figures in this section are the result of previous RAND studies conducted by Dr. R. S. Wehner.

AREA COVERAGE

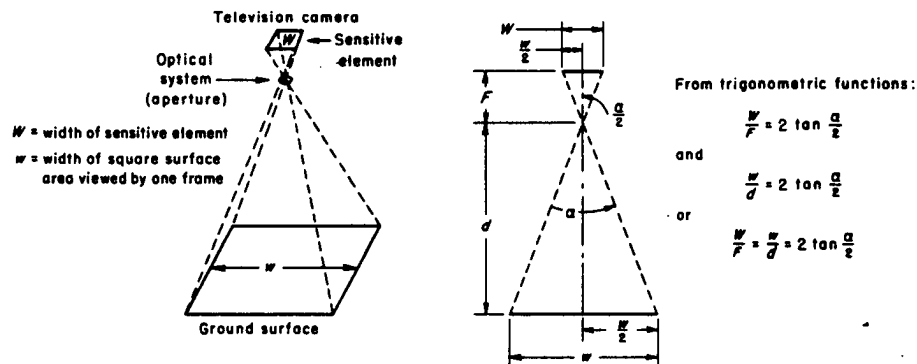

Fig. 1—Viewing system

Using the relation (see Fig. 1)

$$\frac{W}{F} = \frac{w}{d} = 2 \tan \frac{\alpha}{2},$$

where W = sensitive element width, in.
 w = width of surface pictured per frame, mi
 F = focal length of camera, in.
 d = optical range, mi
 α = angle of view, deg,

and using Tables 1, 2, and 3, it is possible to compute the width of square surface viewed and the angle of view for any given camera and aperture. This has been done and is summarized in Table 4. As can be seen, if a limiting resolution⁶ of 500 ft is

⁶ The term "limiting resolution," as used in the television field, refers to the greatest possible resolution attainable by a given TV pick-up tube and is wholly dependent on the structural make-up of the tube itself. As used in this report, limiting, minimum, or usable resolution is a quantity depending on scene contrast, signal-to-noise ratio, aperture, f number of camera, etc., and is chosen to pick up the smallest object that it is desired to view.

set, it is still possible to obtain this resolving power under sunlight illumination with a contrast as low as 2.5 per cent (with a 5.0-in. aperture). Under moonlight, however, this resolution is possible only with 100 per cent contrast, a very fast $f/1.4$ lens, and a minimum exposure time of 0.25 sec; under light of the night sky illumination it is not possible at all. Assuming, then, that the chosen limiting resolution is correct, the probability of obtaining identifiable cloud photographs under any but sunlight illumination appears to be small.

Table 1*
RESOLUTION OF CLOUDS BY SUNLIGHT

(Image orthicon $f/10$ camera operated at 20:1; † signal-to-noise ratio at rates of 40, 10, and 4 exposure frames/sec; and a satellite height of 350 mi)

Contrast (%)	Aperture (in.)	Minimum Resolvable Surface Dimension		
		40 Frames/Sec (ft)	10 Frames/Sec (ft)	4 Frames/Sec (ft)
100	0.5	200‡	100‡	64‡
	1.0	100‡	50‡	32‡
	2.0	50‡	25‡	16‡
	5.0	20‡	10‡	6‡
25	0.5	800	400‡	250‡
	1.0	400	200‡	125‡
	2.0	200	100‡	64‡
	5.0	80	40‡	25‡
10	0.5	2,000	1,000	640
	1.0	1,000	500	320
	2.0	500	250	160
	5.0	200	100	64
2.5	0.5	8,000	4,000	2,500
	1.0	4,000	2,000	1,250
	2.0	2,000	1,000	640
	5.0	800	400	250
1	0.5	20,000	10,000	6,400
	1.0	10,000	5,000	3,200
	2.0	5,000	2,500	1,600
	5.0	2,000	1,000	640

* The material contained in this table was prepared by Dr. R. S. Wehner and is included in RAND Report R-217 (see footnote 1, p. v).

† It should be noted that this table (and also Tables 2 and 3) is unrealistic in that the 20:1 signal-to-noise ratio is applicable only to 25 per cent contrast. For 10 per cent contrast, a signal-to-noise ratio of 50:1 is required. This would mean a required transmitter power increase by a factor of 2.5 (assuming a 2-in. aperture, 1000 TV lines, and a frame frequency of 10/sec). This is still not prohibitive but does become so with a substantial increase in either the number of TV lines or the frame frequency.

‡ Values of computed resolution smaller than realizable with present commercial image orthicons.

C

Table 2***RESOLUTION OF CLOUDS BY SECOND- AND THIRD-QUARTER
MOONLIGHT**(Image orthicon f/1.4 camera operated at 20:1; signal-to-noise ratio at rates of
40, 10, and 4 exposure frames/sec; and a satellite height of 350 mi)

Contrast (%)	Aperture (in.)	Minimum Resolvable Surface Dimension		
		40 Frames/Sec (mi)	10 Frames/Sec (mi)	4 Frames/Sec (mi)
100	5	1.08	0.54	0.34
	10	.54	.27	0.17
	20	.27	.14	0.09
25	5	4.32	2.16	1.36
	10	2.16	1.08	0.68
	20	1.08	0.54	0.34
10	5	10.8	5.4	3.4
	10	5.4	2.7	1.7
	20	2.7	1.35	0.85

* The material contained in this table is included in RAND Report R-217
(see footnote 1, p. v).**Table 3*****RESOLUTION OF CLOUDS BY LIGHT OF THE NIGHT SKY**(Image orthicon f/0.7 camera operated at 20:1; signal-to-noise ratio at rates of
40, 10, and 4 exposure frames/sec; and a satellite height of 350 mi)

Contrast (%)	Aperture (in.)	Minimum Resolvable Surface Dimension		
		40 Frames/Sec (mi)	10 Frames/Sec (mi)	4 Frames/Sec (mi)
100	10	4.3	2.15	1.36
	20	2.15	1.08	0.68
	40	1.08	.54	.34
25	10	17.2	8.6	5.4
	20	8.6	4.3	2.7
	40	4.3	2.15	1.36
10	10	43.0	21.5	13.6
	20	21.5	10.8	6.8
	40	10.8	5.4	3.4

* The material contained in this table is included in RAND Report R-217
(see footnote 1, p. v).

Table 4
POSSIBLE PERFORMANCE CAPABILITIES FOR VARIOUS IMAGE ORTHICON CAMERAS,
TAKING INTO ACCOUNT ILLUMINATION SOURCES

Ratio of Focal Length to Aperture Diameter, and Illumination Source*	Aperture (in.)	Focal Length (in.)	Approx. Minimum Contrast Necessary to Give at Least 500-Ft Resolution (%)	Maximum Number of Frames/Sec	Computed Angle of View of Each Frame (deg)	Computed Width of Square Surface Viewed in Each Frame† (mi)
f/10 camera, clouds illuminated by sunlight	.5	5	25	10	11.44	70
	1.0	10	10	10	5.74	35
	2.0	20	10	40	2.86	17.5
	5.0	50	2.5	10	1.14	7
f/1.4 camera, clouds illuminated by 2nd- and 3rd-quarter moons	5	(‡)	(‡)	(‡)	(‡)	(‡)
	10	(‡)	(‡)	(‡)	(‡)	(‡)
	20	28	100	4	2.05	1.25
f/0.7 camera, light of night sky illumination	...	(**)	(**)	(**)	(**)	(**)

NOTE: For the purpose of computation, in the relation written on p. 3:
 W = width of the target in inches, which is taken to be equal to 1 in., the size of the commercial RCA image orthicon target

d = optical range, which is taken to be equal to 350 mi (the height of the satellite).

All computations made assuming a minimum signal-to-noise ratio of 20:1.

* All cameras mentioned here refer to those using an image orthicon tube.

† Since the curvature of the earth was not taken into account, the figures in this column are lower than the actual figures.

‡ No resolution of the order of 500 ft or less.

** No resolution of the order of 500 ft or less, regardless of aperture.

C

Calculations must also be performed to arrive at the possible area coverage. Since it is apparent that cloud observations, to be at all useful, have to be made over a wide-enough strip (at least as wide as the height of the satellite), it should be considered that the camera will be mechanically scanned. This may be accomplished by means of a 45° plane mirror rotatable about the axis of the camera. The mirror actually does the "looking" and scanning for the camera, which is mounted horizontally, its axis being parallel to the axis of the missile. Taking a sequence of 20 nonoverlapping frames will produce a strip 350 mi long, transverse to the trajectory of the satellite, and 17.5 mi wide. If the camera is set to take 5 frames/sec and the rotatable mirror is fixed with a fast snap-back device, the system will then be in position to take a second strip by the time the satellite has moved ahead approximately 17.5 mi relative to the earth. (The speed of the missile relative to the earth's surface is about 4.4 mi/sec.) This will produce a continuous 350-mi wide strip around the earth with each complete traverse of the missile.

The daylight camera with an $f/10$ lens and an image orthicon television tube and whose performance is summarized in Table 4, should have a 2-in. objective to give the proper ground coverage per frame. This combination allows a 500-ft object to be resolved with only 10 per cent contrast,⁷ which is reasonably small. It should be emphasized that these figures are presented here merely to give some *examples* of performance of viewing systems and not as a description of the *optimum* system performance.

Some calculations of total area coverage were also made by direct measurements (assuming different strip widths) on a scale map of Russia. On this map were projected complete cycles⁸ of traverses for two proposed satellite trajectories. Once again, curvature of the earth was neglected. The results obtained are as follows:

1. For a satellite with 24-hr complete cycle (354.6 mi altitude, angular velocity 15 times that of earth, and trajectory tangent to lat. 56°N . (Moscow)

Assuming a 100-mi-wide scanning band (50 mi on either side of path): In the vicinity of lat. 45° - 50°N ., taking an area of approximately 105,000 sq mi, we find that in 24 hr the surface has been covered in a grid fashion such that about one-third (32,500 sq mi) of its area has been scanned and presumably televised.

Assuming a 200-mi-wide scanning band (100 mi on either side of path): As may be expected, doubling the scanning band does not quite double the area covered. This is owing to some overlapping of the bands. (It can be shown that,

⁷ This resolution and contrast represent the maximum needs of satellite weather observation. As pointed out in the general report on the satellite, 200-ft resolutions are available for reconnaissance. This is obtainable with 25 per cent contrast when using an $f/10$ lens with a 2-in. objective in sunlight illumination (see footnote to Table 1 marked (†)).

⁸ Initially, the trajectory of the satellite is set tangent to a given latitude. Owing to the relative difference in the angular velocities between the satellite and the earth and to the relative stability of the orbit of the missile, the vehicle's trajectory appears to "creep" over the surface of the globe. A complete cycle is the time it takes for the trajectory of the satellite once again to become tangent to the original point. (This "creep" causes the traverses to become more widely dispersed as the trajectory approaches the equator.)

R-218
7a

Some calculations of the efficiency of coverage of an inaccessible area such as an ocean were also made by direct measurements (assuming different strip widths) on a grid map. On this map were projected complete cycles⁸ of traverses.....

(Note deletions on page 7)
& 8.

to cover the area completely, a scanning band approximately 450 mi in width is needed.)

As a result of the grid-like coverage, the 100-mi-wide band, at its worst, should pick up at least portions of the largest, most active weather disturbances and enough of the remaining cloud coverage to orient the system in relation to the ground.

2. For a 48-hr complete cycle (altitude 453.3 mi, angular velocity 14.5 times that of the earth, and trajectory tangent to lat. 56°N. (Moscow)

Assuming a 100-mi-wide scanning band (50 mi on either side of path): In the vicinity of lat. 45°-50°N., using a region of approximately 231,000 sq mi, we find that in 48 hr it has been covered, grid fashion, so that two-thirds of its area (148,400 sq mi) has been scanned and presumably televised. (It can be shown that to cover the area completely in a 48-hr cycle a scanning band approximately 250-300 mi in width would be required.

The results so obtained give an idea of the areas which can be covered (or scanned) from a vehicle in an orbit 350 mi above the surface of the earth. The 350-mi-wide strip discussed in the first part of this section will therefore cover in 24 hr a large percentage of the area between 45°N. and 56°N. over Russia⁹ with considerable overlapping of scanning, particularly around the 56th parallel. In any event, the coverage, as mentioned here, if achieved with any measure of success, should produce good weather reconnaissance results.

RESOLUTION AND LIMITING CONTRASTS

Since it is now obvious that clouds will be the chief meteorological element directly observable from high-altitude photographs, it must be ascertained how closely these clouds may be identified and what may be determined from them, either directly or indirectly.

As can be seen from Tables 1, 2, and 3, when a set of conditions such as aperture, illumination, exposure time, and focal length-aperture diameter ratio of a given camera have been established, the remaining factor for determination of the minimum resolution attainable is the contrast value. In cloud photography of the type to be attempted from the satellite, one is unable to choose the surrounding photographic conditions. Features such as background, lighting at time of observation, etc., are examples of the uncontrolled variables, and, as a consequence, any system of data gathering by photographic means must be flexible enough to give adequate results over a wide range of limiting factors. The question is: If the camera and optical system are chosen,¹⁰ and if the various conditions of lighting, background, etc., are assumed to remain within the limits providing

⁹ A large percentage of the area should be covered in the 24-hr trajectory, and almost all should be scanned in the 48-hr trajectory.

¹⁰ Previous studies at RAND have shown that one of the best available television cameras for use in the satellite would be one employing an *image orthicon pick-up tube*. The characteristics of this tube approach those of the human eye over part of its operating range, it has a greater sensi-

usable resolution, will the resulting limiting contrast values still enable one to observe the weather under a wide-enough range of actual conditions?

Before endeavoring to answer this question it is desirable to define the term "usable resolution." It was thought that details of cloud structure as small as several hundred feet in diameter might possess significance when an attempt was made to form a synoptic picture by means of cloud analysis. This was borne out when high-altitude rocket photographs were examined. Further reasons for assuming this to be the approximate minimum size to be resolved were found when a simple test was conducted on these photographs. (The heights at which these pictures were taken varied between 50 and 70 mi.) Using an adjustable viewer, the photograph was taken slowly out of focus until it was impossible to identify definitely the forms of clouds other than by saying that they were widespread or were in small clusters. For example, beyond this point it was impossible to distinguish between closely packed cumulus and a deck of altocumulus, and also between a dense layer of stratus or altostratus and the fibrous texture of cirrostratus. A study of other parts of the photograph, where recognizable or measurable objects were located at ranges about equal to those of the clouds, showed that the limiting resolution at which the clouds lost their distinguishability was from 500 to 1000 ft. This is what is meant by "usable resolution." As may be imagined, this is at best only a rough approximation, but because of its apparent agreement with previously estimated values it should serve very well as a working basis.

It was mentioned above that in order to obtain a known, usable resolution, once the camera and lighting conditions are chosen, the limiting contrast value must also be specified. It is obvious that if, for various combinations of cloud-ground and cloud-cloud, albedo differences are such that their contrast values fall below the limiting contrast, these combinations cannot be observed by high-altitude weather reconnaissance.

Hewson, in an article in a meteorological journal¹¹ and in his book (written in collaboration with Longley) on theoretical and applied meteorology,¹² calculated and tabulated diffuse-reflection coefficients for clouds of various thicknesses. In doing so, as a result of the extensive variation of cloud liquid-water densities and cloud droplet radii, he was forced to choose one set of values for these two parameters. Those on which his figures are based are a density of 1.0 gm of liquid water per cubic meter of cloud and a droplet radius of 5×10^{-4} cm. Owing to the fact that these values probably apply to a large percentage of the usable clouds observable from extreme altitudes, they may be reasonably

tivity than earlier types, and it is capable of stable operation without adjustment over a wide range of illumination intensity. Since it is not the purpose of this report to delve too deeply into the technical aspects of the problems of a television viewing system, only results of resolution computations for the image orthicon tube are presented here. These are summed up in Tables 1, 2, and 3. For technical information and equations involved, see R. B. James, R. E. Johnson, and R. S. Moore, *RCA Review*, Vol. 10, July, 1949, pp. 191-223; and A. Rose, "Television Pickup Tubes and the Problem of Vision," *Advances in Electronics*, Vol. 1, Academic Press, New York, 1948.

¹¹ E. W. Hewson, *Quart. J. Roy. Met. Soc.*, Vol. 69 (1943), p. 47.

¹² E. W. Hewson and R. W. Longley, *Meteorology, Theoretical and Applied*, John Wiley & Sons, Inc., New York, 1944, pp. 73-75.

employed in making estimates for this study. These values are plotted in Fig. 2, the ordinate and abscissa being contrast and background albedo, respectively. Each curve represents a particular albedo applicable to a particular cloud thickness. According to the definition of contrast,

$$C = \frac{\rho_b - \rho_d}{\rho_b},$$

where ρ_b = brightness (albedo) of the brightest thing viewed
(either object or background)

ρ_d = brightness of darkest object viewed (albedo)

C = contrast between the two.

From the above definition, each curve may be represented by the following relation:

$$C = \begin{cases} 1 - \frac{A_b}{A_t}, & \text{for } A_b < A_t \\ 0, & \text{for } A_b = A_t \\ 1 - \frac{A_t}{A_b}, & \text{for } A_b > A_t, \end{cases}$$

where C = contrast between object and background

A_b = albedo of background

A_t = albedo of clouds of various thicknesses.

It is therefore seen that, except for the small range of albedo combinations around the point of discontinuity on the curves, a large majority of possible cloud-background albedo combinations fall within the range of at least 10 per cent contrast. As can be seen from Table 1, assuming at least a 2.0-in. aperture and sunlight illumination, an f/10 camera will permit at least 10 per cent contrast for approximately 500-ft resolutions.¹³ Table 5 (page 12) gives the albedos for various ground covers. Applying these values to Fig. 2, it can be seen that, except for the case of newly fallen snow combined with clouds thicker than 600 meters and the case in which the background albedo approaches very close to cloud albedo, 500-ft resolutions are obtainable over a wide range of conditions.

There is one other factor that might limit contrast and, therefore, resolution. This is aerial haze between the camera and the ground. As has recently been shown in several

¹³ Using the equation (for altitude of 350 mi)

$$C = \frac{1600}{\delta a \sqrt{t}},$$

where C = contrast

a = aperture

t = exposure time (or time of one frame)

δ = minimum resolvable surface dimension,

it is possible to calculate the contrast (minimum) needed to obtain at least 500 ft resolution under the conditions given in the example on ground coverage which assumed full daylight illumination. This value turns out to be 3.56 per cent. Owing to the unrealistic power requirements necessary to transmit 3.56 per cent contrast, this value has been raised to 10 per cent.

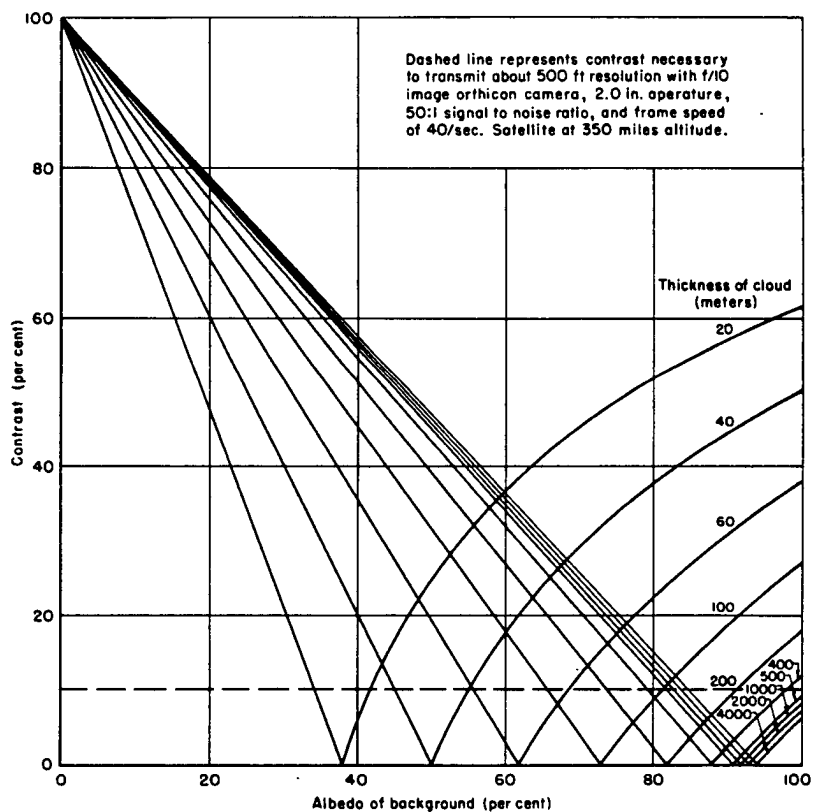

Fig. 2—Available contrast with varying cloud and background albedos

V-2 photographs, this problem is almost completely solved by use of an infrared filter in the optical system.

From the foregoing section we may conclude that, from the standpoint of area coverage and resolution, weather observations from a satellite are a definite possibility.

Table 5*
SURFACE ALBEDO AND SCENE CONTRAST OF CLOUDS
AGAINST VARIOUS BACKGROUND SURFACES

Ground Surface	Albedo†	References‡
Fresh snow	.80-.93	1, 3, 4
Old snow, sea ice	.40-.60	3, 4
Brown soil	.32	1
Grass	.10-.33	4
Green leaves	.25	1
Sandy loam	.24	2
Sand	.13-.18	3
Asphalt paving	.15	2
Dry earth	.14	4
Rock	.12-.15	4
Moist earth	.08-.09	2, 4
Cultivated soil, vegetable	.07-.09	3
Smooth sea surface		
Solar elev 5 deg	.40	3
Solar elev 10 deg	.25	
Solar elev 20 deg	.12	
Solar elev 30 deg	.06	
Solar elev 40 deg	.04	
Solar elev 50-90 deg	.03	

* This table was prepared by Dr. R. S. Wehner and is included in the RAND general report on the satellite (see footnote 1, p. v).

† Values of albedo apply to illumination by "white" light or sunlight.

‡ References:

1. *International Critical Tables*, 1929 ed., Vol. 5, p. 262.
2. *Handbook of Chemistry and Physics*, 1942 ed., pp. 2147-2148.
3. H. Landsberg, *Handbook of Meteorology*, McGraw-Hill Book Company, Inc., New York, 1945, p. 932.
4. J. Charney, *Handbook of Meteorology*, McGraw-Hill Book Company, Inc., New York, 1945, p. 296.

LIMITATIONS OF THE ANALYSIS

It is a known fact that the reliability of any form of synoptic meteorological analysis depends on the experience of the analyst. An analysis of the type dealt with in this report is no exception. If anything, it is even more dependent on analytical experience because of the sparseness of data and the difficulties in interpretation. To date, the meteorological cloud atlas has been built up almost entirely from ground observations. The change-over to "looking down" upon the clouds means that the dominant features which served to identify types of clouds when observed from the ground are no longer to be seen. The halo and corona that served so well to classify cirrostratus and altostratus, respectively, are absent. Also, the upper surface of large-scale cloud decks is, for the most part, completely different in appearance from the lower surface. Therefore a completely new concept of cloud-identification features must be formed, and only those experienced in these new concepts will be able to make an intelligent analysis.

There is also danger of an incorrect interpretation of the cause for the clouds, which might lead to a completely erroneous analysis. Take, for example, the case in which the entire picture under consideration exhibits one complete deck of clouds. In this case the deck of clouds might be stratus caused by radiational cooling and so might constitute an entirely local phenomenon. An analyst looking at this situation might jump to the conclusion that the clouds in question were of frontal origin, possibly altostratus, and might forecast accordingly. It is evident that a forecast made from such an erroneous assumption of the cause would be completely incorrect. (Methods of attack on this problem of analysis are treated more fully in a later section of this report.)

There are also many definite advantages to be gained in the analysis of weather by this method; chief among these is the fact that extremely large areas may be visually observed in a relatively short period of time. The disadvantages of large gaps (between stations) on the usual weather map and the comparatively limited field of view of each ground observer are eliminated. What is obtained is, in effect, the cloud pattern integrated over a wide area. From many points of view this is highly desirable, owing to the fact that, for the first time in the history of synoptic meteorology, the classical models of various weather situations may be examined *in toto*.¹⁴

¹⁴ This idea of "the over-all look" was first described by Major D. L. Crowson, USAF, in a recent article in the *B. Amer. Meteorol. Soc.*, Vol. 30, No. 1, January, 1949. His primary object was the use of vertically fired rockets in conjunction with the regular meteorological observations as a supplement rather than as a possible replacement. In this regard, his analysis of rocket photographs is very similar to that presented by Dr. J. Bjerknes in Appendix I.

WHAT CAN BE DETERMINED FROM HIGH- ALTITUDE OBSERVATIONS

CLOUD IDENTIFICATION

Assuming, from the previous section, that cloud shapes of the order of 500 ft or more in diameter are distinguishable from an altitude of 350 mi, the problem of identifying these clouds can be treated. As stated previously, attributes and/or phenomena that served to establish the classification of clouds when viewed from the ground are almost completely different when these same clouds are viewed from above. The question is, What can actually be done to tell the various cloud forms apart?

The solution to this problem may lie in a new classification system formed by means of close correlation of observations of clouds viewed from above with observations of these same clouds viewed from below. In this manner, an atlas of identifying cloud features as scanned from extreme altitudes might be built up. Using this information, a trained observer should have little trouble in establishing the identity of almost any visible cloud. The importance of such an atlas cannot be over-emphasized, because the degree of confidence in a synoptic picture formed from this type of observation or in the subsequent forecast becomes extremely small if the identity of the clouds cannot be established. An attempt along these lines has been made, utilizing several series of photographs taken from V-2's fired at White Sands, New Mexico. It should be kept in mind, however, that this attempt was made using data which were not originally gathered for this purpose, and the necessary ground observations are therefore not available for positive identification purposes. Because of this, the results presented here are a classification and identification based on the writer's observational experience.

From a study of the above-mentioned photographs it was observed that two general cloud forms stand out from each other under the usable resolution conditions. Since these two forms are also two types of cloud formations, most other clouds can be considered as being a special form or combination of these and may be so categorized. This is partially attempted in the table on the opposite page.

It is noticed that certain formations of clouds very often assemble in over-all patterns peculiar to these formations. Clouds, therefore, may also be partially categorized according to pattern. In the case of clouds formed by globular masses joined together to produce a single layer, the pattern is still apparent to an observer on the ground as a result of the differences in light intensities caused by the variations in cloud thickness. It is likely, therefore, from the section on cloud contrast, that these patterns will also be visible to an observer stationed above the layer, owing to the difference in albedo values caused by cloud sections of different thicknesses. These patterns are very useful in cutting down the overlap present in the following table.

A		B	
Vertically Developed	Remarks	Stratiform	Remarks
1. Cumulus 2. Cumulonimbus }	Varying degrees of vertical development	1. Stratus } 2. Altostratus }	In some forms may be very similar.
		3. Cirrostratus	May be distinguished because fibrous texture is visible even when viewed from above.
		4. Nimbostratus	When there is no vertical development on top this form may appear to be very similar to Nos. 1 and 2.

Combinations of A and B (forms similar in appearance are bracketed)

Cloud Formations	Remarks
[Altocumulus] [Cirrocumulus]	Altocumulus cloud elements may exhibit vertical development, or there may be just closely packed globular masses. In the first case, the altocumulus may seem to be very similar to altostratus or nimbostratus that have vertical development in their tops, although the layer may retain some semblance of orderly pattern.
[Altostratus] [Nimbostratus]	Very often these formations contain considerable vertical development. This seems to be especially true when these forms are associated with the passage of a front.

It is clear that any attempt to formulate an atlas of cloud appearance as seen from high altitudes is a major undertaking. The work done on the subject in this report represents, at best, the beginning of the work that must be accomplished to make high-altitude cloud photographs a usable weather tool.

THE ANALYSIS

Having once established the identity of almost all the clouds viewed, the formation of the synoptic weather picture becomes the next problem. The following question arises: Given an over-all cloud picture, what, in fact, can be determined, either directly or indirectly?

According to conventional meteorological practice, the various parameters, such as pressure, temperatures, etc., are plotted on a map, and the subsequent analysis of these quantities produces the synoptic picture. Almost the reverse is true in the case at hand. Here the synoptic situation must first be established, and the various parameters must be estimated from it. Actually, it is not quite so straightforward a procedure. Rather, it becomes a "hunting" technique, in which one makes a first approximation to the over-all weather situation, using the clouds, and, from this, a first estimate of the value of temperature, pressure, humidity, etc. This picture of the weather is then modified to fit

obvious deviations of the estimated values from those indirectly observed. This process continues until a satisfactory situation is evolved that appears to fit all existing conditions (an attempt being made to satisfy both physical and theoretical considerations); from this, final estimations of the various parameters are made. (Several possible approaches to the problem of approximating the synoptic picture are discussed in the section entitled "Suggested Methods of Attack on the Problem of Determining the Synoptic Situation," page 22.)

The normal observable meteorological parameters may be divided into two main categories, viz., those that may be estimated in some measure directly from observations of the clouds and/or ground, and those that require a knowledge of the over-all weather patterns before an estimate can be made. In the first category may be listed wind, humidity, precipitation, and a variable not normally considered by itself as such—degree of stability. In the second listing may be found pressure (and pressure tendency) and temperature. Before an attempt at its analysis can be made, a considerable amount of experience and general knowledge of the workings of the atmosphere is required concerning each item, regardless of which category it comes under. It is found that this estimation method is neither a quick nor a simple process, regardless of the qualifications of the analyst. Rather, each of the items requires a very careful study and the weighing of all the possible influencing conditions before approximate values can be assigned.

As a result of this pilot study, several suggested methods of estimating the various meteorological parameters were evolved and are discussed as follows:

Wind

1. From the established meteorological models it is assumed that certain definite weather situations will produce certain sequences of clouds preceding or following them. This will therefore tend to orient the situation with respect to the ground. Once this orientation has been established, the wind direction may be approximated through a knowledge of the theoretical circulation associated with a given synoptic weather situation.

2. It has been noticed in several photographs that, in the presence of strong upper winds, cumulus clouds that have formed in mountainous country appear to form to the lee of the mountains rather than to their windward side. In the presence of very light winds, it was noticed that the cumulus tended to form on the peak of the mountain. This phenomenon requires further study before its degree of usefulness as an observational tool can be determined.

3. Owing to the fact that cumulonimbus clouds extend from as low as 1600 ft up to 40,000 ft, their slope becomes a good indication of the vertical shear within the layer. It was first thought that this direction of slope would be an indication of the direction of the upper winds. However, although the wind velocity normally increases with altitude, it is obvious that for any given case one should not disregard the possibility that the wind velocity might decrease with height or that the direction and velocity distribution in the vertical might be of such a nature as to cause the cumulonimbus to slope into the upper wind. When this slope is combined with other factors that indicate wind direction

at one particular level, it may be possible to construct a picture of the change of wind direction with height in the layer under consideration.

4. A further indication of wind direction (in the lower levels) was observed when small, detached clouds were seen to form in line, streaming from a mountain top. These could be due to moist air being forced upward by the mountain and then moving down-slope on the lee side, causing the formation of small "rotors" or individual cellular eddies each capped by small cumulus clouds and extending for a considerable distance downwind from the mountain. This phenomenon is known as a "standing wave" and is often accompanied by other standing clouds at higher altitudes.

5. It has also been observed in a layer of stratus overlying mountainous terrain that air funneling down a valley and spreading out in a relatively flat section produced lines and swirls in the top of this cloud layer that closely matched the path the air must have taken. This action may be very useful in determining wind direction in sections completely covered by sheet-type clouds and may be found to be of further use over areas that are not particularly mountainous. Although photographs of large flat areas were not available for analysis, it is thought that wind-direction determination in these sections may still be accomplished in the lower levels. This may be done by utilizing many of the above methods and several others that could be an outgrowth of such an analysis. One such method might use the inherent uniform structure of a stratus sheet. In this case it is thought that if a sheet passes over flat ground on which there are isolated protuberances projecting into the sheet, a wake will be produced in the cloud that may also show up when viewed from above and that will stretch downwind from the object.

Temperature

The starting point for any determination of temperature must be the statistical normal for that time of the year. The first estimation may then be modified by the various affecting conditions. The prevailing weather situation provides the first modifying influence. This estimation is, of course, dependent on the analyst's ability to estimate the synoptic conditions with a degree of accuracy that will answer the question, Is the sector under observation being affected by relatively cold or warm air? Cloud systems, wind directions, and even forms of ground cover (snow, etc.) will help in deciding this. This is the first indication of the over-all complexity of this type of analysis and serves as an actual illustration of the "hunting" technique mentioned above.

Upper air temperatures may be estimated in the same manner, clouds indicating the boundaries between air masses (fronts). A further help in estimating this quantity is the fact that, once having decided on a ground temperature, the degree of stability (indicated by vertical development in clouds) and the presence or absence of intervening fronts will enable one to construct an applicable temperature lapse rate. (The degree of stability will determine the departure from an adiabatic lapse rate, while the degree of cloudiness (moisture) will help an analyst to decide whether to use the moist or the dry adiabatic lapse rate as the limiting one.)

Vertically developed cloud will also aid in determining the temperature gradient of the surrounding area. This is true because of the fact that the vertical shear, as indicated

by the slope of towering cumulus and cumulonimbus clouds, orients the direction of the higher and lower temperatures in the area. This method is employed by taking the direction of vertical shear as being from the low levels toward the high levels. If one then faces in the direction of shear in the northern hemisphere, the lower temperature will be on the observer's left and the higher on the observer's right (see Fig. 3).

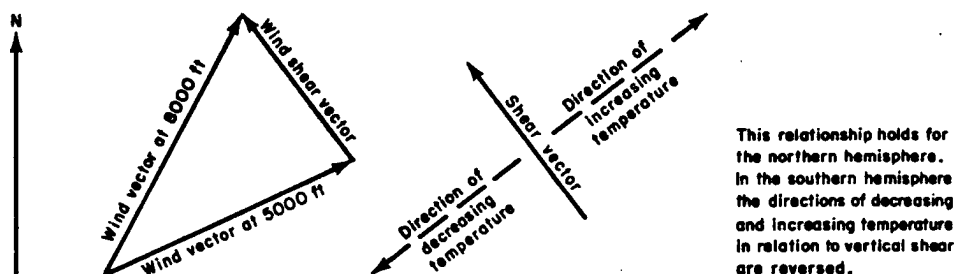

Fig. 3—Vertical wind shear—temperature gradient relationship

Pressure

It is apparent that no quantitative values of pressure are forthcoming from this analysis. Furthermore, it is virtually impossible even to make a quantitative estimate other than to state whether the area is thought to be under the influence of a high- or a low-pressure system. Charts of average pressures for various times of the year in different areas of the world are available. Using these and the weather situation at the time, trends of pressure may be established. This information when applied in conjunction with known weather on the perimeter of Russia may be a very useful tool for forecasting purposes. Little work has been attempted on this subject in this pilot study, and the above should serve only as a possible starting point for any detailed research along these lines.

C. F. Brooks¹⁵ points out some further pressure information that may be obtained from clouds. He says, in effect, that, since in the presence of any constant vertical shear the cumulus clouds will tend to lean or slope (the amount of departure from the vertical being a resultant of the vertical velocity and the rate of change of wind velocity with height), any cloud that has a uniform rate of vertical growth and a 90° slope throughout is an indication of the "uniformity of wind velocity in all layers pierced." This indicates a decrease of horizontal pressure gradient with height. (This can be shown very simply by an examination of the geostrophic wind equation

$$V_g = \frac{1}{\rho} \left(\frac{\partial p}{\partial n} \right) \frac{1}{\lambda},$$

where V_g = the geostrophic wind velocity
 ρ = density of air
 $\partial p / \partial n$ = horizontal pressure gradient
 λ = Coriolis parameter.

¹⁵ C. F. Brooks, "Clouds in Aerology and Forecasting," *B. Amer. Meteorol. Soc.* J-22, November, 1941, pp. 335-345.

It can be seen that since λ , which depends on the sine of the latitude, will remain constant and ρ decreases with height, $\partial p/\partial n$ must also decrease for V_g to remain constant.) This decrease turns out to be very small when actual values are used. In the case of a uniformly growing cumulus that slopes in its lower layers and then straightens or even bends back on itself with increasing height, the decrease of the horizontal pressure gradient with height is (as Brooks also points out) much stronger than in the previous case. If one assumes that the slope of vertically developed clouds may be observed from 350 mi altitude (at least at the edges of scanning strip), further pressure data may be gathered.

Degree of Stability

As has been mentioned above, the degree of stability in a given layer may be estimated by the amount of vertical development present in clouds. In any mechanism of vertical development, the stability of the air plays a major part. Convective, orographic, or upslope lifting may produce clouds in the absence of instability, but, for any large-scale vertical build-up of clouds, a great tendency for the atmosphere to "overturn" must be present. (Absolute instability is taken to mean that the decrease of temperature with height is greater than the dry adiabatic lapse rate. In the presence of unsaturated water vapor, the dry adiabatic lapse rate is about $9.8^\circ\text{C}/\text{km}$, whereas, in the presence of saturated water vapor, the smaller saturated adiabatic lapse rate with a nonlinear variation of temperature is used.) In the presence of water vapor, the latent heat (energy) of condensation that is released when the air is forced to rise and its moisture forced to condense may be sufficient to continue independently the upward motion. This motion indicates a condition of instability where none may have existed at the beginning of the process. Continuation of this motion, therefore, indicates the instability of the air in the presence of saturated water vapor and is evidenced in towering cumulus or cumulonimbus. If, on the other hand, condensation occurs but the ascending air is not provided with a sufficiently large amount of heat so as to warm it to a higher temperature than that of the surrounding air, the layer is considered absolutely stable and may be characterized by smooth, flat-topped cloud forms, usually arranged in layers or sheets. This is also true when a small layer of instability is "capped" by an inversion (increase of temperature with height). This concept of absolute stability, absolute instability, and conditional instability (unstable or stable depending on whether the water vapor present condenses or not) is presented graphically in Fig. 4.

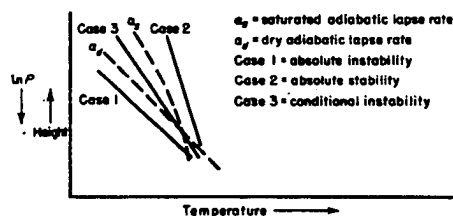

Fig. 4—Graphical representation of degrees of stability as given by lapse rate of temperature

It may be said that, in the presence of vertically developed clouds, a dry adiabatic lapse rate (or very close to it) exists below the base of the cloud, a relatively steep lapse rate exists within the cloud, and a relatively stable lapse rate exists above the cloud. In

the case of flat-topped or sheet-type clouds, it may be that, although instability may exist in a small layer comprising the cloud, an inversion layer of very stable air exists immediately above, causing the cloud to stop its vertical growth.

In his paper on clouds, Brooks¹⁸ suggests the following further refinements on this:

1. Detached, lumpy cloud with a flat base and rounded top has (a) adiabatic lapse rate below it, (b) greater than saturated-adiabatic lapse rate (unstable) within the cloud, and (c) almost the same lapse rate as (b) (unstable) from its top to the height that the cloud will grow.
2. Towering, sharply-bounded cumuliform cloud: The diameter of cloud at different levels is an indication of the relative steepness of the lapse rate (except in the presence of large wind shear). "The narrower such a cloud or cloudlet is, relative to its height, the greater the lapse rate of the surrounding air."

This provides one with very rough criteria for estimating the degree of stability of the air.

To sum up, water vapor in the air is a latent source of heat energy. When moist air is carried rapidly upward, the water vapor condenses in the form of liquid droplets and the latent heat of condensation is released to the surrounding atmosphere. It is this source of latent heat that feeds thunderstorms and other types of vertically developed clouds. Cumulus clouds are an indication of moisture and relative instability, and, conversely, when there is moisture in the air there will be a greater tendency toward convection and turbulence.

Moisture

Clouds, being composed of water droplets, naturally indicate the presence of moisture in the atmosphere (see the above section). Resulting from the difference in formation conditions, cloud types can give a further breakdown of moisture distribution. For example, cumulus and cumuliform clouds of vertical development require the entrainment of continuous supplies of moist air to prevent their complete evaporation shortly after forming. It can therefore be said that with this type of cloud we may associate fairly moist air near the surface. In like manner, positioning of the moisture in the atmosphere may be associated with other cloud forms, and an over-all estimate may be made from visual observations. Once the synoptic picture has been established, closer estimates may be made utilizing the other meteorological parameters, and the value of moisture content may be worked into the "hunting" technique previously mentioned.

Precipitation

Although it will not be possible to observe any form of precipitation directly, it is known that the largest amounts usually fall from two main types of clouds: cumulonimbus (showers—hail, rain, snow, etc.) and nimbostratus (steady precipitation, sleet, etc.). Furthermore, the probability of precipitation in one form or another, which arises whenever these types are present, is higher than for any other types of clouds. Further infor-

¹⁸ *Ibid.*

mation may be obtained from the fact that it may be possible to distinguish between newly fallen snow and old snow, owing to a difference in albedos (see Table 5, page 12), and the new snow may then be connected with the proper form of cloud observed downwind from it.

SUGGESTED METHODS OF ATTACK ON THE PROBLEM OF DETERMINING THE SYNOPTIC SITUATION

From the above discussion it can be seen that the analysis is based primarily on cloud observations. During the course of this study several systematic methods of accomplishing these presented themselves. Although neither time nor proper data were available for a complete study of these possibilities, the most promising were considered and are presented herewith as a guide to any more intensive study.

1. It is suggested that a typing of clouds as to *cause* rather than *appearance* will greatly facilitate the identification of the synoptic situation. Classification into two main categories would constitute a possible breakdown, as follows: (a) Regional clouds (those caused by purely local conditions), and (b) migrating cloud systems (clouds that appear to move as a unit). This breakdown might then be coupled with a knowledge of the clouds associated with various weather phenomena to complete the synoptic picture.

2. It is a recognized fact that similar synoptic situations occurring under different climatic and/or topographic conditions may produce radically different weather. A statistical analysis is therefore suggested, in which (a) the desired area is divided into small regions of similar climate, geography, etc., and (b) a statistical survey of cloud types and associated weather found with various weather situations (fronts, etc.) in each region is made.

3. Owing to the fact that identification of fronts as fronts may be very difficult, it is suggested that it may be possible to identify air masses from high-altitude pictures and to utilize them in the formulation of the synoptic picture. Since general classifications of air masses include as integral identifying features the stability of the air, the moisture, and the type of clouds produced in a given air mass, this should not be too difficult, in many cases. An air-mass identification has the further advantage of establishing more closely the possible limits of the various meteorological parameters.

4. A further possible method assumes the ability to secure synoptic, essentially perimeter, weather information from all parts of the world other than Russia. On this basis all weather systems entering and leaving the area will be known, and a measure of continuity will be established. It is a relatively simple matter to identify a system once it is known that such a system is present. Once a weather situation is so identified, it can be earmarked from high-altitude pictures, and not only may it then be tracked throughout the desired area, but any over-all changes or modifications that affect the visible parameters may be almost immediately noticed. It is also likely that, having a complete analysis of the surrounding territory and many satellite observations of the unknown area (through which it is possible to get fixes on systems and to examine

**SUGGESTED METHODS OF ATTACK ON THE
PROBLEM OF DETERMINING THE
SYNOPTIC SITUATION**

From the above.....

1.
2.
3.

4. A major advantage of satellite weather observations is the repeated broad spatial coverage. Such broad coverage provides the meteorologist with an essential element for his analysis, which is generally referred to as continuity. It permits him to follow a given system as it moves and develops over a period of days. It is a relatively simple matter to identify a system once it is known that such a system is present. Once a weather situation is so identified, it can be earmarked from high-altitude pictures, and not only may it then be tracked across an inaccessible area like an ocean, but any over-all changes or modifications that affect the visible parameters may be almost immediately noticed. It is also likely that, having a complete analysis of the surrounding territory on land, where observations are plentiful, and many satellite observations of the unknown area (through which it is possible to get fixes on systems and to examine

visually the over-all weather picture), a complete analysis of the desired region will become a much simpler thing to construct.

Each of the above suggestions affords excellent possibilities of providing the required information. It should be kept in mind, however, that these suggestions appear to offer the best solution when systematically used together.

RESULTS OF THREE ATTEMPTS AT ANALYSIS

As discussed previously, an attempt at a weather analysis was made, in which aspect photographs taken from vertically fired rockets were used. Very little information was used other than that supplied by the applicable surface weather map with which to check the results.

These results should not be construed as proving or disproving any of the previous discussion, as the observations were not conducted as a test of the suggested methods. Rather, these attempts were conducted in order to gain experience in handling the problem, and the results are presented merely for the background information.

VIKING NO. 3 (NRL)

Date of firing.....	Feb. 9, 1950
Time of firing.....	1444 MST
Peak altitude.....	49.5 mi
Time to peak.....	169 sec

What Was Observed

Because of the tilt and rotation of the rocket near peak altitude, the pictures there are divided into sequences of nine frames, each interspersed with shots of the sky. Since each sequence views what is relatively the same area, only one set need be used. Fogginess of the film prevents positive orientation or identification of clouds. From a knowledge of past performance, however, the rocket is assumed to be oriented as shown in Fig. 5, and cloud types are estimated from over-all appearance and contrast. The apparent cloud picture is as follows:

Over the launching area there appears to be some cirrus and cirrostratus. A layer of thicker clouds, apparently altostratus, spreads away from this area and back toward what appears to be a line of convergence in the west and northwest. There is some noticeable vertical development and possibly some nimbostratus closer to this line of convergence. The vertical development observed appears both as detached masses (the type that might be associated with orographic or convective lifting) and as that occurring in the tops of stratiform clouds.

Synoptic Situation—Preliminary Estimate

The layer of what appears to be cirrostratus is indicative of convergence in the upper layers and possibly indicates convergence and a low-pressure center at the surface (to the west of the cirrostratus). In the case at hand, this is further verified by the presence of a considerable deck of altostratus further in the distance. This type of cloud cover is normally associated with upslope motion, and, judging by the prevailing winds aloft,

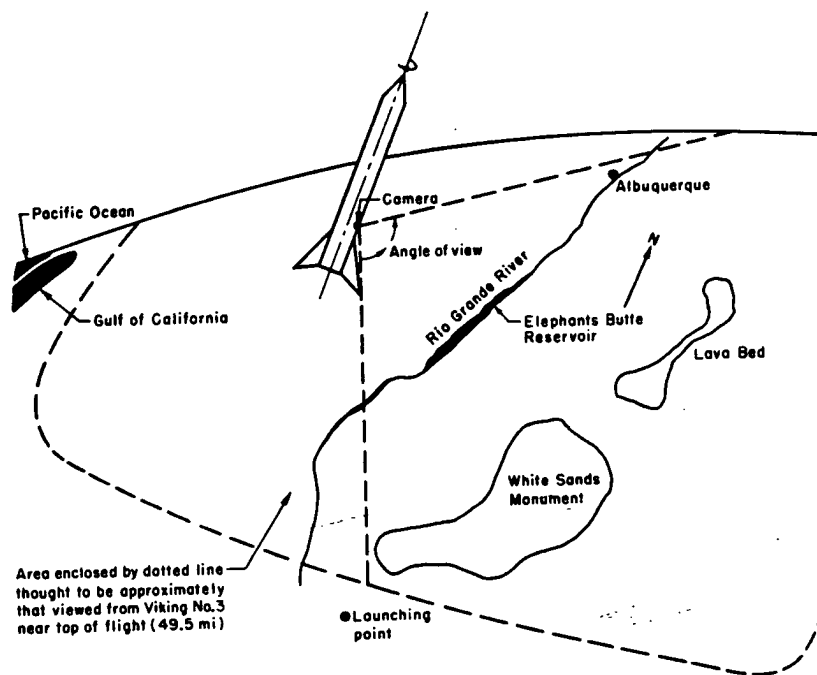

Fig. 5—Schematic representation of viewing area from rocket camera

a line of convergence may lie in the west and northwest section of the photographic area. As a result of the peculiar orientation of the cloud sequence, viz., cirriform clouds in the foreground in the west and northwest with thicker clouds in the background, one is led to believe that this line of convergence extends from the northwest and west down toward the southern border of the United States.

Winds. Despite the fact that no direct observations of the winds (from clouds) were available because of the poor photographic conditions, estimates can be made from the synoptic situation.

In the presence of a frontal condition as estimated above, the winds to the east of this supposed line of convergence should be southwesterly to southeasterly, depending on the distance from this line. The wind in the vertical should be primarily from the same direction. To the west of the line of convergence, the winds would be expected to be west or northwest in the lower layers.

Temperature. Taking into account the analyzed weather picture, estimates of the direction of temperature gradients were made, and the results are plotted on Fig. 6.

Results of the Analysis. The results of this analysis are presented in Fig. 6, and the actual conditions are shown in Fig. 7.

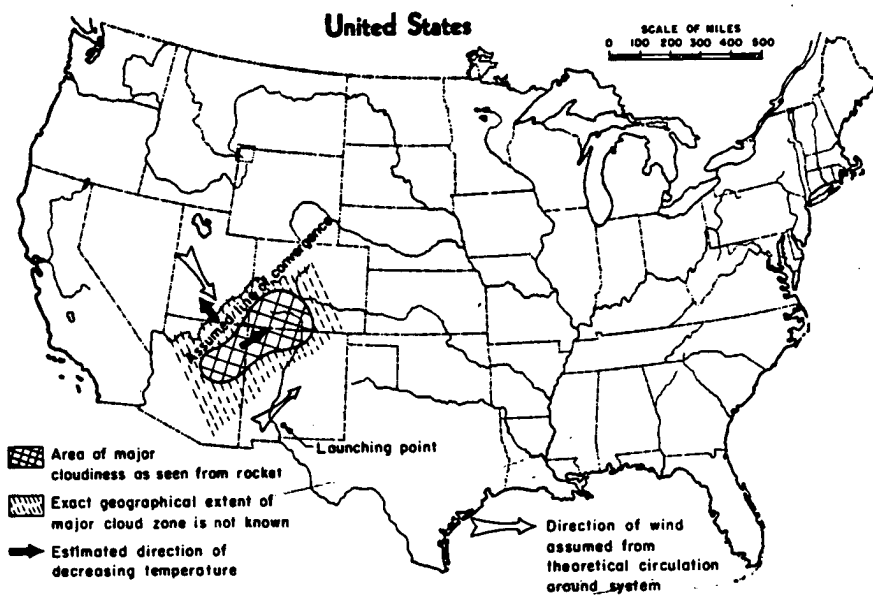

Fig. 6—Synoptic situation as estimated from Viking No. 3 photographs, February 9, 1950

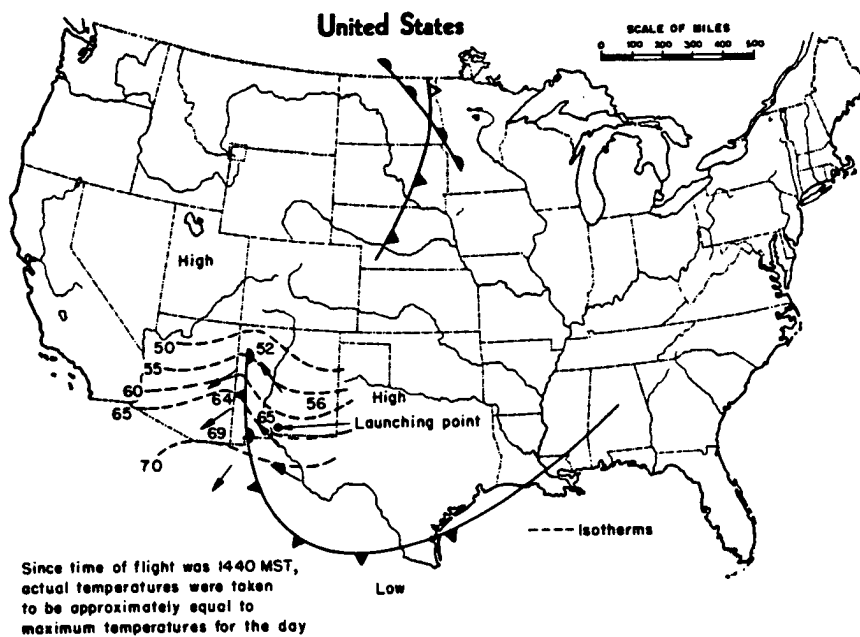

Fig. 7—Actual weather situation from weather map for February 9, 1950, 1330 EST

V-2 NO. 28 (AFCL)

Date of firing.....	Dec. 8, 1947
Time of firing.....	1440 MST
Peak altitude.....	63 mi

What Was Observed

Films were very clear, and data were available from two cameras located in different parts of the rocket. Details such as landmarks, roads, airfields, and towns were partially identifiable, and the general tilt of the rocket and the scope of the photographic sweep were ascertained. The over-all cloud picture is as follows:

To the west and west-northwest lies a very extensive layer of altostratus. To the east of this layer and in the immediate west and northwest foreground can be seen patches of cumulus and stratocumulus. This layer stretches completely to the horizon in the northwest (approximately 500-700 mi) and either this or an adjoining sheet of clouds can be seen on the horizon in north and north-northeast quadrants. The area within 75- to 100-mi radius of the launching site is almost completely clear of clouds. Various widely separate cloud elements (cumulus, lenticular clouds) can be seen throughout the camera sweep in other directions but they appear to be caused by local or topographic conditions.

Synoptic Situation—Preliminary Estimate

As in the previous example, it appears that an area or line of convergence or upslope motion lies quite far to the west and northwest of the launching area (approximately 500 mi). The position of the area of complete clearness and the estimated position of the line of convergence suggest that the low-level flow in the foreground region is from the south and southwest. To the north and northeast, the layer of clouds that appears on the horizon seems to be of a very thin nature (cirrostratus or thin altostratus).

Temperature. As in the previous case, directions of temperature gradients were estimated to fit the existing situation and are plotted on Fig. 8.

Results of the Analysis. The estimated and actual situations appear in Figs. 8 and 9, respectively (page 28).

AEROBEE A-7 AND V-2 NO. 40

On July 26, 1948, two rockets were fired approximately one hour apart. The unusual quality and quantity of clear photographs obtained from these firings merit their mention in this report. At first glance there appears to be no occurrence of great meteorological interest, but on closer inspection a clear picture of synoptic interest becomes evident.

Aerobee A-7

Date of firing.....	July 26, 1948
Time of firing.....	0947 MST
Peak altitude.....	70 mi
Time to peak.....	189 sec

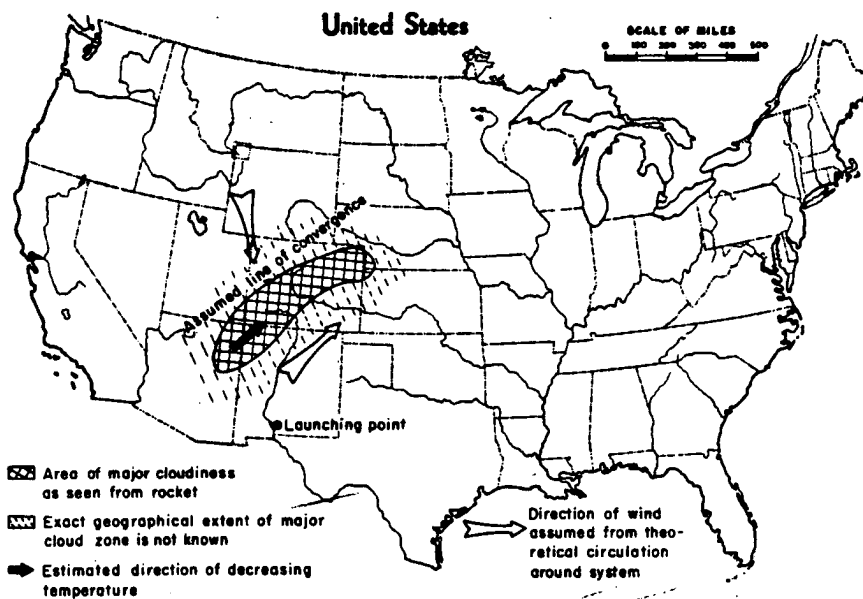

Fig. 8—Estimated synoptic situation from V-2 No. 28, December 8, 1947

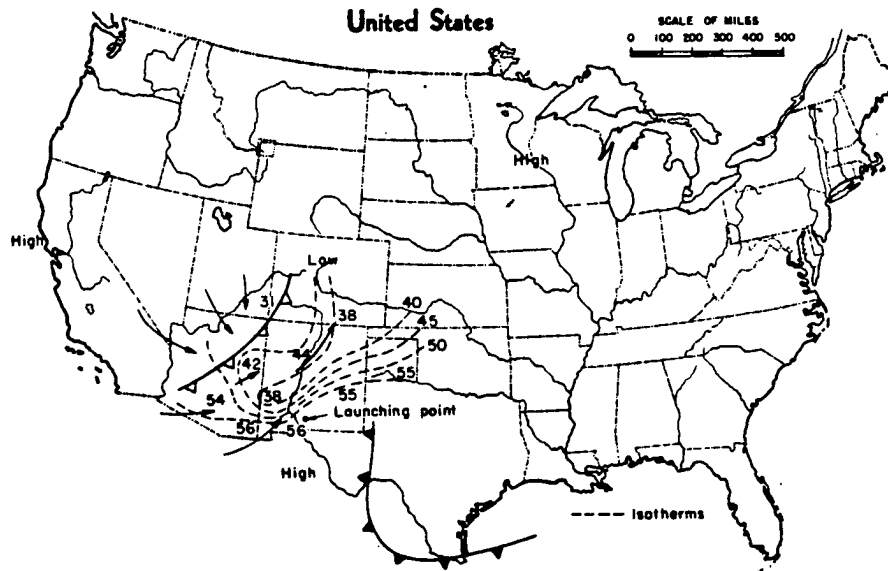

Fig. 9—Actual synoptic situation from surface map for December 8, 1947, 1330 EST

V-2 No. 40

Date of firing.....	July 26, 1948
Time of firing.....	1103 MST
Peak altitude.....	60.3 mi
Time to peak.....	205 sec

Due to the close proximity of the two flights their data are considered as one unit.

What Was Observed

To the north can be seen scattered cumulus and cumulonimbus over the mountains, with a deck of altostratus or altocumulus in the distance, just south of Albuquerque and spreading west as far as Flagstaff, Arizona (this appears to be a possible line of convergence and may indicate the leading edge of a front at that level, 10,000-15,000 ft). To the immediate east lies a relatively clear area, while to the northeast and background east can be seen further evidence of an altostratus cloud deck. This appears to indicate that this possible line of convergence may be discontinuous to the immediate east, appearing again several hundred miles further east. To the southeast can be seen occasional patches of stratus and altostratus, indicating possible low-level flow from the Gulf of Mexico. There is a widespread cloud cover to the south and southwest (Mexico) which consists of altostratus and stratocumulus, cumulus and cumulonimbus being seen over the mountains. To the west there is considerable cumulonimbus activity, with what appears to be a large deck of cirrostratus covering part of Arizona. The towering cumulonimbus in the west and southwest appear to slope toward the north and northwest, and those in the south appear to slope toward the west. This, combined with the "torn-off" direction of the tops, seems to indicate that the upper-wind direction is from the south, southeast, and east, respectively. Over the mountain range immediately to the northeast of the launching site, small cumulus clouds can be seen streaming from the peak tops in an east-northeasterly direction, indicating that winds at that level (10,000 ft) are from the west-southwest.

Synoptic Situation Analysis

There appears to be no major low-pressure center, except possibly to the northeast out of range of the photographs and associated with the apparent line of convergence to the north of the launching site. From the apparent directions of the wind (deduced from clouds), one possible analysis of the situation is that a large high-pressure area covers most of the southwest (Arizona, New Mexico, etc.) in the upper layers (20,000 ft), while in the lower layers (4000-10,000 ft) the center of this high is shifted east. From the amount of cloudiness to the south and southwest and the apparent direction of the wind in that quadrant, there is a possible indication of a warm, moist tongue of air advancing from the southeast and recurving back to the north and east. Directions of temperature gradients are estimated by using the shear as indicated by the slope of the cumulonimbus clouds (this method has been explained previously). The results of this analysis are presented in Fig. 10, and the actual synoptic picture is shown in Appendix I.

As indicated previously, only the photographs were used in performing this analysis. In an effort to associate weather parameters and features more closely with those visible

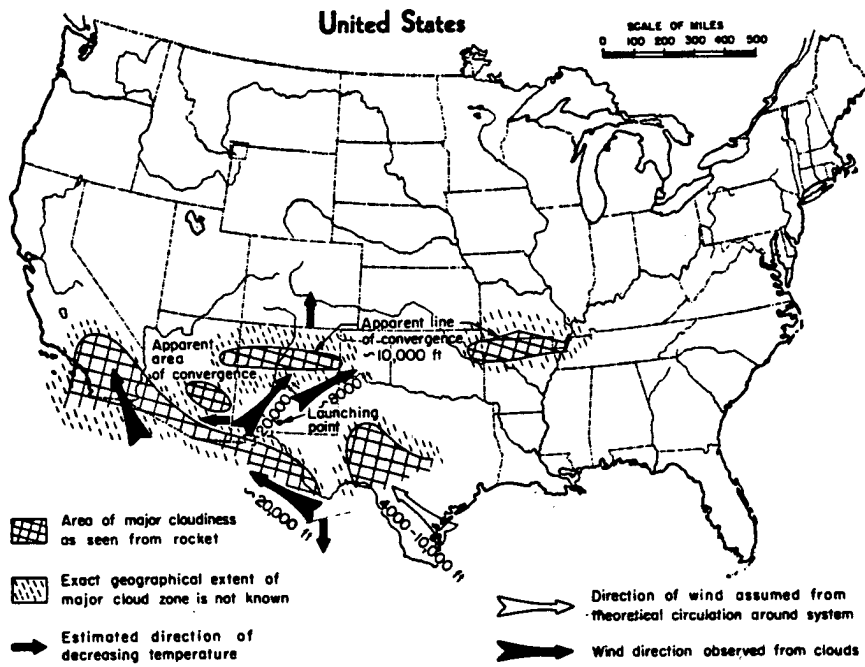

Fig. 10—Estimated synoptic picture from V-2 No. 40 and Aerobee A-7, July 26, 1948

in a rocket photograph, Professor J. Bjerknes, of the University of California at Los Angeles, has reanalyzed the flights of July 26, 1948, using all the synoptic information available. His results are presented in Appendix I. Also included in Appendix I is an illustrative mosaic of the actual photographs taken on these two flights.

COMMENTS ON THE PRECEDING ANALYSES

Although some of the discrepancies in the analyses may be explained by the difficulty usually encountered in locating fronts in mountainous terrain, it is obvious that much more than a simple look at a cloud photograph is needed. It is not necessary to elaborate on these needs, as the suggested methods of satisfying them have been discussed in the previous sections. However, one can easily see how applications of such items as perimeter weather, etc., to these attempted analyses would have greatly improved the final results. The reader should also keep in mind the fact that each observation was made from a vertically fired rocket, and its field of view was, therefore, comparatively limited. In the case of the satellite this limitation would be partially removed.

Several interesting things are to be observed from these analyses, such as the following: (1) The fact that by simply using the analyzed circulation (both theoretical and observed) and a knowledge of regional climatology, one was able to obtain good estimates

of the actual temperature-gradient direction; and (2), that these photographs would be of considerable assistance to normal means of forecasting. It was noticed, for example, that in photographs from the three latter rocket flights one was able to see a layer of cirrus clouds in the distance (denoting convergence aloft) that later (within 12 to 24 hr) resulted in regions of widespread precipitation.

Obviously many more photographs of rocket flights exist than have been analyzed here. However, for various reasons it was not possible to perform a full analysis on a great majority of them. All the available photographs are listed in Appendix II, showing their degree of usefulness to this study.

CONCLUSION

In the section entitled "What Can Be Seen," page 3, it was shown that, given at least 500-ft resolution, it was possible to differentiate between the various types of clouds. Under "Limitations of the Analysis," page 13, the possible limitations to the type of analysis to be studied were indicated. Given the identity of virtually all the cloud forms viewed, it was further shown, in the section entitled "What Can Be Determined from High-Altitude Observations," page 14, that it may be possible to estimate the various meteorological parameters under certain conditions and assumptions. The main assumption was that some estimate of the over-all synoptic situation could be made initially and a "hunting" technique could be applied. Several suggested methods of estimating the synoptic picture were presented and discussed.

This report has attempted to show what is thought to be necessary in the making of such an analysis. It is obvious, however, that, with the limited data available, many important points may inadvertently have been overlooked. An inquiry of this type can therefore serve only as a guide to a full-scale study of the subject, in which every suggestion and method is put to a full test and is either accepted, modified, or discarded.

The development of all the suggested methods mentioned in this report appears to be feasible. As any analysis depends on its integral parts for its accomplishment, from this standpoint, if from no other, the analysis of synoptic weather from satellite observations is also feasible.

APPENDIX I

**DETAILED ANALYSIS OF SYNOPTIC WEATHER AS OBSERVED
FROM PHOTOGRAPHS TAKEN ON TWO ROCKET FLIGHTS
OVER WHITE SANDS, NEW MEXICO,
JULY 26, 1948**

BY J. BJERKNES

*Department of Meteorology, University of California
at Los Angeles*

THE FRONTAL CLOUDS

In the composite picture from the highest altitude of V-2 No. 40, a strip of flat cloud (actually altostratus and altocumulus) can be seen in the northwest quadrant, extending from the Rio Grande 300 mi west to Flagstaff, Arizona. That cloud strip can be identified as being the remnant cloud of the trailing end of a cold front from the cyclone, north of the Great Lakes in Fig. 11. The outline of the main areas of alto cloud and cirrus cloud as seen from the highest levels of the rocket flights has been entered on the map in this figure.

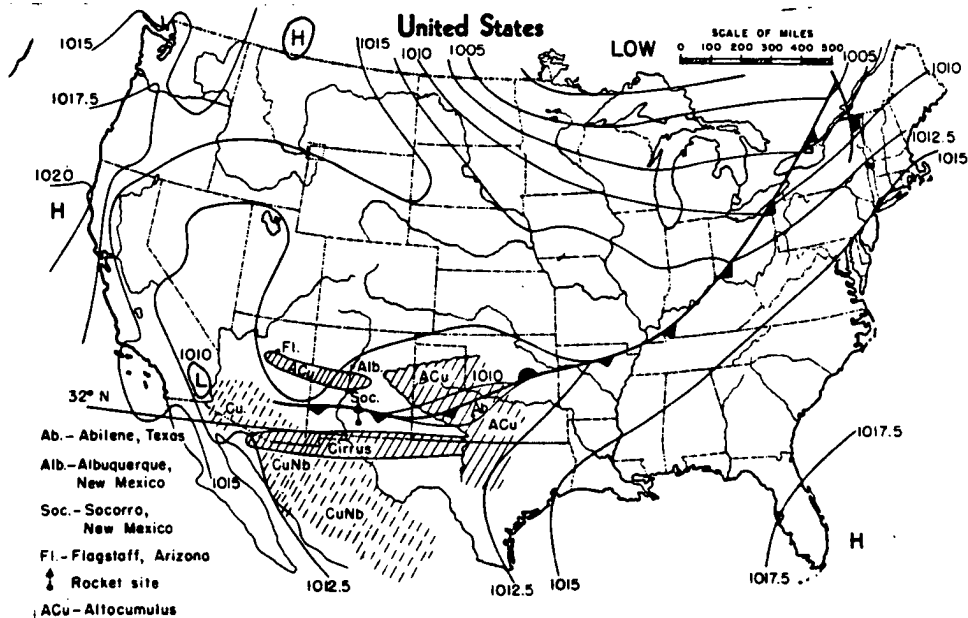

Fig. 11—Surface weather map for July 26, 1948, 1130 MST

In the Rio Grande valley, the southern sharp edge of the alto cloud sheet is located near Socorro, New Mexico, while the more irregular northern edge lies about 50 mi farther upriver in the region south of Albuquerque, New Mexico. The front cloud is thin, shows holes and cracks at many places, and does not seem to give any frontal precipitation. Nevertheless, the strip of frontal cloud marks an important air-mass limit between subsident polar air to the north and partly thundery tropical air to the south.

Presumably also of frontal origin are the cirrus clouds, which can be seen to extend in a zone near the Mexican border parallel to the strip of altostratus-altocumulus. The zone of cirrus seems to come to an end over southwestern Arizona.

For the reader with access to the complete sequence of pictures taken from the Aerobee (firing time 9:47 A.M., MST) and the V-2 (11:03 A.M., MST) the detailed description of the frontal-cloud cirrus, altocumulus, and altostratus on pages 40 through 42 may be useful. The study of the pictures from low altitude in conjunction with those from the higher altitude is a help toward the right interpretation of the unfamiliar look of clouds from 60 to 70 miles elevation.

The distribution of the frontal cloud, viz., altocumulus, altostratus, and cirrus, can be understood from an inspection of the maps of upper winds in Fig. 12. The line of convergence, marking the front, goes through New Mexico on the 14,000-ft map just where the strip of alto cloud is seen on the composite photograph in Fig. 13. While there is a general afflux of tropical air to the line of convergence at 8000 ft, the flow picture is more complicated south of the front at 14,000 ft, owing to the splitting up of the subtropical high into two cells, one over northern Mexico and one over the Mexican Gulf. West of the Mexican high, the tropical air continues to flow toward the front, thus keeping the strip of alto cloud, from Flagstaff, Arizona, to the Rio Grande, narrow and well defined. Farther east, the tropical air partly branches off southward around the Mexican high, and what there is available of frontal cloud will be thinning out and spreading over a large area (such as that shown by the northeast-quadrant pictures).

The cirrus zone through southern Arizona and New Mexico lies along a line of convergence between northerly and easterly winds on the 30,000-ft map. This line of convergence at 30,000 ft is not the same as that shown at 14,000 ft between the cold high over Utah and the warm high over northern Mexico. Already, at 18,000 ft (not reproduced), the cold high has disappeared, and, farther up, the warm high is found to tilt northwestward so as to be centered over northwestern New Mexico at 30,000 ft. The origin of the cirrus probably must be sought over the front a day or two earlier, when it must have had the usual high build-up of cloud typical of rainy fronts. The light northerly winds to the east of the 30,000-ft high-pressure center must have separated the cirrus from the stagnating frontal altocumulus strip over northern New Mexico and herded them into the zone of convergence between northerlies and easterlies at the Mexican border. The westward views therefore show the cirrus and altocumulus in two parallel zones separated by a 150-to-200-mile-wide cloudless space. The eastward views, on the other hand, cover an area where, in the distance, the altocumulus is drifting southward as "prefrontal cloud" with about the same forward edge as that of the cirrus.

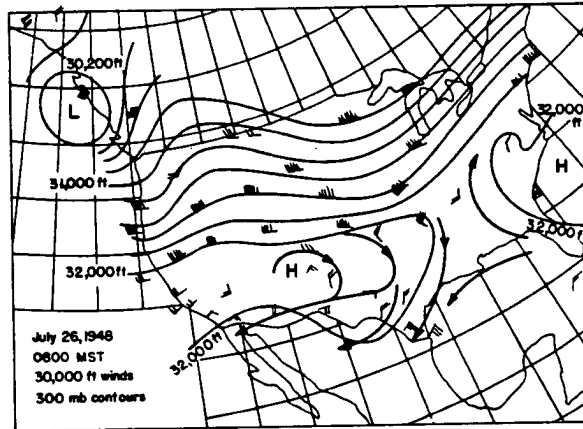
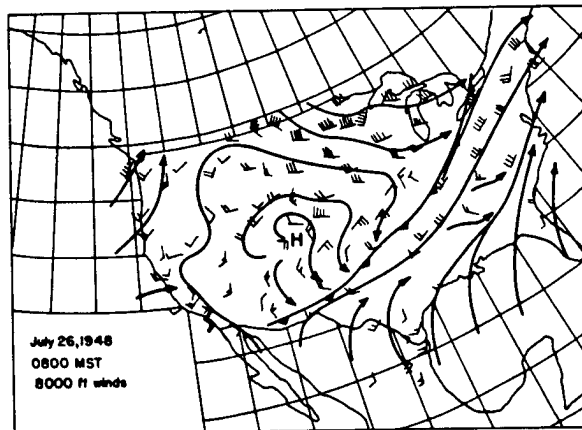
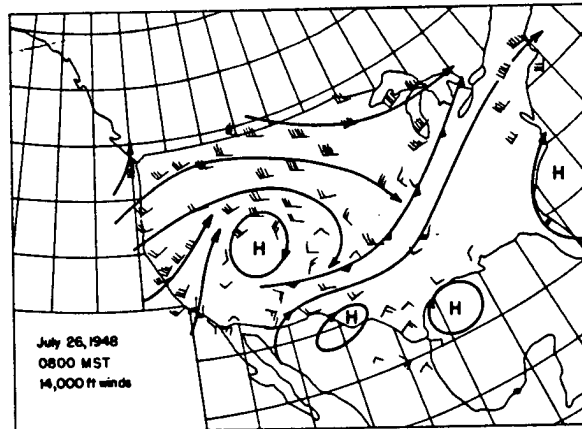

Fig. 12—Selected upper-air wind maps



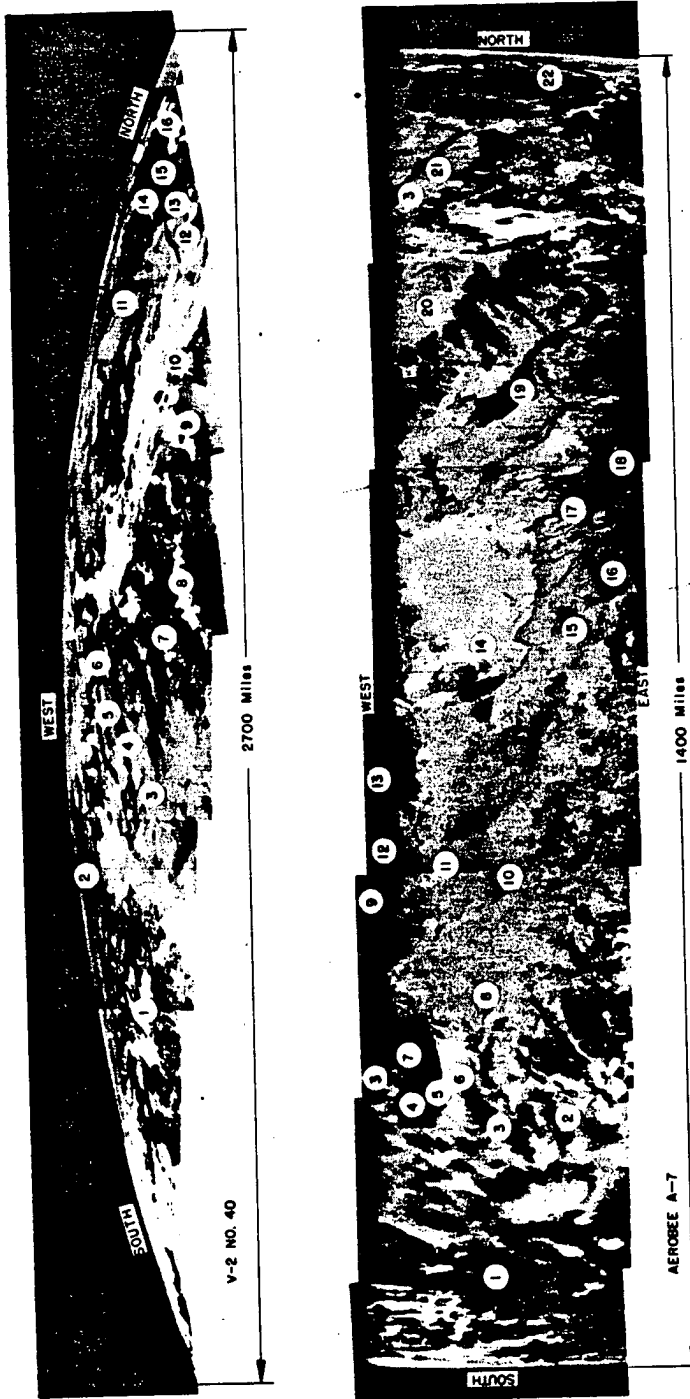

Fig. 13—Composite photographs taken from V-2 and Aerobee rocket flights on July 26, 1948

Composite picture covering the southwest and northwest quadrant, as seen from the V-2 near 60 mi elevation (about 11:05 A.M., MST, July 26, 1948), and another composite picture covering a north-to-south strip from Wyoming to Mexico, as seen from the Aerobee near 70 mi elevation (about 9:50 A.M., MST, same day). Official U.S. Navy-Johns Hopkins University (API) photograph.

Identification numbers in the upper composite (V-2) are, as follows: (1) Mexico; (2) Gulf of California; (3) Lordsburg, New Mexico; (4) Peloncillo Mountains; (5) Gila River; (6) San Carlos Reservoir; (7) Mogollon Mountains; (8) Black Range; (9) San Mateo Mountains; (10) Magdalena Mountains; (11) Mount Taylor; (12) Albuquerque, New Mexico; (13) Sandia Mountains; (14) Valle Grande Mountains; (15) Rio Grande River; and (16) Sangre De Cristo Range.

Identification numbers in the lower composite (Aerobee) are as follows: (1) Mexico; (2) Texas; (3) Rio Grande River (note that this is indicated in three places); (4) Ciudad Juarez, Mexico; (5) El Paso, Texas; (6) Biggs Field Army Air Base; (7) Franklin Mountains; (8) Southern Pacific railroad, with highway alongside; (9) Organ Mountains; (10) Tularosa Basin; (11) V-2 and Aerobee launching sites; (12) Base Headquarters, White Sands Proving Grounds, New Mexico; (13) San Andres Mountains; (14) White Sands National Monument area; (15) Alamogordo Army Air Field; (16) Alamogordo, New Mexico; (17) Tularosa, New Mexico; (18) Sacramento Mountains; (19) Malpais, or ancient lava beds; (20) test site for the first atomic bomb; (21) Albuquerque, New Mexico; and (22) areas of Wyoming.

THE AIR-MASS CLOUDS

The cumuli and cumulonimbi are easy to recognize from any rocket elevation. They form preferably over mountain ranges, whereas the large desert flats remained cloudless at the time of the rocket flights. There is quite a noticeable growth of all-cumuliform cloud in the interval between the taking of the Aerobee pictures (9:47 A.M.) and the V-2 pictures (11:03 A.M.). Of particular interest is the different cloud growth in the polar air north of the front and the tropical air to its south and also the different cumuliform activity in the various parts of the tropical air.

The cumuli north of the front are rather flat, even where they feed on the thermal convection over the 14,000-ft peaks of the Rockies north of Durango, Colo. No anvils are to be seen over the entire area north of the front. South of the front there are several cumulonimbi, and the cumuli show a tendency toward narrow tower formation (most clearly seen in the southwest horizon), which may have led to anvil forms later in the day. The strongest convective activity is seen over Mexico and the western edge of the Arizona plateau from the border to Flagstaff. Scattered thundershowers were reported over that area at 1130 MST and more general thunderstorms at 1730 MST. No cumulonimbi can be seen, and no thunderstorms were reported during the day over the low-lying western part of Arizona and what can be seen of California beyond. New Mexico has towering cumuli and a few cumulonimbi over the mountain ranges close to the front, but the greater part of the state south of the front is cloudless apart from the band of cirrus along the Mexican border (which may hide some cumulus underneath). In the eastern skies, cumulus activity is very sparse. No cumulus heads are seen to pierce the altocumulus level, except at great distance eastward. That local development can probably be identified with the showers reported at Abilene and Fort Worth, Texas (400 to 500 miles away), later in the day. The southeast quadrant, which is free of altocumulus and cirrus, except for the nearby area, shows only small and scattered cumuli. No showers occurred in that direction during the day.

The great variation of cloudiness and cloud form along a west-to-east profile (Fig. 14) south of the front can be understood as the result of the "cell structure" of the subtropical belt of high pressures. Farthest west, the Pacific anticyclone is in its normal position over the ocean; a warm continental anticyclone can be seen in the maps of upper winds from 10,000 ft upward, with its axis tilting from western Texas at 10,000 ft to northwestern New Mexico at 30,000 ft. Finally, a third anticyclone is located in low layers over the Gulf of Mexico. The air of the Pacific anticyclone forms a shallow cold wedge invading the California coastal strip, and the air of the Gulf anticyclone forms a deeper, moderately cold wedge covering most of Texas. Between the two cold wedges, the "continental tropical air" of the middle anticyclone occupies widening space with increasing elevation.

The low cloud of the Pacific anticyclone is known to be only of stratus type. Above the stratus, the air is kept very dry through sinking. The air of the western end of the Gulf anticyclone lies in a wedge shape under that of the warm continental anticyclone. The sloping boundary surface between the two air masses (both tropical) is at the same

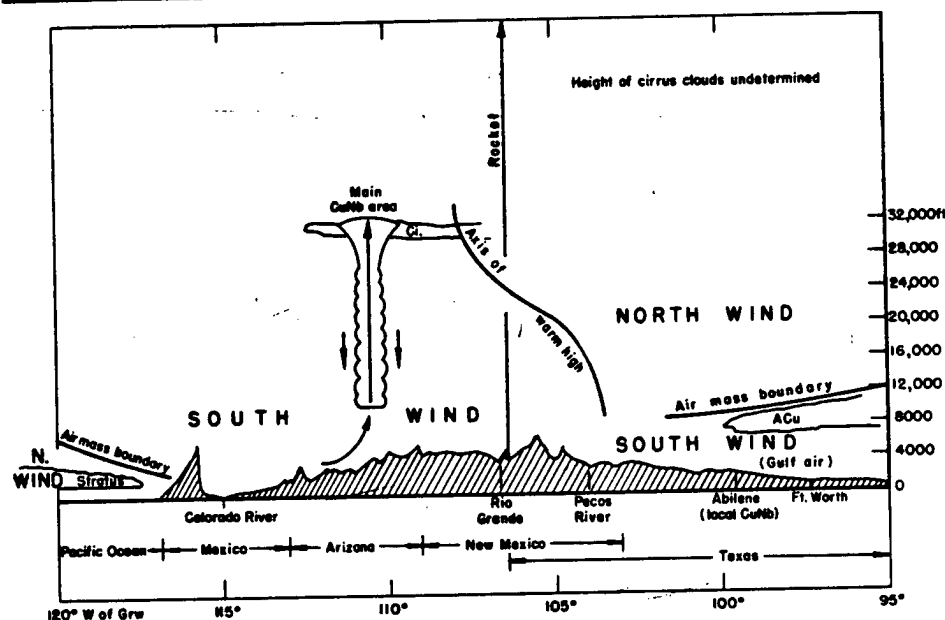
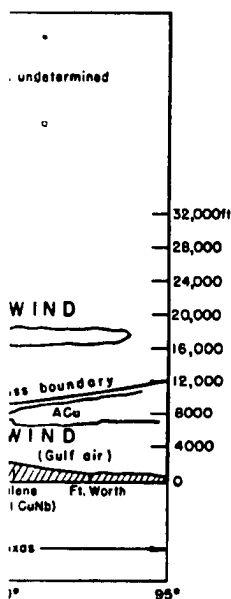

Fig. 14—Profile along 32°N

time characterized by the change from southerly winds below to northerly winds above. That feature in the wind field is found at 14,000 ft at the Texas coast and tilts down toward 8000 ft in the region of the highlands of western Texas and northern Mexico. The air space below that tilting surface of discontinuity is above freezing temperature, so that even at the Texas coast no complete anvil-capped shower clouds can form. Looking toward the Gulf anticyclone from the rocket (to the right of the eastward cirrus on the pictures) very few cumuli are seen, and they are all of moderate size, as can be expected from Fig. 14.

The middle anticyclone cell in Fig. 14, being warmer than those to the west and east, occupies widening space with height, and the cumulus towers in that space are not hindered in their growth by air-mass boundaries. All the high-reaching cumuliform clouds seen from the rocket belong to that warmest subtropical cell of high pressure. The greatest density of cumuliform cloud is observed over the northern Mexican highlands, where moist tropical air from the south is injected below the level at which the warm anticyclone begins to appear (see the 8000-ft map in Fig. 12). From that main region of cumulus activity, a narrow branch of high-reaching cumuliform cloud extends along the mountain ranges at the western edge of the Sonora and Arizona high plateau (a favorable region for convection, because of slope circulations between the western lowlands and the high plateau). Farther east, inside the same anticyclone (southern New Mexico), the cumulus activity is weak or absent. This is probably owing to the fact that the lower levels have been invaded by polar air (see the 8000-ft map, Fig. 12).

Right along the frontal strip of alto cloud from Flagstaff to the Rio Grande, the convective activity is favored and breaks through the alto level to form anvil tops. The



ertherly winds above.
coast and tilts down
nd northern Mexico.
reezing temperature,
er clouds can form.
f the eastward cirrus
oderate size, as can

ose to the west and
in that space are not
g cumuliform clouds
high pressure. The
Mexican highlands,
at which the warm
om that main region
cloud extends along
ona high plateau (a
en the western low-
lone (southern New
wing to the fact that
p, Fig. 12).

he Rio Grande, the
orm anvil tops. The

more diffuse continuation of the front east of the Rio Grande is not associated with any cumulonimbus formation for several hundred miles. The distant cumulonimbus formation toward Abilene, Texas, is probably at the front or just to the south of it. The converging flow at 8000 ft (Fig. 12) in that region seems to justify the cumulonimbus formation there.

The tilt of cumuli can be seen to indicate an increase of westerlies with height in the polar air toward the far northern edge of the cloud panorama. The shape of the cumuli closer to the north side of the front indicates very light winds and little change of wind with height. South of the front, the cumuli drift from the west and dissolve downwind from the mountain ranges over which they were formed. The tilt of the Arizona cumulonimbi shows a slight increase of southerlies with height, and the anvils of the cumulonimbi over Mexico, due south of the rocket, show increasing easterlies with height. These wind shears observed through cloud tilts would indicate temperature decrease both northward, westward, and southward from the rocket side. This is corroborated by the radiosonde temperatures in the middle and upper troposphere measured in the morning and in the evening of the launching day. Actually, the launching took place in a warm upper anticyclone, Big Springs, Texas, being the warmest place at 300 mb with a -27°C . From the center of the upper warm high, the cumulonimbi in all directions should be seen to tilt toward the right. The distant cumulonimbi due east do not reveal any definite tilt, but apparently they are located only a very little east of the warmest point.

SUMMARY

In summary, it may be said that the rocket pictures add a considerable amount of interesting information to the ordinary weather-map analysis, and, in addition, that the accumulated knowledge from the maps helps us in the new problem of interpreting what we see from high-level rocket pictures. The question as to how much of the synoptic picture can be derived from the rocket photographs alone has been treated in the main body of the report. It may be added that although, in the present report, the ordinary surface and upper-wind maps had to be used to a great extent to arrive at the total picture, accumulated experience from several analyses by joint rocket and conventional methods would make it possible to arrive at the right analysis by rocket pictures only.

The rocket pictures will certainly show all fronts quite well. The front discussed in this report was a very weak one, but its existence is clearly revealed by the "frontal arrangement" of alto and cirrus clouds over several hundred miles. Repeated pictures at 24-hr intervals or less over wide areas would in most cases establish the continuity in time and space of each front almost as well as is done by consecutive weather maps. Some difficulties may be anticipated when the background for the upper cloud is not so dark as that provided by the earth. If the ground is covered with new snow, fog, or uniform low sheet clouds (stratus), it may at times be difficult to discern the pattern of medium and upper cloud against the background of equal whiteness. However, it can be expected that this white background will never be entirely devoid of a structure

pattern of its own which would present some contrast to the upper cloud. Moreover, the shadow of upper cloud thrown upon the lower cloud would certainly help to give a stereoscopic view of the frontal cloud systems.

The wind direction at ground level would be well shown by the smoke from cities or from isolated big factories. The wind at the cumulus level can be observed clearly over hilly country, where the hills are source regions for trails of downwind cumuli. Over entirely flat country, that type of wind observation might fail; but the tilt of individual cumuli would show the direction of the shear of the wind, which, in low levels, would show the direction of the wind itself after correction with the known relationships between wind and wind shear in the friction layer. Where there are cumulonimbi the wind-shear observations are available up to about 30,000 ft, and these give the very useful indication of the direction of the horizontal temperature gradient (90° to the left of the wind-shear vector in the northern hemisphere). In the usual middle-latitude pictures, the wind shears would be much stronger and easier to observe than in the case considered in this report and would mainly point out the normal tropospheric decrease of temperature poleward. Deviations from that due northward direction of the horizontal temperature gradient would show the location of cold and warm tongues, which is one important feature of the three-dimensional synoptic picture.

The everlasting shortcoming of the synoptic analysis by rocket pictures alone lies in the fact that no quantitative picture of the pressure field is obtained. Only indirect, and very uncertain, guesses can be made regarding the depth of low-pressure centers and the change with height of the horizontal pressure gradient (from the wind shears). But even in this problem, accumulated experience might help. The observable change from an open-front wave to an occluded vortex (in a time succession of pictures) would tell about the intensification of the corresponding low-pressure center and its growth up to the higher layers. Or, as another example, the "steering" of a small cyclone by the circulation system of a larger one may be synthesized from a coverage of pictures in time and space. The implication concerning the pressure field should then be that the cyclone providing the center of steering must be a cold-core one having a greater depth of its pressure center in higher layers, whereas the steered cyclone should be a warm-core shallow one having a moderate present pressure minimum with potentialities for deepening.

A detailed description of the cirrus and the alto cloud as seen on Aerobee pictures (9:47 A.M., MST) and V-2 pictures (11:03 A.M., MST) is as follows:

CIRRUS CLOUDS—SEEN FROM VARIOUS ELEVATIONS

A good view of the cirrus from below is afforded by the Aerobee pictures 3, 4, and 5 (westward), 10 and 11 (eastward), 12 and 13 (southward), and 14, 15, and 16 (westward). There is no cirrus in the northern sky. The next eastward views in 21 and south-eastward in 22 show patches of altocumulus under the rocket level, the cirrus still being above. The following pictures, 23 through 27, show the traversing of the cirrus level in views changing slowly from southwest to west-northwest. The cirrus has a flat top.

Pictures 28 through 34 (northwestward) show some small patches of distant cirrus imbedded in haze. With a temporary rocket spin opposite to that observed in the beginning of the flight, pictures 36 through 40 give westward views of nearby dense cirrus seen from above. Next, the views change back from west past north to east, where the eastward part of the cirrus zone is now seen from above in pictures 46 through 58. The haze horizon, which presumably marks the tropopause, is still well above the cirrus. In pictures 59 and 60, the next southeastward views toward the sun, the haze horizon is sharp and probably not far from the level of the rocket. The eastward and nearby part of the cirrus zone can also be seen in pictures 72, 73, 74, 86, 99, 100, 113, 114, 127, 128, 141, 142, 143, 156, 157, 170, 171, 184, 185, 198, 199, 212, 213, 230, 231, and 232, but no westward view is available because of the orientation of the rocket.

In the V-2 pictures, the cirrus begins to appear on picture 20 at the left edge of the west-northwest oriented view. Pictures 35, 36, and 37 are oriented more due west and show more of the cirrus, still extending from the left edge. The following pictures turn more northward, away from the cirrus. In 56 through 60, the cirrus zone to the eastward is seen, already below the rocket level. In 91 through 94, a corresponding view of the westward part of the cirrus zone is seen, very much like the composite view from the maximum altitude. The nearby and distant parts of the western cirrus are seen again in 117 through 121, 146 through 149, 174 through 178, and 201 through 208, and the eastern cirrus is seen in 215 through 219 and 227, 228, and 229 (end of film).

There is a noticeable difference in the apparent whiteness of the eastward and westward cirrus when seen from above. With the sun in the southeastern quadrant, the cirrus in the east offers a better light reflection than that in the west. The cirrus toward the sun is as white as the water clouds (altocumulus and cumulus) below, whereas the cirrus in the west appears greyish in comparison with them.

ALTOCUMULUS AND ALTOSTRATUS—SEEN FROM VARIOUS ELEVATIONS

In the Aerobee pictures looking northward, across White Sands, the frontal strip of altocumulus can be faintly seen through the haze in pictures 8, 18, and 19. In 21 and 22 there are nearby patches of altocumulus below the rocket. In the northwestward views of 30 through 35, some distant patchy altocumulus is seen, which must belong to the front. The same appears more clearly in 41 through 44. East of the Rio Grande, in 44 and 45, the altocumulus is also found, but in small, patchy sheets. In the east-northeast view, in 46, altocumulus sheets are seen in the distant left and cirrus in the near right. The same sweep along the frontal altocumulus from west past north to east-northeast is seen in 53 through 58, 66 through 72, and 80 through 85. With increasing height of the rocket, extensive distant sheets of altocumulus appear toward the east and northeast (85), at one place toward the east pierced by cumulus heads. The higher pictures from the Aerobee add nothing essential to the above survey of alto clouds.

The first frontal alto cloud in the V-2 pictures become visible behind the cumulus of the Black Range on picture 30 but disappear, owing to the turn of the rocket, after 36.

They reappear on 38, where a cumulonimbus is also seen to pierce the flat sheet of altocumulus at the right edge of the photograph. The same cumulonimbus is seen in 48 and 49. The altocumulus now extends across the Rio Grande, where it had a break in the Aerobee pictures 5/4 hr before. The continuous altocumulus belt now ends 50 miles east of the Rio Grande, and toward the northeast only distant altocumulus can be seen. The northeastward view from higher levels, in pictures 79, 80, 129, 130, 158 through 160, 186, 187, 188, and 223 through 228, shows widely scattered altocumulus but in less amount than on the Aerobee pictures. The cumulus head piercing the altocumulus on Aerobee picture 85 has developed a large anvil (center of V-2 picture 226).

In contrast to the unorganized, widely scattered altocumulus in the northeast quadrant, there is an orderly arrangement of altocumulus and altostratus in the northwest quadrant along that part of the front extending west of the Rio Grande.

APPENDIX II
FILMS AVAILABLE FOR THIS STUDY

Rocket from Which Films Were Taken	Date and Time of Firing	Size and Amount of Film	Maximum Altitude of Missile	Remarks
V-2 No. 20	Feb. 20, 1947 Time: 1117 MST	16 mm, 50 ft	65 mi	Shows action of parachute. Good cloud pictures, but not enough to make analysis.
V-2 No. 28	Dec. 8, 1947 Time: 1440 MST	16 mm, 50 ft 35 mm, 100 ft 35 mm, 50 ft	63 mi	Good cloud pictures. excellent orientation possible. Analysis attempted.
V-2 No. 31	Dec. 8, 1949 Time: 1217 MST	16 mm, 50 ft	81 mi	Fired preceding bad frontal condition. Intermittent frames give evidence of extensive cloud cover. Not enough to orient with respect to ground or to give other necessary information. No analysis attempted.
V-2 No. 40	July 26, 1948 Time: 1103 MST	4 × 5-in. print; 100-ft roll	60.5 mi	Good cloud pictures. excellent orientation possible. Analysis attempted.
Aerobee A-7	July 26, 1948 Time: 0947 MST	4 × 5-in. print; 100-ft roll	70 mi	Good cloud pictures. excellent orientation possible. Analysis attempted.
V-2 No. 56	Nov. 18, 1949 Time: 0905 MST	16 mm, 100 ft	76.85 mi	Excellent pictures. However, the complete lack of clouds within useful range of camera prohibits an analysis.
Viking No. 3 (NRL)	Feb. 9, 1950 Time: 1444 MST	4¼ × 5¾-in. prints; approx. 300-ft roll	49.5 mi	Film very foggy. From various features observable in photographs, an estimate of the orientation was made and an analysis was attempted.

FOR OFFICIAL USE ONLY