

File Power

MODERN OFFICE BUILDINGS UTILITIES ALTERNATIVES

PROJECT #9433
STATUS REVIEW



12 JANUARY, 1982

STAT

TRW
DEFENSE AND SPACE SYSTEMS GROUP

TOPICS

- BACKGROUND
 - PROJECT FLOW AND SCHEDULE
 - NARROWING OF OPTIONS TO POINT-OF-DEPARTURE

- P.O.D. ELECTRIC POWER SUBSYSTEM
 - BASIC APPROACH
 - DESCRIPTION
 - AVAILABILITY

- P.O.D. ENERGY / ECS SUBSYSTEM
 - LOAD PATTERNS
 - ENERGY FLOWS
 - ENERGY FLOWS / ON-SITE GENERATION

- FURTHER EFFORTS

PROJECT 9433

MODERN OFFICE BUILDING UTILITIES ALTERNATIVES

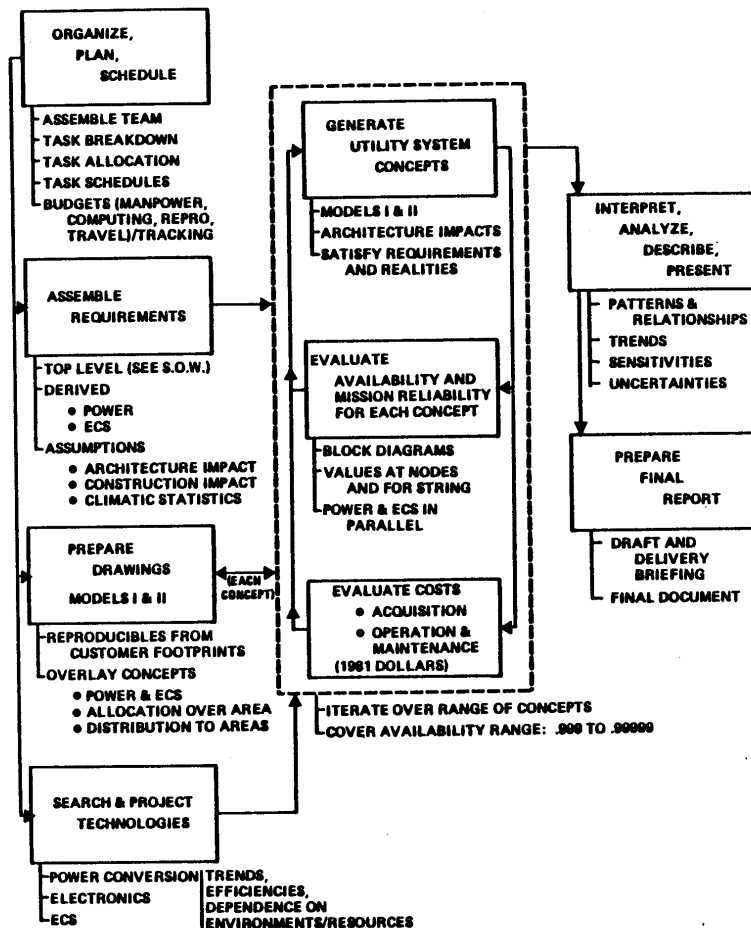

SUMMARY TASK PLANNING SHEET

LEGEND	START MILESTONE DATE	ACTIVITY PERIOD	END MILESTONE DATE
PLAN	▲	▬	▽
CHANGED	▲	▬	▽
COMPLETE	▲	▬	▽

SALES NO.	PROJECT TITLE
9433	MODERN OFFICE BUILDING UTILITIES ALTERNATIVES
DESIGN NO. TITLE	
SUMMARY TASK	TITLE

ORIG. DATE	PWA REF. NO.	PAGE	OF
21 OCT 81		1	1
RESPONSIBLE INDIVIDUAL	REF. CCC		
F. FARRINGTON	6862		
UPDATE STATUS DATE			

NO.	SUBTASK DESCRIPTION	SUMMARY TASK OVERALL SCHEDULE												APPROVALS	DATE	FUNCTIONAL MANAGER	PROJECT MANAGER												
		OCT 16	OCT 23	OCT 30	NOV 6	NOV 13	NOV 20	NOV 27	DEC 4	DEC 11	DEC 18	DEC 25	JAN 1					JAN 8	JAN 15	JAN 22	JAN 29	FEB 5	FEB 12	FEB 19	FEB 26	MAR 5	MAR 12	MAR 19	MAR 26
1	PREPARE TASK PLANS AND SCHEDULES	[Gantt bar from Oct 16 to Oct 23]																											
2	PREPARE BUILDING ENVELOPE DRAWINGS AND UTILITIES AS CONCEIVED	[Gantt bar from Oct 23 to Nov 6]																											
3	ASSEMBLE REQUIREMENTS	[Gantt bar from Nov 6 to Nov 13]																											
4	TECHNOLOGY RESEARCH AND PROJECTIONS	[Gantt bar from Nov 13 to Dec 4]																											
5	DEFINE UTILITY SYSTEM CONCEPTS	[Gantt bar from Dec 4 to Dec 18]																											
6	EVALUATE AVAILABILITY FOR CONCEPTS	[Gantt bar from Dec 18 to Dec 25]																											
7	EVALUATE COSTS FOR CONCEPTS	[Gantt bar from Dec 25 to Jan 1]																											
8	INTERPRETATION, ANALYSIS, DESCRIPTIONS, PRESENTATION	[Gantt bar from Jan 1 to Jan 15]																											
9	PREPARE FINAL REPORT	[Gantt bar from Jan 15 to Jan 22]																											
10	CLIENT CONFERENCE	[Gantt bar from Jan 22 to Jan 29]																											
TOTAL DIRECT RESOURCES																													
DIRECT LABOR DOLLARS/HOURS																													
DIRECT MATERIAL DOLLARS																													
DIRECT ODC DOLLARS																													

VALUE METHOD
P = COMPLETE
S = SUBSIDIARY SYSTEM
COMPLETION EVENT

TYPE
L - LABOR
M - MATERIAL/SUBCONTRACT
S - ODC

NARROWING OF OPTIONS TO POINT--OF-DEPARTURE

- PROTECTION OF CRITICAL POWER
 - TRANSFORMERS
 - MOTOR-GENERATOR SETS
 - UPS**
 - ACTIVE, REDUNDANT ON-SITE GENERATION
- ON-SITE POWER GENERATION
 - DIESELS
 - GAS TURBINES**
 - STEAM TURBINES
- ECS DISTRIBUTION
 - CIRCULATE WATER; AHU'S IN ZONES
 - SAME, BUT DEDICATE VERY-LOCAL AHU'S TO COMPUTER LOADS**
 - CIRCULATE CENTRALLY-TREATED AIR
- ECS GENERATION
 - CENTRIFUGAL CHILLERS**
 - ABSORPTION CHILLERS
 - ICE-MAKER HEAT PUMPS
 - ANNUAL CYCLE ENERGY STORAGE
 - HEAT SINK
 - COOLING TOWERS**
 - COOLING PONDS
 - AQUIFERS (SEE ACES)
 - MINOR UTILITY FUNCTIONS
 - DOMESTIC HOT WATER
 - SOLID WASTE
 - SEWAGE
 - M.I.U.S. APPROACH

**THESE OPTIONS SELECTED FOR POINT OF DEPARTURE



BASIC APPROACH TO DESIGN

I. THREE SEPARATE BUS LOADS

A. CRITICAL LOAD – MAIN FRAME COMPUTERS ONLY *EMW*

B. ESSENTIAL LOAD *11 MW*

1. UPS AIR CONDITIONERS
2. COMPUTER AIR CONDITIONERS
3. 50% BUILDING GENERAL LOADS

- a. LIGHTS
- b. MINI COMPUTERS
- c. BUILDING ESSENTIAL SERVICES

C. NORMAL BUILDING LOADS – CAN BE DOWN WITH NO EFFECTS ON TASK *EMW*

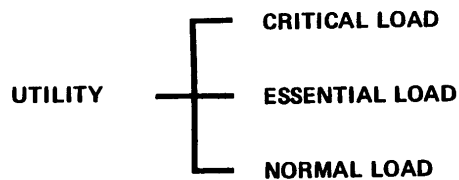

II. CRITICAL LOADS

A. SIX (6) UPS SYSTEMS

1. 3 - 60 HZ
2. 3 - 415 HZ

B. LOCATE IN BASEMENT TO SHORTEN RUNS TO COMPUTERS:

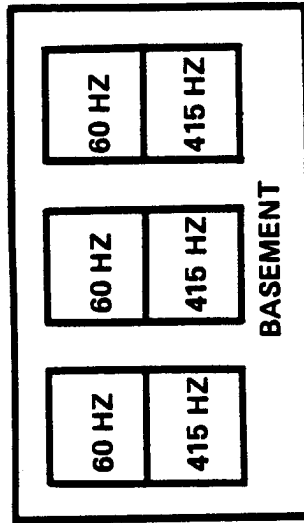

C. FIVE MINUTE UPS BATTERY

D. GENERATOR BACKUP (STANDBY)

E. REDUNDANT UPS SYSTEMS

1. MAX. MODULE LOAD -
 - a. 80% RATING FOR 5 MODULE SYSTEM
 - b. 75% RATING FOR 4 MODULE SYSTEM
 2. ALLOWS PREVENTATIVE MAINTENANCE ON UPS SYSTEM MODULES
- F. STANDARD OR WIDELY USED MODULES SELECTED**

III. ESSENTIAL LOAD

- A. WILL BE LOST FOR 2-3 MINUTES FOLLOWING AN OUTAGE**
- B. GENERATOR BACKUP REQUIRED**
- C. THREE RUNS UP TO EACH FLOOR FOR BUILDING GENERAL LOADS**

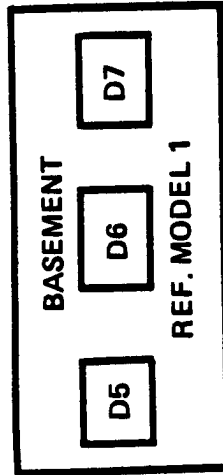

IV. NORMAL LOADS

- A. NO GENERATOR BACKUP REQUIRED**
- B. TWO RUNS TO EACH FLOOR**

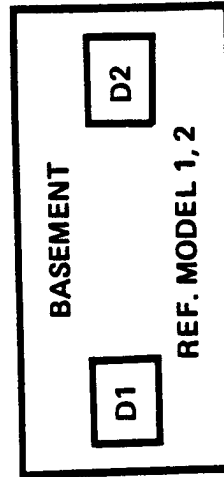

POINT-OF-DEPARTURE SIMPLIFIED SINGLE LINE

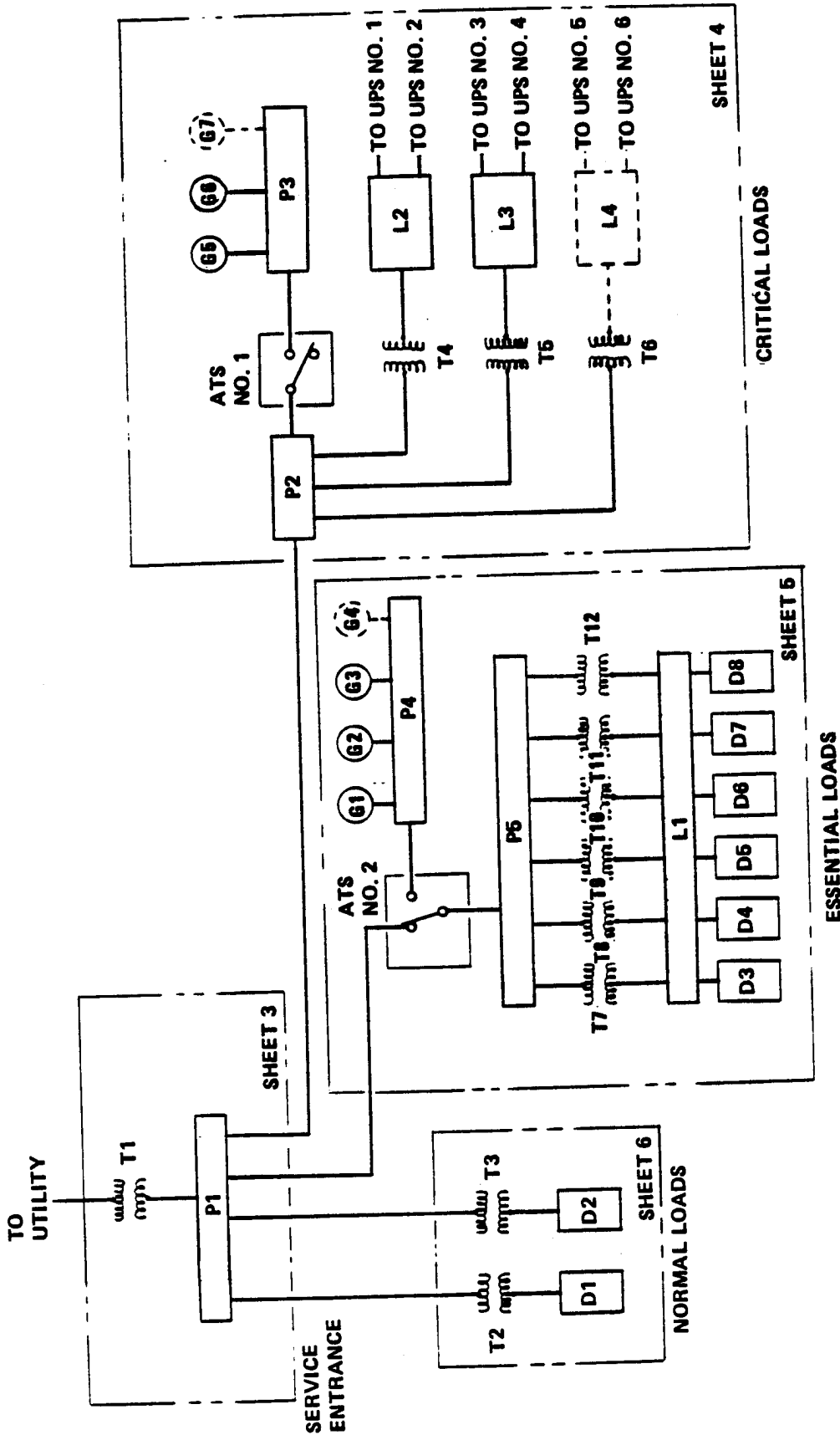

PANEL KEY:
 P: 4160 VAC DISTRIBUTION PANEL
 L: 480 VAC DISTRIBUTION PANEL
 D: 480 VAC DISTRIBUTION PANEL



CRITICAL LOAD DISTRIBUTION

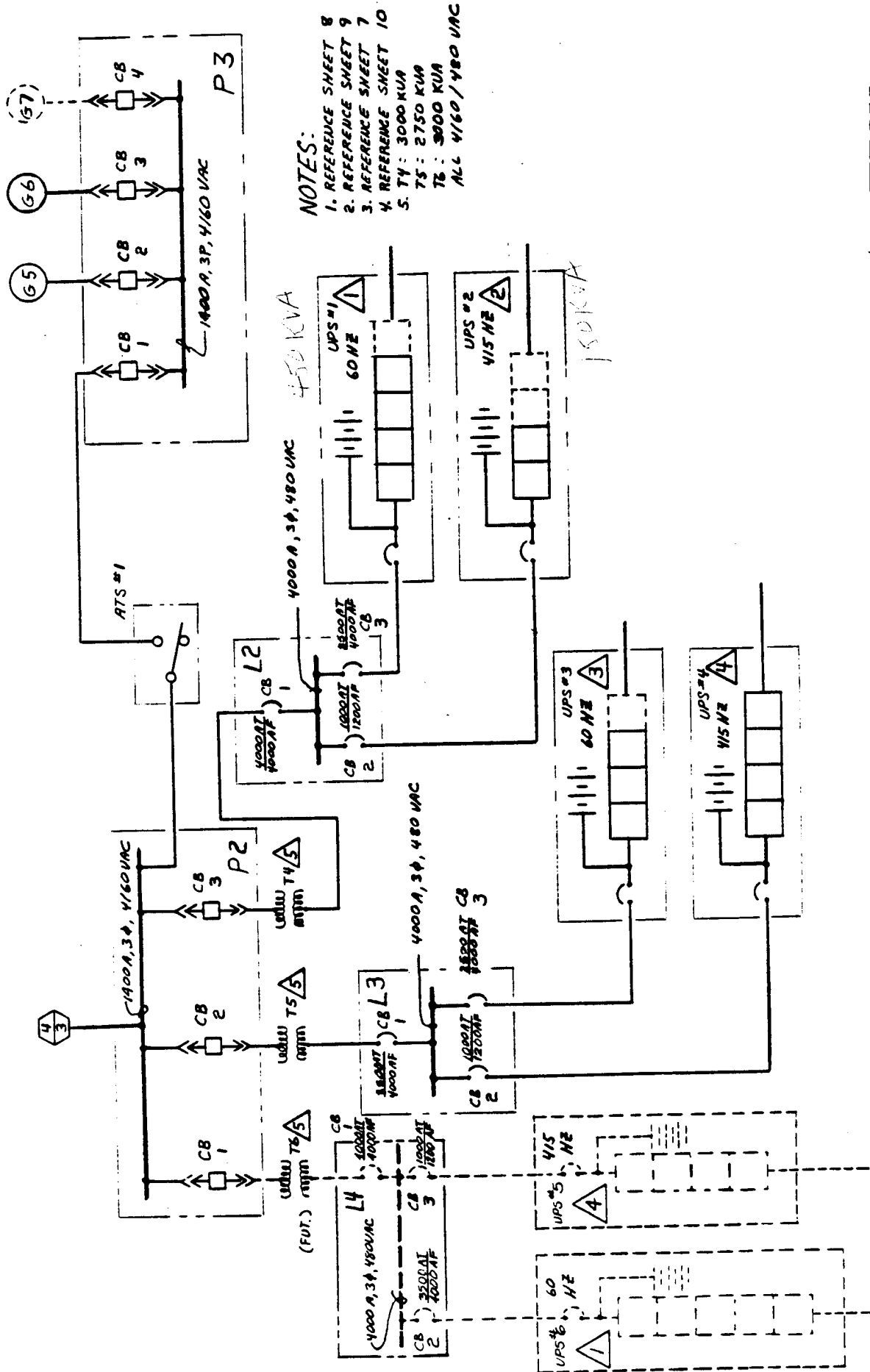

15

TYPICAL UPS SYSTEM

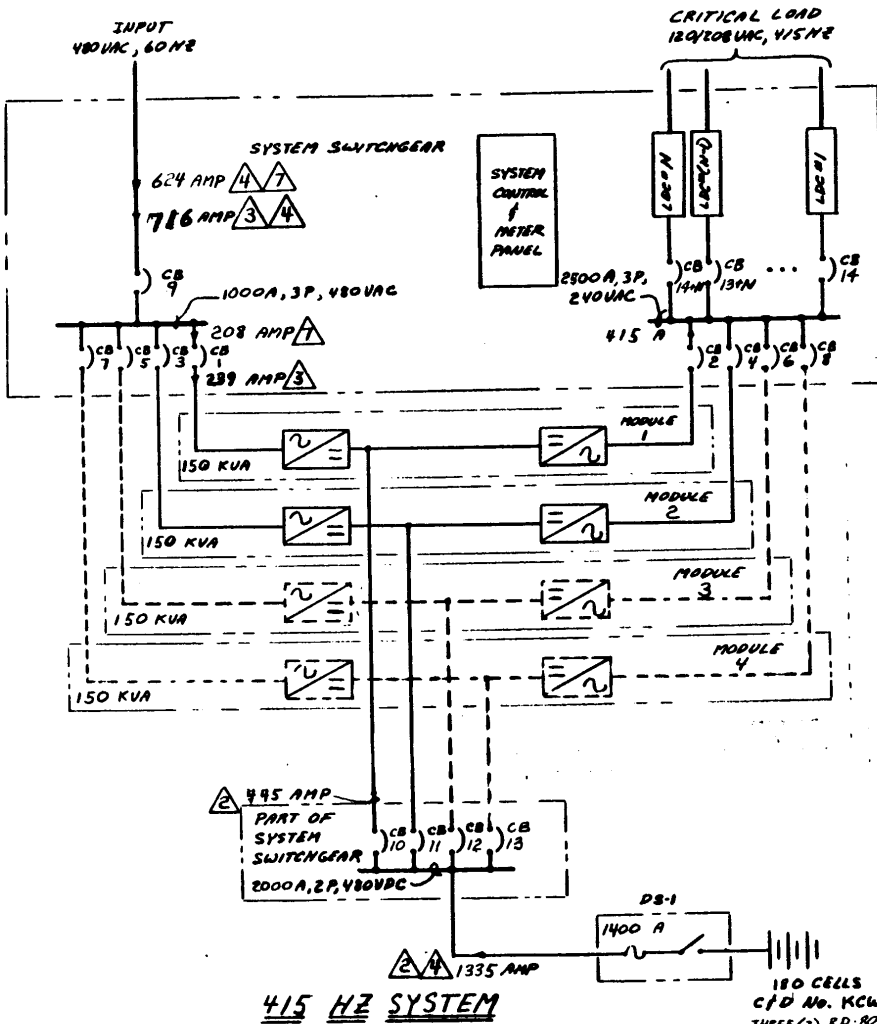

CIRCUIT BREAKERS

SYMBOL	DESCRIPTION	RATING & ACCESSORIES
CB9	MAIN INPUT BREAKER	1000AT 1200AF, 3 POLE, 600VAC, 60HZ
CB1, CB3, CB5, CB7	MODULE INPUT BREAKERS	300AT 400AF, 3 POLE, 600VAC, 60HZ
CB2, CB4, CB6, CB8	MODULE OUTPUT BREAKERS	500AT 600AF, 3 POLE, 240VAC, CALIBRATE FOR 415 HZ
CB10, CB11, CB12, CB13	MODULE BATTERY DISCONNECT	100AT 100AF, 2 POLE, 480VDC
CB14 : : CB(14IN)	LDC INPUT BREAKER	SIZE TO BE DETERMINED BY COMPUTER SYSTEM, 3 POLE, 240 VAC, CALIBRATE FOR 415 HZ, BELL ALARM
DS 1	MAIN BATTERY DISCONNECT	2000AMP FRAME, 2 POLE, 480 VDC

NOTES:

1. SYSTEM RATING
INITIAL - 150 KVA
EXPANDED - 450 KVA
2. AT LOW BATTERY VOLTAGE
3. RATE FOR DISCHARGED BATTERIES
4. RATE FOR EXPANDED SYSTEM.
5. ALL BREAKERS ALSO INCLUDE:
24 VDC SHUNT TRIP
2ABB AUX. CONTACTS.
6. ALL MODULE EXHAUST FANS TO BE 415 HZ.
7. BATTERY AT FLOAT VOLTAGE.



ESSENTIAL LOAD DISTRIBUTION

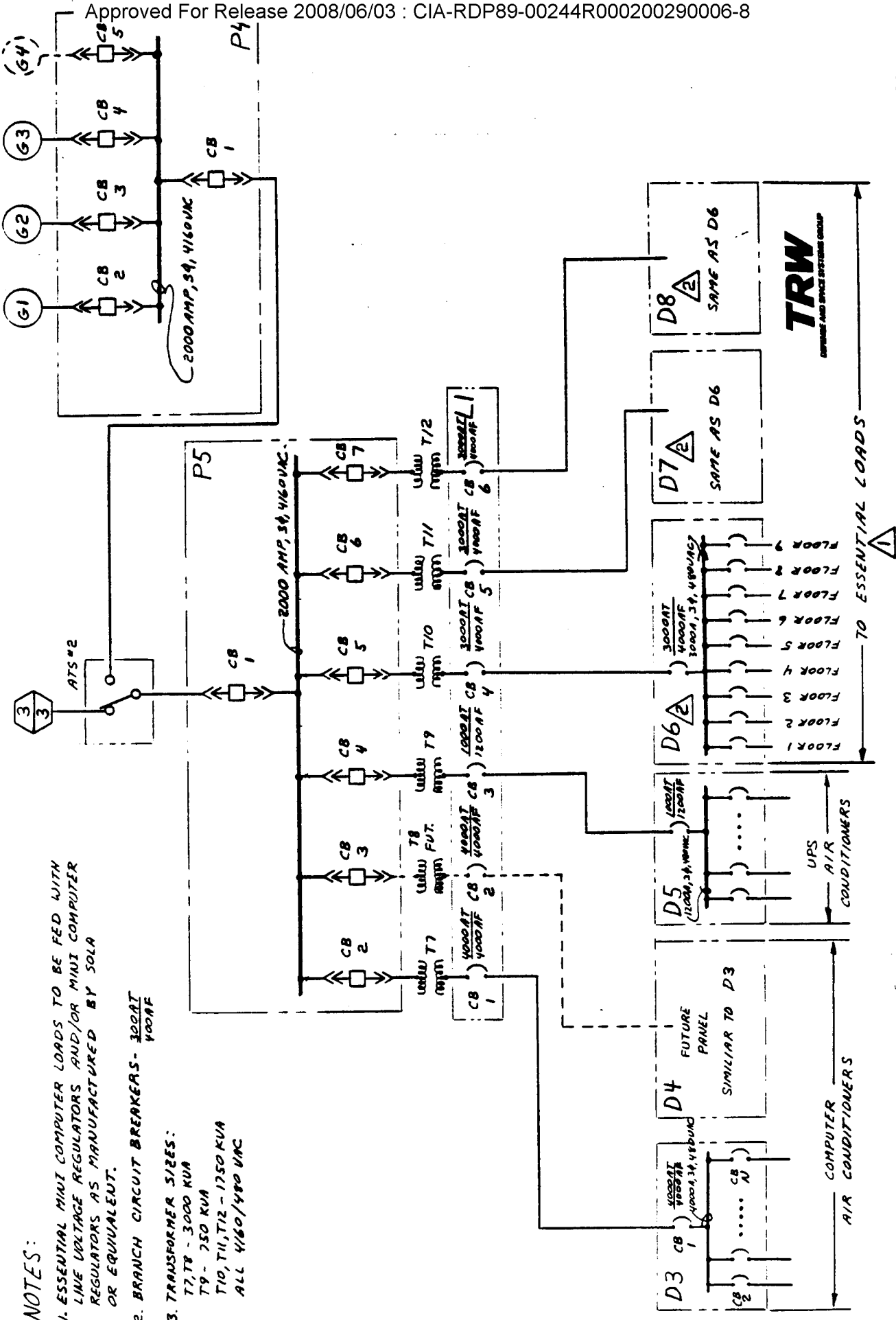

NOTES:

1. ESSENTIAL MINI COMPUTER LOADS TO BE FED WITH LINE VOLTAGE REGULATORS AND/OR MINI COMPUTER REGULATORS AS MANUFACTURED BY SOLA OR EQUIVALENT.
2. BRANCH CIRCUIT BREAKERS - 300AT 400AF
3. TRANSFORMER SIZES:
 T7, T8 - 3000 KVA
 T9 - 250 KVA
 T10, T11, T12 - 1750 KVA
 ALL 4160/480 VAC

UPS AVAILABILITY BLOCK DIAGRAM (BATTERIES SEPARATE)

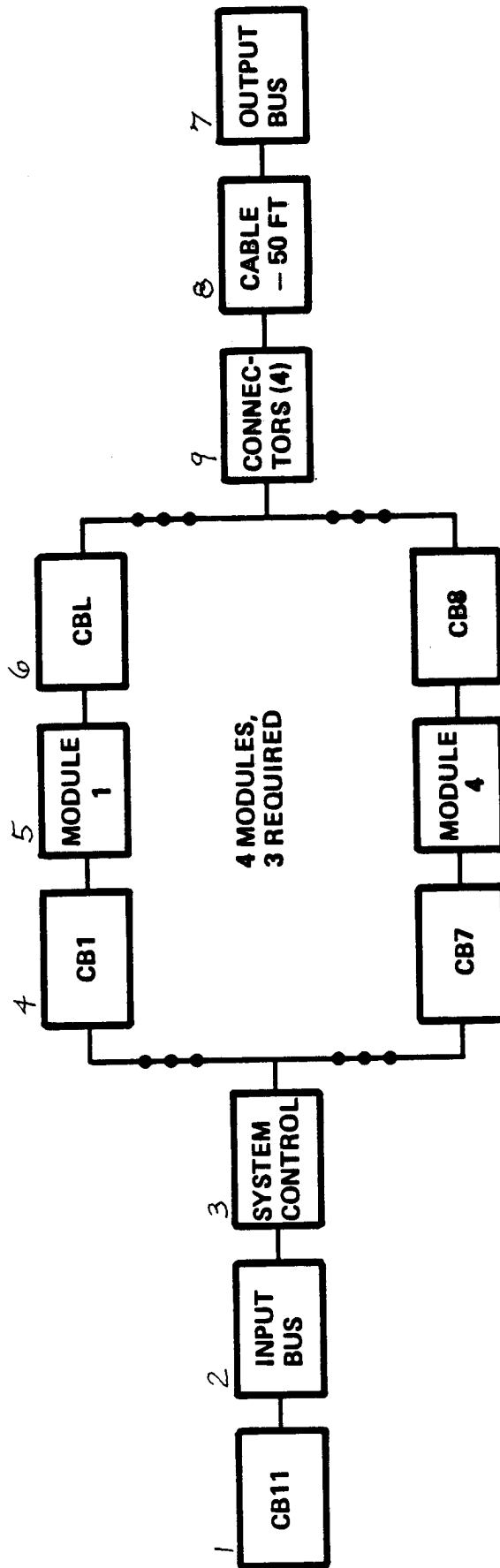

MATHEMATICAL MODEL:

$$A = A_1 A_2 A_3 [(A_4 A_5 A_6)^4 + 4(A_4 A_5 A_6)^3 (1 - A_4 A_5 A_6)] A_7 A_8 A_9^4 = 0.99997$$

POINT-OF-DEPARTURE AVAILABILITY SUMMARY (PRELIMINARY)

SUBSYSTEM	AVAILABILITY
SERVICE ENTRANCE	0.99996
CRITICAL LOADS	
DISTRIBUTION BREAKERS	
UPS NO. 1	0.99999
UPS NO. 2	0.99995
UPS NO. 3	0.99986
UPS NO. 4	0.99997
UPS NO. 5	0.99986
UPS NO. 6	0.99986
UPS SUBSYSTEM	0.99995
BATTERY NETWORK	0.99951
GENERATORS' TURBINE	0.99978
GENERATORS' DIESEL	0.97894
	0.93228
ESSENTIAL LOADS	
ESSENTIAL LOAD	0.99995
E.L. GENERATORS, TURBINE	0.97230
E.L. GENERATORS, DIESEL	0.91363



CRITICAL LOAD SYSTEM AVAILABILITY BLOCK DIAGRAM

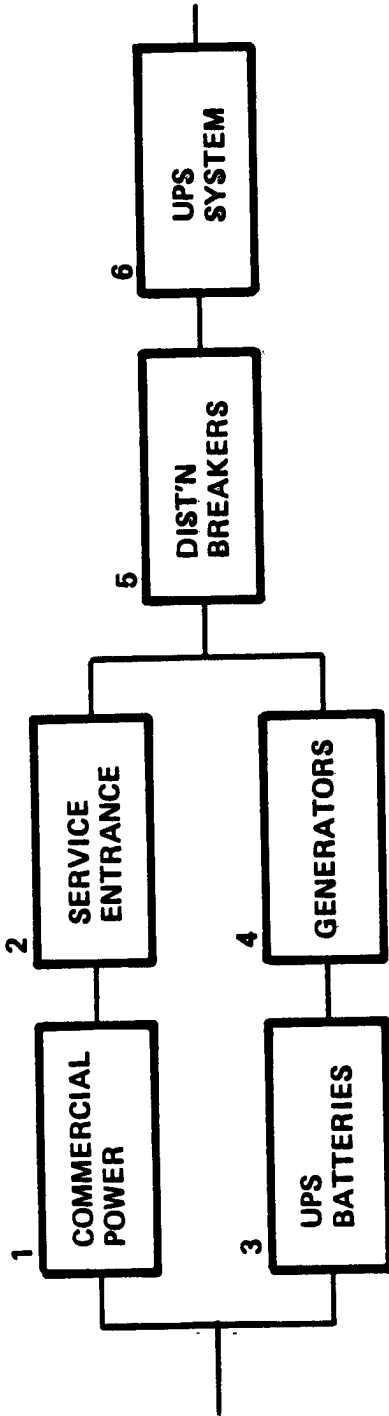

MATHEMATICAL MODEL:

$$A = [1 - (1 - A_1 A_2)(1 - A_3 A_4)] A_5 A_6$$

GENERATOR TYPE	1	2	3	4	5	6	SYSTEM
	COMMERCIAL POWER	SERVICE ENTRANCE	UPS BATTERY	C.L. GENERATORS	C.L. DIST'N BREAKERS	UPS SYSTEMS	
DIESEL	0.990	0.99996	0.99978	0.93228	0.99999	0.99951	0.99881
	0.995	0.99996	0.99978	0.93228	0.99999	0.99951	0.99916
	0.999	0.99996	0.99978	0.93228	0.99999	0.99951	0.99943
TURBINE	0.990	0.99996	0.99978	0.97804	0.98999	0.99951	0.99928
	0.995	0.99996	0.99978	0.97804	0.98999	0.99951	0.99939
	0.999	0.99996	0.99978	0.97804	0.98999	0.99951	0.99948



ESSENTIAL LOAD SYSTEM AVAILABILITY BLOCK DIAGRAM

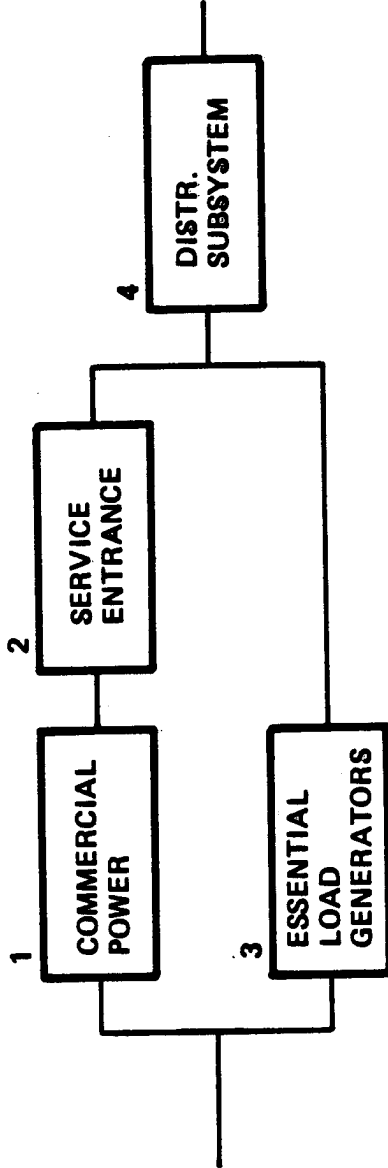

MATHEMATICAL MODEL:

$$A = [1 - (1 - A_1 A_2)(1 - A_3)] A_4$$

	1	2	3	4	
GENERATOR TYPE	COMMERCIAL POWER	SERVICE ENTRANCE	GENERATORS	DISTR. SUBSYSTEM	E.L. SYSTEM
DIESEL	0.990	0.99996	0.91363	0.99995	0.99998
	0.995	0.99996	0.91363	0.99995	0.99961
	0.999	0.99996	0.91363	0.99995	0.99986
TURBINE	0.990	0.99996	0.97230	0.99995	0.99967
	0.995	0.99996	0.97230	0.99995	0.99981
	0.999	0.99996	0.97230	0.99995	0.99992

TRW
DEFENSE AND SPACE SYSTEMS GROUP

COOLING LOAD PATTERN

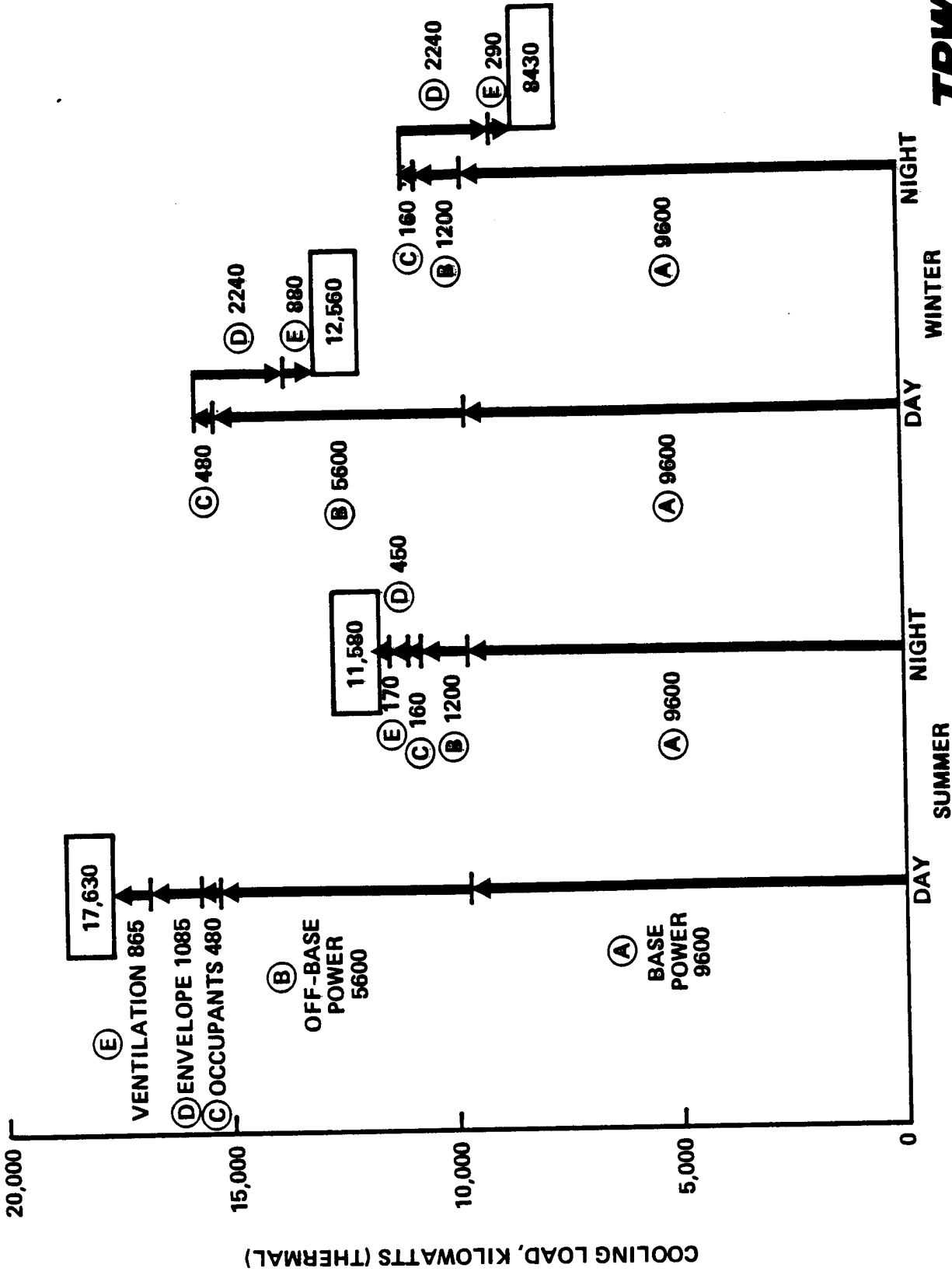

ENERGY FLOWS

POINT OF DEPARTURE/CONVENTIONAL (ALL ENERGY VALUES IN KILOWATTS)

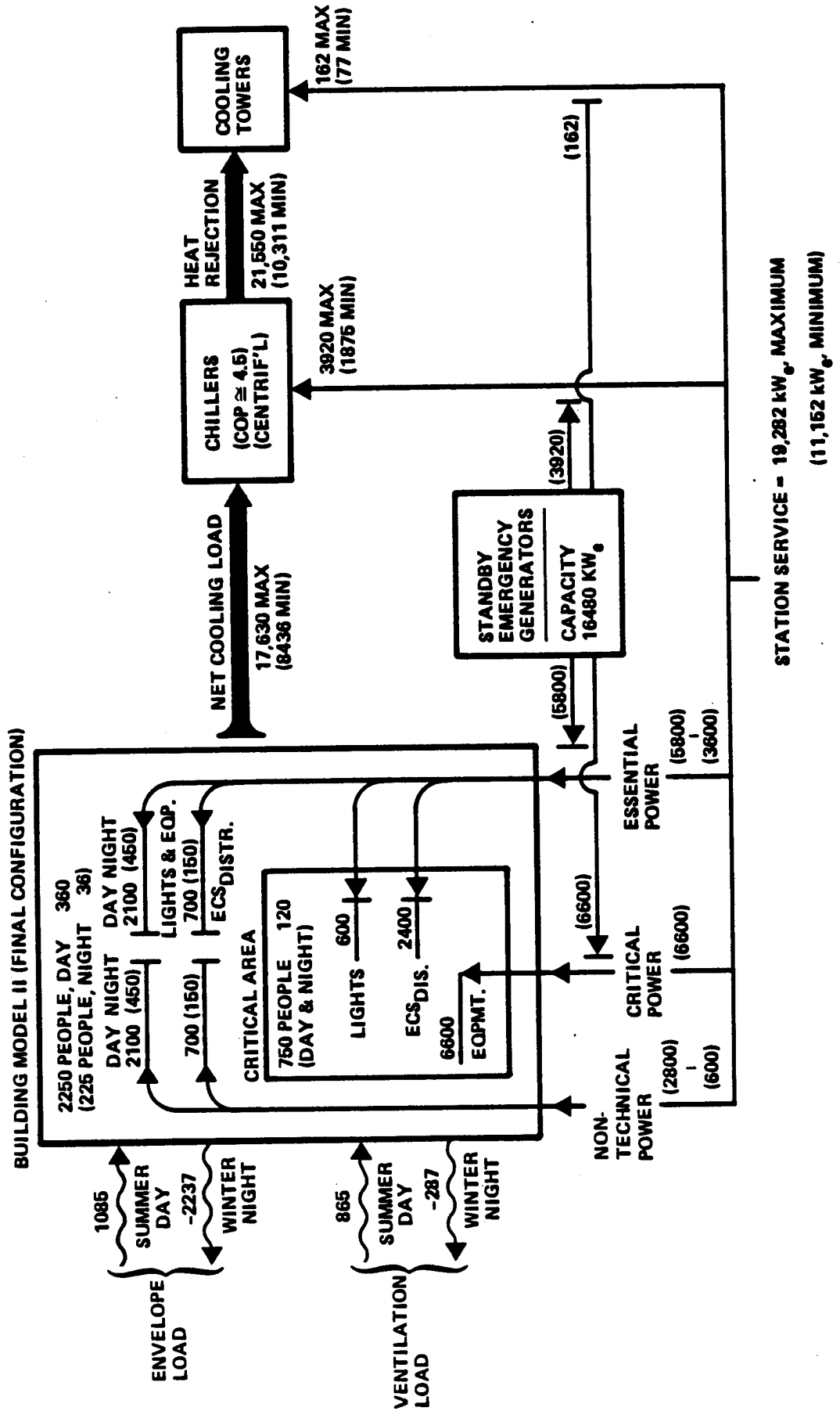

ENERGY FLOWS

ON-SITE PEAK GENERATION (ENERGY VALUES IN KILOWATTS)

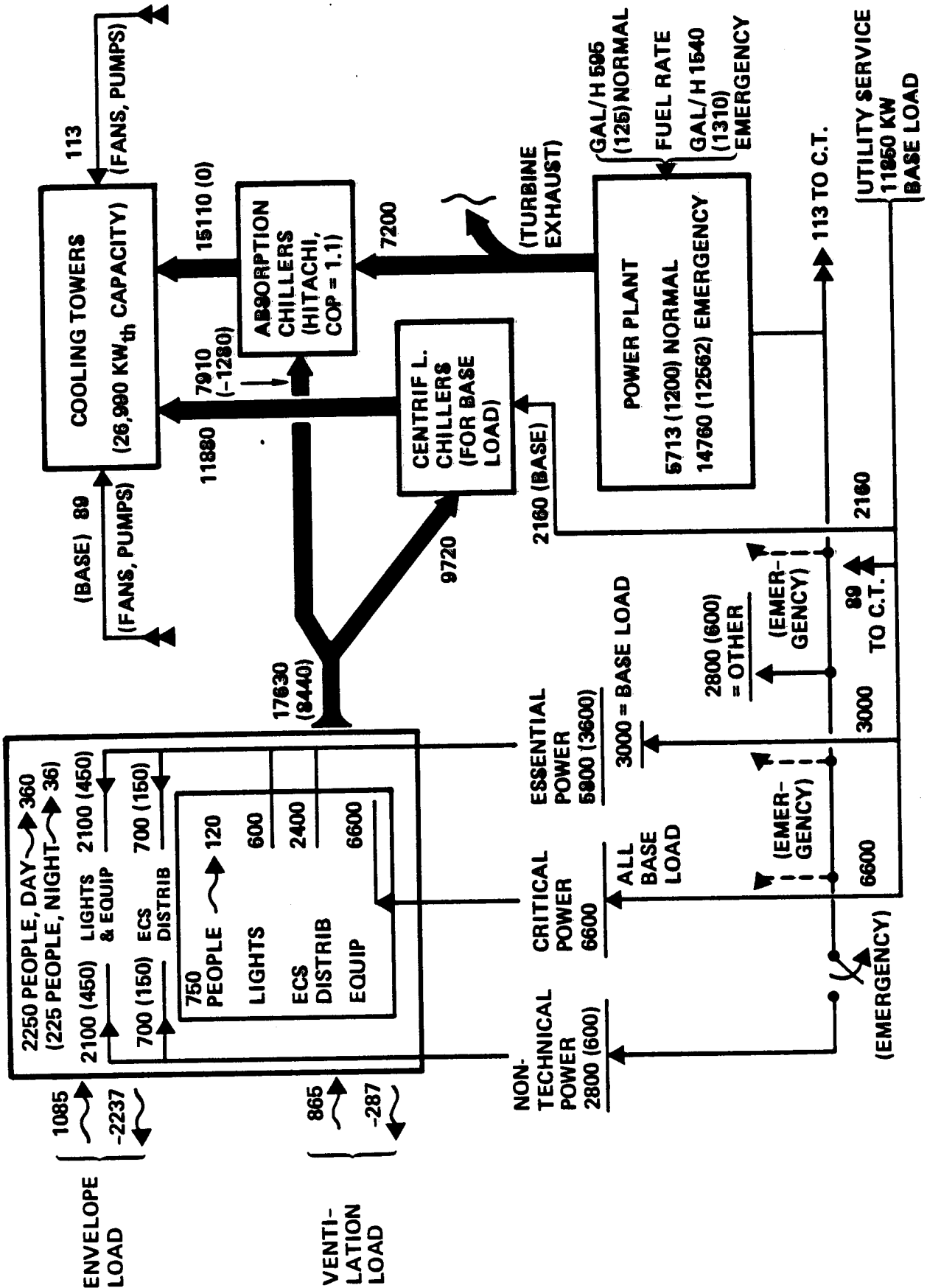

BOTH MODELS I & II

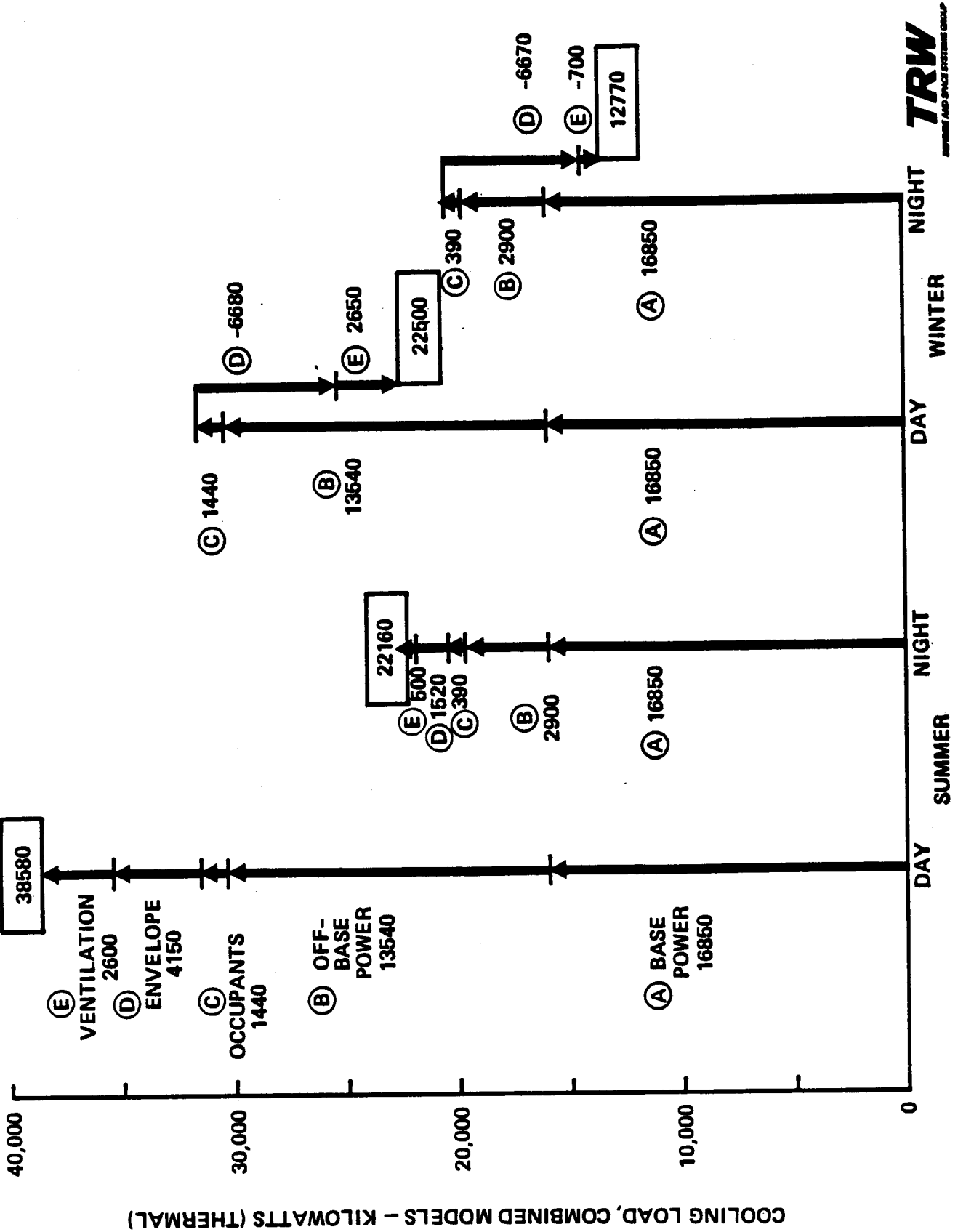

BOTH MODELS I & II ENERGY FLOWS/CO-GENERATION (ALL VALUES IN KILOWATTS)

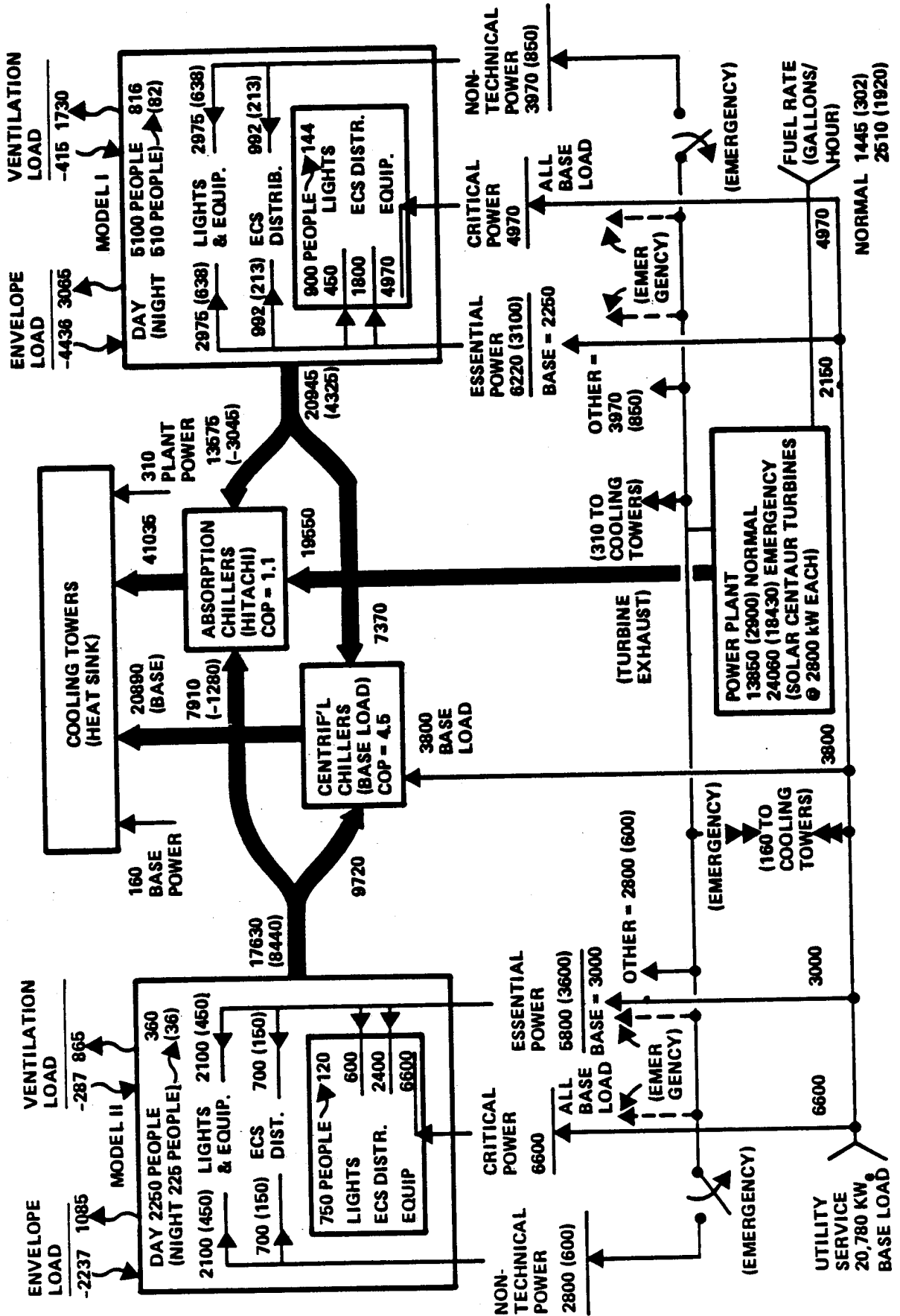

FURTHER EFFORTS

POWER

- DEVELOP 0.9999 AVAILABILITY
 1. REDUNDANT COMPONENTS – DISTRIBUTION AND GENERATORS
- DEVELOP 0.99999 AVAILABILITY
 1. REDUNDANT UPS SYSTEMS
 2. GENERATORS FOR PRIME POWER

ECS

- REDUNDANT COMPONENTS
- COOL STORAGE

FINAL GOAL

- FIRST COST VERSUS AVAILABILITY / POWER & ECS
- LIFE-CYCLE-COST VERSUS AVAILABILITY / POWER & ECS

AVAILABILITY ANALYSIS METHODOLOGY

(Derived from MIL-STD-756A)

A feasibility prediction procedure is used in the conceptual phase of development. This phase covers development of a design from its initial design concept to and including its preliminary paper design.

During this phase the level of information available for environmental, functional, and other requirements is usually restricted primarily to overall aspects of design. Detailed ideas generally are limited to that which may be derived from existing designs similar to that being developed.

The following steps are applicable to all portions of the design:

- a) Define the system
- b) Establish the availability model
- c) Establish the functional complexity
- d) Compute the availability

DEFINE THE SYSTEM:

The system shall be defined in terms of the following:

- a) Purpose, intended use, or mission
- b) Performance - parameters and allowable limits
- c) Functional and physical boundaries
- d) Conditions which constitute item failures

AVAILABILITY MODEL:

Construct an availability block diagram showing the functions, blocks, and relationships that are necessary for successful system operation. Clearly indicate alternate modes of operation. Derive a mathematic equation for the availability of the system and for each functional block in the availability block diagram. Assumptions and simplifications employed in the model are clearly stated.

AVAILABILITY BLOCK DIAGRAM:

The availability block diagram represents a systematic arrangement of functions that must be performed and the sequence in which they must be performed for successful product function. In general, success of the individual components is required for successful operation of the block.

General assumptions that apply to availability block diagrams are as follows:

- a) The lines connecting blocks have no availability values. The lines serve only to give order and direction to the diagram.
- b) Failure of any device denoted by a block in the diagram will cause failure of the entire system, except that alternate modes of operation may be present.
- c) Each device denoted by a block in the diagram is independent, with regard to probability of failure, from all other blocks.
- d) No interface problems occur between man and system, all human elements are completely reliable.

FUNCTIONAL COMPLEXITY:

For each functional block, estimate the functional complexity by type of function and number of parts. Estimate either the failure rate or the probability of success by using data obtained from experience with existing products or from designs having similar requirements. The source and basis of data is stated.

PART FAILURE RATE:

Electronic - Determine the failure rate for each electronic part using MIL-HDBK-217. For electronic parts not covered by MIL-HDBK-216, use existing data and specify the source.

All other parts - Determine the failure rate for each part using existing data or data specified by the procuring activity. Specify the source of data.

SYSTEM AVAILABILITY

Compute the system availability using the mathematical equation derived from the availability block diagram.

The availability of the facilities system is calculated by the computer simulation program, AVAIL.

AVAIL - (Computer simulation program used in the availability prediction.)

AVAIL is a general purpose computer simulation model developed to evaluate the effects of hardware failures and maintenance concept variations upon a system. The model requires inputs of hardware success paths, which are formulated in the availability block diagram, with their respective MTBFs, MTTRs, and switching times.

The model simulates, by Monte Carlo methods, the hardware failures, records the downtime, and checks to see if a spare is available.

If a hot standby spare is available, the model records the time required to switch in the hot standby unit. If there is no hot standby unit, the model checks for shelf spares. If a shelf spare is available, the model records the downtime, and replaces the unit with the shelf spare. If a shelf spare is not available, the model determines the time to repair the failed item and to return it to service.

The program also has a feature which plots availability block diagrams.

The following definitions, from MIL-STD-721, are provided as reference material:

AVAILABILITY - A measure of the degree to which an item is in the operable committable state at the start of the mission, when the mission is called for at an unknown (random) point of time.

DOWNTIME - That element of time during which the item is not in condition to perform its intended function.

FAILURE - The inability of an item to perform within previously specified limits.

FAILURE RATE - The number of failures of an item per unit measure of life (cycles, time, miles, events, etc., as applicable for the item).

INHERENT - Achievable under ideal conditions, generally derived by analysis, and potentially present in the design.

MEAN-TIME-BETWEEN-FAILURES (MTBF) - For a particular interval, the total functioning life of a population of an item divided by the total number of failures within the population during the measurement interval. The definition holds for time, cycles, miles, events, or other measures of life units.

MEAN-TIME-TO-REPAIR (MTTR) - The total corrective maintenance time divided by the total number of corrective maintenance actions during a given period of time.

MISSION - The objective or task, together with the purpose, which clearly indicates the action to be taken.

OPERABLE - The state of being able to perform the intended function.

OPERATIONAL - Of, or pertaining to, the state of actual usage.

PREDICTED - That which is expected at same future date, postulated on analysis of past experience.

REDUNDANCY - The existence of more than one means for accomplishing a given function. Each means of accomplishing that function need not necessarily be identical.

REDUNDANCY, ACTIVE - That redundancy wherein all redundant items are operating simultaneously rather than being switched on when needed.

REDUNDANCY, STANDBY - That redundancy wherein the alternative means of performing the function is inoperative until needed and is switched on upon failure of the primary means of performing the function.

RELIABILITY - The probability that an item will perform its intended function for a specified interval under stated conditions.

Other definitions which apply are:

INHERENT AVAILABILITY - The availability inherent in the design of a system is the probability that the system, when used under stated conditions, without consideration for any scheduled or preventive maintenance action, in an ideal support environment (i.e., available tools, spares, manpower, data, etc.), shall operate satisfactorily at any given point in time. It excludes ready time, preventive maintenance downtime, logistics time, and waiting or administrative downtime. Inherent availability is expressed by the equation:

$$A = \frac{MTBF}{MTBF + MTTR}$$

Where MTBF = means time between failures

MTTR = means time to repair

SINGLE POINT FAILURE

Any piece part, assembly, component, or element of construction, such as printed circuit board layout, the failure of which would result in irreversible degradation of item performance below contractually specified levels, such as failure of an item in operation which could be catastrophic to a mission objective.