

FBIS MODERNIZATION PROGRAM
CONCEPT DEFINITION STUDY
CONCEPT OF OPERATION

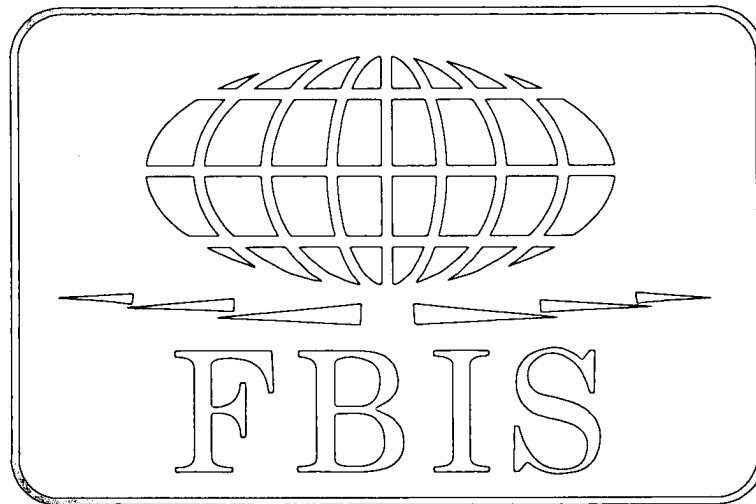

PREPARED FOR

Foreign Broadcast Information Service

Xerox Special Information Systems
Pasadena, California 91109

**FBIS MODERNIZATION PROGRAM
CONCEPT DEFINITION PHASE**

CONCEPT OF OPERATION

XSIS REPORT 6080-1

OCTOBER 30, 1984

Prepared for

FOREIGN BROADCAST INFORMATION SERVICE

UNDER CONTRACT 84X*927800*000

**Xerox Special Information Systems
250 North Halstead Street
Pasadena, California**

XEROX

TABLE OF CONTENTS

1.	SCOPE	1	2.1.18 Node Level Systems Architecture	6
2.	SYSTEM DESCRIPTION	2	2.1.19 Generic Bureau Systems Architecture	6
2.1	System Architecture	2	2.1.20 Headquarters Unclassified Systems Architecture	7
2.1.1	Distributed Processing	2	2.1.21 Headquarters Classified Systems Architecture	7
2.1.2	Workstations	2	2.1.22 JPRS Systems Architecture	9
2.1.3	Servers and Services	3	2.2 Collection Control	9
2.1.4	Local Area Network	4	2.3 Bureau Monitor/Editor Operations	11
2.1.5	Clearinghouse Service	4	2.4 Bureau Data Base Operations	12
2.1.6	Mail Service	4	2.5 Bureau Communications	13
2.1.7	External Mail Gateway Service	4	2.6 Headquarters Unclassified Processing and Composition	13
2.1.8	File Service	4	2.7 Headquarters Classified Processing and Composition	14
2.1.9	Print Service	4	2.8 Headquarters Data Base Operations	15
2.1.10	External Communication Service	4	2.9 Headquarters Communications	15
2.1.11	Asynchronous Communication Protocol	4	3. FUNCTIONAL INTERFACES	17
2.1.12	Interactive Terminal Service	5	3.1 Internal Interfaces	17
2.1.13	Internetwork Routing Service	5		
2.1.14	Remote Batch Service	5		
2.1.15	Server Monitor Service	5		
2.1.16	Database Service	6		
2.1.17	Network Level Systems Architecture	6		

Concept of Operation

XEROX

3.1.1	Bureau Workstation-- Collection Control	17	3.2.4	Phototypesetter	24
3.1.2	Bureau Workstation-- Data Base Operations	19	4.	PROCESS FLOWS	25
3.1.3	Bureau Workstation-- Running Summary	20	4.1	FBIS Overall Operations	25
3.1.4	Headquarters Workstation--Data Base Operations	20	4.2	Field Bureau Operations	25
3.1.5	Headquarters Workstation--Writers Workbench	22	4.3	Field Bureau Administration	28
3.1.6	Receiver--Communica- tions Interface Unit (RTTY)	23	4.4	Automatic Dissemination	29
3.2	External Interfaces	23	4.5	FBIS Wire Service	29
3.2.1	Wire Service	23	4.6	Daily Report	29
3.2.2	Landline--Communica- tions Interface Unit (Press Agency)	23	4.7	Production Group: Area Division	32
3.2.3	Bureau Communica- tions Links (Autodin, etc)	23	4.8	Joint Publications Research Service--Area Section	34
			4.9	Joint Publications Research Service--Publications Section	34
			4.10	Analysis Group	35
			4.11	Liaison and Requirements Branch	38
			4.12	Reference Service	40
			4.13	Monitoring Operations Division	40

XEROX**ILLUSTRATIONS**

2-1	Schematic Diagram of a Typical Distributed System	3	3-2	Document Transfer Form	19
2-2	Principal Components of Global Internet	6	3-3	Monitor/Editor Screens for Live Speech Coverage	21
2-3	Generic Bureau Systems Architecture	7	4-1	FBIS Overall Data Flow Diagram	26
2-4	Headquarters Unclassified Systems Architecture--Services	8	4-2	Field Bureau Data Flow Diagram	27
2-5	Headquarters Unclassified Systems Architecture--Workstations	8	4-3	Wire Service Data Flow Diagram	30
2-6	Headquarters Classified Systems Architecture	10	4-4	Daily Report Data Flow Diagram	31
2-7	JPRS Systems Architecture	10	4-5	Area Division Data Flow Diagram-I	33
2-8	Collection Subsystem	11	4-6	Area Division Data Flow Diagram-II	35
2-9	Datafusion Distributed Database Architecture	16	4-7	JPRS Area Section Data Flow Diagram	36
3-1	Receiver Control	18	4-8	JPRS Publications Section Data Flow Diagram	37
			4-9	Analysis Group Data Flow Diagram	39

XEROX

SECTION 1

SCOPE

This document describes the proposed modernized FBIS system at the concept definition level. Section 2 describes how the system operates by identifying system functions, indicating the way in which functions are allocated to system hardware and software segments, and connecting segments to form a system block diagram. The block diagrams illustrate the relationships between the system segments and provide the basis for a discussion of the

relationships between the processing, communications and DBMS portions of the system. Section 3 describes external and major internal interfaces of the system. These interfaces include both user interfaces and interfaces between system segments. Section 4 describes system activities through the use of a series of data flow diagrams which trace the flow of information from the collection source to the published and disseminated products.

XEROX

SECTION 2

SYSTEM DESCRIPTION

2.1 SYSTEM ARCHITECTURE

This section introduces the system architecture and the general idea of operation in a distributed system environment. Distributed processing concepts are introduced, followed by a discussion of the various elements of the system architecture. Finally the architectures developed for the Field Bureaus and the several segments of the Headquarters operation are presented.

2.1.1 Distributed Processing

System architectures which distribute computer resources over a shared communication medium are known generically as *distributed processing*. This modern architecture philosophy is rapidly superseding the traditional centralized processing architectures which are based on mainframes and relatively simple terminals at user locations. The principal advantages of distributed processing are in the areas of:

- Performance
- Reliability
- Cost

By distributing the processing power to the point of use, the system architecture achieves more than high quality user interfaces, it particularly enables system extension in small economic units. Since each new unit also brings its own increment of processing power with it, new users fit gracefully into the system with minor impact on existing performance. Furthermore, reliability is increased when functions are distributed across multiple computer-based devices and not concentrated in a single mainframe.

Xerox distributed processing systems are organized into the Xerox Network Systems (XNS) architecture. This architecture defines the set of principles, formats, and conventions that govern the exchange of information among the "citizens" of this architecture. A network citizen can communicate easily on a local network or with remote networks across town or across the world. XNS architecture integrates information handling for network citizens and enables local area networks to join together to form wide area networks.

Network citizenship is not restricted to Xerox products. Xerox has provided hardware and software to make the IBM PC and its compatibles into network citizens. Compatibility software enables non-network citizens to access the shared resources offered by Xerox network services. Both personal computers and standard terminals can dial into the network to achieve a temporary connection with one of the compatibility services. These services also enable network citizens to access the products of other vendors and other network architectures, such as IBM's System Network Architecture.

Figure 2.1 shows a typical distributed system. It illustrates how network citizens are interconnected to provide a desired functionality. Network citizens fall into two principal categories: *workstations* and *servers*. The following sections describe these citizens in more detail.

2.1.2 Workstations

A workstation consists of a computer devoted to one user at a time, a typewriter-like keyboard, a display screen or other output device, some

XEROX

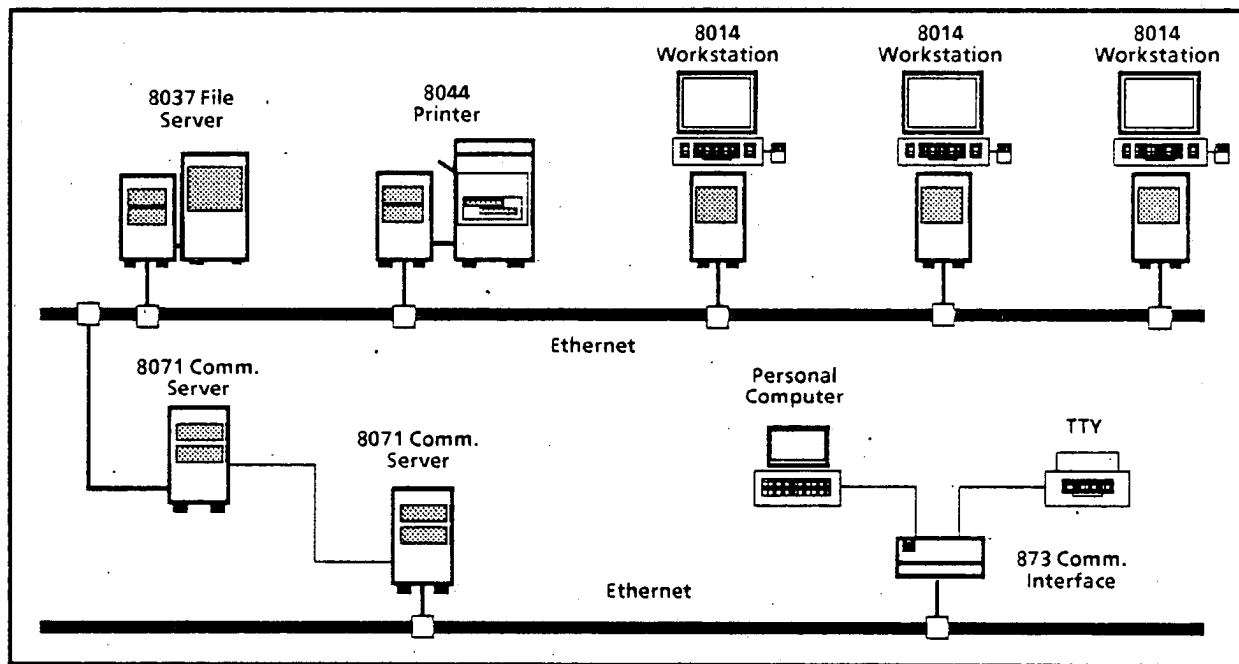

Figure 2-1 Schematic Diagram of a Typical Distributed System

storage for programs and documents, and a connection to a local network.

One of the family of network-citizen workstations created by Xerox is the Dandelion processor and display running the Star software. This workstation, often referred to as a Star workstation, is an especially effective multi-function workstation with a multiple window capability which enables the user to communicate with many services at one time. Its efficient user interface makes network resources such as mail, print and file appear as desktop resources on the display.

2.1.3 Servers and Services

A server is a system element that supplies one or more shared network resources to Xerox network citizens. Each Xerox network installation includes at least one server dedicated to the support of one or more of the Xerox services. *Server* refers to the hardware; *service* refers to the software providing a particular shared resource. Many workstations can use and

share the services running on a single server. Servers can perform many tasks at one time for many workstation users.

A network service is the software that makes a shared resource available to network citizens. This resource could be a peripheral, such as a printer or large database system, or it could be an element of a distributed support mechanism, such as a directory, mail, or compatibility service. Services usually do not initiate action but are always available to answer requests over the network from clients who wish to use their capabilities. A client may be a user at a workstation (for example, sending a document to be printed), or another service (for example, a File Service checking with the Clearinghouse Service to determine a user's access rights to a file drawer). The requesting client can be on the same or a different network so long as the request follows the protocols appropriate for the service.

XEROX

2.1.4 Local Area Network

The Xerox local area network (LAN) is called Ethernet and is based on a coaxial cable. This is an industry standard network (IEEE 802.3 standard for CSMA/CD protocols) that carries packets of information to equipment at 10 million bits per second. This high speed network, provides a flexible, low cost connection between individual workstations and shared servers within an establishment or through multiple interconnected Ethernets (an internetwork). An internetwork (internet) is the composite of interconnected networks in which all elements attached to any of the networks can communicate with any other element attached to the network.

2.1.5 Clearinghouse Service

The Clearinghouse Service (CHS) helps provide the foundation for the other network services. It is not needed on all servers, but all networks must have access to at least one Clearinghouse. It forms a network community, comprised of people, services, servers and resources that are managed by the services. All these network entities must be named and registered in the Clearinghouse, providing a system-wide directory of the network. Through the Clearinghouse, all other services find the information needed to answer requests, such as where a user's mailbox is located for mail distribution, freeing the user from memorizing complex pathnames. The Clearinghouse also authenticates users when they access network resources, providing network security.

2.1.6 Mail Service

The Mail Service (MS) provides an electronic post office which offers almost instant communication between network users. Messages consisting of plain text notes or complex documents containing graphics can be sent to any registered user. The MS requires a File Service for backing up its database.

2.1.7 External Mail Gateway Service

The External Mail Gateway Service enables mail exchange between internets while preventing other forms of interaction (for example, file access) between the internets involved. Modified External Mail Gateways will be used for connection to Autodin and for one-way computer-to-computer connection from the unclassified FBIS HQ system to the classified HQ system.

2.1.8 File Service

The File Service (FS) provides large volume storage of documents and folders for multiple users on the network. Users can share information efficiently through this storage facility. File services will provide storage for in-process documents in the FBIS System.

2.1.9 Print Service

The Print Service (PS) provides a network resource for obtaining printed output of documents for multiple users. Electronic (laser) and facsimile printers associated with PS can produce documents with graphic illustrations, equations, multiple fonts, and text with exacting detail. A modification to PS will enable output to APS-5 phototypesetters.

2.1.10 External Communication Service

The External Communication Service (ECS) supports information exchange between Xerox network devices and non-Xerox devices. The ECS enables networked workstations to access mainframe computers through terminal emulation. It is capable of interpreting foreign (non-Xerox) protocols so that information can flow between the network and the foreign device.

2.1.11 Asynchronous Communication Protocol

Asynchronous Communication Protocol works with the External Communication Service to support emulation sessions in which the

XEROX

workstation emulates a VT100 or standard TTY-type terminal. With the emulation protocol on the server and emulation software on the workstation, workstation users can interact with remote hosts. VT100 emulation will be used for much of the interaction with Digital Equipment Corporation VAX servers running database functions.

2.1.12 Interactive Terminal Service

The Interactive Terminal Service (ITS) enables users of remote personal computers and teletype terminals to access the Network Mail and File Services. The ITS requires External Communication Service with Asynchronous Communication Protocol activated in order to access these services.

2.1.13 Internetwork Routing Service

The Internetwork Routing Service (IRS) interconnects Ethernets to form a larger single network called an internetwork. This larger network unites users, workstations, services, and servers, allowing the all the resources on the networks to be shared using the same conventions regardless of their location.

2.1.14 Remote Batch Service

Remote Batch Service (RBS) provides document interchange and file transfer facilities with devices that require the IBM Binary Synchronous (BSC) data transmission protocol. This protocol is used by the IBM 2770, 2780, and 3780 remote batch terminals, and is often emulated by other major data processing and word processing devices. RBS uses the File Service for storage of documents received from remote devices. Modifications to the RBS will be used to implement the FBIS "News Service" to capture press agency copy.

2.1.15 Server Monitor Service

The Server Monitor Service (SMS) keeps track of one or more servers on the Ethernet or internet. At established intervals, it connects to the

designated server and generates a log about that server's performance. SMS requires the use of a File Service for backup of this log.

2.1.16 Database Service

The Database Service runs on Digital Equipment Corporation (DEC) VAX machines and supports several different database management systems (DBMS) depending on whether it is deployed at Bureau or HQ locations. At HQ locations the Database Service also requires Datafusion Corporation hardware devices. The DBMS software used is:

	Headquarters	Bureaus
DEC Rdb	<input checked="" type="checkbox"/>	<input checked="" type="checkbox"/>
Battelle BASIS	<input type="checkbox"/>	<input checked="" type="checkbox"/>
Datafusion	<input checked="" type="checkbox"/>	<input type="checkbox"/>

2.1.17 Network Level Systems Architecture

The geographical internet architecture enables information interchange among multiple geographically separated networks such as the FBIS Bureaus, Headquarters, Lateral Consumers, Wire Service Customers and Agency computers. Figure 2-2 shows a schematic diagram of the geographical distribution of the principal components of FBIS internet.

The Headquarters internet consists of three principal networks:

1. Headquarters unclassified network which includes, Operations Group, Analysis Group, and part of Production Group.
2. Headquarters classified network for the Analysis Group.
3. JPRS network.

A one-way-only Mail Gateway connects the *unclassified* HQ network to the *classified* HQ network via a fiber-optic link. An Internetwork Routing Service connects the *unclassified* HQ network to the JPRS network.

XEROX

A classified interface connects the HQ *classified* network with Agency computers.

A Communication Interface Unit (873) connects to the existing Wire Service lines for traffic to Wire Service Customers.

A modified Mail Gateway connects the HQ internet with the Autodin switches at Fort Detrick and Andrews AFB.

Bureaus connect via Autodin I & IV, DoS COMSAT, DTS, DCS, Telex, and leased lines to the HQ internet.

2.1.18 Node Level Systems Architecture

The node level systems architecture describes distribution among multiple computers (such as workstations and servers) colocated in a single processing facility, communicating through their

own I/O channels and local area network (LAN). The systems architecture for the following networks is described:

- Generic Bureau System
- Headquarters Unclassified System
- Headquarters Classified System
- JPRS System.

2.1.19 Generic Bureau Systems Architecture

The Bureau systems architecture uses distributed processing and resource uniformity as a fundamental philosophy to enable easy scaling of each Bureau's individual network installation to satisfy its specific size and function requirements. Figure 2-3 diagrams a generic bureau network: The architecture uses standard-product 8000NS workstations and servers from

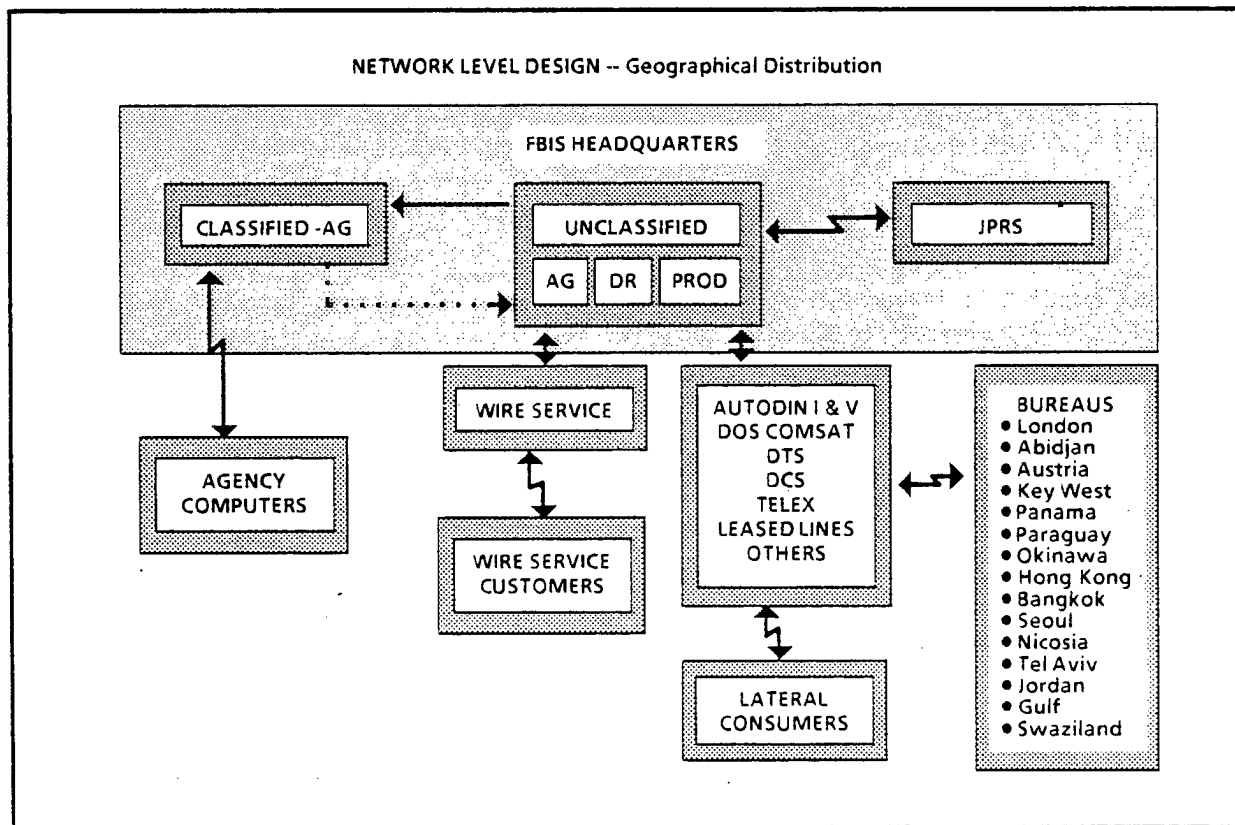

Figure 2-2 Principal Components of Global Internet

System Description

XEROX

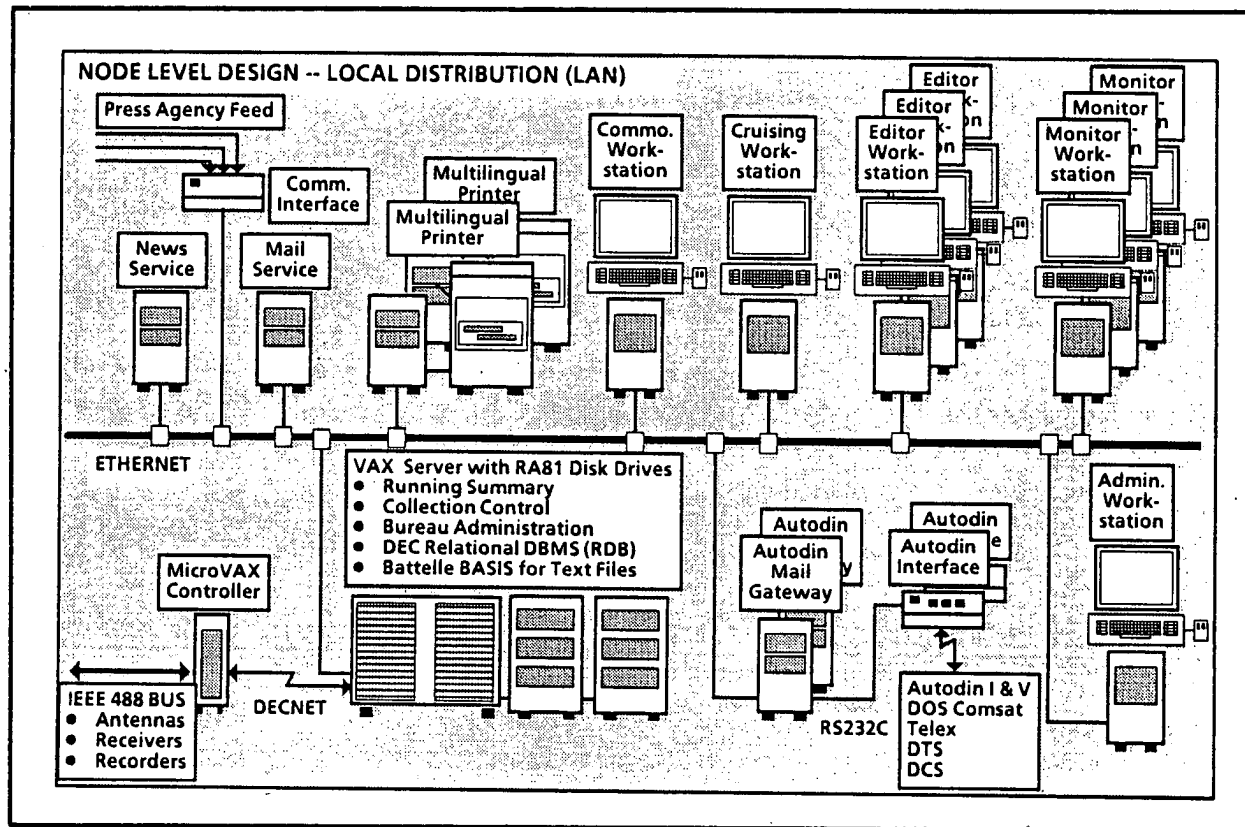

Figure 2-3 Generic Bureau Systems Architecture

Xerox plus standard-product VAX servers from Digital Equipment Corporation (DEC). Database software from DEC (VAX Rdb) and Battelle (BASIS) provides for access to permanent data. Special Bureau needs require some customization of the standard software but no hardware development is needed.

2.1.20 Headquarters Unclassified Systems Architecture

The Headquarters Unclassified System architecture uses the same distributed architecture and equipment as is used for the Bureaus. In addition, a distributed high-performance database management system from Datafusion Corporation enables rapid access to all permanent data and enables economic extension of the database. Figures 2-4 and 2-5 show the services and workstation portions of the architecture.

The HQ Unclassified System connects via a standard Internetwork Routing Service (IRS) to the JPRS system and via a one-way modified Mail Gateway service to the HQ Classified System.

2.1.21 Headquarters Classified Systems Architecture

Because security needs require *one-way-only* computer-to-computer communications between unclassified and classified networks, it is necessary to replicate the unclassified FBIS database in a classified environment. This requires a separate classified installation that performs all functions offered by the unclassified system, except for communication to unclassified systems.

All incoming unclassified material that ends up in the database and all incoming messages destined for mailboxes on the HQ Classified System are

XEROX

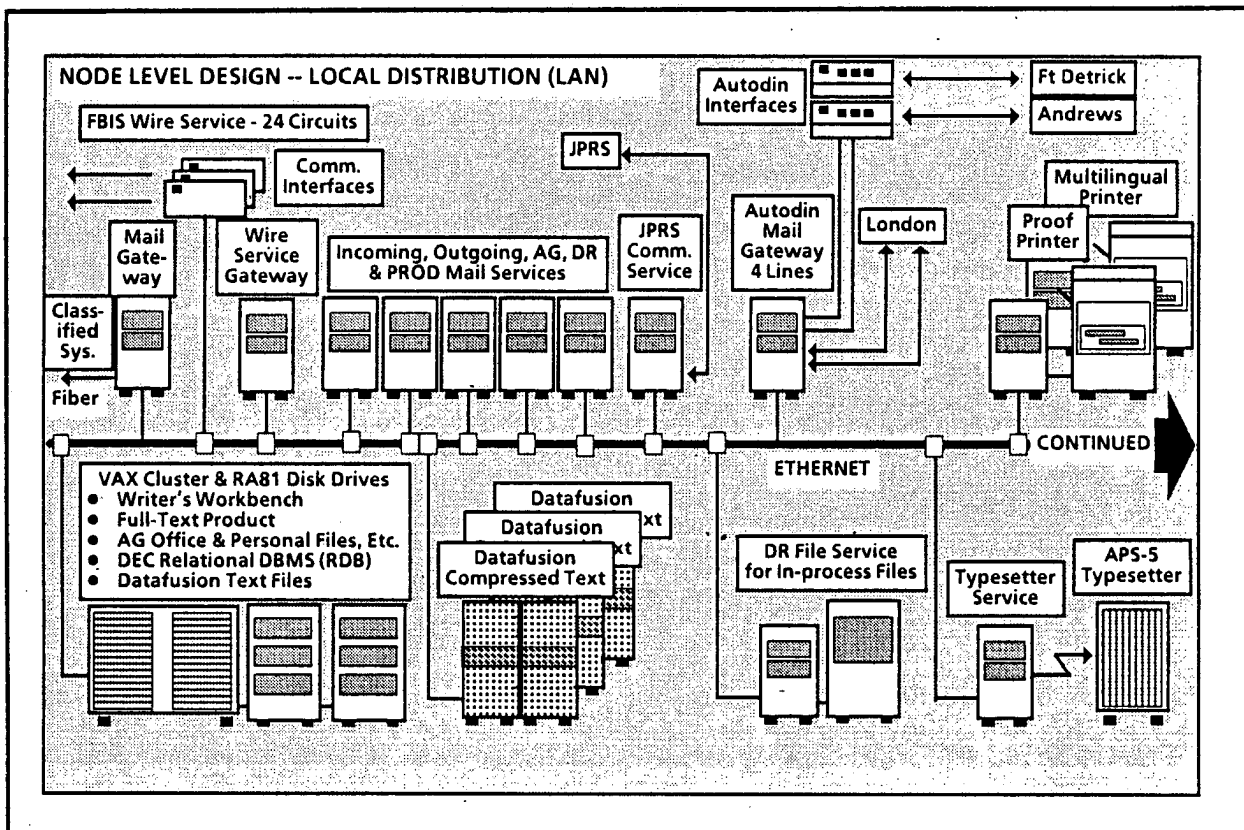

Figure 2.4 Headquarters Unclassified Systems Architecture -- Services

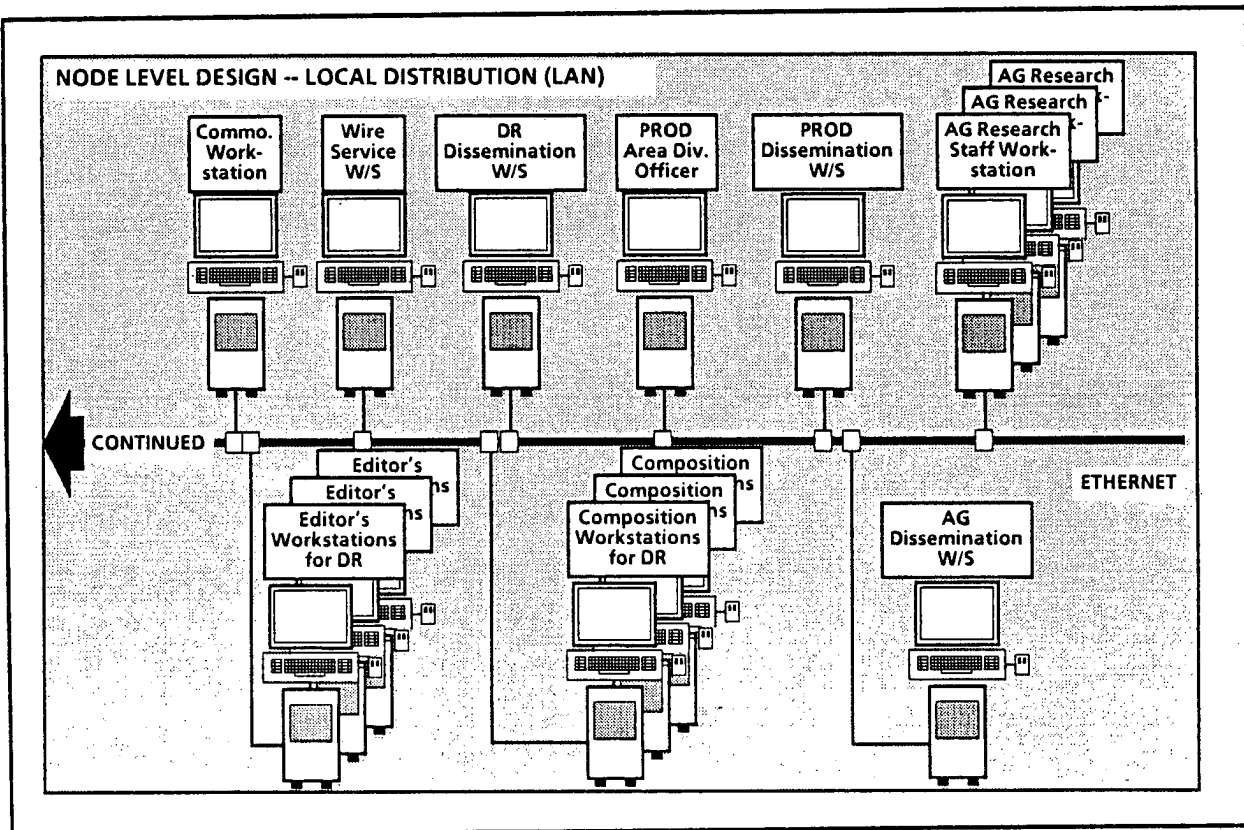

Figure 2-5 Headquarters Unclassified Systems Architecture -- Workstations

XEROX

transmitted to the Classified System via a modified Mail Gateway and one-way-only fiber-optic link. Sanitized documents can be written to flexible disk media for transfer in the other direction to the unclassified network.

A classified communications interface is used for communications with Agency computers. Figure 2.6 shows the Headquarters Classified Systems Architecture.

2.1.22 JPRS Systems Architecture

The JPRS network also uses the distributed processing architecture employed for the other Headquarters networks. JPRS may be located remotely and tied into the HQ Unclassified network as shown in Figure 2-7, or colocated. Independent contractors may communicate with JPRS via the Interactive Terminal Service (ITS) or via flexible diskettes. A networked IBM PC has been supplied for interfacing with the diskettes.

2.2 COLLECTION CONTROL

The collection control subsystem consists of the following components: antennas; antenna multicouplers; computer-controlled coaxial matrix antenna switches; TV tuners and HF receivers; computer-controlled matrix receiver/tuner output switches; computer-controlled audio and FAX-type recorders; and a minicomputer.

Control of the collection subsystem is accomplished by a Boardman file-driven computer that selects the proper antennas, sets the receiver parameters, switches the receiver outputs to the proper monitor and/or recorder, and turns on the desired recorders according to the schedule using an IEEE-488 bus.

The block diagram shown in Figure 2-8 illustrates the configuration of the equipment in the collection subsystem. Note that this is a generalized block diagram as the specific number of antennas, receivers, and recorders will vary according to the requirements at a

particular bureau. The system has been specifically designed with modularity in mind so that satisfying the differing configuration requirements for various sized bureaus is not a problem. Referring to the block diagram, some of the pertinent features of the architecture can be observed:

- all TV and HF antennas can be computer-switched to any acceptable receiver or tuner
- Cruiser antennas bypass the computer-switches to allow manual selection of any antenna since this operation is not sufficiently scheduled to permit computer control
- TV tuners are provided to convert all incoming channels to a common one so that all TV sets can then be set to the same channel and the channel switching accomplished by computer
- the TV sets in the Monitor's positions are always ON and just prior to a scheduled event the Monitor is sent an Alert message and the proper channel is computer-switched to the set
- complete control of the HF receivers is provided including frequency, bandwidth, gain, etc.,
- note that Monitor control is also provided as discussed in Sec. 3.1.1
- computer-controlled switches are provided at the output of all receivers and tuners capable of selecting any Monitor position or recorder.

System operation begins with the Boardman operator using the Terminal of the MicroVax computer to retrieve the proper Boardman file from the bureau DBMS computer via the DECNET connection. The operator modifies the schedule, if required, and assigns specific equipment to the schedule items. Software assistance is provided

Concept of Operation

XEROX

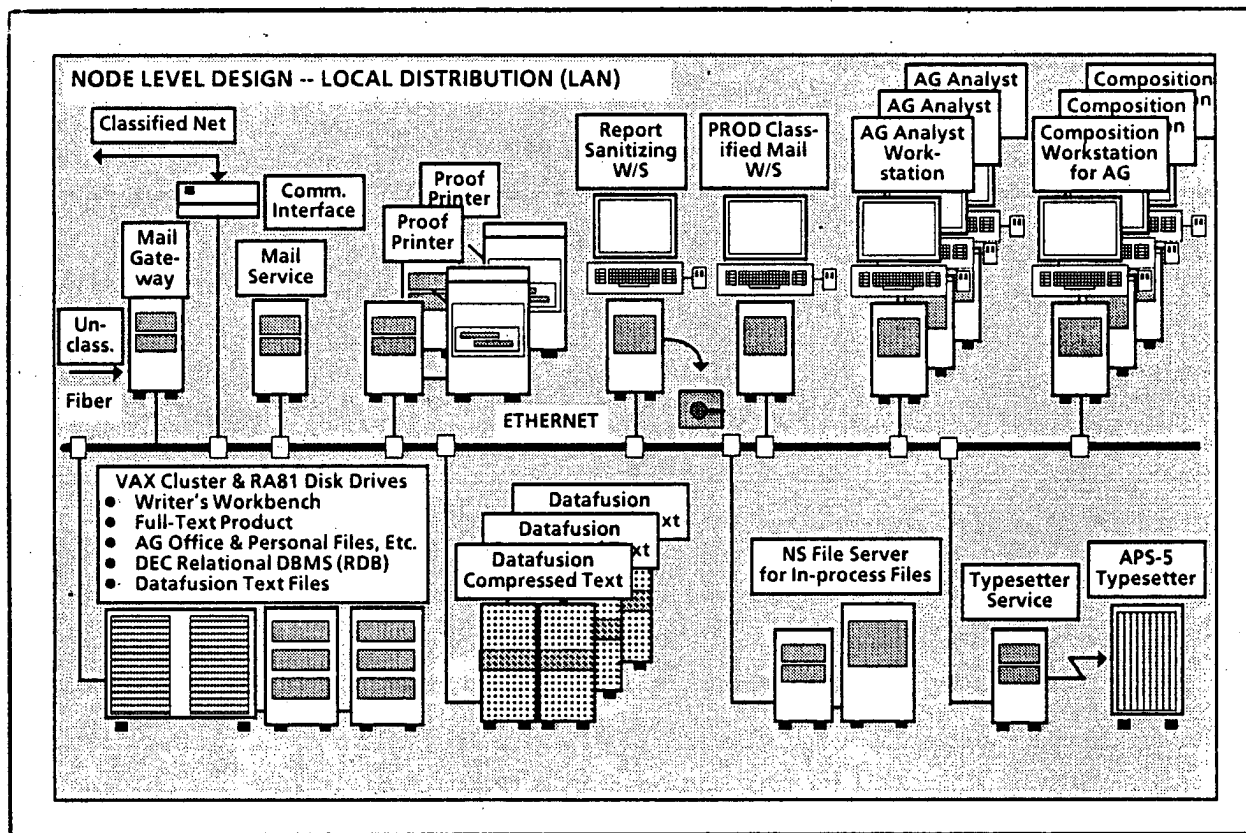

Figure 2-6 Headquarters Classified Systems Architecture

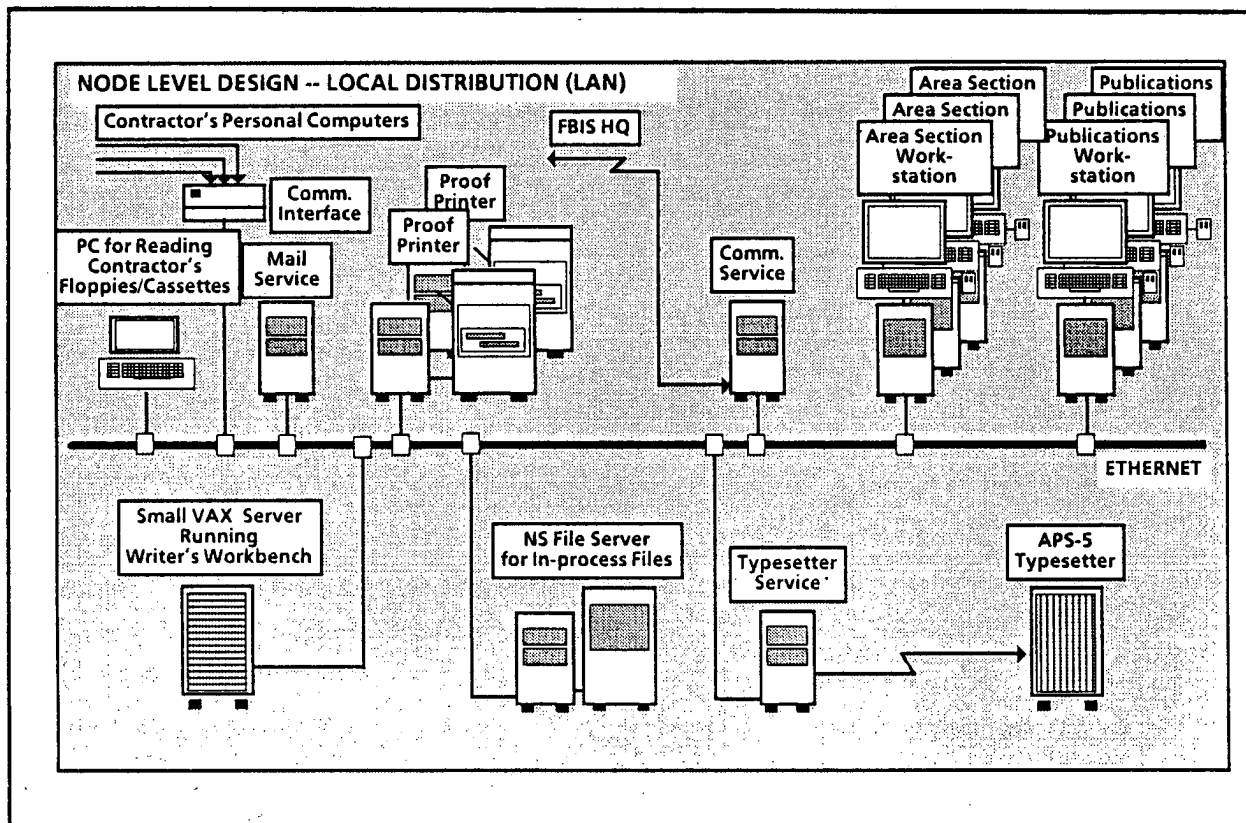

Figure 2-7 JPRS Systems Architecture

System Description

XEROX

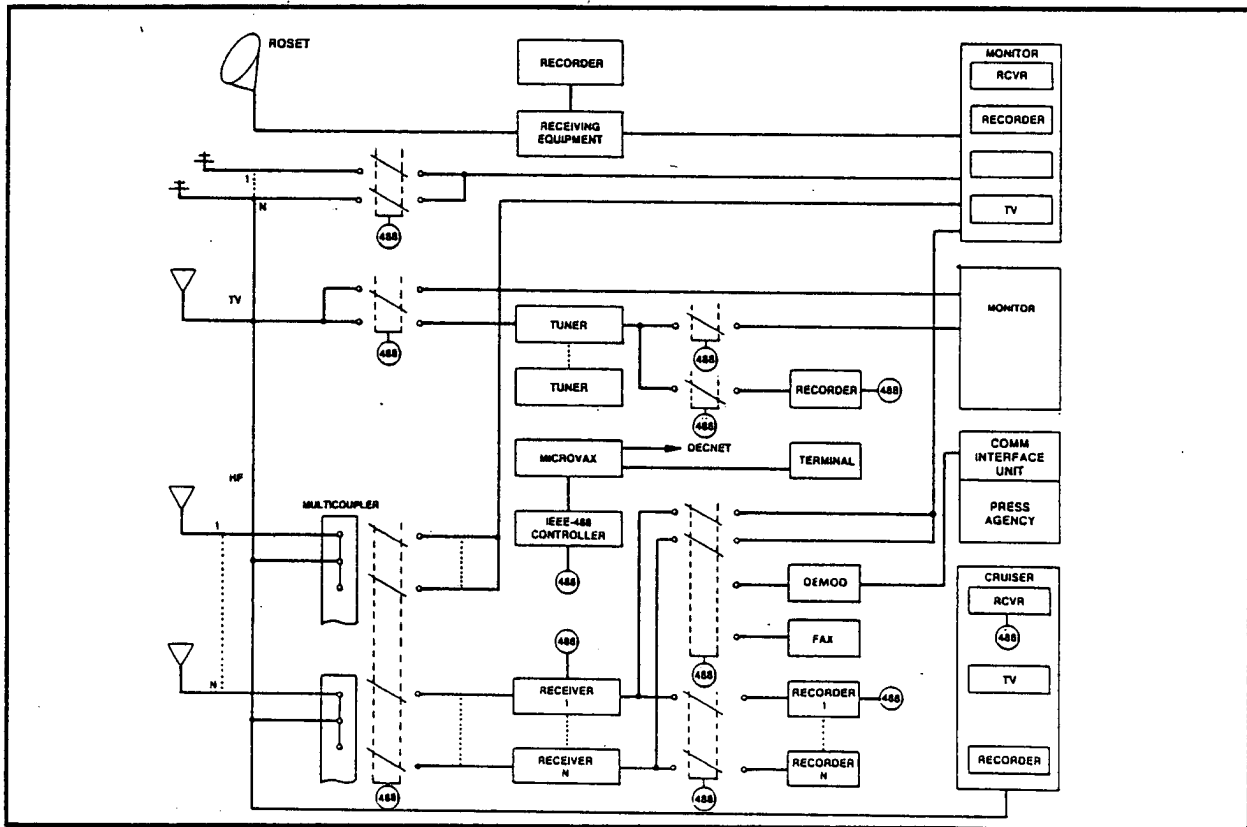

Figure 2-8 Collection Subsystem

to the operator in terms of equipment compatibility and usage inventory. In addition, software is provided to allow the operator at any time to examine and modify the schedule or equipment assignment and to observe and diagnosis system operations.

2.3 BUREAU MONITOR/EDITOR OPERATIONS

The Field Bureau Monitors and Editors perform their duties at workstations connected to the distributed network. These workstations provide each user with his own individual processing power, personal local storage for working copies of documents as well as the operational software, keyboard with functional keys and pointing device, and bit-mapped CRT display. Each display screen can be divided up into a number of separate areas, known as 'windows', which permit different activities, of the same or different types, to be performed without

affecting the status of others. In particular, each workstation provides text/document processing, message traffic handling, Press Agency display and processing (if in English), filing/DBMS storage, and terminal emulation capabilities for accessing the database host.

The message traffic handling software provides a Table of Contents, access to individual messages, and the ability to compose and send messages as well as to answer and/or forward those in the TOC. Alerts are provided on the workstation when there is new mail, urgent message traffic, or urgent Press Agency copy. English Press Agency copy can be copied directly into a message composition window for immediate processing and dissemination. The text/document processing software provides an Edit Trace capability which allows the user, at his discretion, to view the changes made since the

XEROX

previous version of the document was created. Glossaries and other Reference Aids can be displayed on the workstation screen, and extracts of their contents copied into documents and messages in process.

Shared functionality is provided by means of Services which are accessed over the distributed network. Services provided at the Field Bureau include Mail Service, 'News' Service, Autodin Mail Gateway, and Print Service in addition to those services provided by the database host. The Mail Service provides a set of mailboxes, one for each user, from which the message handling software on the user's workstation retrieves the messages for that user. The Mail Service also provides some 'well-known' mailboxes which contain shared traffic (such as drop copy or operational traffic), and are processed differently from the individual mailboxes (since messages are not removed from them by the act of being read).

The 'News' Service provides separate directories for each Press Agency traffic stream being captured, which operate very much like the 'well-known' mailboxes. Well-known mailboxes and News Service directories provide Tables of Contents to the user who accesses them, and allow the user to peruse individual items of his choice. At regular intervals, the traffic in the well-known mailboxes and News Service directories is printed to be available for read-in, and moved to the database, where it is retained for the required 30-day or 60-day period. This system provides the capability to capture character-oriented vernacular Press Agency traffic, which can be printed on the multi-lingual Print Service, and displayed (but not edited) on the workstation screen. The Print Service uses a laser printer to produce output on plain paper.

The Autodin Mail Gateway provides the network interface to the Bureau communications system, for both incoming and outgoing message traffic. The only network user to access the Autodin Mail Gateway directly is the Communications

Operator. That part of the system is covered in section 2.5 of this Concept of Operation. For all other users (and for the Communications Operator, when he is sending messages as opposed to controlling the queues), the Autodin Mail Gateway is accessed using the Mail Service, which performs its interactions with the Gateway in a manner which is totally transparent to the user.

2.4 BUREAU DATA BASE OPERATIONS

The bureau data base is divided into two types of data, structured data and unstructured textual data. There are two corresponding data base management systems.

VAX Rdb/VMS (from Digital Equipment Corporation), a relational data base management system, is used to maintain the structured data. Structured data are such things as inventory, personnel and cruising and they generally involve the daily operations of the field bureaus.

BASIS (from Battelle Corporation), a data base management system that is optimized to process text, is used to maintain the loosely structured text. Loosely structured text are such things as incoming and outgoing messages, program summaries and English language press agency. They are kept for 30 or 60 days and then are purged.

Interfaces to the data bases are handled through several system components

The data base icon on the workstation is used to transfer documents to BASIS.

Query, report writing and forms control packages that come with VAX Rdb/VMS and BASIS are used in the VT100 terminal emulation window to control the data in the data bases.

The terminal emulation and file transfer with the VAX computer are accomplished with EVMS

XEROX

(from Xerox). EVMS is the hardware and software interface between VAX/VMS and Xerox products running the XNS (Xerox Network System) protocols.

2.5 Bureau Communications

Facility for bureau communications is provided by the following system components shown in Figure 2-3:

- Commo Workstation,
- Autodin Mail Gateway, and
- Autodin Interface.

All outgoing traffic is routed to the Commo Workstation from the Slot Editor. The Commo Operator checks the format, adds additional header information as necessary and forwards the traffic to the Autodin Mail Gateway.

The Autodin Mail Gateway is a stand-alone server on the local network. It receives all outgoing traffic from the Commo Workstation and provides the queueing, precedence handling, error checking, logging and filing functions. After completion of processing, outgoing traffic is released to the Autodin Interface for transmission. In addition, the Gateway receives all incoming traffic from the Autodin Interface. Again, the functions of queueing, precedence handling, error checking, logging and filing are provided for the incoming traffic. The incoming traffic is then routed to the appropriate mailbox and alerts issued if indicated by precedence. Note that Commo Operator intervention is not required for incoming traffic.

The Autodin Interface serves as the bridge between the generic form of the traffic within the local network and the specific protocols of the various communications links. Autodin Modes I and V, DOS Comsat, DTS, DCS and Telex protocols are provided.

2.6 HEADQUARTERS UNCLASSIFIED PROCESSING AND COMPOSITION

The users of the FBIS Headquarters Unclassified system perform their duties at workstations connected to the distributed network. These workstations have the same hardware configuration and user interface as the workstations at the Bureaus. Some of the workstations have document composition capabilities. Others provide multi-lingual text entry and editing and document processing.

The message traffic handling software provides a Table of Contents, access to individual messages, and the ability to compose and send messages as well as to answer and/or forward those in the TOC. Alerts are provided on the workstation when there is new mail, or urgent message traffic. The text/document processing software provides an Edit Trace capability which allows the user, at his discretion, to view the changes made since the previous version of the document was created. Glossaries and other Reference Aids can be displayed on the workstation screen, and extracts of their contents copied into documents and messages in process.

Shared functionality is provided by means of Services which are accessed over the distributed network. Services provided on the Headquarters Unclassified system include Mail Service, Autodin Mail Gateway, FBIS Wire Service Gateway, Print Service, File Service, 'Typesetter' Print Service, and Writer's Workbench, in addition to those services provided by the database host. The Mail Service provides a set of mailboxes, one for each user, from which the message handling software on the user's workstation retrieves the messages for that user. The Mail Service also provides some 'well-known' mailboxes which contain shared traffic (such as publishable messages or operational traffic), and are processed differently from the individual mailboxes (since messages are not removed from them by the act of being read). Well-known mailboxes provide Tables of

XEROX

Contents to the user who accesses them, and allow the user to peruse individual items of his choice. At regular intervals, the traffic in the well-known mailboxes is printed to be available for read-in, and moved to the database. The Print Service uses a laser printer to produce output on plain paper. Some of the Print Services have multi-lingual capability.

The Autodin Mail Gateway provides the network interface to the Bureau communications system, for both incoming and outgoing message traffic. The only network user to access the Autodin Mail Gateway directly is the Communications Operator. That part of the system is covered in section 2.9 of this Concept of Operation. For all other users (and for the Communications Operator, when he is sending messages as opposed to controlling the queues), the Autodin Mail Gateway is accessed using the Mail Service, which performs its interactions with the Gateway in a manner which is totally transparent to the user.

The FBIS Wire Service Gateway provides the network interface to the FBIS Wire Service, for outgoing wire traffic. The FBIS Wire Service Gateway is accessed using the Mail Service, which performs its interactions with the Gateway in a manner which is totally transparent to the user. The only time the Wire Service Gateway is accessed directly is for controlling the queue. That part of the system is covered in section 2.9 of this Concept of Operation.

The File Service is provided for use by the workstation composition software, in its document management activities. Files stored on the File Service constitute work in-process only. During the editing and review process, the syntax, etc. of document content may be checked by sending the document to the Writer's Workbench Service, which processes the text and returns the document and the analysis to the workstation. Completed composed documents are sent to the phototypesetter by means of the

'Typesetter' Print Service, which is a specially modified version of the Print Service, connected to a local or remote phototypesetter, rather than a laser printer.

A one-way Mail Gateway allows messages and documents to be sent from the Unclassified system to the Classified system.

2.7 HEADQUARTERS CLASSIFIED PROCESSING AND COMPOSITION

The users of the FBIS Headquarters Classified system perform their duties at Tempest-proofed workstations connected to the Classified network. Each workstation provides text/document processing, message traffic handling, filing/DBMS storage, and terminal emulation capabilities for accessing the database host. Some of the workstations have document composition capabilities. A specific workstation is designated for the creation of floppy disks for the transfer of sanitized (i.e. Unclassified) versions of Classified reports to the Unclassified system.

Message traffic is handled in the same way as on the unclassified system, except that the classified user has access to both classified and unclassified messages.

Shared functionality is provided by means of Services which are accessed over the distributed network. Services provided on the Headquarters Classified system include Mail Service, Print Service, File Service, 'Typesetter' Print Service, and Writer's Workbench, in addition to those services provided by the database host. A one-way Mail Gateway allows messages and documents to be received by the Classified system from the Unclassified system. The Mail Service provides a set of mailboxes, one for each user, from which the message handling software on the user's workstation retrieves the messages for that user. The Print Service uses a laser printer to produce output on plain paper. Document check using Writer's Workbench, document

System Description

XEROX

composition and interface to the phototype-setter are the same as described for the unclassified system.

2.8 HEADQUARTERS DATA BASE OPERATIONS

The headquarters data base is divided into two types of data, structured data and loosely structured textual data. There are two corresponding data base management systems. Two significant differences between the headquarters and the field bureaus are the size of the loosely structured data base and the number of users of the data bases.

VAX Rdb/VMS (from Digital Equipment Corporation), a relational data base management system, is used to maintain the structured data. Structured data are such things as Contract Status Orders (CSO), inventory, personnel and cruising and they generally involve the daily operations of the headquarters and the field bureaus.

The Text Search Processor (from Datafusion Corporation) is used to maintain the loosely structured text. Loosely structured text includes the daily reports, AG reports and JPRS reports. The TSP (Text Search Processor) is optimized to do text search operations.

A number of TSPs, depending on the size of the data base, are attached to the Ethernet. Each TSP is responsible for searching its own part of the data base. The TSPs are coordinated from the host VAX, which in our case is a VAX Cluster.

The host maintains a dictionary that is used for compression of text; it also maintains the uncompressed text files. Compressed versions of the text are stored in the TSPs. A TSP can conduct rapid searches of compressed text; about 5 minutes is required for a 300 Megabyte search. The architecture of the system is

such that regardless of the size of the data base, a search is completed in 5 minutes. This is because all TSPs work in parallel and all the disks on a TSP are read in parallel.

The architecture is illustrated in figure 2-9.

Interfaces to the data bases are handled through several system components

The data base icon on the workstation is being developed to transfer documents to the Text Search Machine.

Query, report writing and forms control packages that come with VAX Rdb/VMS are used in the VT100 terminal emulation window to control the data in the structured data bases.

Custom software is being developed to enhance the query and report writing capabilities of the text search machines.

The terminal emulation and file transfer with the VAX computer are accomplished with EVMS (from Xerox). EVMS is the hardware and software interface between VAX/VMS and Xerox products running the XNS (Xerox Network System) protocols.

2.9 HEADQUARTERS COMMUNICATIONS

Facility for headquarters communications is provided by the following system components (Refer to "HQ Unclassified Systems Architecture", Figures 2-4 and 2-5.)

- Commo Workstation
- Wire Service Workstations
- Autodin Mail Gateway
- Autodin Interface.

Operation of the Wire Service is controlled by the Wire Service Editors using their workstations to select material for distribution to the consumers. Once selected, material is sent electronically via

XEROX

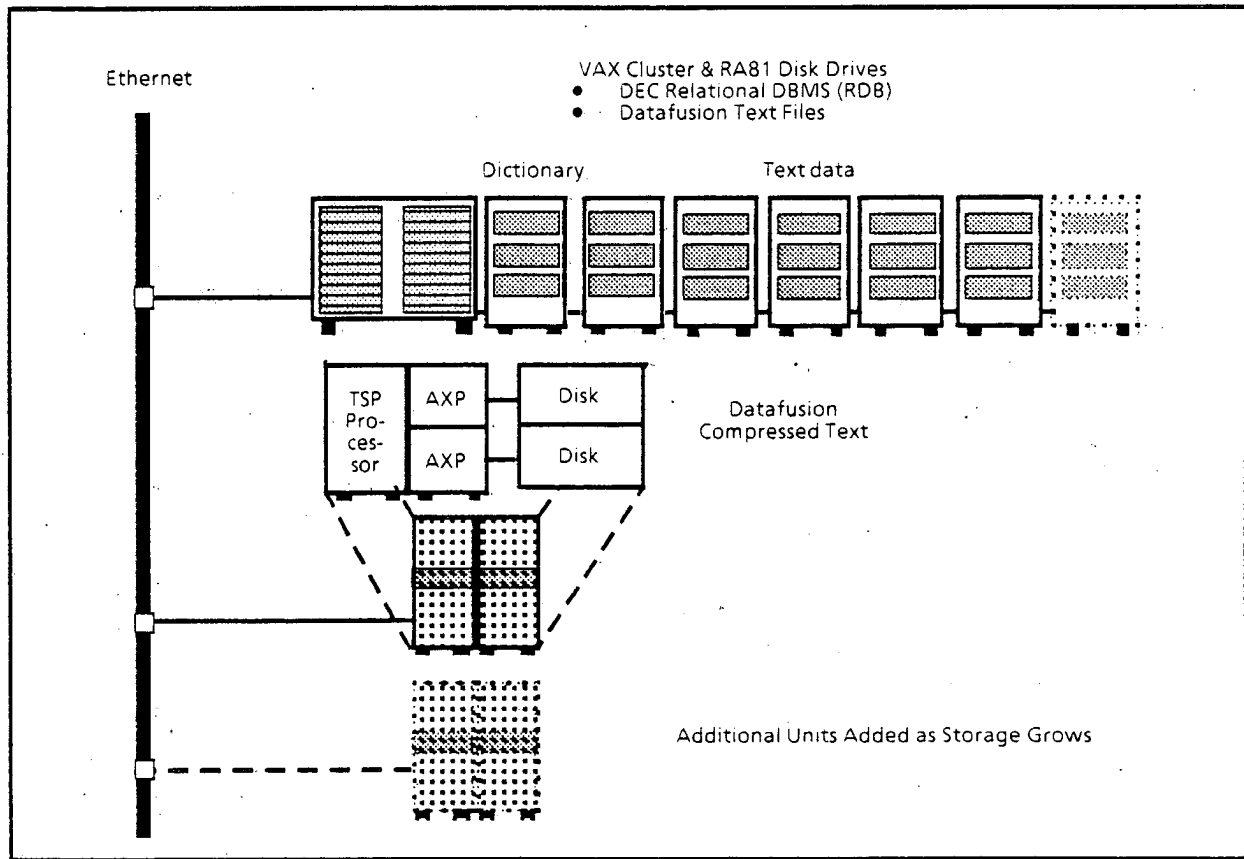

Figure 2-9 Datafusion Distributed-Database Architecture

the net to the Wire Service Gateway. This Gateway, running unattended, queues the outgoing messages for transmission via the comm interfaces to the proper consumer circuits.

Facility for two-way communications with Independent Contractors is provided within JPRS

through the use of a PC which is interfaced to telephone lines with a Modem and to the local network for distribution without rekeying.

The remaining Communication Components function in the same way as they do in the Bureaus, described in Section 2.5.

XEROX**SECTION 3****FUNCTIONAL INTERFACES****3.1 INTERNAL INTERFACES****3.1.1 Bureau Workstation--Collection Control**

Control of the collection subsystem is exercised through the use of four workstation interfaces:

- Monitor workstation receiver control interface,
- Boardman operator schedule control interface,
- Cruiser DBMS interface, and
- Boardman DBMS interface.

3.1.1.1 Monitor Workstation Receiver Control Interface

Display and control of the receiver parameters, e.g. frequency, gain, bandwidth, etc., is provided through a special window on the Monitor's workstation. An illustrative example of the window is shown in Figure 3-1. As can be seen, control of all receiver parameters is provided. Note that the equipment selection, such as antenna and receiver, can be changed by the Monitor only with Boardman operator concurrence to avoid conflicts in the assignment of resources.

To change a parameter the Monitor moves the cursor with the mouse to the desired value and "clicks" the mouse button. The value selected will immediately change on the display from black-on-white to black-on-gray to indicate that new value has been recognized and is in the process of being changed. The previously selected value will remain shown as white-on-black to indicate that this is the value being used by the system in operation. When the system has

in fact been changed to the new value, the occurrence will be confirmed to the Monitor by changing the black-on-gray displayed value to white-on-black and the previously selected white-on-black value will be changed to black-on-white as are the other non-selected values.

When a new value is selected, or other action requested, the Monitor's workstation sends a message over the net to the DBMS-VAX where after appropriate format conversion it is forwarded via the DECNET connection to the Boardman system in the Radio room (or remote site). The Boardman computer receives the request and issues a command via the IEEE-488 bus to the correct receiver to change the value. When confirmation is received from the receiver the Boardman computer updates its parameter file and sends a confirmation message back to the Monitor workstation via the DBMS-VAX. Upon receipt of the confirmation message the Monitor workstation updates the screen display to indicate that the requested action has been completed.

3.1.1.2 Boardman Operator Schedule Control Interface

Scheduling of the collection equipment, i.e., antennas, receivers, recorders, etc., is controlled by the Boardman computer (MicroVAX) in the Radio room. The operator exercises the control by interacting with the Boardman computer terminal which has special screen displays depicting the schedule, resources, network, etc..

System operation begins with the Boardman operator using the Terminal of the MicroVax computer to retrieve the proper Boardman file from the bureau DBMS computer via the DECNET

XEROX

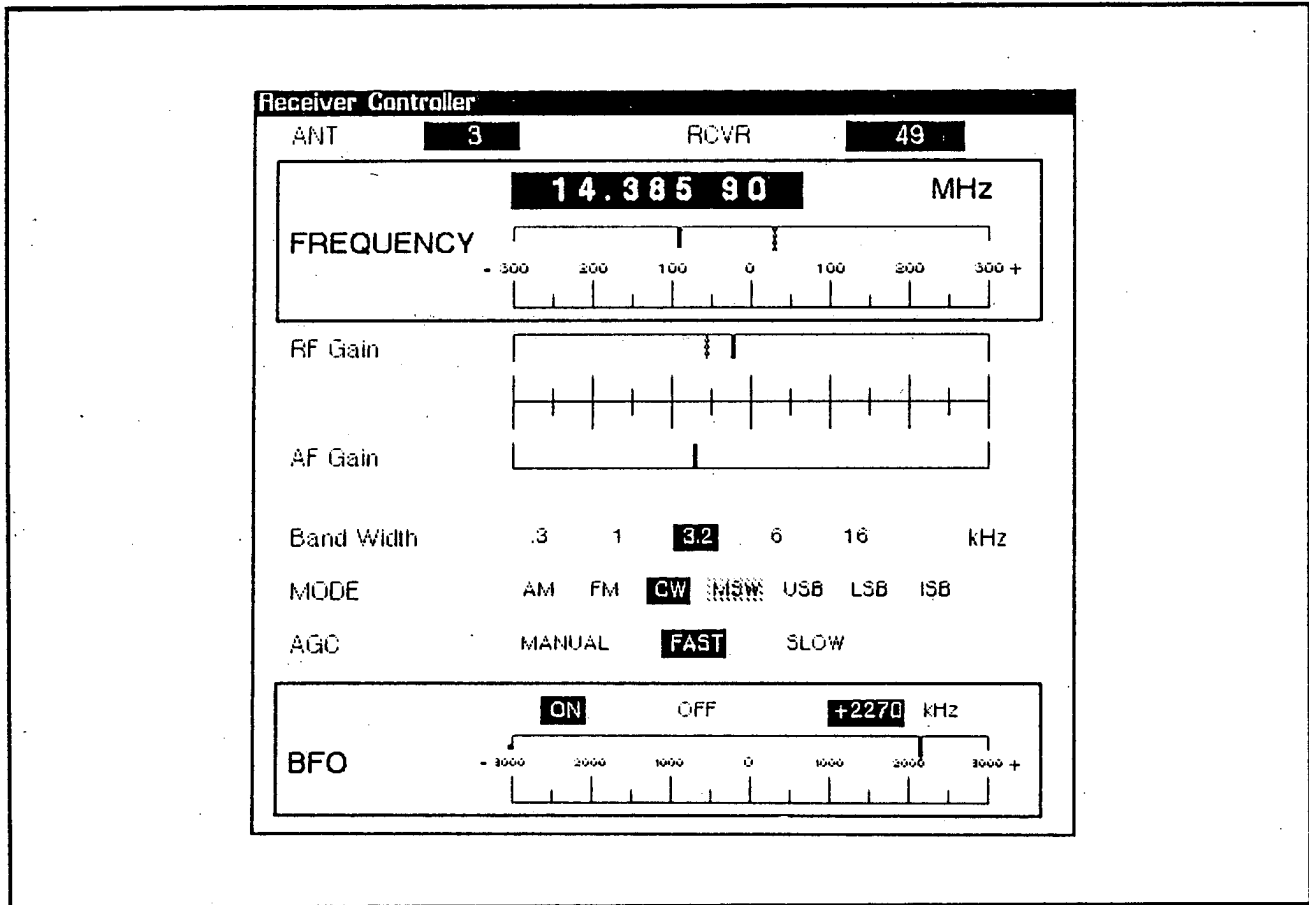

Figure 3-1 Receiver Control

connection. Then, again using the Terminal, the operator modifies the schedule, if required, and assigns specific equipment to the schedule items. Software assistance is provided to the operator in terms of equipment compatibility and usage inventory. In addition, software is provided to allow the operator at any time to examine and modify the schedule or equipment assignment and to observe and diagnosis system operations.

When the initial schedule has been obtained from the DBMS computer and edited, the subsystem is placed in operation to control the switching of equipment and the receiver parameter control. Further modification of the schedule or resource assignment can be accomplished in the background while the subsystem is continuing operation. New

assignments will be initiated when entry is complete, or when scheduled, without interruption of the operation.

3.1.1.3 Cruiser DBMS Interface

Entry of Cruiser data into the DBMS is accomplished through the use of a special window on the Cruiser's workstation. The window will be similar to the one illustrated for the Monitor's workstation except that it will be tailored to the entry of data into the DBMS. Some of the necessary data such as receiver frequency, date/time, etc. will be retrieved by the workstation from the system and entered into the form automatically. Other data such as source, language, etc. will be entered by the Cruiser into labeled blanks provided in the form. When the data is complete the Cruiser "bugs"

XEROX

ENTER with the mouse and the data is sent to the DBMS-VAX for filing. Note that the form is set up so that key fields may not be omitted; a warning is issued and transmission is refused. Likewise, fields that should be numeric, e.g., frequency, etc., will *forcefully* resist the entry of alphabetic data. This, of course, is a common characteristic of all of the interface forms.

Editing of the data after entry, but before transmission to the DBMS, is accomplished using the mouse-directed INSERT, DELETE, COPY and MOVE procedures in the standard Star manner. Editing of data in the DBMS can only be done by retrieving the file, editing in the above manner and re-entering the file into the DBMS. Only users given "modification" privilege may perform this operation and then only on files to which they have been granted the privilege.

3.1.1.4 Boardman DBMS Interface

Access to the DBMS by the Boardman operator is provided through the use of special forms displayed on the Boardman computer (MicroVAX) terminal. Operation is quite similar to the use of the other screen interfaces in that it is largely a matter of filling out forms. The operator may recall schedule data for use by the Boardman computer in scheduling the system and may also modify existing data in the DBMS. Entry of the performance data after the schedule has been exercised is accomplished automatically by the Boardman computer by unattended communications with the DBMS-VAX.

3.1.2 Bureau Workstation--Data Base Operations

The bureau data base operations functional interfaces are divided into three areas, entering data, manipulating data and reporting on data.

There are three ways that data is entered into the data bases:

Data is automatically added to the textual data base as it is either received or sent by the

communications operator. English language press agency is also automatically added to the textual data base.

An editor or other operator at a workstation can add a document to the textual data base. This is done by moving icons on the workstation screen. The icon representing that document is moved to a **new data base icon**. This action at the workstation causes the document to be added to the data base, and optionally causes a property sheet to appear on the screen to be filled out. An example of what such a property sheet might look like is shown in figure 3-2. Administrators and others that are interested in entering data to the structured data bases use a **VT100 terminal emulation window** on a workstation. This is a window that acts just as if it were a VT100 terminal on the VAX computer. Within this window, the specific Rdb and BASIS utilities that access the data base will be activated.

In addition to adding data to the data base, there is a need to be able to modify and query the data base after it is already entered.

DB X'FR Properties		
Done	Cancel	Apply
Icon Name	XINHUA	
Data Base Name	VAX:XINHUA.DB	
File Name in DB	File Name on Desktop	
Associated Text	^	
Associated Commands	^	
On Document Transfer	Display Options	

Figure 3-2. Document Transfer Form

XEROX

The person acting as system administrator of the data base uses a VT100 terminal emulation window on a workstation to maintain the data base. In the terminal emulation window, the user has access to all the VAX, Rdb and BASIS utilities. This window is used just as if it were a VT100 connected to the VAX computer.

The people accessing the structured data bases have need to query and edit records. This is accomplished by applications written in the forms control language of either Rdb or BASIS. These applications will run in a VT100 terminal emulation window on the workstation. There are also requirements to be able to write reports based on data in the data bases.

People accessing the structured data bases will use either DATATRIEVE (from Digital) or the REPORT module of BASIS (from Battelle). Both of these modules allow the user to access the data base and format reports. These applications will run in a VT100 terminal emulation window on the workstation.

The workstation communicates with the VAX through the Ethernet and the XNS protocols. The package that implements this interface on the VAX is EVMS. This package allows the transfer of file between workstations and VAXs and the emulation of VT100 terminals on the workstations. These emulations are indistinguishable from real terminals by the VAX applications.

To allow for a common user interface to the data bases, some common "front end" screens will be developed. These screens will make it appear to the user that there is only one data base management system.

3.1.3 Bureau Workstation--Running Summary

The Running Summary interface provides the means for one monitor to be creating a running summary of a live speech, while editors and other monitors can view and use the contents of

the running summary while it is being created. The multiple window displays for monitors and editors operating in this mode is shown in Figure 3-3.

For a given session, a single designated workstation/user is permitted to write into the running summary file on a continuous basis. Other workstations/users may view any or all pages of the running summary file, except the one currently being written by the designated workstation/user, but may not write on the file; full scrolling capabilities must be available to these users. After the designated user logs-off at the conclusion of the session, the running summary file remains until specifically deleted by the responsible editor. Specifics such as the identities of the designated user for writing, the responsible editor for deletion, and the file name are set up on each occasion prior to starting the running summary.

Monitors and editors use terminal emulation windows on their workstations for creating, viewing, and using the running summary. The running summary itself is located on the host computer (on the network) which is also used for the database and collection control activities. The workstations appear to the host as if they are generic TTY-like terminals (e.g. VT100s).

3.1.4 Headquarters Workstation--Data Base Operations

The headquarters data base operations functional interfaces are also divided into three areas, entering data, manipulating data and reporting on data. The differences between the headquarters and bureau data base operations and differences of scale. The system design was impacted by the size of the database at the headquarters.

Another difference is that there are security considerations at the headquarters that do not exist at the field bureaus. To satisfy the security considerations, there will be two functionally

XEROX

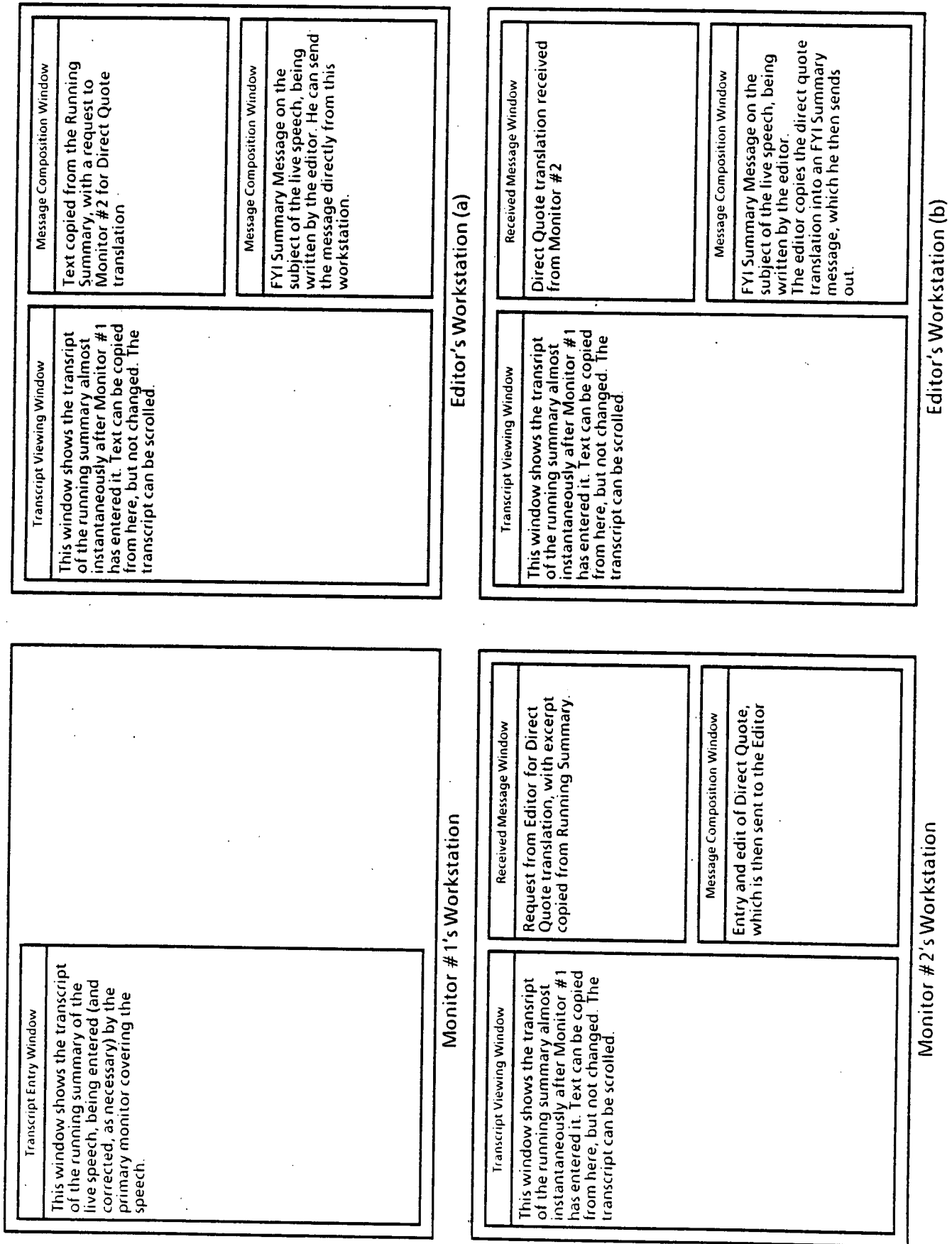

Figure 3-3. Monitor/Editor Screens for Live Speech

XEROX

identical systems, one open and one secure. The same software will run on both systems and the product data base will be replicated on each system. The primary difference is the number of users and the use of the Tempest versions of the equipment.

There are three ways that data is entered into the data bases:

Data is automatically added to the textual data base as it is composed for the photo typesetters. This means that there is no operator intervention to get the product into the data base.

An analyst or other operator at a workstation can add a document to the textual data base. This is done by moving icons on the workstation screen. The icon representing that document is moved to a new data base icon. This action at the workstation causes the document to be added to the data base, and optionally causes a property sheet to appear on the screen to be filled out. An example of what such a property sheet might look like is in figure 3-2

The Associated Text field is for entering the themes and categories for the PASKEY file.

Administrators and others that are interested in entering data to the structured data bases use a VT100 terminal emulation window on a workstation. This is a window that acts just as if it were a VT100 terminal on the VAX computer. Within this window, the specific Rdb and Datafusion utilities that access the data base will be activated.

In addition to adding data to the data base, there is a need to be able to modify and query the data base after it is already entered.

The person acting as system administrator of the data base uses a VT100 terminal emulation window on a workstation to maintain the data base. In the terminal emulation window, the user has access to all the VAX, Rdb and Datafusion utilities. This window is used just as if

it was a VT100 that was connected to the VAX computer.

The people accessing the structured data bases have need to query and edit records. This is accomplished by applications written in the forms control language for the VAX. These applications will run in a VT100 terminal emulation window on the workstation.

There are also requirements to be able to write reports based on data in the data bases.

People accessing the structured data bases will use DATATRIEVE (from Digital) to access Rdb files. Application software will be written to report on the Datafusion files. Both of these modules allow the user to access the data base and format reports. These applications will run in a VT100 terminal emulation window on the workstation.

The workstation communicates with the VAX through the Ethernet and the XNS protocols. The package that implements this interface on the VAX is EVMS. This package allows the transfer of file between workstations and VAXs and the emulation of VT100 terminals on the workstations. These emulations are indistinguishable from real terminals by the VAX applications.

To allow for a common user interface to the data bases, some common "front end" screens will be developed. These screens will make it appear to the user that there is only one data base management system.

3.1.5 Headquarters Workstation--Writer's Workbench

The Writer's Workbench functions are accessed from the workstation. Documents that are to be analyzed by the Writer's Workbench are sent to a special service we are calling the Writer's Workbench Service. The document is then analyzed by the Writer's Workbench and the

XEROX

results are deposited in a file on the Writer's Workbench Server for the requester to retrieve at his convenience.

The documents are sent to the Writer's Workbench Service by copying the document icon (at the workstation) to the icon representing the Writer's Workbench Service. After the document is copied, a window will appear to allow the requester to fill in the associated commands. An example of what such a window might look like is in figure 3-2.

The requester will fill in the associated commands field to specify what analysis the Writer's Workbench should do.

3.1.6 Receiver--Communications Interface Unit (RTTY)

Press Agency traffic in RTTY form is scheduled by the Boardman computer system in the same manner as other Monitor reception. The computer selects the appropriate antenna for the receiver, sets the receiver frequency and other parameters and switches the output of the receiver to the proper FSK Demod unit. The Demod units are wired directly to one of the RS232C ports of the Communications Interface Units. These ports are associated by means of the Services software with specific Press Agency directories on the News Service. Each separate incoming item is placed in its directory, and parsed to determine its source, date and time, and subject slug. These attributes are used to enter the item into the Table of Contents for that Press Agency directory.

The operation is entirely computer controlled; no operator intervention is required other than the normal Boardman scheduling.

3.2 EXTERNAL INTERFACES

3.2.1 Wire Service

Operation of the Wire Service is controlled by the Wire Service Editors using their workstations to select material for distribution to the consumers.

Once selected, material is sent electronically via the net to the Wire Service Gateway. This Gateway, running unattended, queues the outgoing messages for transmission via the comm interfaces to the proper consumer circuits.

The Wire Service Editor's interface with the workstation does not involve any special practices, but rather use of the standard Star workstation features. Editing, if desired, is accomplished using the mouse-directed INSERT, DELETE, COPY and MOVE procedures. Selection and transmission is accomplished by mouse-selecting from prepared lists of addressees and actions.

3.2.2 Landline--Communications Interface Unit (Press Agency)

Both landline and RTTY Press Agency feeds are connected to RS232C ports on Communications Interface Units. These ports are associated by means of the Services software with specific Press Agency directories on the News Service. Each separate incoming item is placed in its directory, and parsed to determine its source, date and time, and subject slug. These attributes are used to enter the item into the Table of Contents for that Press Agency directory.

3.2.3 Bureau Communications Links (Autodin, etc.)

All outgoing traffic is routed to the Commo Workstation from the Slot Editor. The Commo Operator checks the format, adds additional header information as necessary and forwards the traffic to the Autodin Mail Gateway.

The Autodin Mail Gateway is a stand-alone server on the local network. It receives all outgoing traffic from the Commo Workstation and provides the queueing, precedence handling, error checking, logging and filing functions. After completion of processing outgoing traffic is released to the Autodin Interface for transmission. In addition the Gateway receives all incoming traffic from the Autodin Interface.

XEROX

Again, the functions of queueing, precedence handling, error checking, logging and filing are provided for the incoming traffic. The incoming traffic is then routed to the appropriate mailbox and alerts issued if indicated by precedence. Note that Commo Operator intervention is not required for incoming traffic.

The Autodin Interface serves as the bridge between the generic form of the traffic within the local network and the specific protocols of the various communications links. Autodin Modes I and V, DOS Comsat, DTS, DCS and Telex protocols are provided.

Two user interfaces are involved; (1) the Slot Editor and workstation, and (2) the Commo Operator and workstation. Use of the Slot Editor workstation only involves use of the normal Star editing and mail handling facilities. The Commo Operator on the other hand has special forms associated with that workstation to provide such capabilities as address-list access, message log access, etc.. The actual operation however still involves use of the standard mouse-directed tools used on all workstations.

3.2.4 Phototypesetter

The phototypesetter interface is provided by means of the communications port on a specialized version of the network Print Service. If the typesetter is co-located with the "Typesetter" Print Server, a simple RS232C connection

is required. A remotely located typesetter is interfaced using Modems and a communications link between the communications ports. (If the distance is less than 15 miles, and a dedicated circuit is used, Line-Drivers can be used in place of Modems.)

On the workstation, the document to be typeset is converted into standard print-file format, just as if it were to be sent to a standard network printer. On a standard network Print Service (such as is used for producing proof copy), the print-file format is decomposed and turned into instructions for the laser printer. On the "Typesetter" Print Service, the print-file format is decomposed, and turned into instructions for the typesetter, including insertion of all necessary typesetter composition codes. The procedure at the workstation is identical in each case; the user never has to enter any explicit typesetter composition codes into the document.

A special requirement of using a phototypesetter, which is transparent to the user at the workstation, is that the software on the workstation which produces the print-file must have access to the character metrics (such as widths) of the fonts used on the particular phototypesetter which is interfaced to the "Typesetter" Print Server. This is taken care of during the workstation installation process.

XEROX

SECTION 4

PROCESS FLOWS

4.1 FBIS OVERALL OPERATIONS

This section of the Concept of Operations graphically shows the logical processes which will occur within the modernized, areas of FBIS using the Structured Systems Analysis technique of Data Flow Diagrams. (The term Data Flow Diagrams does not imply that the technique is useful only for computer operations: they serve very nicely for documenting existing paper-based operations, as well as those of *systems* which are computer-assisted, but depend largely on people for their overall operation.)

Figure 4-1 shows the 'Level 0' Data Flow Diagram of the area of FBIS covered in this narrative. It serves to show the general flow of information through FBIS, from collection to publication, as well as to show the information and published product flows from one Group to another within FBIS. This Level 0 diagram serves to provide a context for the Level 1 diagrams which follow, and to show how the Level 1 diagrams tie together.

4.2 FIELD BUREAU OPERATIONS

The FBIS Field Bureaus collect the raw data from foreign broadcasts, press agency transmissions, and publications, review the material for its publishability, produce summaries and translations (where applicable) of selected materials, and transmit the resulting summaries and translations to FBIS Headquarters and other interested parties. This process is shown in the Field Bureau Data Flow Diagram, Figure 4-2.

Collection of Radio and TV Broadcast information is governed by the listing of scheduled times and frequencies contained in the Boardman File. Publications are received according to the listings

in the subscription file. Broadcast data is monitored as it is being received, and recorded on magnetic tape for later possible translation and temporary retention. All such captured information is distributed, internal to the Field Bureau, to the appropriate monitors for their review. In many cases, this "distribution" takes place *a priori*, in that the appropriate monitors listen to and record the broadcasts.

Character-oriented Press Agency wire transmissions (most of which are now transmitted digitally) are captured in electronic form, and stored in specific directories of a 'News Service', which produces listings of the traffic by date-and-time, subject heading ('slug'), priority, etc. Such traffic is available for reading by the appropriate monitors or editors. Copy is not removed from the directory on the News Service by the act of reading or editing it, but remains for others to peruse. Periodically, the copy is printed out to be available for read-in, and moved to the database for its 30 or 60 day retention. (A similar approach is used on the Mail Service for reading and making available outgoing traffic, drop copy, and administrative messages.) Ideographic Press Agency copy is captured in hardcopy form, and monitored in the printed form, as are the received publications. Vernacular Press Agency copy can be monitored either on the display screen or in printed form, at the user's discretion. English language copy is handled directly on the screen by the Editor.

During the news broadcasts, the monitor at his workstation produces draft (English language) summaries of the items, which he then forwards to the editor using electronic mail. The monitor retains or forwards the sources of these items for

XEROX

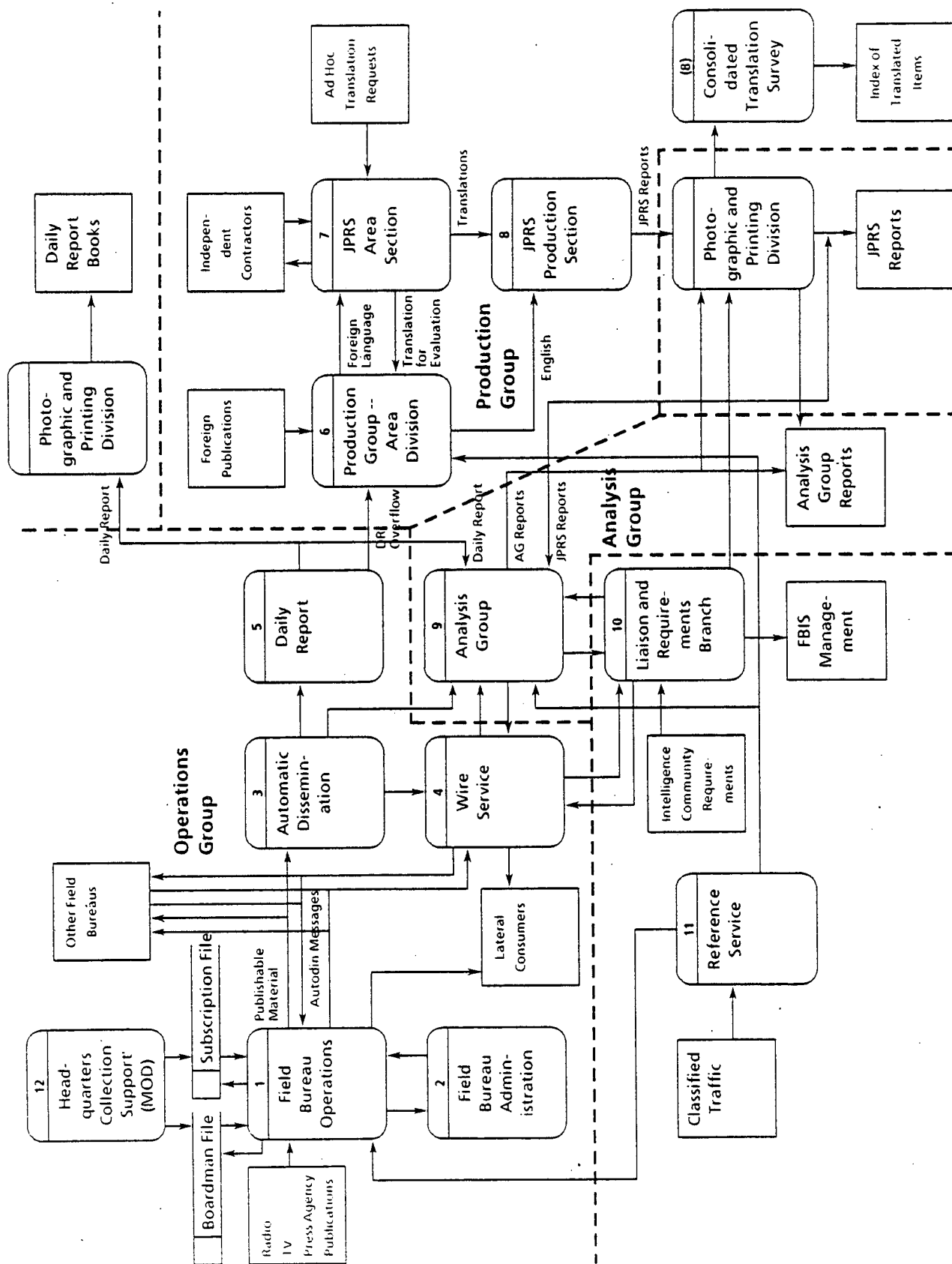

Figure 4-1. FBIS Overall Data Flow Diagram

XEROX

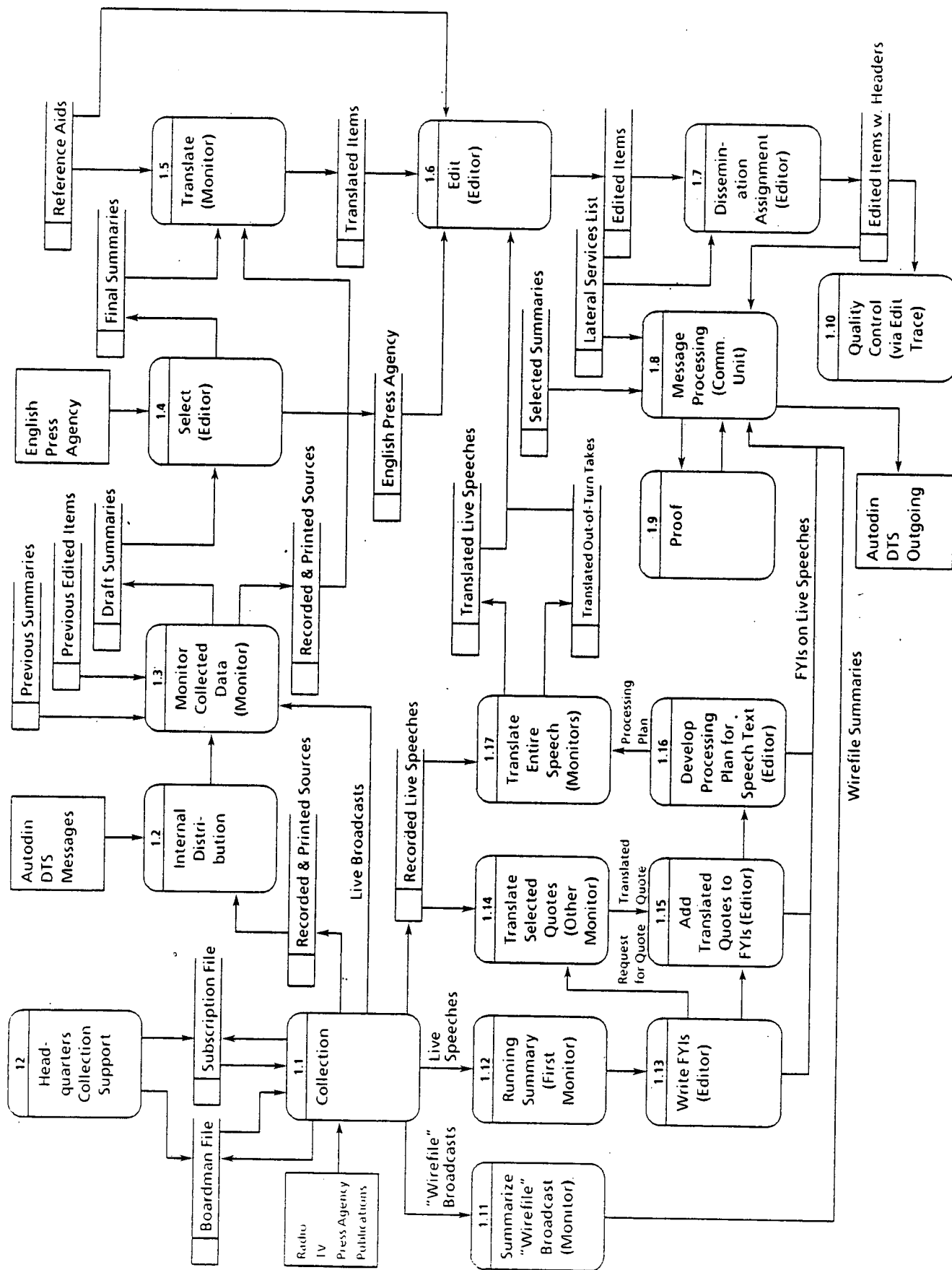

Figure 4-2. Field Bureau Data Flow Diagram

XEROX

translation, as required. Summaries, and Press Agency copy which originated in English, are reviewed on the workstation by an editor. In determining whether particular items are of interest for translation, the editor uses the printed read-in copy and the archives in the database to review previous summaries and edited items which have been created at this and other bureaus. Certain broadcast summaries, typically of a broadcast review of the day's editorials, known as "wirefile" are sent out over the wire to FBIS Headquarters directly, although the full-text of a wirefile item may well be selected for full translation later.

Selected summary items are translated (from the original source which had been summarized), with the translation being entered directly onto the workstation. Translated items are forwarded by electronic mail to the editing process, where they are reviewed for accuracy and quality of translation, and edited as required. Copy can be printed at any time for review and discussion. Selected English Press Agency copy is processed directly by the editor. After editing the text of the publishable message, the editor adds notations as to the precedence, subject area, and general classes of recipients of the message. He then forwards the message by electronic mail to the communications operator, who expands the suggested recipient lists into actual address headers for each recipient. A quality control cycle uses the source and edited materials, along with an edit trace, for training monitors and editors to the standards of FBIS. The edit trace shows all edits which take place between successive versions of a translation. The edits within this edit trace can be viewed, or suppressed, at the user's command.

Completed items are disseminated according to the requirements of the Lateral Services list, with all items forwarded over the available communications links to FBIS Headquarters and the Lateral Consumers. Outgoing messages go

through a proofing cycle before transmission, at the same time as the communications operator is expanding and combining the addressee lists using the facilities of his workstation. Precedence management, and control of the outgoing message queues, takes place by means of the Autodin Mail Gateway, and operator interaction as required.

Coverage of live broadcasts of major speeches requires a somewhat different procedure. Here, a primary monitor creates a running summary of the speech (and beginning announcements), which is written into a transcript file on the host computer. The transcripts of running summaries are available for quasi-real time viewing, scrolling and copying at other workstations. The editor, viewing the running summary sends out periodic "FYI" messages to Headquarters, summarizing what has occurred so far, and occasionally asks another monitor who is also monitoring and recording the speech (and viewing the running summary) to produce translations of direct quotes from the speech for inclusion in the FYIs. At the conclusion of the speech, the editor sends his "processing plan" in the final FYI. The full-text of the speech is then translated, with important items done first as "out-of-turn takes", and the rest following later, and all of it is sent out to Headquarters and the usual sets of Lateral Consumers. When everything is processed, the running summary is moved to the database for temporary retention.

4.3 FIELD BUREAU ADMINISTRATION

Field Bureau administration personnel have word processing and database access capabilities provided at workstations on the same network as the monitors and editors. The database query and report generation software provides most of the functionality needed for Bureau administration purposes.

XEROX

4.4 AUTOMATIC DISSEMINATION

Incoming copy from the Field Bureaus, Operational message traffic to and from the Field Bureaus, and outgoing copy to FBIS Wire consumers of the FBIS product all pass through the Wire Service. Incoming copy which is intended for the Daily Report (as well as possible forwarding to Wire Service consumers) is forwarded directly into the Daily Report operation. (In fact, *all* publishable messages go to the Wire Service, the Daily Report, and the Analysis Group.)

4.5 FBIS WIRE SERVICES

Incoming traffic from the Autodin system is stored for the record, and sorted according to its Precedence setting into Routine, Priority, Immediate, and Flash queues. An editor sifts through the messages in the queues, according to priority, and sorts them into a number of categories, as shown on the Wire Service Data Flow Diagram, figure 4-3. Messages which are deemed to be of interest to FBIS Wire consumers are edited, and queued for transmission. A complete log of all messages transmitted to Wire Service consumers is also kept.

Operational and administrative messages pass through an operational editing cycle, along with such messages originating within FBIS Headquarters. These messages are then transmitted to the appropriate Field Bureaus, as well as stored for the record and later possible retrieval. Wire Service and message traffic is printed periodically to be available for read-in.

4.6 DAILY REPORT

Incoming copy is received from the Field Bureaus through the Autodin communications network and other communications links. All copy intended for one of the eight books is routed directly to a Mail Service, where it is sorted for delivery to various groups, as shown on the Daily Report Data Flow Diagram, figure 4-4. (Incoming

messages tagged "Only" are routed only to the addressee.)

Copy intended for one of the Daily Report books is disseminated to the appropriate section. The Mail Service uses the information which was placed in the message headers at the Bureaus to determine the dissemination to this level. Each section of each of the books of the Daily Report has its own directory (a "well-known" mailbox) on the Mail Service. Dissemination beyond the section level is handled by a workstation user, who peruses the contents of the well-known mailbox, and forwards material appropriately. Copy for a Daily Report book is reviewed by an Editor to see if it should be published (immediately or later), if it should be sent to the Joint Publications Research Service for publishing, or if it should be discarded. Traffic which is operational in nature is edited (as necessary) and forwarded to the Wire Service.

Publishable copy is reviewed at the workstation for each book section, and items are arranged in publishing sequence. This arrangement takes place within a "File Folder" for that Book/Section/Date. The total length of the items, as shown in the listing of items in the folder, is then used to estimate the copy depth (page requirements). When there is too much copy for the available page capacity, items may either be discarded or returned to the publishable queue. Publishable copy is edited according to the FBIS Editorial Handbook. In the course of editing, a spelling check is performed on the workstation, and syntax checking, etc., is performed using a network service running Writer's Workbench™ in batch mode. Edited items are placed, in the same arrangement as before, in an appropriately labeled folder. This folder is then available for perusal by a senior editor.

Edited copy is reviewed for quality, and revised if necessary. As a part of this process, successive versions of the copy, along with an edit trace of the changes made along the way, are used to

XEROX

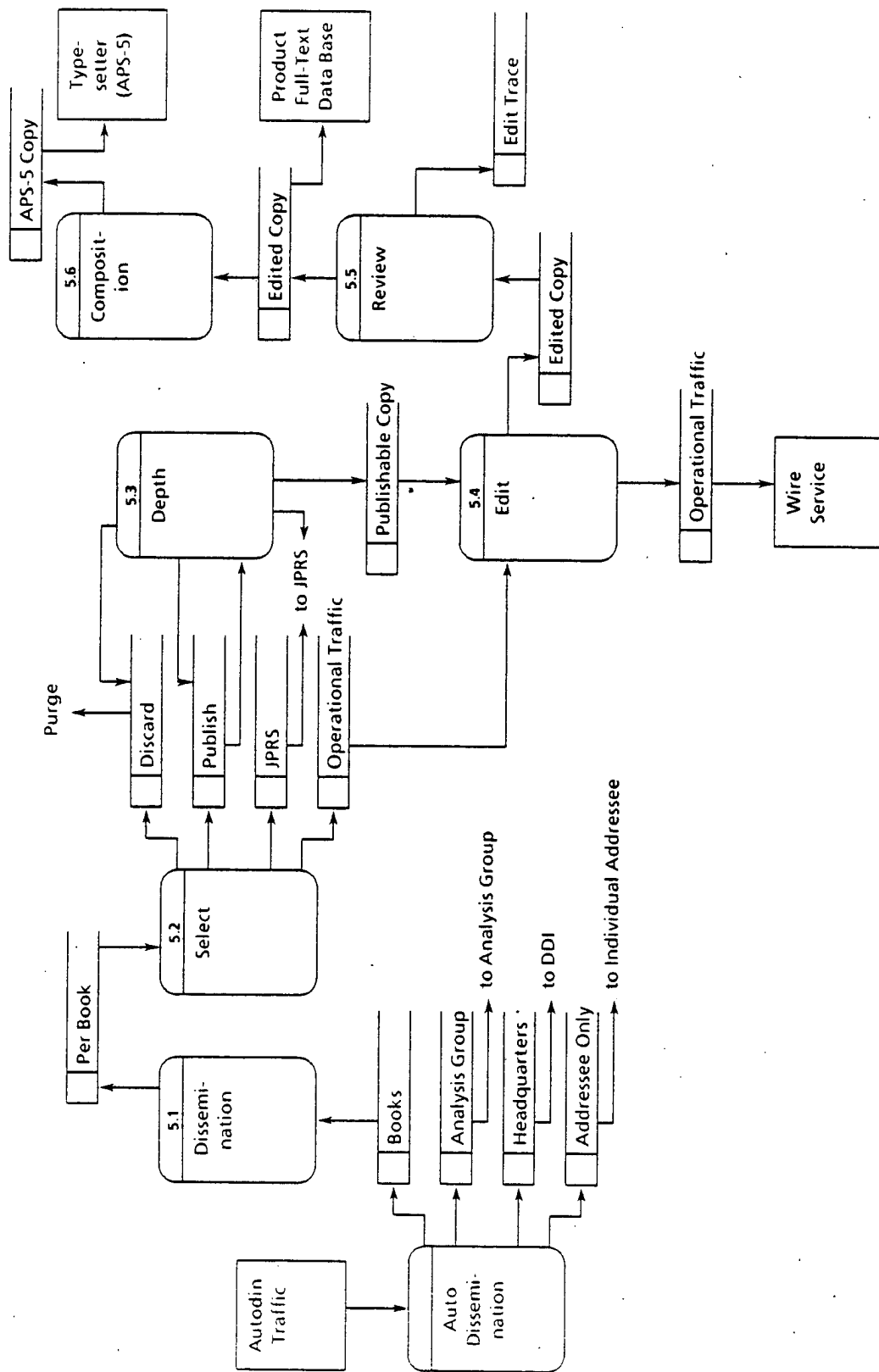

Figure 4-4. Daily Report Data Flow Diagram

XEROX

provide feedback to the editors as to their performance, which improves quality control and assists in the training of new editors. The edits within this edit trace can be viewed, or suppressed, at the user's command. Final versions of the items in a book section are placed in a final folder, ready for composition of the section and book.

Composition for each book takes place in batch/background mode, using the contents of each section's folder in turn. During composition, a list of recalcitrant pages which do not fit the page design criteria is produced. These problem pages can then be adjusted interactively; re-composition, if necessary, starts from the point of the problem, leaving earlier pages untouched. When the composition pass is complete, and all corrections have been made, Tables of Contents and Indexes are produced. Final edited and composed books/sections are deposited in the full-text product database, along with the TOCs and Indexes.

For typesetting, the folder containing a finished composed book with its front and back matter is moved to the "Typesetter Service", where composed books are automatically converted to phototypesetter format and delivered to the phototypesetter electronically. Since this process takes place using a network service, the phototypesetter composition codes are never present in the document(s) on the workstation, and do not have to be explicitly entered by anyone.

4.7 PRODUCTION GROUP: AREA DIVISION

The major activity of an Area Division Analyst is scanning foreign source material, and selecting items for translation. Usually, these items will be forwarded to the JPRS Area Section for processing and translation, but a small fraction of the material is considered sufficiently timely that the Area Division Analyst will translate it. Area Division data flow is shown in Figure 4-5. English-language material published in foreign

sources is forwarded directly to the JPRS Publications Section. All items forwarded to JPRS are accompanied by a CSO Card. (The acronym stands for Contract Services Order.) Note that a physical "Card" is required, even though Contract Service Orders are entered on a workstation and manipulated in the Management Information System portion of the DBMS, since the source material itself is in hardcopy form at this point in the flow. Translated items are keyboarded on the workstation during translation, and are thus sent to JPRS in electronic form, along with a CSO database reference.

Area Division Analysts may be asked to respond to "ad hoc" translation requests received (by the Translation Services Staff) from FBIS customers, where the material to be translated falls in the particular analyst's field of expertise. These translation requests are forwarded to the JPRS Area Section, in the normal manner. Many of these, and similar, requests are received in classified messages from agency computers. This classified message traffic is handled using shared workstations on the classified system.

Translated items which had been sent in from the Field as Publishable Material, but which had not been published in a Daily Report (for a variety of reasons) are also handled by Production Group. Daily Report overflow material is received and processed in electronic form. These items are already in English, and are thus forwarded electronically to the JPRS Publications section, along with a CSO database reference.

Area Division Analysts are also responsible for producing foreign language glossaries, as aids to translation, and for evaluating the translations produced by the Independent Contractors (ICs) used by the JPRS Area Section to produce most of the translations. The Independent Contractor files are handled electronically. The glossaries, or machine aids to translation, are created and edited using multi-lingual workstations and printed using multi-lingual printers. The Data

XEROX

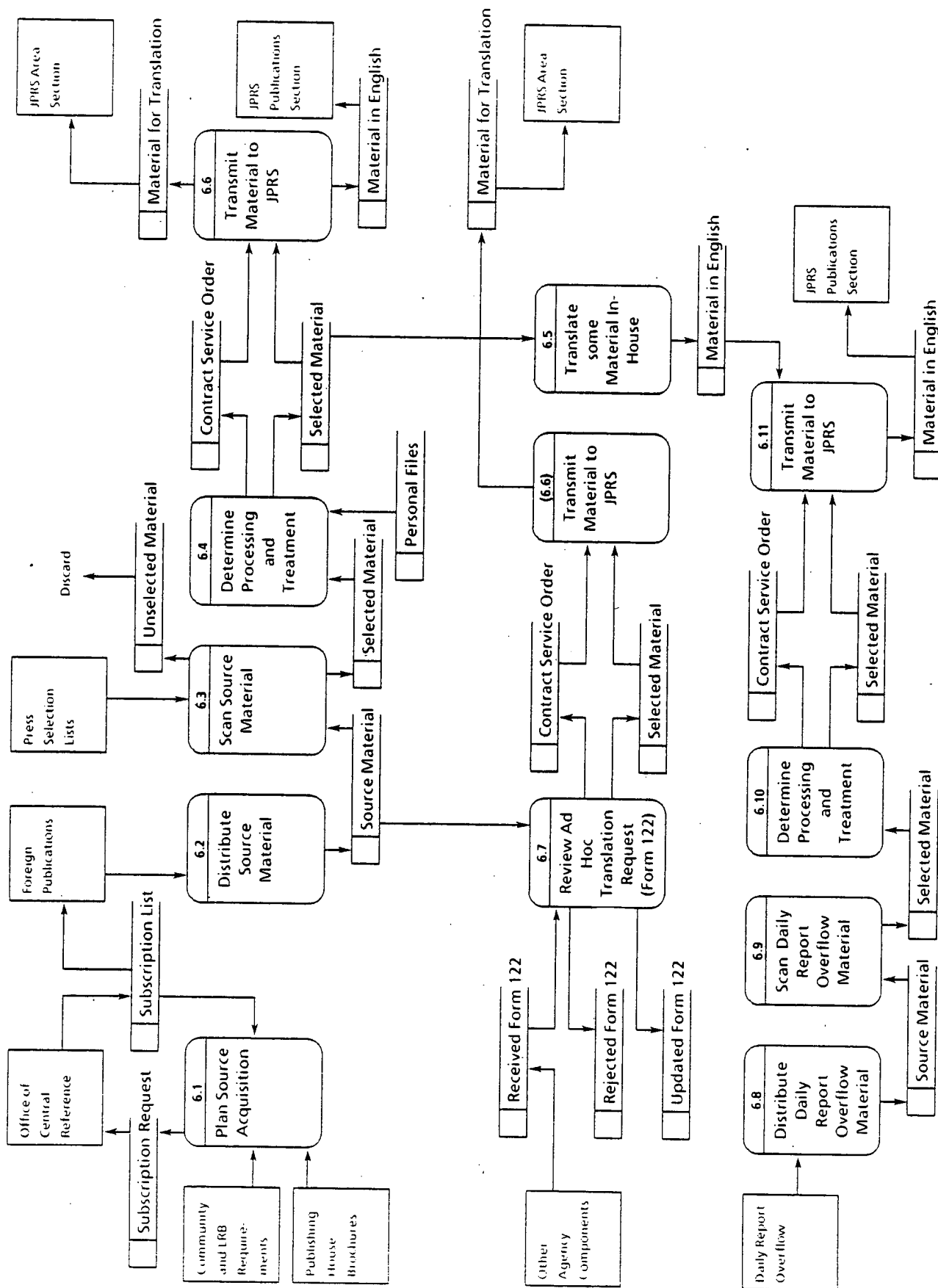

Figure 4-5. Area Division Data Flow Diagram -- I

XEROX

Flow Diagram for these activities is shown in Figure 4-6.

4.8 JOINT PUBLICATIONS RESEARCH SERVICE-AREA SECTION

The JPRS Area Sections are responsible for estimating the length of source material received for translation, selecting an IC who is appropriate for the job and is available (using the Independent Contractor files in the Management Information System portion of the DBMS), and tracking the progress of the translation after it is sent out to the IC. The Area Section is responsible for editing translations which are received back from ICs, and forwarding edited translations to the JPRS Publications Section. Completed translations will be captured electronically, so far as possible; others will be keyboarded to electronic form. Edited translations are returned to the IC for guidance purposes. Within a translation, the edits from the previous version can be viewed at the user's command, and will be present in the version returned to the IC. In the course of editing, a spelling check is performed on the workstation, and syntax checking, etc., is performed using a network service running Writer's Workbench™ in batch mode.

CSO cards or database references accompany material in process at all times. Note that a physical "Card" is required to accompany material sent to ICs, even though Contract Service Orders are entered on a workstation and manipulated in the Management Information System portion of the DBMS, since the source material itself is in hardcopy form at this point in the flow. JPRS Reference Aids are provided to ICs to assist the translation process. The Data Flow Diagram for the Area Section is shown in Figure 4-7.

4.9 JOINT PUBLICATIONS RESEARCH SERVICE-PUBLICATIONS SECTION

The Publications Section holds the material it receives until there is sufficient to warrant publishing one of the many irregular serial publications produced by JPRS. At that time, the material is collated into a report, assigned a JPRS number and date, and composed for publication. Final versions of the items in a JPRS report are placed in a final folder, ready for composition of the publication.

Composition for each report takes place in batch/background mode, using the contents of the file folder in turn. During composition, a list of recalcitrant pages which do not fit the page design criteria is produced. These problem pages can then be adjusted interactively; re-composition, if necessary, starts from the point of the problem, leaving earlier pages untouched. When the composition pass is complete, and all corrections have been made, Tables of Contents and Indexes are produced. Final edited and composed reports are deposited in the full-text product database, along with the TOCs and Indexes. The bibliographic data pertaining to the report and its contents is also entered into the Consolidated Translation Survey's Index to FBIS and other Government Agencies' Translations, maintained on the DBMS.

For typesetting, the folder containing a finished composed report with its front and back matter is moved to the "Typesetter Service", where composed reports are automatically converted to phototypesetter format and delivered to the phototypesetter electronically. Since this process takes place using a network service, the phototypesetter composition codes are never present in the document(s) on the workstation, and do not have to be explicitly entered by anyone. The Data Flow Diagram for the Publications Section is shown in Figure 4-8.

XEROX

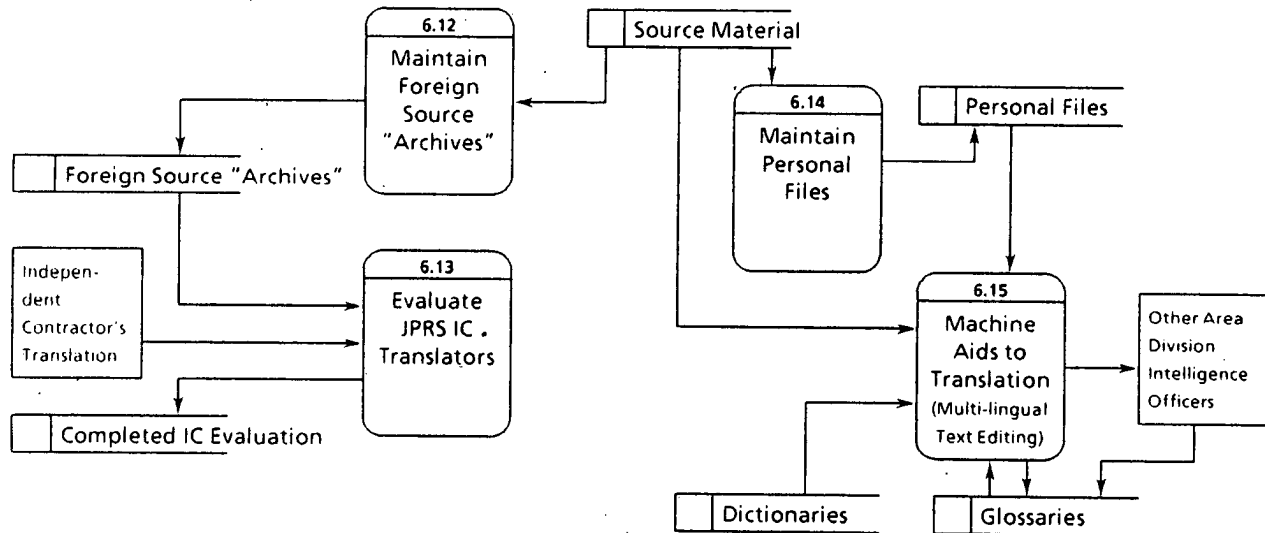

Figure 4-6. Area Division Data Flow Diagram--II

4.10 ANALYSIS GROUP

The Analysis Group differs from the rest of FBIS in some important respects. One is that it handles classified information, and thus must have a secure system. Another is that the Analysis Group looks at long-term trends in information reporting practices, and thus must make retrospective searches against files and databases of reported information and translated publications, as well as its own previous analyses.

Publishable messages from the Field are received in electronic form. These are received on the Mail Service in a "well-known" mailbox, which is processed by a designated user. Incoming messages are forwarded to individual Analysts according to their coverage profile. Published Daily Reports and JPRS Serials are available to

Analysts electronically in the full-text product database.

Analysts also receive other source material according to their coverage profile, including video tapes of foreign TV broadcasts received from the field, and all manner of foreign publications and academic journals. In addition, *classified* cable traffic is received and distributed to analysts through the Mail Service on the Classified system. Analysts review the material received, address queries to the field when clarification is required, and file selected material and field responses in their personal files. Personal files may contain both classified and unclassified material.

Individual analysts review material, create personal files, and run queries on a copy of the

XEROX

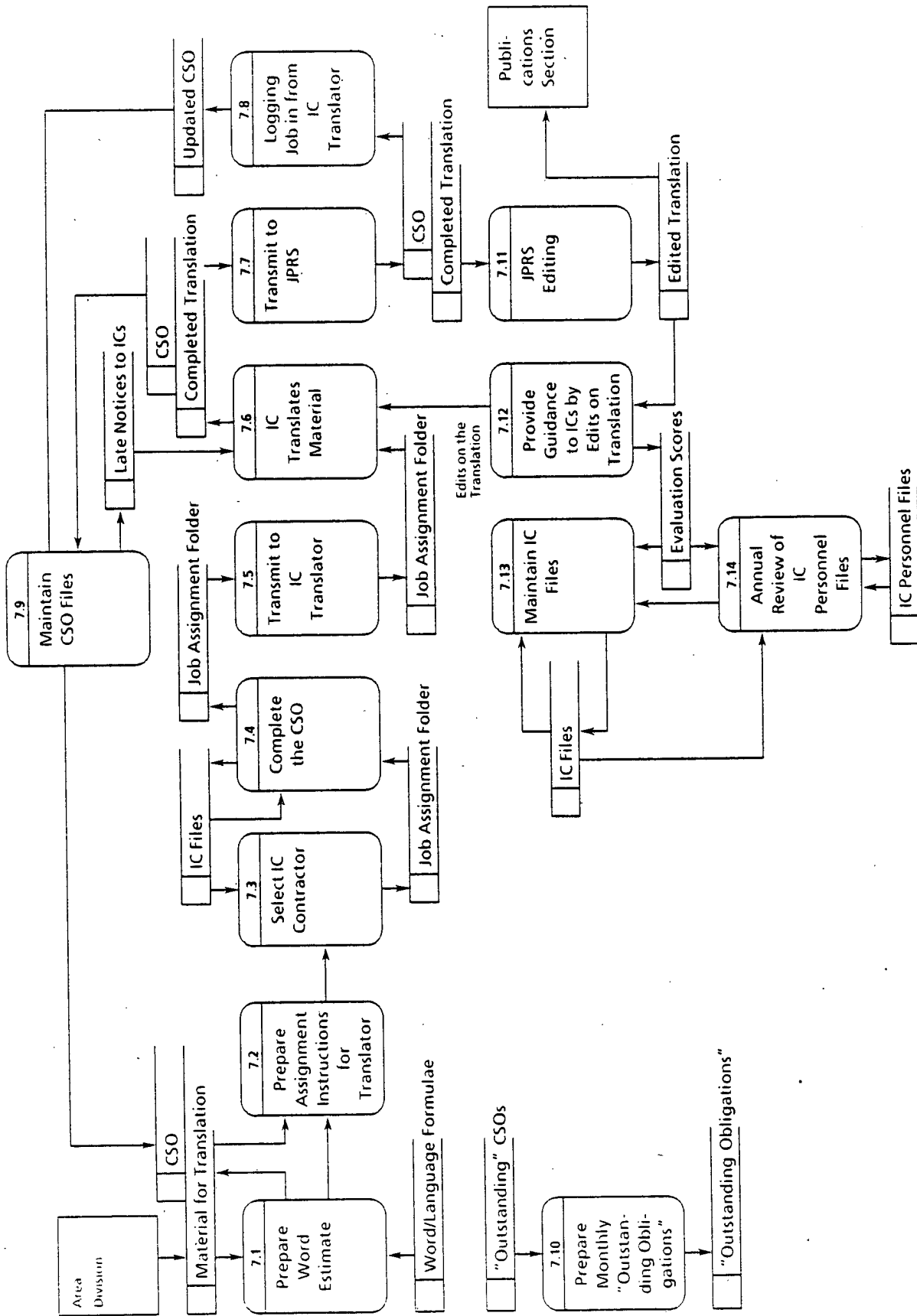

Figure 4-7. Joint Publications Research Service Data Flow Diagram--Area Section

XEROX

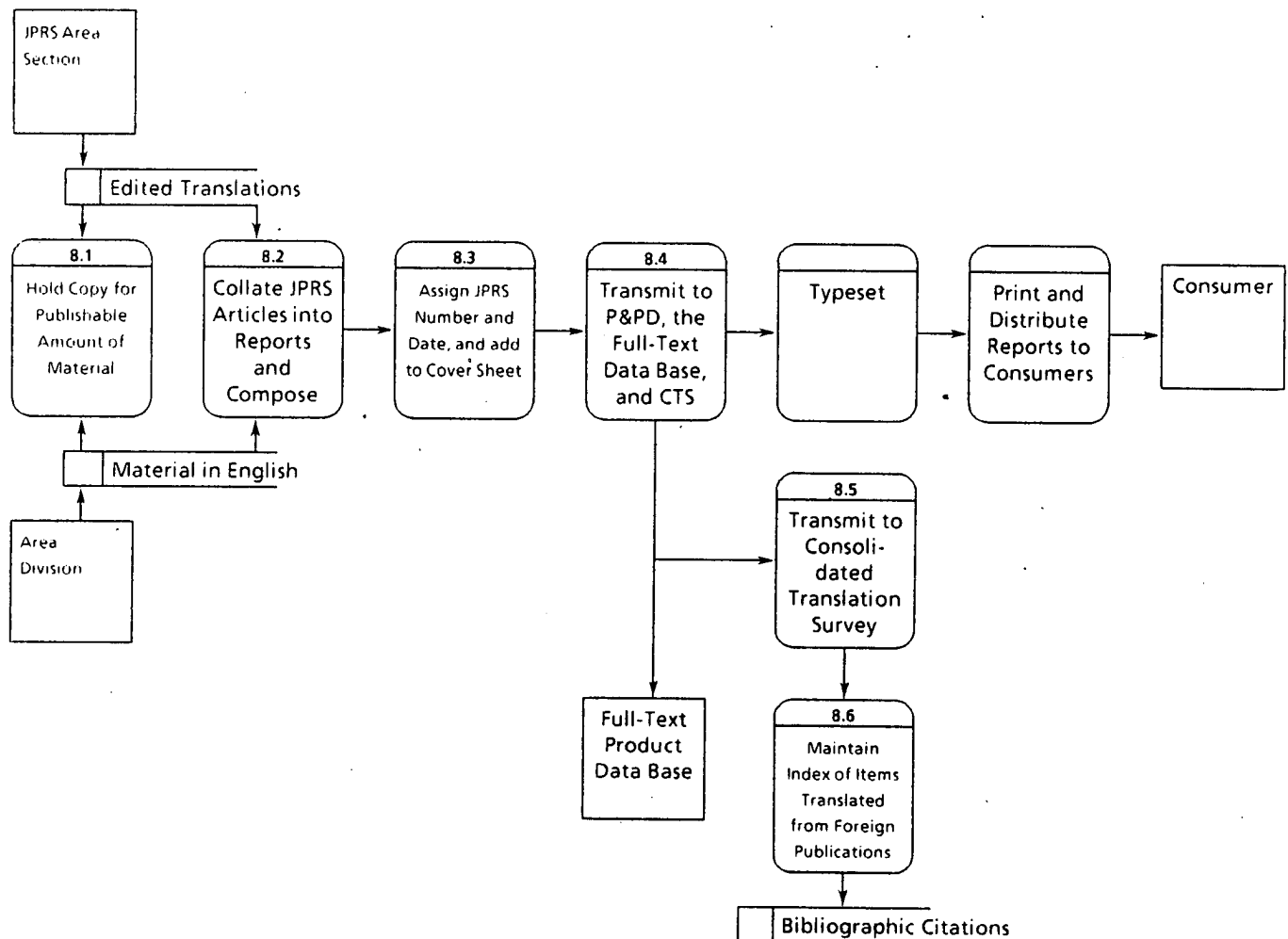

Figure 4-8. Joint Publications Research Service Data Flow Diagram--Publications Section, etc.

full-text product database from workstations on the Classified system. Individual analysts receive unclassified messages on their workstations on the Classified system via a one-way flow from the Unclassified system. Individual analysts send unclassified messages (e.g. queries to the Field) using shared workstations on the Unclassified system. Individual analysts send and receive classified messages using their workstations on the Classified system.

The Research Staff processes the incoming material in a much more structured manner than the individual Analysts do, dividing the material up into various categories, such as Authoritative Statements, or Important Commentaries, and filing excerpts of the items in one or more of the

shared Office Files. These files are maintained on the DBMS, and contain pointers to the Full-Text Product Database, to facilitate later searches. A major activity of the Research Staff is searching through existing material in the Analysis Group's various files to locate needed information on past activity and collected information. All Office Files maintained by the Research Staff are unclassified. Research staff review material, create custom indices, and run queries on the full-text product database from workstations on the Unclassified system. Where information is to be used on the Classified system it is transmitted in the form of a message via the one-way Mail Gateway.

XEROX

Research may take the form of a specific activity in response to an internal or external query, or take the form of the on-going analysis performed by each of the analysts in his assigned area of coverage. The Full-Text Product Database, along with the Office Files pointing to it, form integral parts of these analyses. Analyses are guided by the analyst's personal files on the database and knowledge of the intelligence community requirements, as well as by specific requests received through the Liaison and Requirements Branch. Results of analyses are published as weekly Trends, or as Analysis reports where extensive research is required. Individual analysts create and edit reports on their workstations on the Classified system. In all cases, analysis takes place in consultation with the field bureaus. Consultation with the Field takes place using shared Unclassified workstations, with the responses reaching the Classified system by means of the one-way Mail Gateway.

Analysts produce draft reports, based on the results of their research. Although an analyst's understanding of the trends and subject matter is enhanced by the classified material he receives, no classified information is incorporated into the reports he produces. (However, the Reports themselves, as well as Trends, may be classified to protect the conclusions which are drawn. Queries placed against the full-text product database may similarly be classified, although the material being queried is itself unclassified. For this reason, there must be a copy of the full-text product database accessible from the Classified system.) More (Unclassified) consultation with the field bureaus may take place during the production of a draft report. Completed draft reports are reviewed by an editor, along with the analyst's superiors. Revisions are made by the analysts, and again reviewed, before the report becomes final. In the course of editing, a spelling check is performed on the workstation, and syntax checking, etc., is performed using a

network service running Writer's Workbench™ in batch mode. Final versions of the sections in a report are placed in a file folder, ready for composition of the report.

Composition for each report takes place in batch/background mode, using the contents of each section in the folder in turn. During composition, a list of recalcitrant pages which do not fit the page design criteria is produced. These problem pages can then be adjusted interactively; re-composition, if necessary, starts from the point of the problem, leaving earlier pages untouched. When the composition pass is complete, and all corrections have been made, Tables of Contents and Indexes are produced. Final edited and composed reports are deposited in the full-text product database, along with the TOCs and Indexes.

For typesetting, the folder containing a finished composed report with its front and back matter is moved to the "Typesetter Service", where composed reports are automatically converted to phototypesetter format and delivered to the phototypesetter electronically. Since this process takes place using a network service, the phototypesetter composition codes are never present in the document(s) on the workstation, and do not have to be explicitly entered by anyone.

Completed reports are sanitized, and manually transferred to the Unclassified system for delivery to the full-text product database and the Wire Service for transmission to the Field Bureaus, as well as to Lateral Consumers and Wire Service Consumers.

4.11 Liaison and Requirements Branch

The Liaison and Requirements Branch (L&RB) serves as the interface between the operational groups of FBIS and their customers in the Intelligence Community and the rest of the U.S. Government. L&RB uses the Unclassified system for maintaining and distributing the Lateral

Process Flows

XEROX

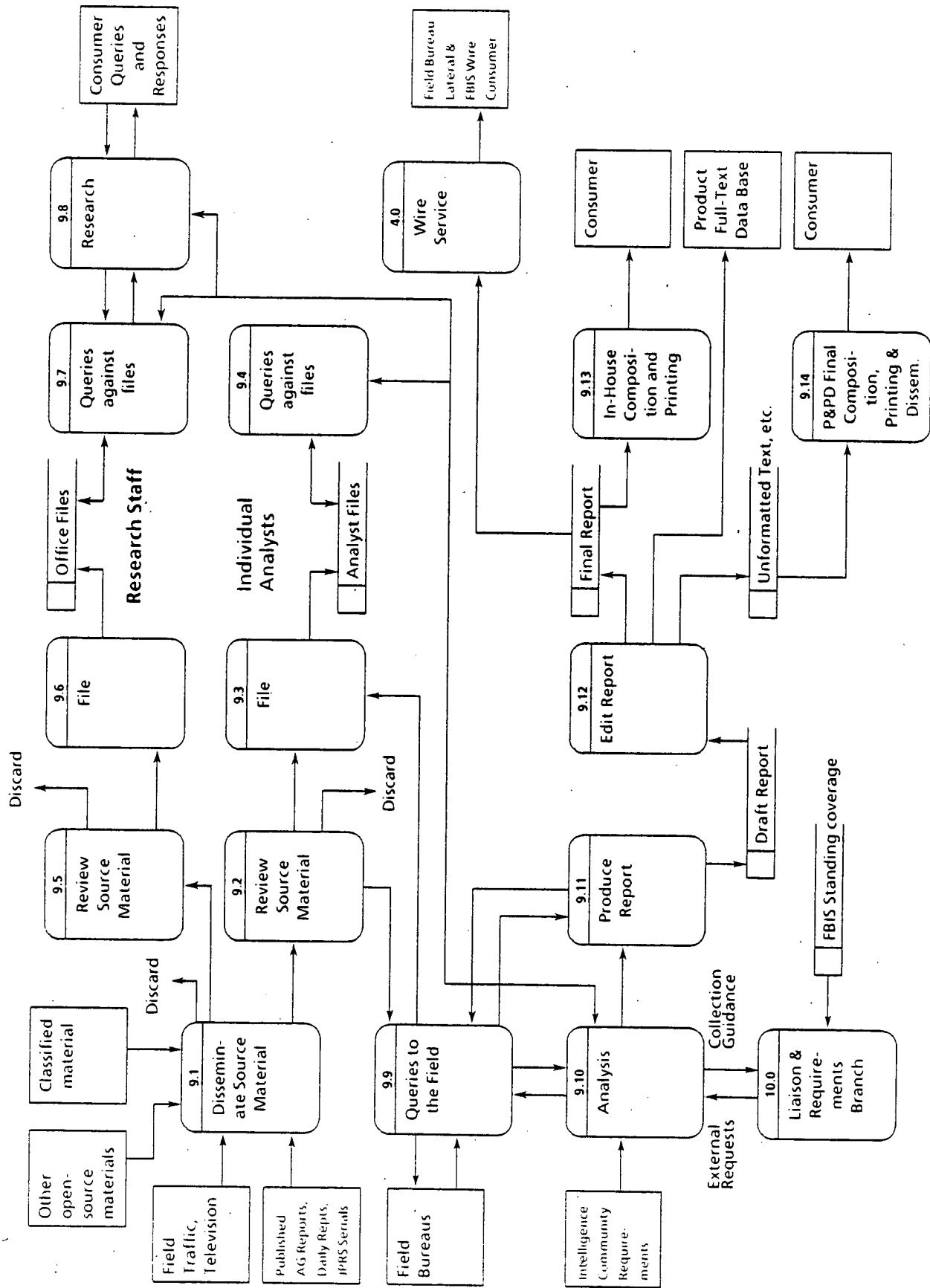

Figure 4-9, Analysis Group Data Flow Diagram

XEROX

Services List, which determines the distribution of publishable messages on the FBIS Wire and from the Field Bureaus, and the Distribution List, which determines dissemination of the printed products of FBIS, when they are completed. The Lateral Services List is distributed to the Field in electronic form.

L&RB also evaluates the community needs, and controls the Collection and Processing Requirements which are levied on the operating groups of FBIS. Changes in collection requirements can extend to such matters as setting up a new serial title for JPRS. The Collection and Processing Requirements are produced, maintained, and disseminated using the Classified system. L&RB produces reports, as directed, to FBIS and higher levels of management.

4.12 REFERENCE SERVICE

The Reference Service maintains the lists of Cabinet and Diplomatic officers of the countries of the world, which are used by every Bureau to verify the spellings of the names of these people, when they appear in their translations. These lists are maintained and distributed electronically to the Field using the Unclassified system. The Reference Service also provides items such as books and maps to individual Bureaus on request; Reference Service records for these transactions, and for general subscription information, are kept on the DBMS and processed using the Unclassified system.

The Reference Service is responsible for the reception and dissemination of classified cables, using the Classified system, to the various groups at FBIS Headquarters, when the cables arrive with only general address information. Cables addressed to individuals will be delivered directly to that individual's mailbox on the Classified system

4.13 HEADQUARTERS COLLECTION SUPPORT

Headquarters collection support is provided by the Monitoring Operations Division (MOD) of Operations Group. This group provides the clearinghouse for all broadcast coverage data developed by the cruising activities of the Field Bureaus, producing a worldwide list of broadcasting, press agency, and publications activity. This is then combined with the coverage requirements developed at headquarters to produce the Coverage Schedule, showing the specific coverage responsibilities of each Bureau. This schedule is maintained on the DBMS. MOD also provides technical assistance regarding collection activities at the Bureaus. Exchange of information with the Field takes place using the Unclassified system and the normal message traffic.