

**PROGRAM BUILD PLAN (PBP)
FOR THE
FBIS MODERNIZATION PROGRAM**

CONTRACT NO. 84X*927700*000

03 JANUARY 1985

**ESL INCORPORATED
A SUBSIDIARY OF TRW
SUNNYVALE, CALIFORNIA**

**PROGRAM BUILD PLAN (PBP)
FOR THE
FBIS MODERNIZATION PROGRAM**

CONTRACT NO. 84X*927700*000

03 JANUARY 1985

**ESL INCORPORATED
A SUBSIDIARY OF TRW
SUNNYVALE, CALIFORNIA**

Table of Contents

1.0	INTRODUCTION	1
1.1	Purpose	1
1.2	Design Summary	1
2.0	MODULAR IMPLEMENTATION APPROACH	4
2.1	Implementation Interdependencies	6
2.2	Design Building Blocks	9
2.2.1	Information Processing Subsystem	9
2.2.1.1	Phase I	9
2.2.2	Daily Operations Subsystem	11
2.2.2.1	Phase I	11
2.2.2.2	Phase II	11
2.2.3	Translation Services Subsystem	13
2.2.3.1	Phase I	13
2.2.3.2	Phase II	13
2.2.4	Analytical Services Subsystem	15
2.2.4.1	Phase I	15
2.2.4.2	Phase II	15
2.2.4.3	Phase III	15
2.2.4.4	Phase IV	16
2.2.5	Multi-Lingual Capability	18
2.3	Phased Operational Modes	18
2.3.1	Phase I	18
2.3.2	Phase II	19
2.3.3	Phase III	19
2.3.4	Phase IV	19
3.0	FBIS PROGRAM PLAN	20
3.1	CRITICAL DEVELOPMENT AREAS	20
3.2	Summary of Program Activities	22
3.3	FMS Program Activities	24
4.0	PROGRAM DEVELOPMENT PLAN	34
APPENDIX A	MODIFIED BUREAU DESIGN DESCRIPTION	
APPENDIX B	MODIFIED HEADQUARTERS DESIGN DESCRIPTION	

List of Figures

1. Figure 1-1: FMS Subsystems
2. Figure 2-1: Building Block Implementation Interdependencies
3. Figure 2-2: IP Subsystem Phased Design
4. Figure 2-3: DO Subsystem Phased Design
5. Figure 2-4: TS Subsystem Phased Design
6. Figure 2-5: AS Subsystem Phased Design
7. Figure 3-1: FMS Summary Program Schedule
8. Figure 3-2a: FMS Program Inter-Relationships
9. Figure 3-2b: FMS Program Inter-Relationships
10. Figure 3-2c: FMS Program Inter-Relationships
11. Figure 3-3a: FMS Detailed Program Schedule
12. Figure 3-3b: FMS Detailed Program Schedule
13. Figure 3-3c: FMS Detailed Program Schedule
14. Figure 4-1a: FMS Development Schedule
15. Figure 4-1b: FMS Development Schedule
16. Figure 4-1c: FMS Development Schedule

1.0 INTRODUCTION

The FBIS Modernization System (FMS) comprises the computer-assisted text processing, archive, retrieval, and management system that satisfies the modernization requirements stated by FBIS.

1.1 Purpose

This document describes the plan to design, implement, and deliver the FMS. The description includes discussions of the functional phasing, program and development schedules, and program interdependencies.

1.2 Design Summary

The subsystems in the ESL design for the FMS have not changed since the last briefing, except that the Collection Subsystem at the bureaus has been deleted in response to requirements changes. The FMS consists of four subsystems, one for the bureaus and three at FBIS headquarters. Each subsystem is designed to support a particular user community: the staff at the bureaus; the Daily Report production staff; the JPRS Reports staff; and the Analysis Group and related Production Group staff.

Each subsystem shares some functions with the other subsystems; each also supports functions specifically for its own user community.

Figure 1-1 summarizes these subsystems with the functions associated with each. This figure also shows the primary communication paths between the subsystems. The heavy-drawn arrows indicate electronic links, with a one-way-only link from

Daily Operations to Analytical Services across the boundary from the unclassified side of FBIS headquarters to the classified side. The lightly-drawn arrow indicates a hardcopy (i.e., printed output) link, with appropriate security reviews, from the classified side to the unclassified side.

Program Build Plan (PBP)

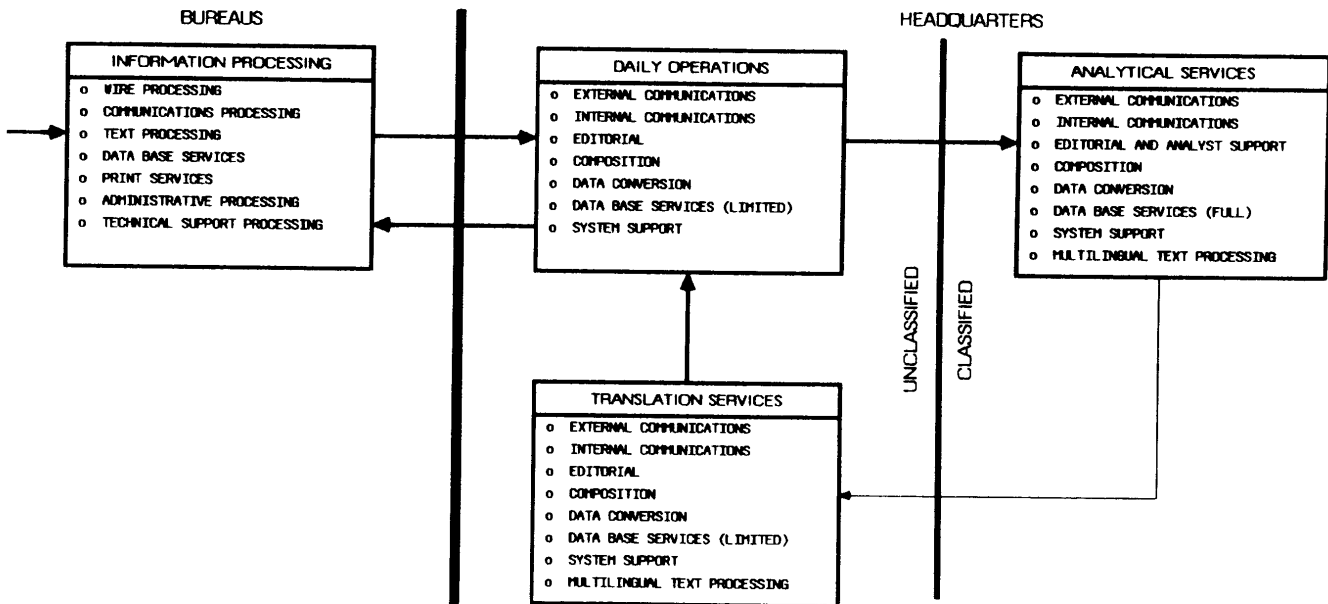

Figure 1-1. FMS Subsystems

2.0 MODULAR IMPLEMENTATION APPROACH

The ESL approach to the FMS design and implementation employs top-down system engineering simultaneously with bottom-up evaluations and prototyping of key components.

Top-down systems engineering includes the detailed analysis of system requirements, the generation of appropriate system specifications, and results in system and subsystem designs.

The bottom-up evaluations include the detailed survey and evaluation of existing, off-the-shelf hardware and software products, and prototyping of the man-machine interface and critical hardware and software components. This process defines the realm of possible solutions that satisfy the system specifications resulting from the systems engineering.

After the best solution has been selected, system engineering continues to develop the plan to build the system in a low-risk manner. This process has led to the partitioning of the FMS implementation into four subsystems and up to four phases for each subsystem.

Each of the four subsystems that comprise the FMS design can be built separately; this structure provides the first level of modularity to the FMS implementation approach. Each subsystem, by itself, can provide significant improvements to the FBIS production operation.

To provide additional program modularity, subsystems can be built in multiple phases. A phased build of each subsystem consists of implementing and installing partial subsystem capabilities that cumulatively provide increasing amounts of functionality to FBIS personnel. One such implementation phase

was chosen for the bureau subsystem; two for the Daily Operations Subsystem; two for the Translation Support Subsystem; and four for the Analytical Support Subsystem. Furthermore, the multilingual capability was defined as a separate building block. The total number of design building blocks (ten) is thus the sum of the number of implementation phases for the four subsystems.

The choice of the development phases was driven by the desire to expedite the early availability of those functional capabilities that are predominantly commercial procurements. The phasing was also driven by the need to schedule build phases according to functional dependencies and the desire to minimize risks. The first development phase for the Headquarters subsystems thus consists primarily of off-the-shelf hardware and software, configured to suit the FBIS operation, with a minimum of integration and software development required.

The building blocks were also selected so as to separate the simple implementation activities from the more difficult ones. The second set of phases thus includes the remaining development activities, except for the product data base capabilities, which are left to the third phase. A fourth phase was chosen to provide the purchase of additional hardware needed to accommodate growth of the product data base.

Building block choices were made to permit the scheduling flexibility to incur costs when desired, or to incur costs uniformly over the life of the program. In the case of the bureau subsystem, it is possible to achieve this goal by developing it in a single phase, then spreading out the installation of the field bureaus over a period of time. (The alternative bureau development approach is a multi-phase development and installation, which is significantly more expensive because of the recurring overseas travel costs for installation and training).

A significant part of the plan is the use of a test bed to support performance analysis, subsystem and software design, product evaluation, and prototyping activities. The test bed is established early and maintained throughout the program. It is a key ingredient in the bottoms-up engineering analysis, allowing designers to evaluate products before committing to full procurement. The test bed also provides an environment for architecture simulations and user interface prototyping. Some portions of the test bed will evolve to support implementation and test of the subsystems. The test bed will be used to provide continuity of a development environment between acquisitions of equipment that are delivered to FBIS.

The multilingual capability was selected as a separate building block because of its inherently off-the-shelf and stand-alone nature.

The set of building blocks described in the succeeding sections satisfy the criteria described above, and also addresses FBIS modernization priorities as ESL understands them at this time. There are alternative methods of defining these blocks such that other sets of priorities can be accommodated -- ESL is quite willing to discuss such alternatives with FBIS.

2.1 Implementation Interdependencies

Figure 2-1 details the subsystem-phase building blocks for FMS. Each building block shows the functions involved, and the hardware to be acquired to support those functions.

The arrows in Figure 2-1 indicate dependencies among the various building blocks. These arrows do not indicate that one building block must be completed prior to beginning the next building block; they do indicate that an activity within one

Program Build Plan (PBP)

block must complete prior to the initiation of the corresponding activity within the next block. For example, the initiation of installation during Phase II is predicated on the completion of the Phase I installation.

Program Build Plan (PBP)

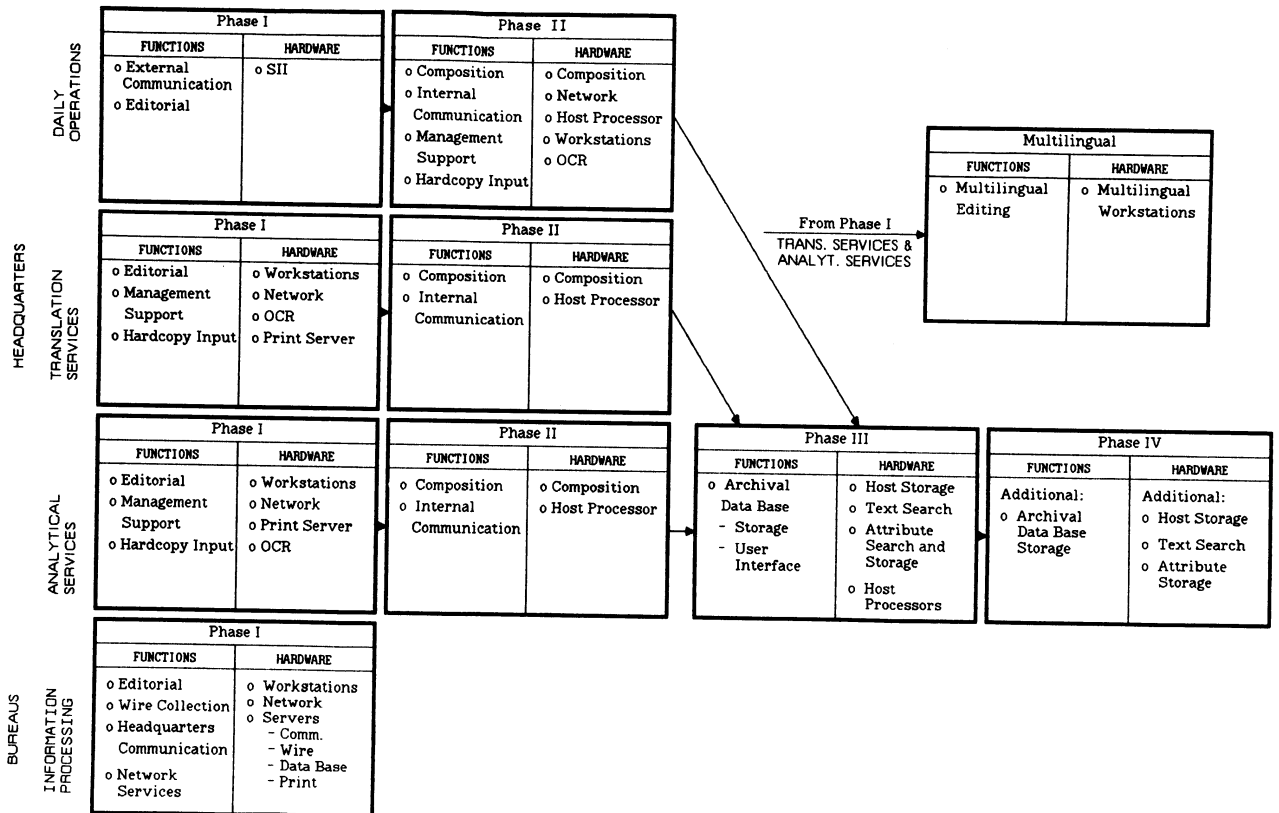

Figure 2-1. Building Block Implementation Interdependencies

2.2 Design Building Blocks

The following sections describe the phased building of each of the four FBIS design subsystems. This document does not attempt to fully explain the ESL design, just the plan to build the design. For full details on the design itself, please refer to earlier documentation.

2.2.1 Information Processing Subsystem

2.2.1.1 Phase I

The subsystem to be installed at each bureau is not envisioned as a phased development. The design is simple enough not to require a phased build and installation for the purpose of reducing risk. Furthermore, a phased installation would significantly add to the program costs because the installation and training costs (with their corresponding travel) would nearly be doubled. It is far simpler to spread out acquisition costs by spreading out the recurring costs -- that is, by spreading out the installations. The non-recurring costs are small enough that a phased development would not significantly affect the government's spending profile.

While not practical for financial reasons, it is possible to define several different versions of a phased bureau development in order to provide early delivery of certain functions. ESL chose not to split the bureau development effort to attempt this goal because FBIS indicated its desire to postpone the bureau development for a year or more, which is contrary to a motivation for early deliveries.

Program Build Plan (PBP)

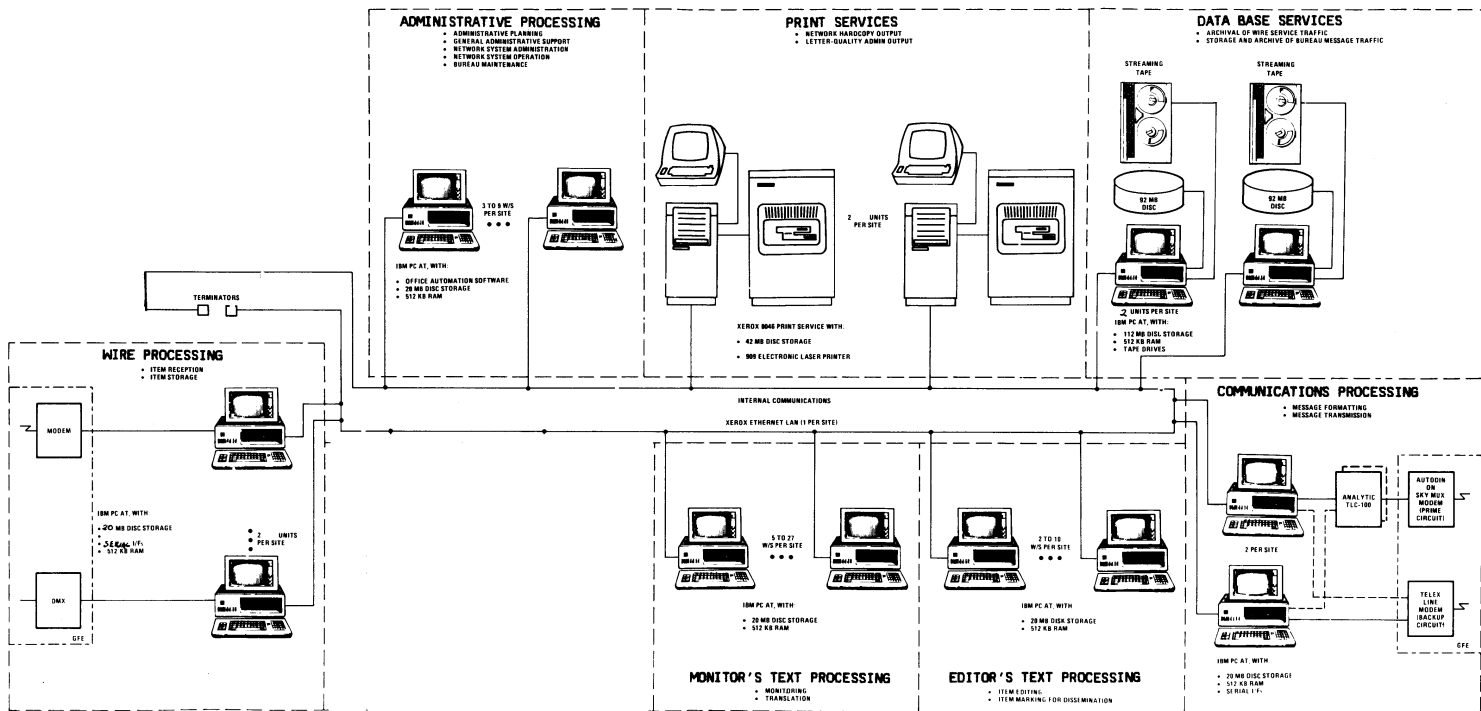

Figure 2-2. IP Subsystem Phased Design

2.2.2 Daily Operations Subsystem

2.2.2.1 Phase I

Phase I of the Daily Operations subsystem provides the high-volume, sophisticated softcopy editing capability required to support production of the Daily Reports.

Phase I also provides the interfaces to the bureaus (via Autodin) and the wire services. The FMS supports these interfaces on a 24-hours-a-day, 7-days-a-week basis through the non-stop computer system that is the basis of the editorial system.

2.2.2.2 Phase II

Phase II adds the network of personal workstations, a host processor with disk storage, print servers, and composition stations.

The workstations add the capability of management support and optical character recognition (OCR) input of hardcopy text data. The host processor provides communication between the editorial system, the Daily Operations network, and the host processors within the Translation Services and Analytical Services subsystems. The composition stations and print servers provide the high-quality final output capability.

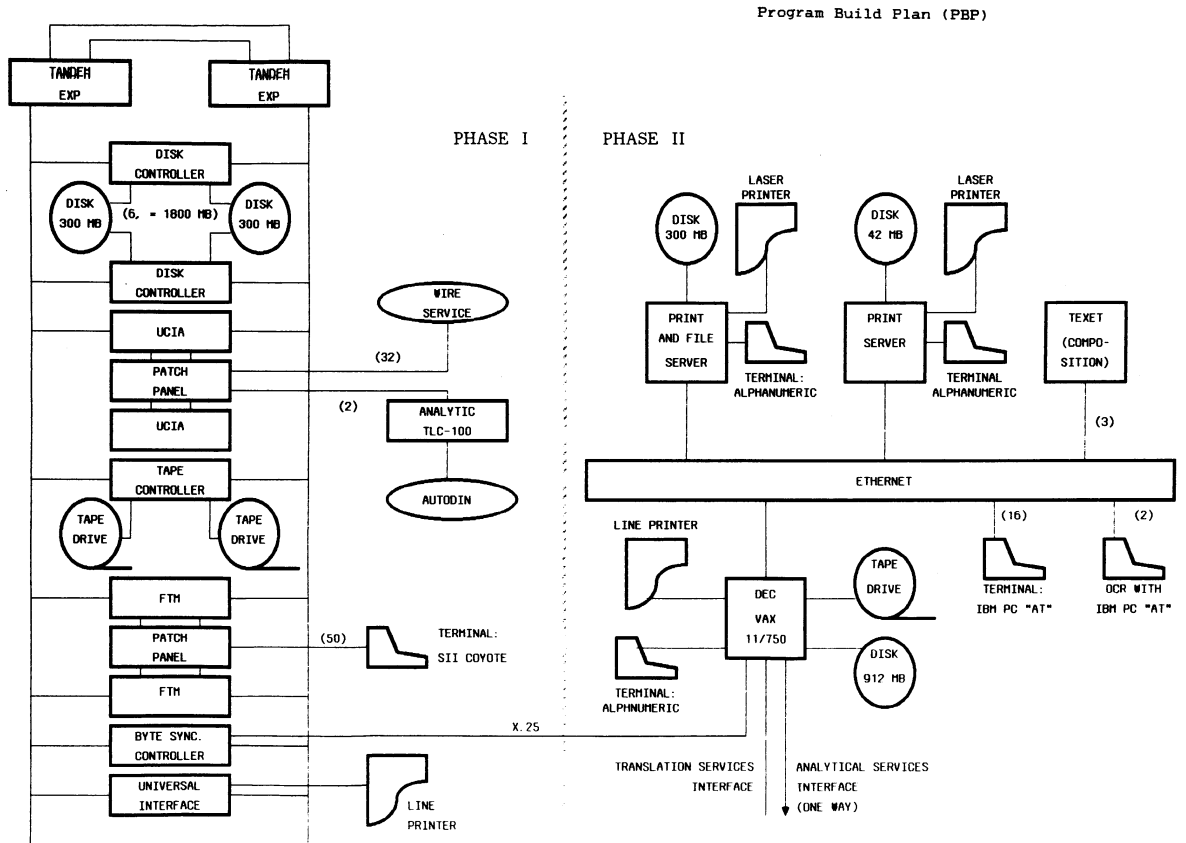

Figure 2-3. DO Subsystem Phased Design

2.2.3 Translation Services Subsystem

2.2.3.1 Phase I

Phase I of the Translation Services subsystem provides a network of personal workstations to support the editorial and management support capabilities required to support the production of JPRS reports.

This network includes workstations with editorial and management support software, workstations to support the OCR of hardcopy input, and print servers for final output.

2.2.3.2 Phase II

Phase II adds to the network composition stations and a host processor, in a similiar fashion as Phase II of the Daily Operations subsystem does. The host processor provides a central facility for file storage, and communications to the Daily Operations subsystem host processor.

Program Build Plan (PBP)

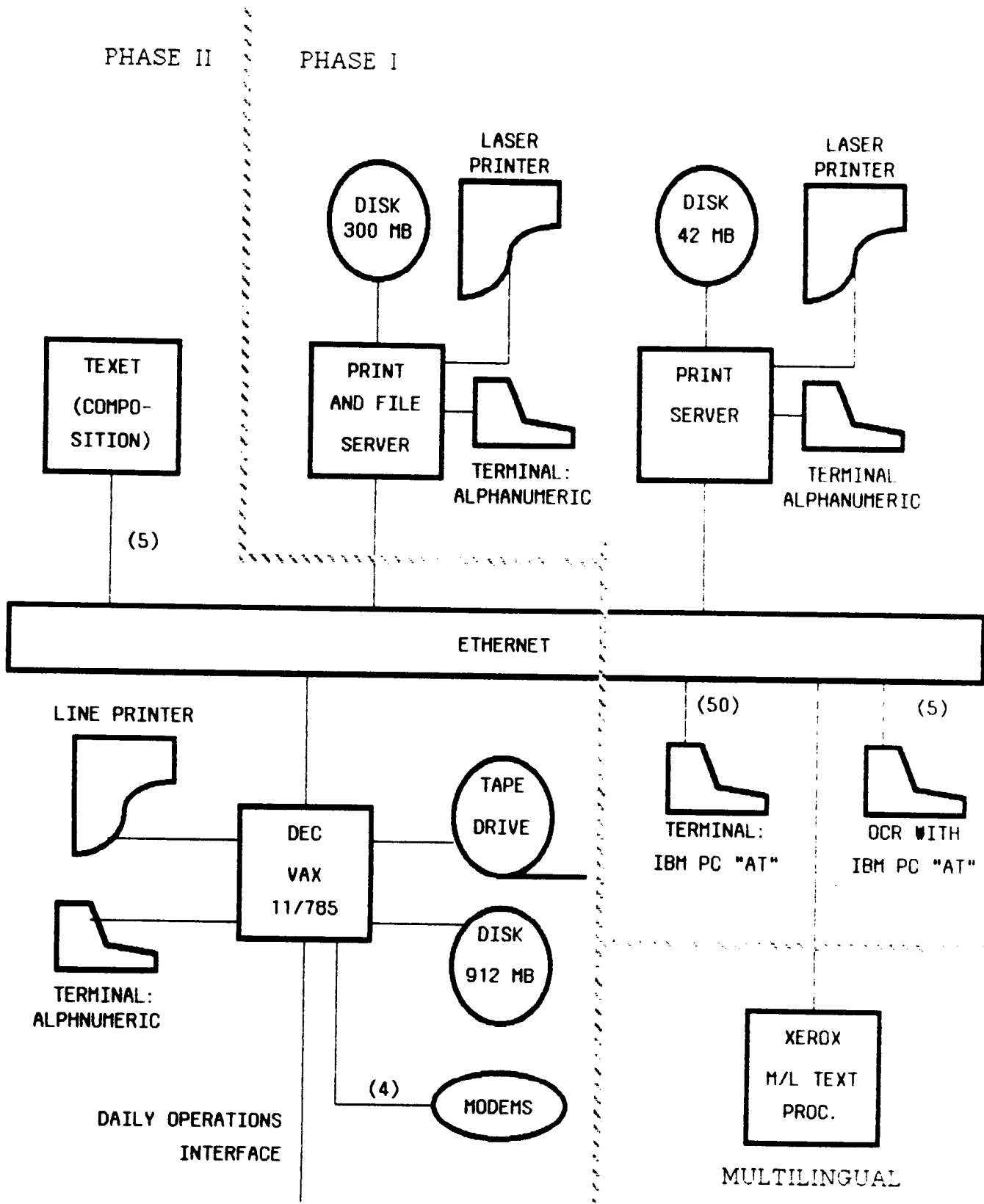

Figure 2-4. TS Subsystem Phased Design

2.2.4 Analytical Services Subsystem

2.2.4.1 Phase I

Phase I of the Analytical Services subsystem is similar to Phase I for Translation Services. This phase provides a network of personal workstations to support the editorial and management support capabilities required to support the production of analysis and other reports.

This network includes workstations with editorial and management support software, workstations to support the OCR of hardcopy input, and print servers for final output.

2.2.4.2 Phase II

Phase II is similar to Phase II for the Translation Services subsystem. This phase adds to the network composition stations and a host processor. The host processor provides a central facility for file storage, and communications to the Daily Operations subsystem host processor.

Phase II for Analytical Services includes a hardware configuration different from that for Translation Services, in support of future additions in Phase III.

2.2.4.3 Phase III

Phase III adds the archival data base storage and search capability to the Analytical Services subsystem at FBIS headquarters.

Phase III adds a second network, additional host

processors, an attribute data base processor, text search processors, and a large amount of disk storage for the host processors.

The attribute and text search processors provide the capabilities required to support the organization, search, and retrieval of documents from the archival data base. The additional host processor disk storage enables the subsystem to store the original source text of the archival data base.

The additional host processors provide efficient access for many users to the original source text in the archival data base. In addition, these processors provide efficient translation of user requests to the attribute and text search processors.

2.2.4.4 Phase IV

Phase IV adds host processor disk storage and text search processors, to handle the anticipated growth in the archival data base.

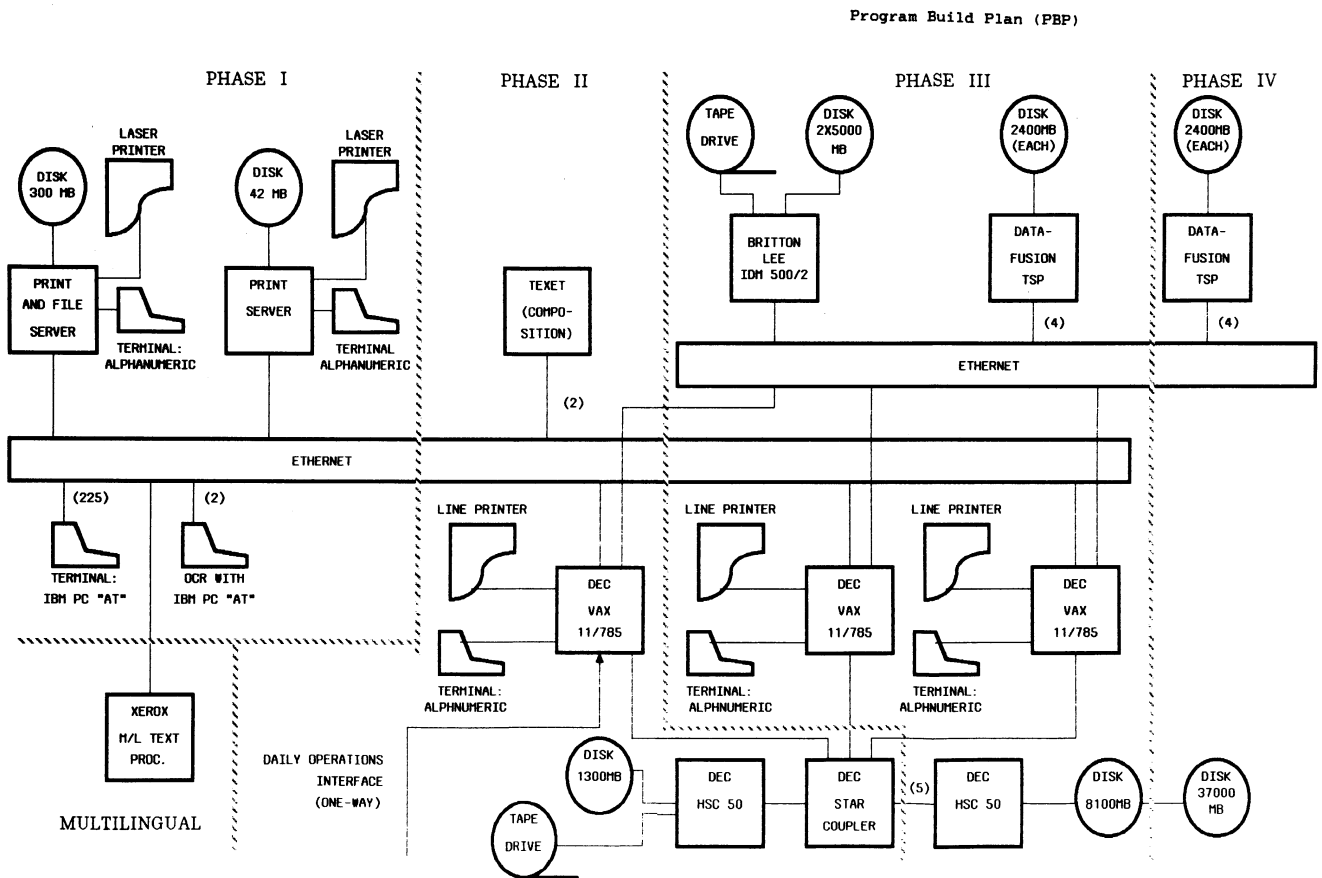

Figure 2-5. AS Subsystem Phased Design

2.2.5 Multi-Lingual Capability

The Multilingual phase adds multilingual text processors to each network, to support the multilingual text processing requirements.

2.3 Phased Operational Modes

As noted above, there are several common capabilities in Phase I and Phase II between the headquarters subsystems. It makes good sense to develop these capabilities in common. While it is possible to develop each subsystem on its own particular schedule, it is desirable to describe the headquarters subsystems in parallel such that all Phase I activities conclude at about the same time, and similarly for Phase II, Phase III, and multilingual developments, in order that they be more easily understood. This section summarizes the developments of the subsystems assuming they do occur in parallel. (Bureau development occurs on a totally independent schedule.)

2.3.1 Phase I

Phase I enables all FBIS staff members to convert from hardcopy to softcopy input, edit, and production of translations, reports, and analysis results. Once a document is entered in softcopy, it need never be rekeyed as part of an editing step -- all editing becomes a process of changing existing softcopy. Documents originally existing in softcopy from the field bureaus or from the wire services are maintained in softcopy at headquarters, eliminating any full rekeying of such items.

Phase I for Translation and Analytical Services also provides the management support capabilities offered by an

integrated personal workstation spreadsheet-and-data-base software packages.

2.3.2 Phase II

Phase II provides local central storage for each subsystem at headquarters, and the communication paths between each of these subsystems. It also completes the transition to full softcopy preparation of documents by adding the composition equipment, which provides the softcopy page makeup capability.

2.3.3 Phase III

Phase III adds the product data base storage, retrieval, and search capabilities of the Analytical Services subsystem.

2.3.4 Phase IV

Phase IV is simply an extension of Phase III: additional hardware is purchased and installed on the Analytical Services subsystem to accomodate the growing size of the product data base.

3.0 FBIS PROGRAM PLAN

3.1 CRITICAL DEVELOPMENT AREAS

The FBIS modernization effort includes three critical development areas: the data base services portion of the Analytical Services subsystem; the integration of commercial equipment throughout the system; and the transition to full FMS operation.

The approach to minimizing the risk involved in the data base services development includes:

- o Building on a base of established commercial equipment, including the host, attribute data base, and text search processors, that does not push the state-of-the-art of data base management systems;
- o Performance analysis and simulation to support tradeoffs among cost, risk, and performance;
- o Prototyping critical components, such as the attribute and text search processors, to validate functionality vs. requirements and simulation results, and to evaluate critical parameters;
- o Early prototyping of the user interface, to validate top-down derived requirements, to refine operator interface requirements, and to define user scenarios for simulation;
- o Integration and installation (in Phase III) into the integrated and established host-and-network subsystem (from Phase II) as a low-risk incremental capability.

The FMS involves a significant level of integration of commercial equipment, because no single off-the-shelf products satisfy FBIS requirements, and the vendor products do not generally interface with each other. The approach to minimizing the risk in this integration includes:

- o Vendor evaluation within the test bed, to reconcile requirements vs. capabilities, and identify alternative methods to satisfy the requirements with existing capabilities;
- o A system design that emphasizes loosely-coupled interfaces between vendor-provided products;
- o Phased implementation;
- o Commonality among the designs of the headquarters subsystems.

The transition to the operation FMS system involves some risk in maintaining production quality and throughput during the transition process. This risk is minimized by:

- o Phased implementation of FMS capabilities;
- o Extensive training courses, including early training of key people prior to system delivery.
- o Prototyping of critical human interface software to ensure user acceptance and ease of use.

3.2 Summary of Program Activities

Each phase for each subsystem follows a standard procedure of design, implementation and test, installation, and operational transition stages. Differences do occur in the amount of effort required for each activity within each phase. For instance, a single design review is used for Phase I and Phase II design (rather than a PDR and a CDR cycle), as the amount of development is so small and so well defined (vendor and data file integration) to not require a preliminary review.

Every design stage leads to a (final) design review. The design must be deemed satisfactory prior to the start of implementation and test.

The completion of most stages within Phase II depends on the prior completion of the corresponding stage within Phase I. The same is generally true for Phase III following Phase II.

However, the design stage of Phase III begins very early. The proper design of the archival data base portion of Analytical Services will require significantly more analysis and prototyping than any other portion of the FMS, and this is reflected in the schedule periods for Phase III design and implementation.

Figure 3-1 summarizes all of these stages for each phase for each subsystem (system level activities are not shown at this general summary level). The figure also shows the three alternative schedules for the modernization of the bureau subsystem, depending upon the three government-provided start dates for that subsystem.

3.3 FMS Program Activities

Figure 3-2 depicts the program activities for the FBIS modernization effort, their inter-relationships, and dependencies. (There are three versions of this figure, "a", "b", and "c", for the three different bureau subsystem start dates.)

Each box in the figure signifies an activity, or effort; the number in each box indicates the number of weeks needed for that effort. Each circle signifies a significant schedule milestone, particularly the customer design reviews. Each line between boxes and circles signifies that the effort or milestone to the right depends upon the effort or milestone to the left.

Figure 3-3 (three versions) depicts the detailed program schedule that corresponds to Figure 3-2.

Program Build Plan (PBP)

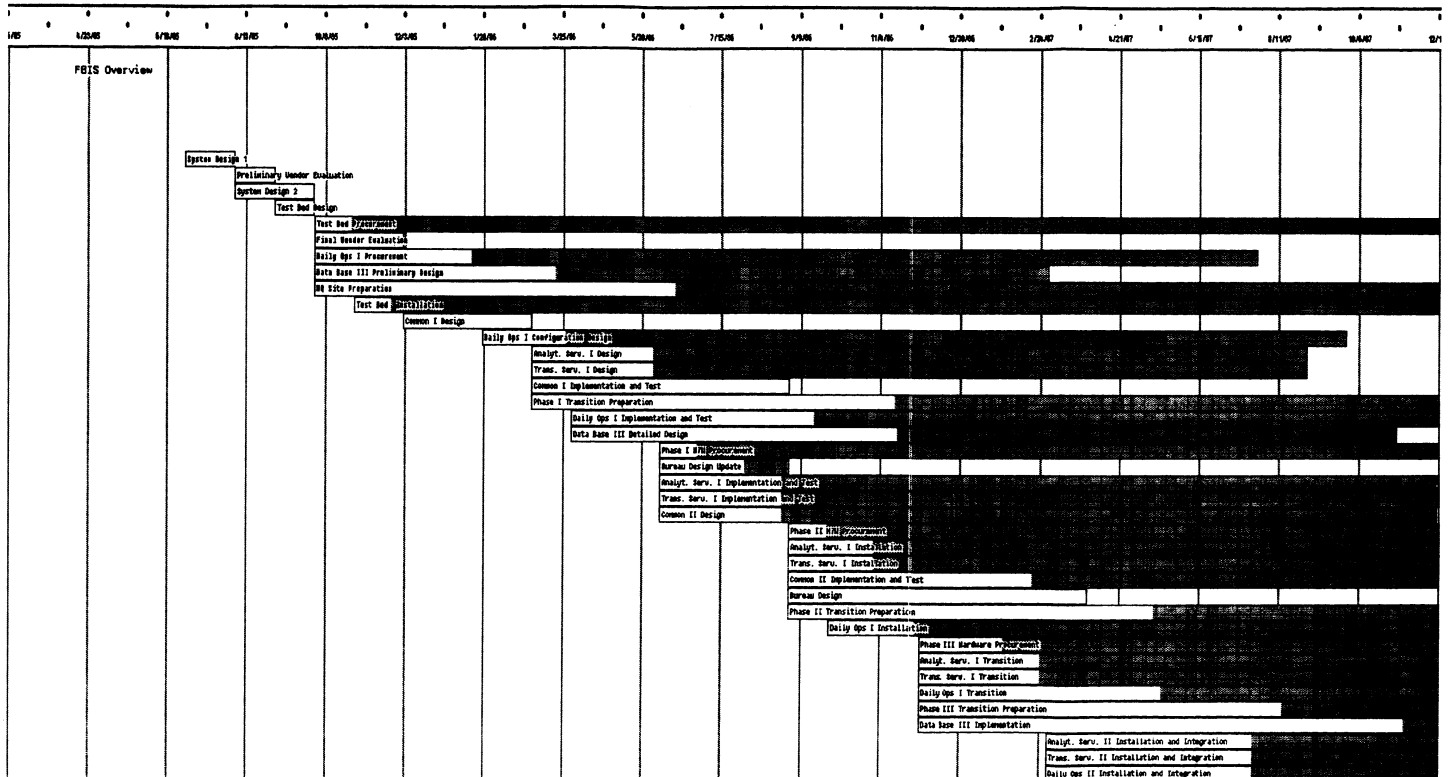

Figure 3-3a. FMS Detailed Program Schedule (Sheet 1 of 2)

Program Build Plan (PBP)

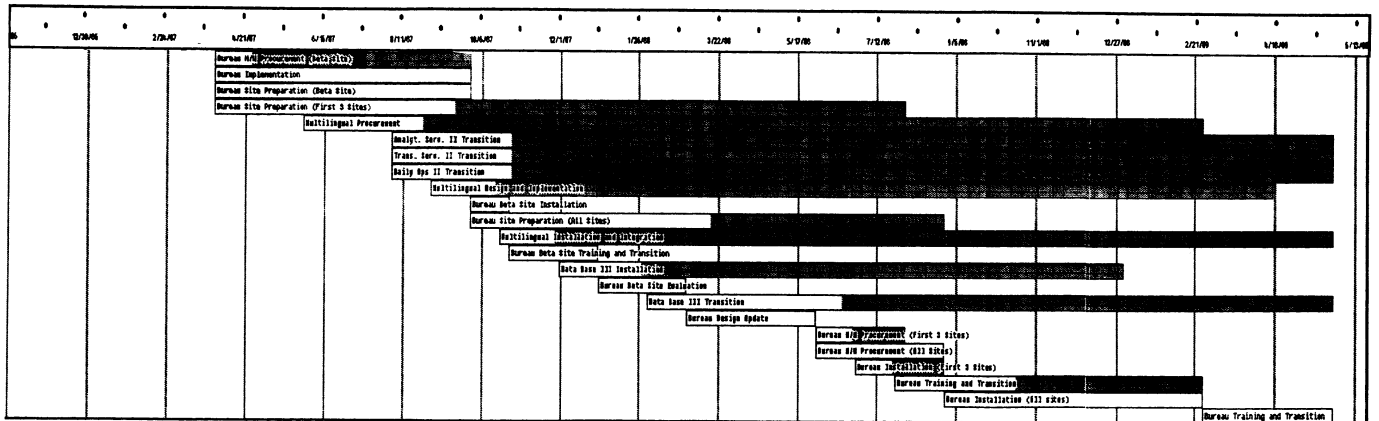

Figure 3-3a. FMS Detailed Program Schedule (Sheet 2 of 2)

Program Build Plan (PBP)

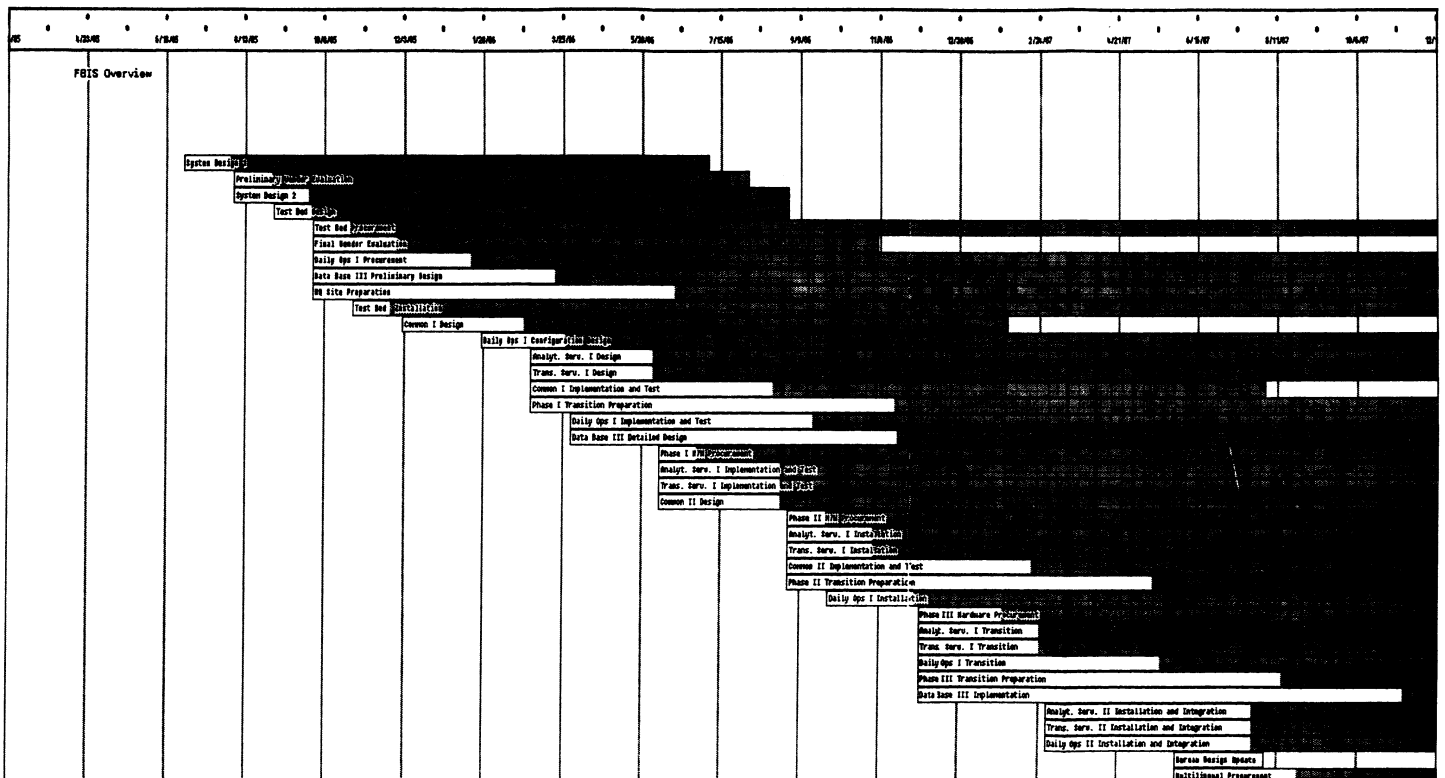

Figure 3-3b. FMS Detailed Program Schedule (Sheet 1 of 2)

Program Build Plan (PBP)

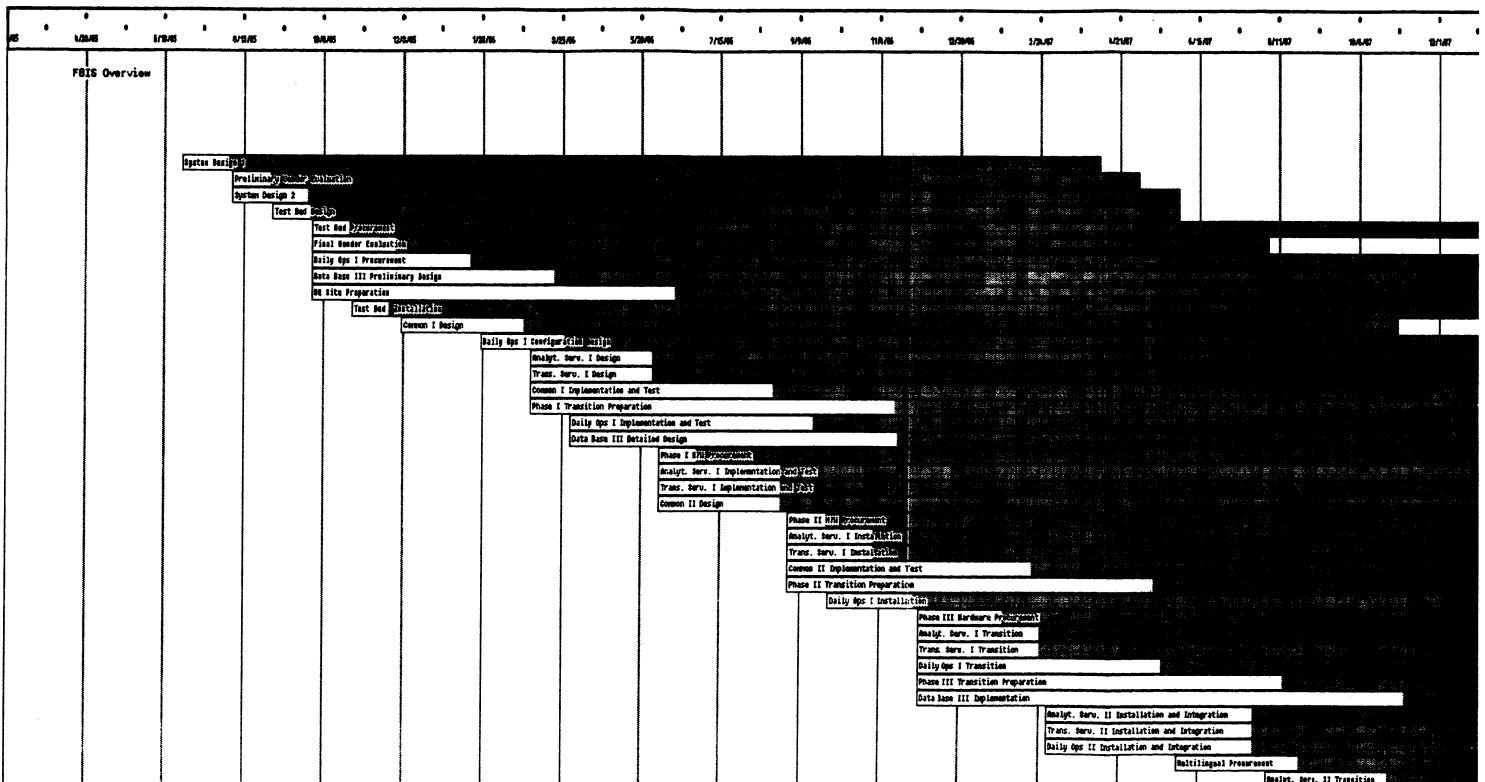

Figure 3-3c. FMS Detailed Program Schedule (Sheet 1 of 1)

Program Build Plan (PBP)

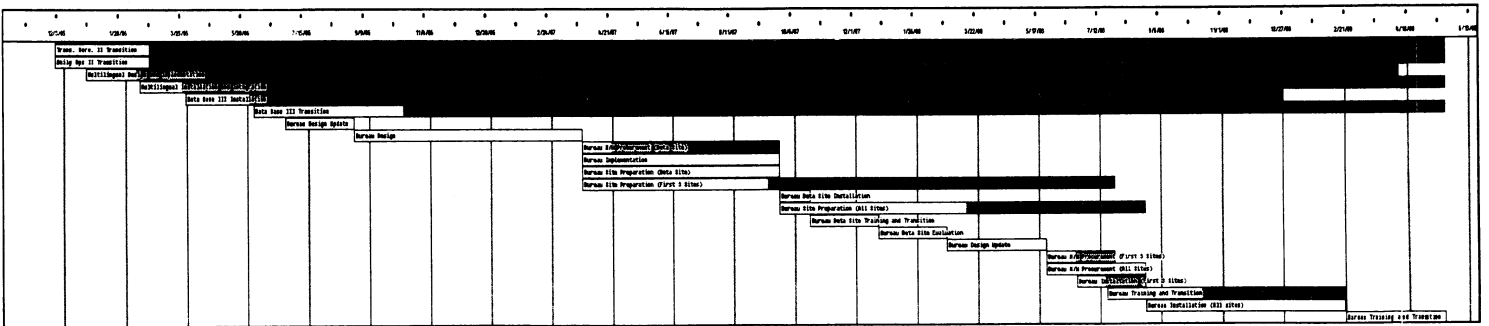

Figure 3-3c. FMS Detailed Program Schedule (Sheet 2 of 2)

4.0 PROGRAM DEVELOPMENT PLAN

Figure 4-1 depicts the development plan for the FBIS modernization effort. The three versions of this figure differ in the start date specified for the bureau subsystem development effort.

This schedule is different from the program schedule of Figure 3-3 in that it is organized by elements of the work breakdown structure. That is, the activities shown on Figure 3-2 (the activity network) have been mapped onto the WBS. (The mapping is not one-to-one -- it is both many-to-one and one-to-many.) Within each major WBS element, the primary schedule activities of that element are illustrated. (Only major WBS elements are shown, and just the key activities within that element are illustrated in order to simplify the schedule so it can be readily understood.)

Program Build Plan (PBP)

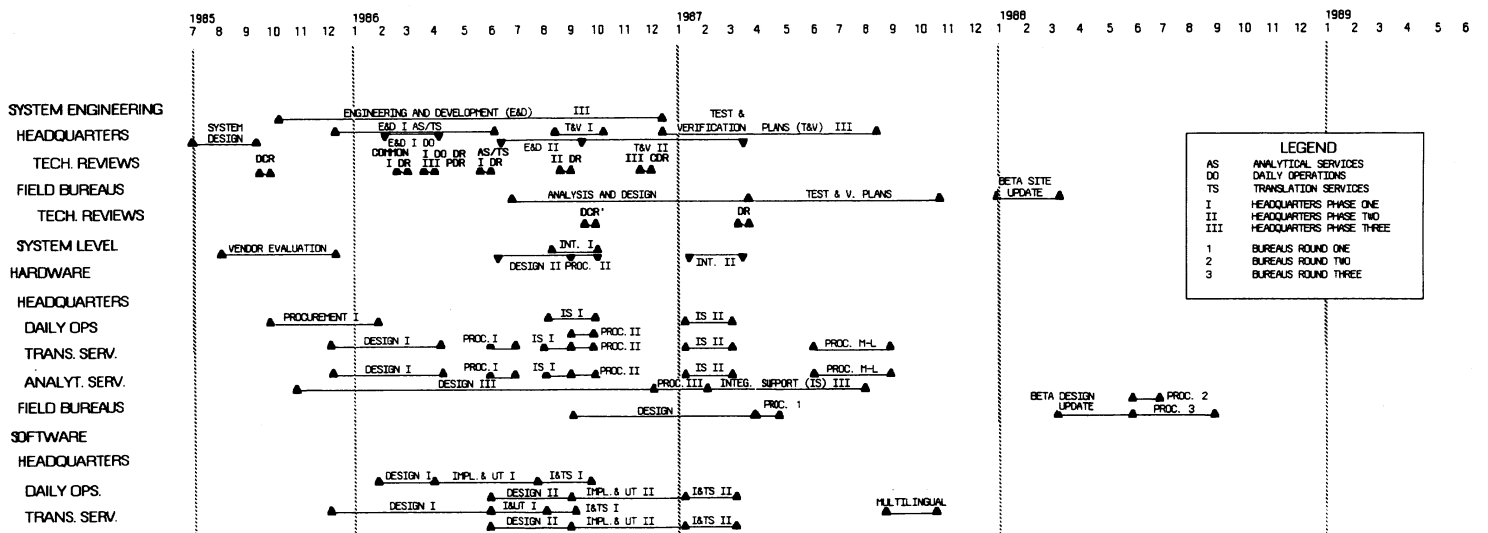

Figure 4-1a. FMS Development Schedule (Sheet 1 of 2)

Program Build Plan (PBP)

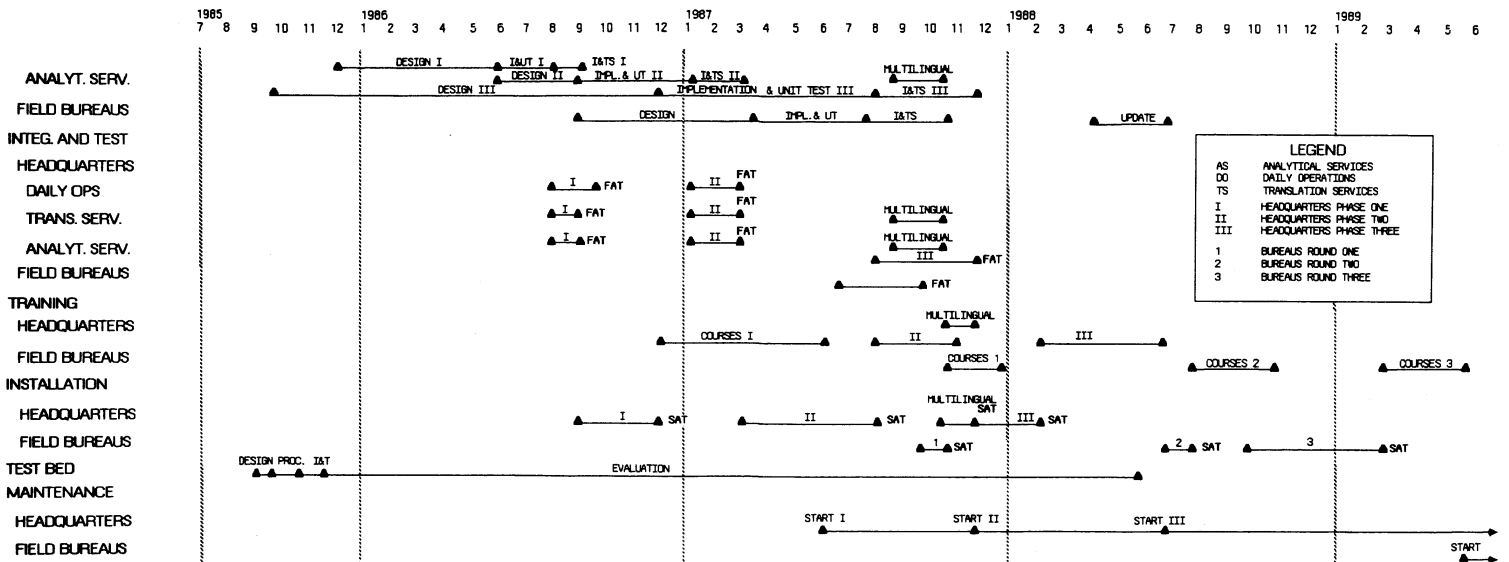

Figure 4-1a. FMS Development Schedule (Sheet 2 of 2)

Program Build Plan (PBP)

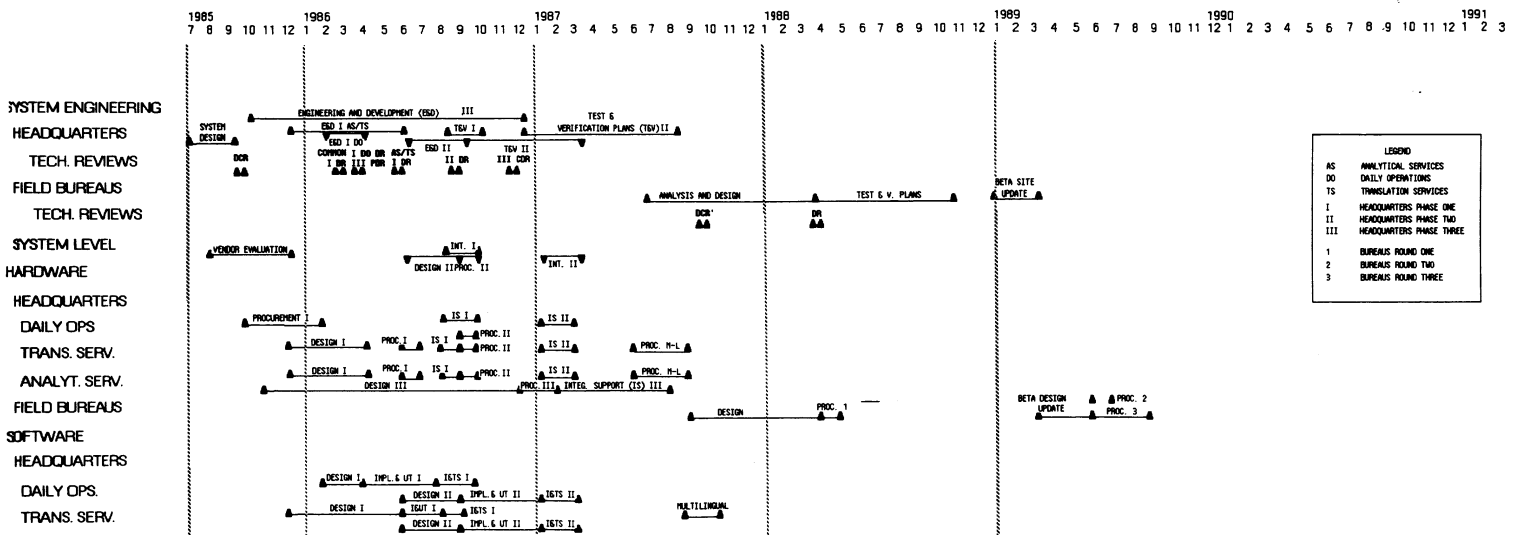

Figure 4-1b. FMS Development Schedule (Sheet 1 of 2)

Program Build Plan (PBP)

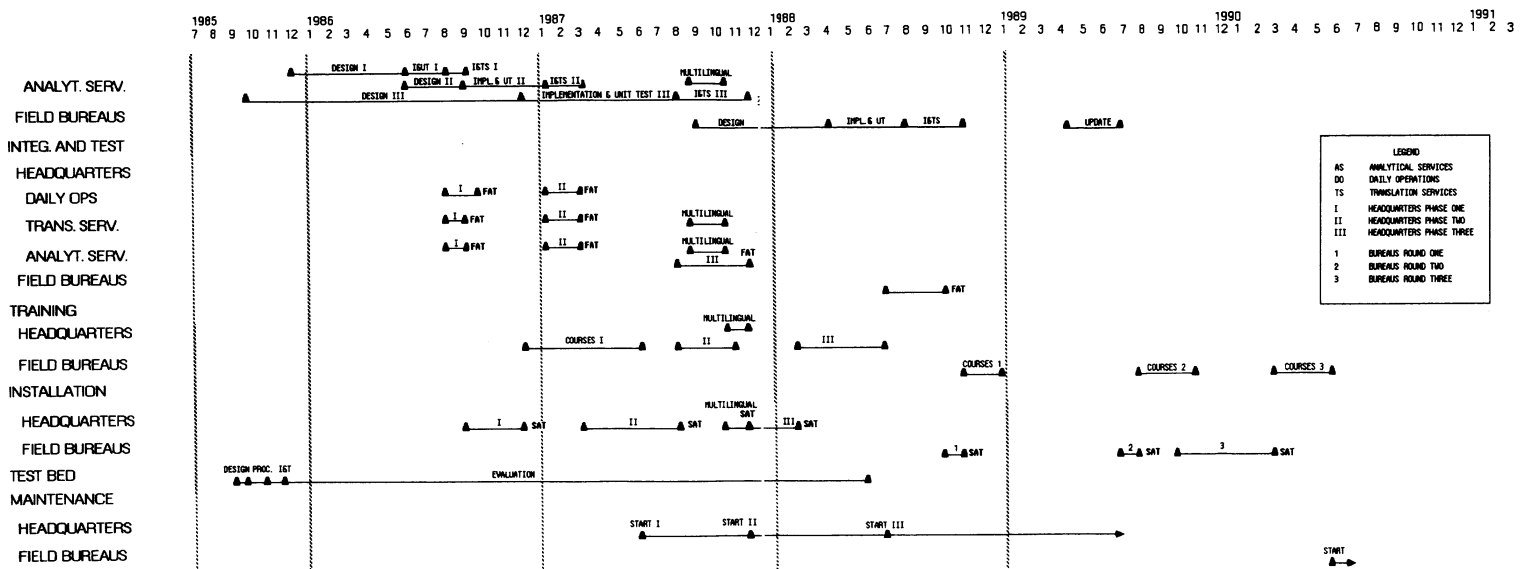

Figure 4-1b. FMS Development Schedule (Sheet 2 of 2)

Program Build Plan (PBP)

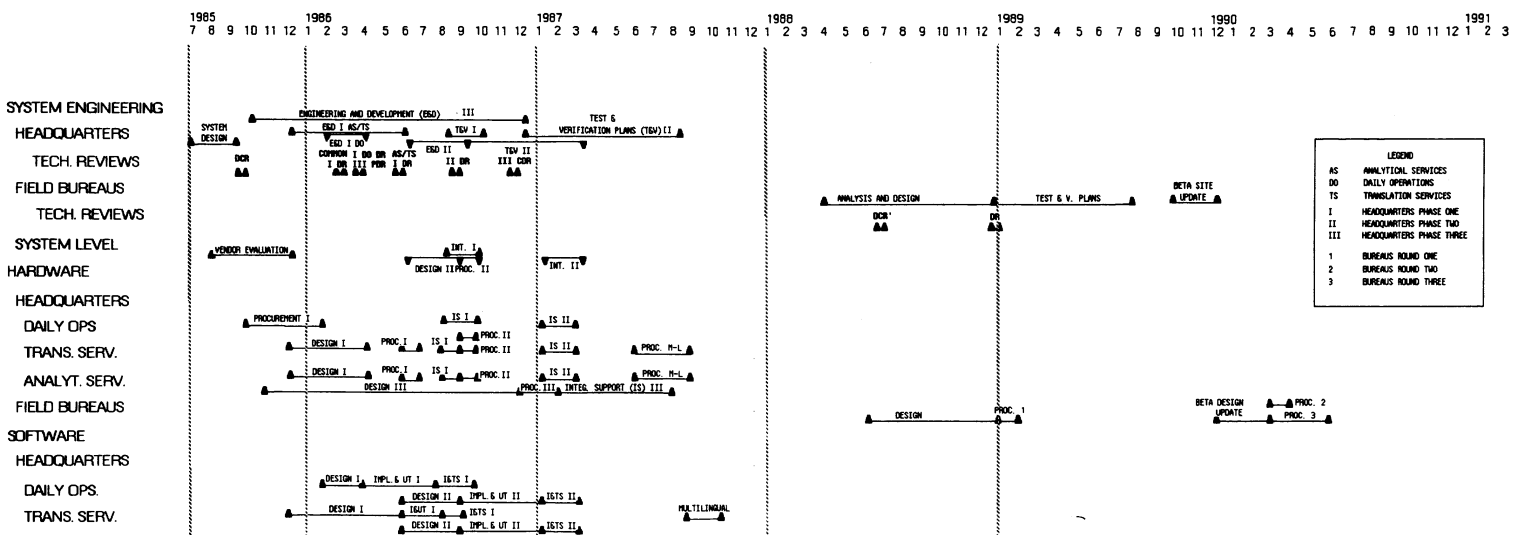

Figure 4-1c. FMS Development Schedule (Sheet 1 of 2)

Program Build Plan (PBP)

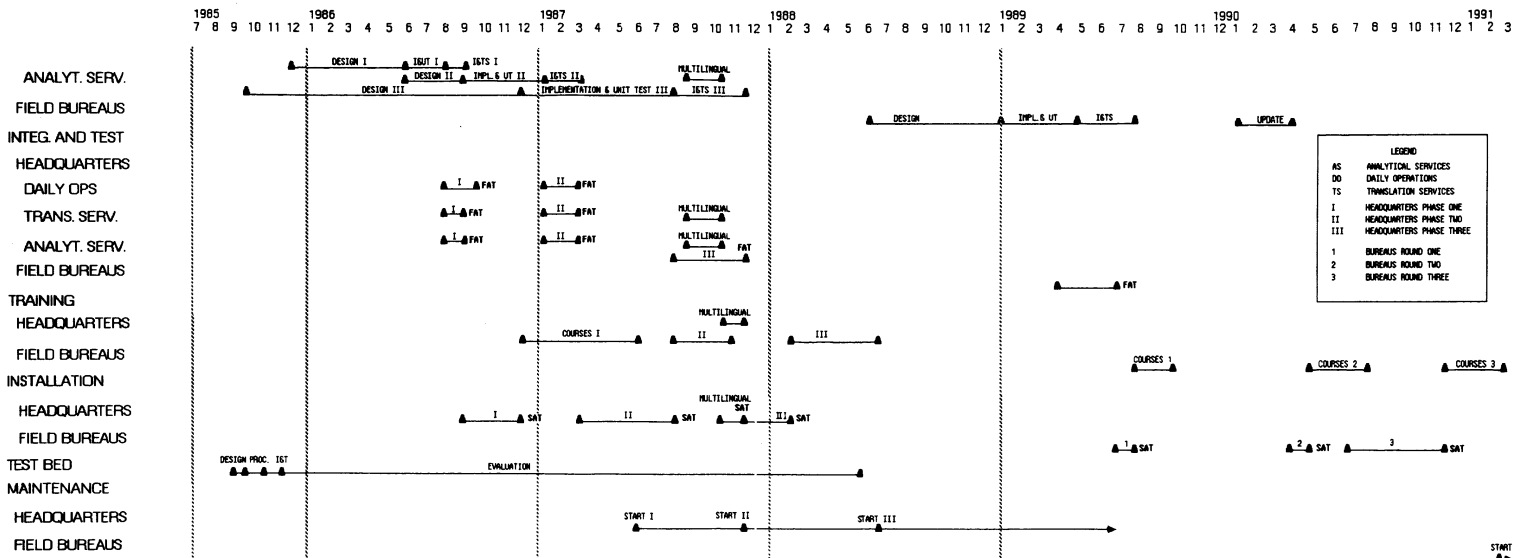

Figure 4-1c. FMS Development Schedule (Sheet 2 of 2)

APPENDIX A

MODIFIED BUREAU DESIGN DESCRIPTION

ESL
A Subsidiary of TRW

FBIS—INFORMATION PROCESSING SUBSYSTEM FUNCTIONAL BLOCK DIAGRAM

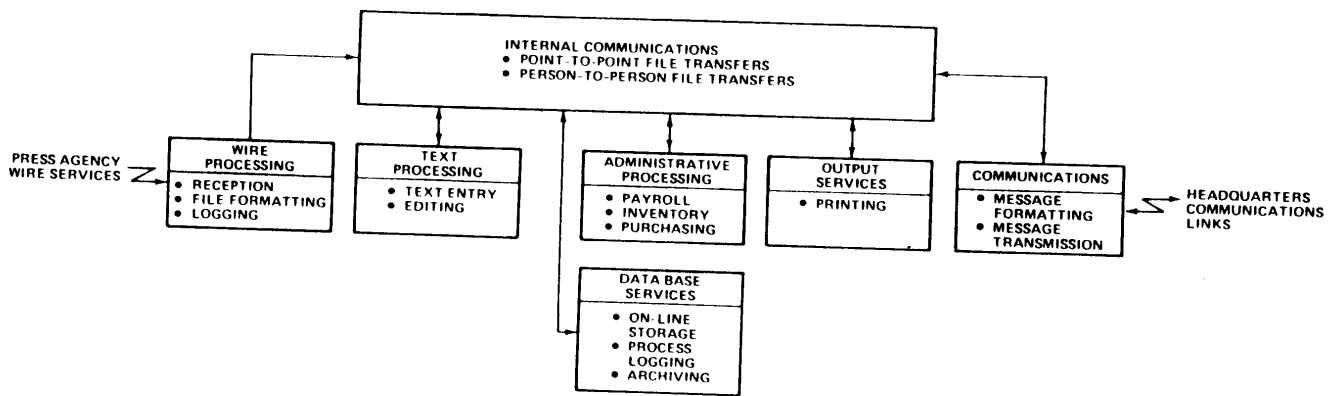

FBI-BUREAU HARDWARE BLOCK DIAGRAM

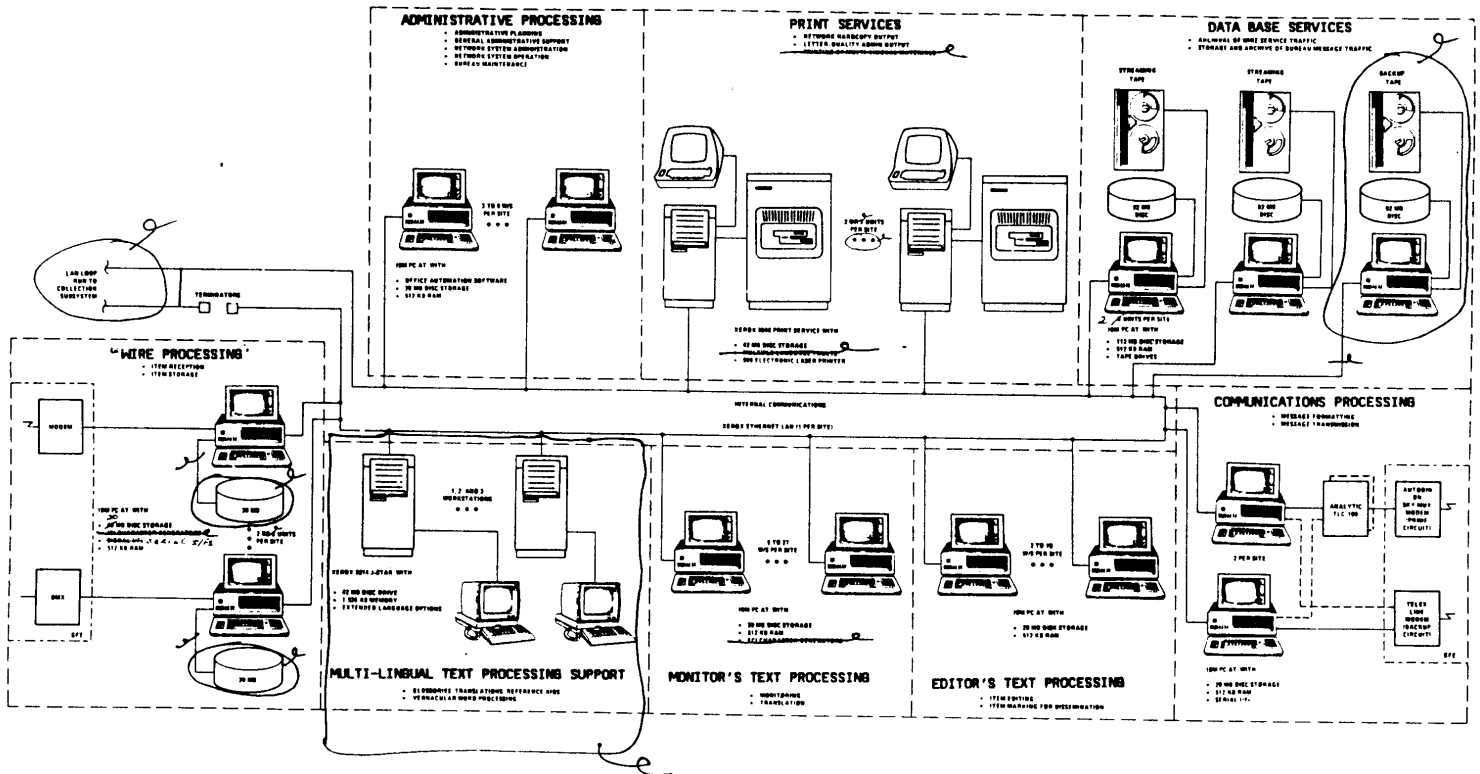

ESL
A Subsidiary of TRW

FBI-BUREAU HARDWARE BLOCK DIAGRAM

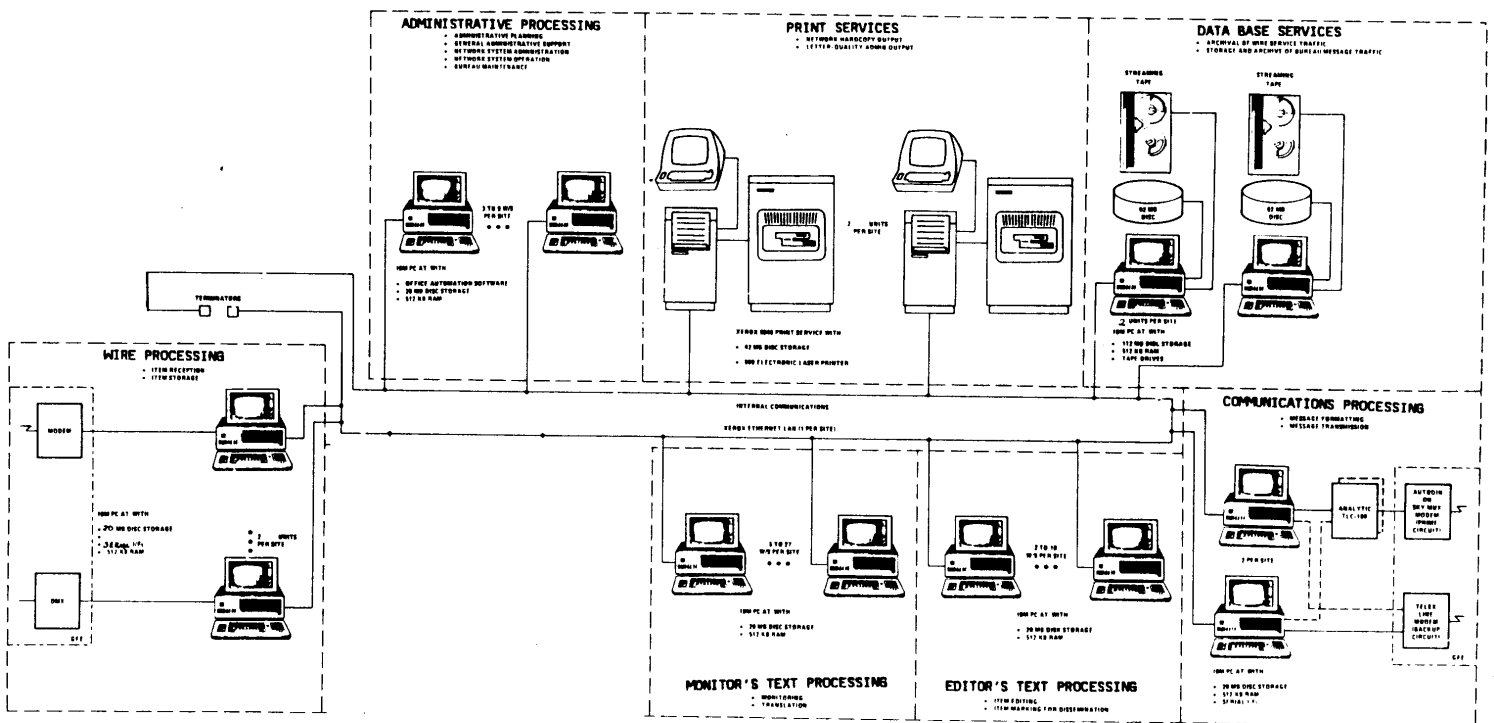

ESL
A Subsidiary of TRW

FBIS—BUREAU SOFTWARE HIERARCHY

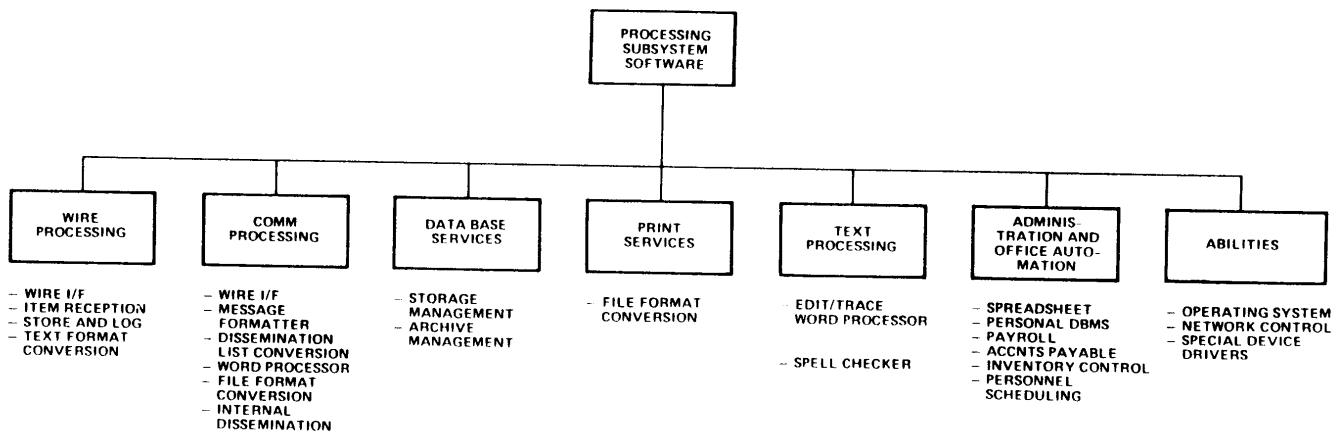

SV00007-8

ESL
A Subsidiary of TRW

FBIS - SUBSYSTEM INTERFACES

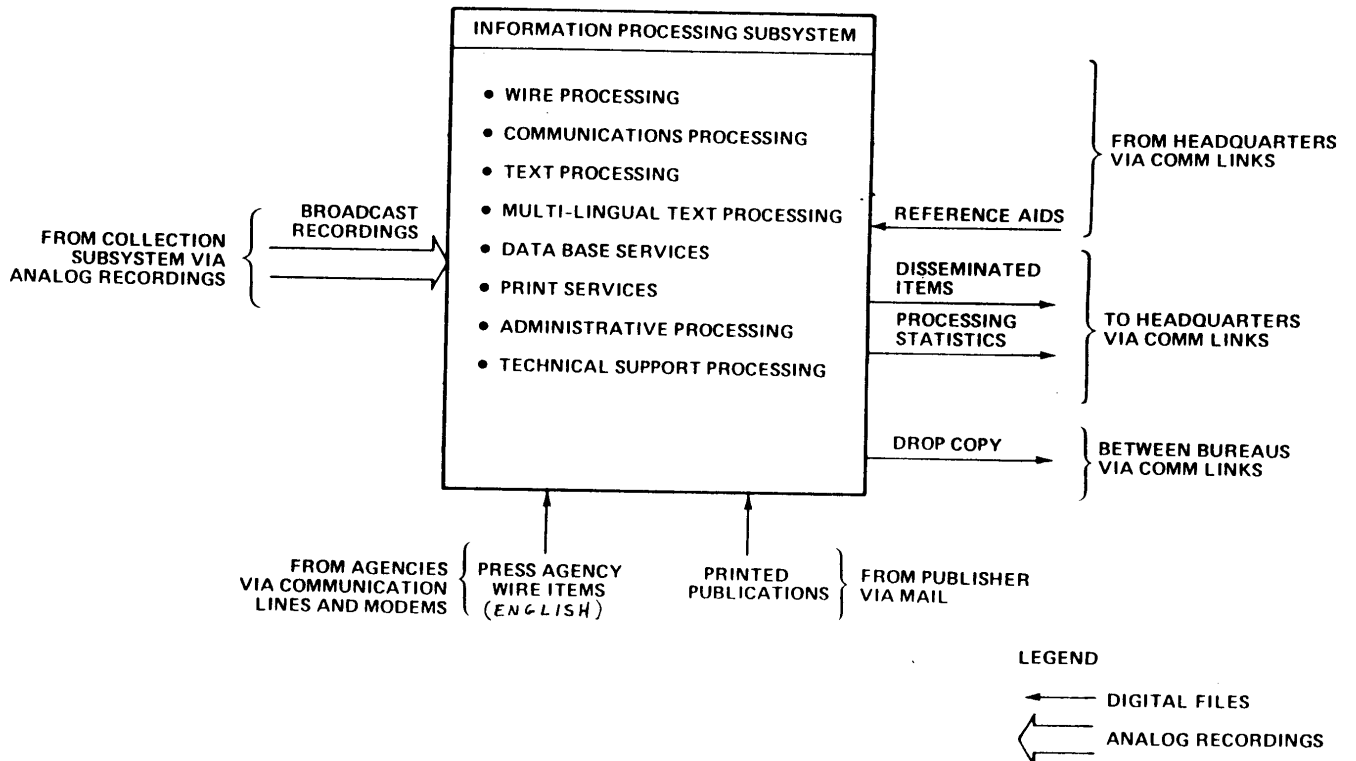

LOCAL AREA NETWORK

- 0 XEROX ETHERNET LOCAL AREA NETWORK
- 0 CABLE & IBM PC ETHERNET INTERFACE CARDS SUPPLIED BY XEROX
- 0 NETWORK RUNS XNS PROTOCOLS
- 0 COAX CABLE IS TEFLON COATED, MEETS TEMPEST SPECS
- 0 ETHERNET HAS A 10 MBIT/SEC PERFORMANCE
- 0 10 MBITS/SEC GREATLY EXCEEDS BUREAU PERFORMANCE REQUIREMENTS:
PERMITS 72 SIMULTANEOUS USERS TO EACH TRANSMIT
OVER 8 TYPEWRITTEN PAGES EVERY SECOND

PRINT SERVER

- 0 CONSISTS OF XEROX 8046 ETHERNET PRINT SERVER
 - INCLUDES MODEL 909 HIGH QUALITY (300 LPI) LASER PRINTER
 - 42 MBYTE RIGID DISK DRIVE
 - CLASSIC AND MODERN FONTS

- 0 XEROX SUPPORTS USE OF PRINT SERVER BY IBM PCs BY ACCEPTING TEXT FILES IN AN APPROVED FORMAT

- 0 FORMAT CONVERSION SOFTWARE RUNS ON THE IBM PCs
 - CONVERTS FROM XYWRITE TO XEROX FORMAT

WIRE SERVER

HARDWARE

- 0 IBM PC AT, MODEL 99
- 0 NETWORK INTERFACE

- 0 TWO, SERIAL INTERFACE CARDS TO ACCEPT OUTPUT FROM LINE MODEMS OR RADIO TELETYPE DEMULTIPLEXERS

SOFTWARE

- 0 WIRE SERVICE EXECUTIVE PROGRAM
 - PROVIDES CHARACTER AND FORMAT CONVERSION
 - FORMATS ITEMS INTO STANDARD FBIS MESSAGE FORMAT
 - LOGS EACH RECEIVED ITEM
 - STORES EACH ITEM ON LOCAL DISK
 - MAKES A BACKUP COPY OF EACH ITEM IN THE DATA BASE SERVER

COMMUNICATIONS SERVER

HARDWARE

- 0 IBM PC AT, MODEL 99
- 0 NETWORK INTERFACE
- 0 TWO, TELECOMMUNICATION LINE CONTROLLERS
 - FIRST UNIT IS PRIME UNIT, ALWAYS IN USE
 - SECOND UNIT IS READY AS A STANDBY
- 0 TWO, SERIAL INTERFACES
 - FIRST INTERFACE CONNECTS TO THE TLC
 - SECOND INTERFACE CONNECTS THE SERVER TO BACKUP CIRCUIT
- 0 TWO SERVERS PER BUREAU, CROSS-COUPLED TO EACH CIRCUIT

SOFTWARE

- 0 COMM SERVER EXECUTIVE PROGRAM
 - PROVIDES CHARACTER CONVERSION
 - PERFORMS MESSAGE AND MULTI-TAKE FORMATTING
 - LOGS EACH TRANSMISSION
 - UPDATES THE STATUS OF EACH ITEM IN SOURCE SUMMARY
 - STORES A COPY OF EACH TRANSMISSION IN THE DATA BASE SERVER FOR ARCHIVING

DATA BASE SERVER

HARDWARE

- 0 IBM PC AT, MODEL 99
- 0 NETWORK INTERFACE
- 0 ADDITIONAL 92 MBYTES DISK STORAGE
- 0 DOUBLE-DUTY TAPE DRIVE: STREAMING OR START/STOP MODE
- 0 SIZED TO HANDLE
 - WIRE ARCHIVE TRAFFIC
 - COMMUNICATIONS TRAFFIC ARCHIVE
 - ASSORTED MASTER VERSIONS OF SOURCE SUMMARIES, REFERENCE AIDS, BUREAU FILES

SOFTWARE

- 0 PERFORMS ONLINE STORAGE MANAGEMENT AND DATA ACCESS
- 0 ALSO RESPONSIBLE FOR OFFLINE STORAGE MANAGEMENT, ARCHIVING, AND ARCHIVE RETRIEVAL
- 0 USER INTERFACE TO DATA BASE SERVER DATA BASES IS WITH 'RECORD KEEPER'

MONITORS' PC W/S

HARDWARE

- 0 IBM PC AT, MODEL 99
- 0 NETWORK INTERFACE

SOFTWARE

- 0 XYWRITE II-PLUS WORD PROCESSOR
 - USED FOR TRANSLATION
- 0 WORD PROOF SPELL CHECKER
- 0 'RECORD KEEPER' -- USER INTERFACE TO DBMS
- 0 'TASK KEEPER' -- USER INTERFACE TO ADMINISTRATION FILES

EDITORS' PC W/S

HARDWARE

- 0 IBM PC AT, MODEL 99
- 0 NETWORK INTERFACE

SOFTWARE

- 0 XYWRITE II-PLUS WORD PROCESSOR
 - USED FOR EDITING
- 0 WORD PROOF SPELL CHECKER
- 0 'RECORD KEEPER' -- USER INTERFACE TO DBMS
- 0 'TASK KEEPER' -- USER INTERFACE TO ADMINISTRATION FILES

ADMINISTRATIVE PC WORKSTATIONS

HARDWARE

- 0 IBM PC AT, MODEL 99
- 0 NETWORK INTERFACE

SOFTWARE

- 0 XYWRITE II-PLUS FOR WORD PROCESSING
- 0 "WORD PROOF" SPELLING CHECKER
- 0 ASSORTED OFFICE AUTOMATION SOFTWARE PACKAGES
 - SYMPHONY, FOR SPREADSHEETS AND PERSONAL DATA BASES
 - PAYROLL
 - INVENTORY CONTROL
 - ACCOUNTS PAYABLE

ENGINEERS' & TECHNICIANS' PC WORKSTATIONS

HARDWARE

- 0 IBM PC AT, MODEL 99
- 0 NETWORK INTERFACE

SOFTWARE

- 0 XYWRITE II-PLUS FOR WORD PROCESSING
- 0 "WORD PROOF" SPELLING CHECKER
- 0 ASSORTED OFFICE AUTOMATION SOFTWARE PACKAGES
 - INVENTORY CONTROL

BUREAU CONFIGURATION (1 OF 3)

BUREAU: ABIDJAN AUSTRIAN BANGKOK GULF HONG KONG JORDAN

ITEM DESCRIPTIONS

LAN NETWORK:

LAN	1	1	1	1	1	1	1
-----	---	---	---	---	---	---	---

NETWORK SERVERS:

PRINT SERVER	2	2	2	2	2	2	2
WIRE SERVER	2	3	2	1	0	2	2
COMM SERVER	2	2	2	2	2	2	2
FILE SERVER	2	2	2	2	2	2	2

PC WORKSTATIONS:

MONITORS' W/S	10	26	23	12	26	8
EDITORS' W/S	2	4	5	2	5	2
ADMIN. W/S	2	3	4	2	3	3
ENG/TECH W/S	1	1	1	1	1	1
	15	34	33	17	35	14

BUREAU CONFIGURATION (2 OF 3)

BUREAU:	KEY WEST	LONDON	PMU	NICOSIA	OKINAWA	PANAMA
ITEM DESCRIPTIONS						

LAN NETWORK:						
LAN	1	1	0	1	1	1
NETWORK SERVERS:						
PRINT SERVER	2	2	0	2	2	2
WIRE SERVER	1	9	0	1	5	1
COMM SERVER	2	2	0	2	2	2
FILE SERVER	2	2	0	2	2	2
PC WORKSTATIONS:						
MONITORS' w/s	5	5	17	14	27	14
EDITORS' w/s	0	10	5	3	8	4
ADMIN. w/s	2	6	1	2	8	4
ENG/TECH w/s	1	1	0	1	1	1
	<u>8</u>	<u>22</u>	<u>23</u>	<u>20</u>	<u>44</u>	<u>23</u>

BUREAU CONFIGURATION (3 OF 3)

BUREAU:	PARAGUAY	SEOUL	SWAZILAND	TEL AVIV
<u>ITEM DESCRIPTIONS</u>				
LAN NETWORK:				
LAN	1	1	1	1
NETWORK SERVERS:				
PRINT SERVER	2	2	2	2
WIRE SERVER	0	1	1	1
COMM SERVER	2	2	2	2
FILE SERVER	2	2	2	2
PC WORKSTATIONS:				
MONITORS' w/s	11	13	8	11
EDITORS' w/s	2	2	2	2
ADMIN. w/s	2	2	2	3
ENG/TECH w/s	1	1	1	1
	<u>16</u>	<u>18</u>	<u>13</u>	<u>17</u>

BUREAU SOFTWARE SIZING

SOFTWARE DESCRIPTION	ESTIMATED LOC
0 WIRE PROCESSING	
- OPERATOR INTERFACE	250
- LINE INTERFACE	250
- CHARACTER FORMAT CONVERSION	500
- ITEM RECEPTION	250
- FILE STORAGE	500
- WIRE RECEIPT LOGGING	500
- INTERACTIVE WIRE FORMAT DEFINITION	1,200
	3,450
0 COMM. PROCESSING	
- OPERATOR INTERFACE	250
- FILE FORMAT CONVERSION	750
- DISSEMINATION LIST PROCESSING	500
- MESSAGE FORMATTING	1,000
- CHARACTER FORMAT CONVERSION	1,000
- LINE INTERFACE	250
- FILE STORAGE	500
- COMMUNICATIONS LOGGING	750
- INTERNAL DISSEMINATION	500
- DIGITAL FILE FORMAT CONVERSION	250
- PRODUCE VARIATIONS FOR EACH OF 4 PROTOCOLS	1,350
	7,100

BUREAU SOFTWARE SIZING (CONT.)

<u>SOFTWARE DESCRIPTION</u>	<u>ESTIMATED LOC</u>
0 DATA BASE SERVICES	
- STORAGE MANAGEMENT	2,500
- ARCHIVE MANAGEMENT	750
- USER INTERFACE ('RECORD KEEPER')	1,000
	<u>4,250</u>
0 PRINT SERVICES	
* WORD PROCESSOR FILE FORMAT CONVERSION	[750]
	<u>0</u>
0 TEXT PROCESSING	
* EDIT/TRACE ENHANCEMENTS TO XYWRITE	[1,000]
- MENU	500
	<u>500</u>
0 ADMIN/AUTOMATION	
- PERSONNEL/COVERAGE SCHEDULING	1,500
- USER INTERFACE ('TASK KEEPER')	500
	<u>2,000</u>
* --> INDICATES THE REQUIRED SOFTWARE WILL BE PRODUCED AS A HEADQUARTERS DEVELOPMENT ACTIVITY	

BUREAU SOFTWARE EFFORT SUMMARY

<u>SOFTWARE DESCRIPTION</u>	<u>ESTIMATED LOC</u>
0 WIRE PROCESSING	3,450
0 COMM. PROCESSING	7,100
0 DATA BASE SERVICES	4,250
0 PRINT SERVICES	0
0 TEXT PROCESSING	500
0 ADMIN/AUTOMATION	2,000
	<u>17,300</u>

APPENDIX B

MODIFIED HEADQUARTERS DESIGN DESCRIPTION

ESL
A Subsidiary of TRW

FBIIS - DAILY OPERATIONS

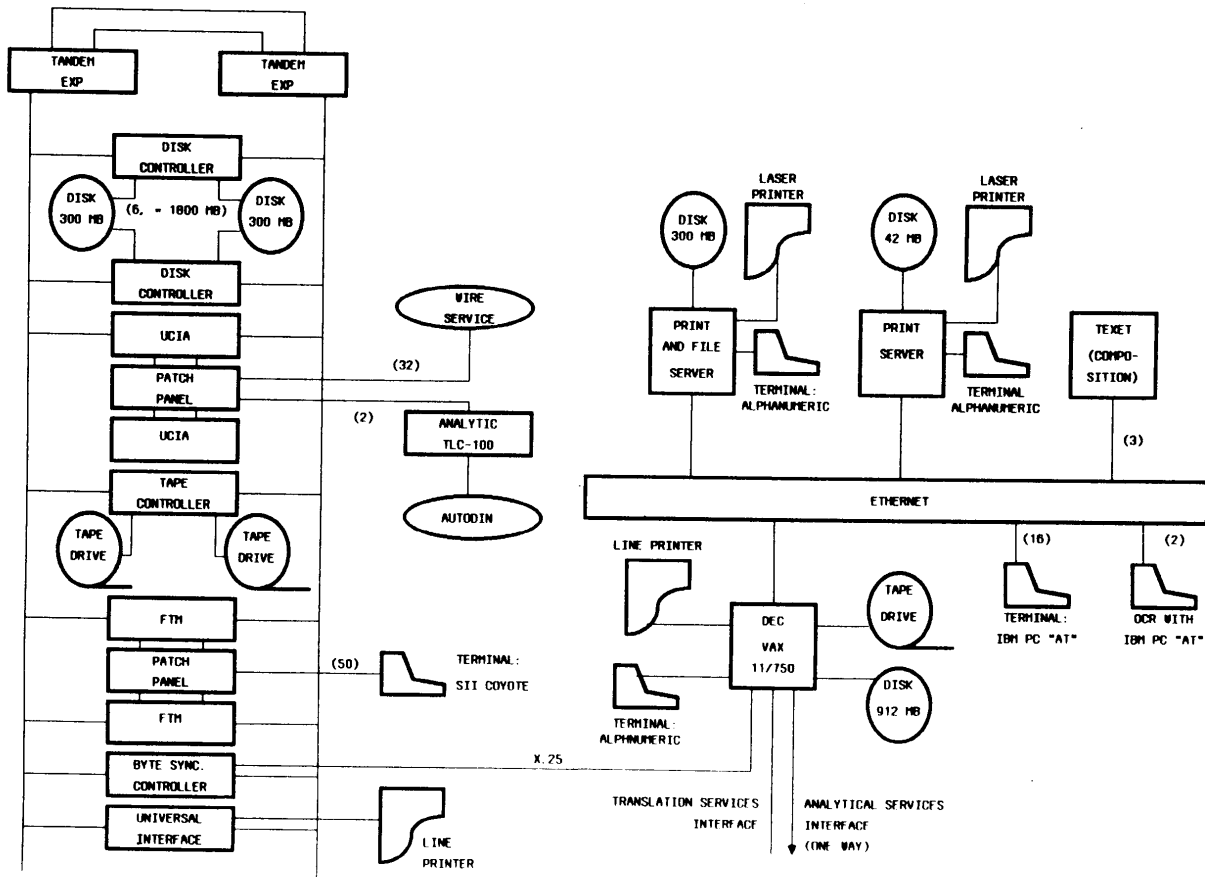

ESL
A Subsidiary of TRW

FBIS-TRANSLATION SERVICES

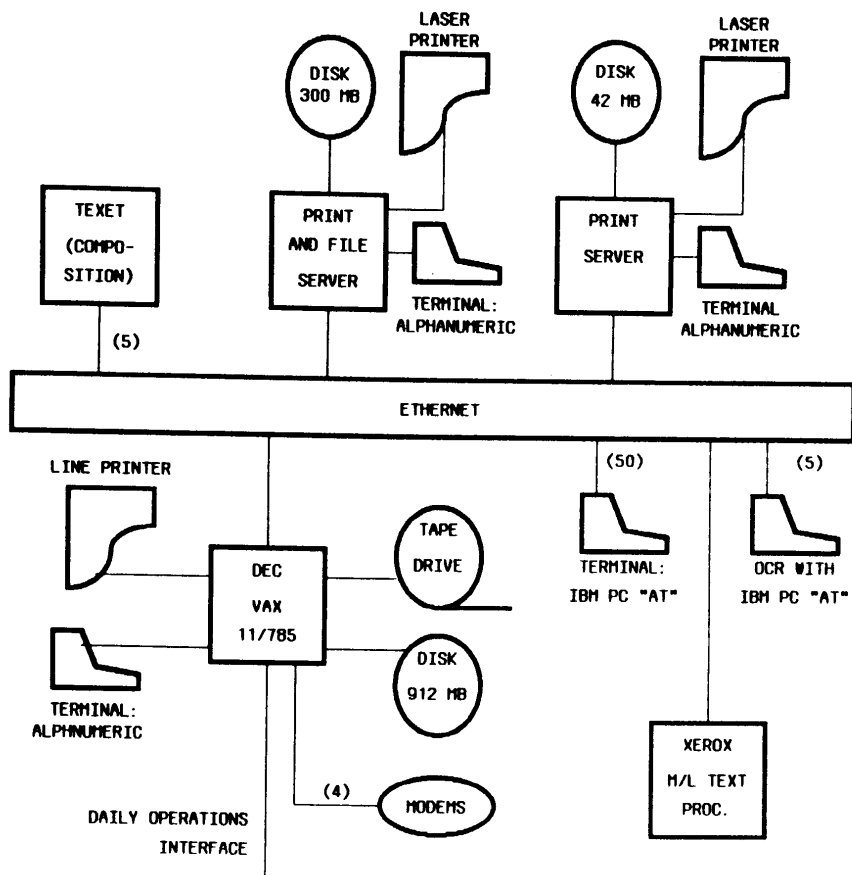

ESL
A Subsidiary of TRW

FBIS-ANALYTICAL SERVICES

