

USSR

UDC 547.341'139.61+547.391

PUDOVIK, A. N., BATIYEVA, E. S., SHAGIDULLIN, R. R., RAYEVSKIY, O. A.,
PUDOVIK, M. A., Institute of Organic and Physical Chemistry imeni A. Ye.
Arbuzov, Academy of Sciences USSR

"Reaction of Amides of Diphenylphosphinous Acid with α , β -Unsaturated Acids"

Leningrad, Zhurnal Obshchei Khimii, Vol 40, No 6, Jun 70, pp 1195-1202

Abstract: The mechanism of the reaction of diphenylphosphinous acid amides with α , β -unsaturated acids was investigated. Protonation of the nitrogen atom of the amide leads to the formation of an amine and subsequently the amide of the unsaturated acid and diphenylphosphinous acid. Association of the latter leads to the final product, namely β -carbamoyl-alkyl-or alkenyl-diphenylphosphine oxide, depending on whether an α , β -unsaturated acid of the ethylene or acetylene series was used. The proposed mechanism was confirmed by IR spectrometry.

1/1

- 37 -

USSR

UDC 547.341'139.81 + 547.391

PUDOVIK, A. N., BATYYEVA, E. S., and NESTERENKO, V. D.

"Reaction of Phenylsulfamide of Diphenylphosphinous Acid with Benzaldehyde"

Leningrad, Zhurnal Obshchey Khimii, Vol 40, No 2, Feb 70, pp 502-503

Abstract: Phenylsulfamide of diphenylphosphinous acid reacts energetically with benzaldehyde in the absence of a catalyst to give a crystalline product of composition 1 : 1; representing phenylsulfamide of diphenyl(α -hydroxybenzyl)phosphine.

1/1

- 71 -

USSR

UDC 547.261.118.07

PUDOVNIK, A. N., BATYYEVKA, Ye. S., and NESTERENKO, V. D., Institute of Organic and Physical Chemistry imeni A. Ye. Arbuzov

"A Method of Synthesizing O,O-Dialkyl-O-Dichlorovinyl-N-Acylimidophosphates"

Moscow, Otkrytiya, Izobreteniya, Promyshlennyye Obraztzy, Tovarnyye Znaki, No 16, Jun 73, Author's Certificate No 375297, Division C, filed 27 Sep 71, published 23 Mar 73, p 51

Translation: This Author's Certificate introduces a method of synthesizing O,O-dialkyl-O-dichlorovinyl-N-acylimidophosphates of the general formula

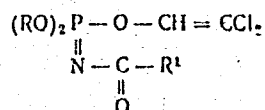

where R and R¹ are an alkyl. As a distinguishing feature of the patent, an O,O-dialkyl-N-acylamidophosphite is reacted with chloral in an organic solvent such as benzene in the presence of a hydrogen chloride acceptor such as trimethylamine with subsequent isolation of the goal product by conventional methods.

1/1

- 25 -

USER

BAUER, F. L.

"Programming Languages from the Educational and Professional Points of View"

VKP-2 Tr. 2-y Vses. Konf. po Programmir., 1970, Dokl. in. Uchastnikov [VKP-2 Works of Second All-Union Conference on Programming, 1970, Reports of Foreign Participants -- Collection of Works], Novosibirsk, 1971, pp 3-10, (Translated from Referativnyy Zhurnal, Kibernetika, No 2, 1972, Abstract No 2 V678 by V. Mikheyev).

Translation: The contradiction between the requirements of educational and professional uses for programming languages are discussed. The following educational requirements are noted: 1) basic concepts must exist; 2) basic concepts must be general, powerful and few in number; 3) simple and correctly defined rules for formation of other concepts from basic concepts must exist; 4) construction of concepts must be recursive: a complex concept must be able to be looked upon as a simple concept and used for construction of new, more complex concepts; 5) all prevailing languages must be based on the same basic concepts; 6) the method of description of programming languages must contain means of formation of new concepts; 7) the rules of construction of
1/2

USSR

BAUER, F. L., VKP-2 Tr. 2-y Vses. Konf. po Programmir., 1970. Dokl. in. Uchastnikov, Novosibirsk, 1971, pp 3-10.

new concepts must be universal. On the other hand, the general requirements of the professional programmer are: computer systems used must allow effective realization of a broad class of possible programming languages, each of which is in conceptual agreement with the textbook language or language which the programmer himself learns.

2/2

USSR

UDC 547.26'118 + 547.245

SAVAL'YEVA, N. I., KOSTYUK, A. S., BAUKOV, Yu. I., and LUTSENKO, I. F., Moscow State University imeni M. V. Lomonosov

"Reaction of Trialkylsilylketenes With Dialkyl Phosphites and Dialkyl thiophosphates"

Leningrad, Zhurnal Obshchey Khimii, Vol 41 (103), No 2, Feb 71, pp 485-486

Abstract: Dimethyl esters of α -trimethylsiloxyvinylphosphonic acid, b.p. $79^{\circ}/2\text{mm}$, n_D^{20} 1.4378, d_4^{20} 1.0556 and λ -trimethylsiloxyvinylthiophosphonic acid b.p. $83^{\circ}/2\text{mm}$, n_D^{20} 1.4740, d_4^{20} 1.1214 were synthesized by the reaction of trialkylsilylketenes with dialkyl phosphites and dialkyl thiophosphites in presence of catalytic amounts of triethylamine. It is proposed that formation of the esters $\text{CH}_2\text{C}(\text{OSiR}_3)\text{P}(\text{X})(\text{OR})_2$ is a secondary process going through the formation of $[\text{R}_3\text{SiCH}_2(\text{CO})\text{P}(\text{X})(\text{OR})_2]$ analogously to the reaction of dialkyl phosphites and thiophosphites with ketene.

1/1

1/2 011 UNCLASSIFIED PROCESSING DATE--27NOV70
TITLE--O AND C, HETEROORGANIC ISOMERS. XI. REACTION OF KETENE WITH
TRIALKYL SILDIALKYLAMINES -U-
AUTHOR--(03)-KOSTYUK, A.S., BAUKOV, YU.I., LUTSENKO, I.F.
COUNTRY OF INFO--USSR **B**
SOURCE--ZH. OBSHCH. KHIM. 1970, 40(3), 626-36
DATE PUBLISHED-----70
SUBJECT AREAS--CHEMISTRY
TOPIC TAGS--KETONE, ORGANOSILICON COMPOUND, AMINE, SILANE, ISOMER, VINYL
COMPOUND, ACETIC ACID
CONTROL MARKING--NO RESTRICTIONS
DOCUMENT CLASS--UNCLASSIFIED
PROXY REEL/FRA--3006/1427 STEP NO--UR/0079/70/040/003/0626/0636
CIRC ACCESSION NO--AP0135101

2/2 011

UNCLASSIFIED

PROCESSING DATE--27NOV70

CIRC ACCESSION NO--AP0135101

ABSTRACT/EXTRACT--(U) GP-0- ABSTRACT. R SUB3 SINR SUB2 REACT WITH H SUB2 C:CO ALONG ONE OF 3 PATHS DEPENDING ON STRUCTURE OF THE STARTING SILANES, BUT THE PRIMARY PRODUCTS ARE O DERIVS. WHICH ISOMERIZE INTO C DERIVS. OR REACT WITH H SUB2 C:CO TO YIELD VINYLACETIC ACIDS. (REACTIONS SHOWN ON MICROFICHE)

1/2 008 UNCLASSIFIED PROCESSING DATE--30OCT70
TITLE--O AND C, ORGANOMETAL, METALLOID, ISOMERS. IX. BETA, SILOXYVINYLACETIC
ACID ESTERS -U-
AUTHOR--(03)-BURLACHENKO, G.S., BAUKOV, YU.I., LUTSENKO, I.F.
COUNTRY OF INFO--USSR ~~_____~~ B
SOURCE--ZH. OBSHCH. KHIM. 1970, 40(1), 97-104
DATE PUBLISHED-----70
SUBJECT AREAS--CHEMISTRY
TOPIC TAGS--ISOMERIZATION, ACETIC ACID, ESTER, ORGANOSILICON COMPOUND,
ORGANOGERMANIUM COMPOUND
CONTROL MARKING--NO RESTRICTIONS
DOCUMENT CLASS--UNCLASSIFIED
PROXY REEL/FRAME--1992/1741 STEP NO--UR/0079/70/040/001/0097/0104
CIRC ACCESSION NO--AP0112728
UNCLASSIFIED

2/2 008

UNCLASSIFIED

PROCESSING DATE--30OCT70

CIRC ACCESSION NO--AP0112728

ABSTRACT/EXTRACT--(U) GP-0-- ABSTRACT. REACTION OF O,SILYLATED KETENE
ACETALS WITH KETENES OPENS THE SI-O BOND AND FORMS ESTERS OF
SILOXYVINYLACETIC ACID, WHICH ARE EASILY ISOMERIZED INTO ESTERS OF
SILOXYCROTONIC ACID. SHOWN ON MICROFICHE. FACILITY: MOSK. GOS.
UNIV. IM. LOMONOSOVA. MOSCOW, USSR.

UNCLASSIFIED

1/2 011 UNCLASSIFIED PROCESSING DATE--230CT70
TITLE--REARRANGEMENT OF AMIDES OF TRIALKYLGGERMYLACETIC ACID TO
N, TRIALKYLGGERMYLACETAMIDES -U-
AUTHOR--(04)-BAUKOV, YU.I., BURLACHENKO, G.S., KOSTYUK, A.S., LUTSENKO,
I.F.
COUNTRY OF INFO--USSR *B*
SOURCE--ZH. OSHCH. KHIM. 1970, 40(3), 707
DATE PUBLISHED-----70
SUBJECT AREAS--CHEMISTRY
TOPIC TAGS--ORGANOGERMANIUM COMPOUND, ACETIC ACID, ACETAMIDE,
ISOMERIZATION, NMR SPECTRUM, ORGANOSODIUM COMPOUND, ORGANOSILICON
COMPOUND, INTERMOLECULAR MECHANICS
CONTROL MARKING--NO RESTRICTIONS
DOCUMENT CLASS--UNCLASSIFIED
PROXY REEL/FRAME--2000/0868 STEP NO--UR/0079/70/040/003/0707/0707
CIRC ACCESSION NO--AP0124531
UNCLASSIFIED

2/2 011

UNCLASSIFIED

PROCESSING DATE--23OCT70

CIRC ACCESSION NO--AP0124531

ABSTRACT/EXTRACT--(U) GP-0- ABSTRACT. HEATING ET SUB3 GECH SUB2 CONHME TO 140-50DEGREES RESULTS IN ITS ISOMERIZATION INTO ACNMEGEET SUB3, WHICH WAS CHARACTERIZED BY ITS NMR SPECTRUM, ALSO USED TO FOLLOW THE REACTION. CL SUB3 GECH SUB2 CL AND RMGX GAVE R SUB3 GE CH SUB2 CL, WHICH WITH MG AND CO SUB2 GAVE R SUB3 GECH SUB2 CO SUB2 H, WHICH WITH CH SUB2:CO GAVE R SUB3 GECH SUB2 CO SUB2 AC, WHICH BY LOSS OF AC SUB2 O GAVE (R SUB3 GECH SUB2 CO) SUB2 O, WHICH PYROLYZED TO R SUB3 GECH:CO AND R SUB3 GECH SUB2 CO SUB2 H; THE YIELD OF THE KETENE, B SUB15 69-71DEGREES, N PRIME20 SUBD 1.4600, REACHED 40PERCENT, AND INTERMEDIATE STEPS GAVE 60-80PERCENT YIELDS. ALTERNATIVELY, PHCH SUB2 CO SUB2 ME TREATED WITH NAN(SIME SUB3) SUB2, THEN ME SUB3 SICL, GAVE PHCH:C(OME)OSIME SUB3; WITH GECL SUB4 AT 30DEGREES THIS GAVE PHC(GECL SUB3):C(OME)OSIME SUB3, WHICH PYROLYZED TO ME SUB3 SIOME AND PHC(GECL SUB3):CO IN 54PERCENT YIELD, B SUB1 71-3DEGREES, N PRIME20 SUBD 1.5524. TRIETHYLGGERMYLKETENE AND MENH SUB2 GAVE ET SUB3 GECH SUB2 CONHME, 40PERCENT, B SUB0.05 98-9DEGREES, N PRIME20 SUBD 1.4821. FACILITY: MOSK. GOS. UNIV. IM. LOMONOSOVA, MOSCOW, USSR.

UNCLASSIFIED

Organophosphorous Compounds

USSR

UDC 541.49:547.558.1:541.1'13

NESMEYANOV, A. N., NEREVALOVA, E. G., BAUKOVA, T. V., GRANDBERG, K. I.

"Triphenylphosphine Complex of Cyclopentadienyl (Manganesedicarbonyltriphenylphosphine) Gold"

Moscow, Izvestiya Akademii Nauk SSSR, Seriya Khimicheskaya, No 11, 1973, pp 2641-2642

Abstract: The triphenylphosphine complex of cyclopentadienyl (manganesedicarbonyltriphenylphosphine) gold (II) was obtained:

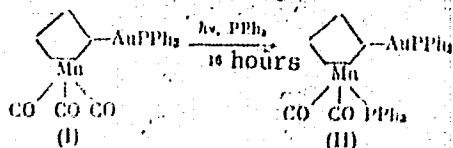

The structure of the (II) complex was established on the basis of spectral data and confirmed by the chemical behavior of the compound. In the infrared spectrum of (II) a shift of the two intense absorption bands of the CO groups toward the long-wave range is observed by comparison with the spectrum of 1/2

USSR

NESMEYANOV, A. N., et al., *Izvestiya Akademii Nauk SSSR, Seriya Khimicheskaya*, No 11, 1973, pp 2641-2642

cyclopentadienyltricarbonylmanganese (I). This usually occurs on replacement of one of the CO groups in the cymantrene by a stronger electron-donor ligand [Kursanov, D. N., et al., *Izv. AN SSSR, Ser. Khim.*, 2842, 1969]. In the paramagnetic resonance spectrum of (II) signals are revealed from the protons of the phosphine groups along with two multiplets of the protons of the substituted cyclopentadienyl ring shifted to the stronger field by comparison with the signals in (I). In the nuclear magnetic resonance spectrum of ^{31}P of (II), two signals of the phosphorus nuclei from nonequivalent triphenylphosphine groupings are observed.

When (II) reacts with concentrated hydrochloric acid, (III) and the triphenylphosphine complex of gold chloride are formed:

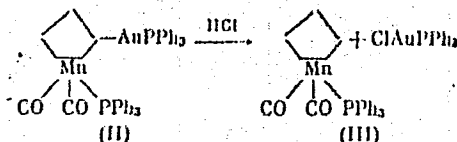

The complex (II) is less stable than (I) especially in solutions, and it decomposes during chromatographic studies in a column with aluminum oxide in contrast to (I).

2/2

Organometallic Compounds

USSR

UDC 547.13

GRANDBERG, K. I., BAUKOVA, T. V., PEREVALOVA, E. G., NESMEYANOV, A. N.,
Academician, Moscow State University imeni M. V. Lomonosov

"[ρ -Tolyl-(triphenylphosphine)-gold]-triphenylphosphinegold Borofluoride"

Moscow, Doklady Akademii Nauk SSR, Vol 206, No 6, 1972, pp 1355-1358

Abstract: The synthesis of [ferrocenyl-(triphenylphosphine)-gold]-triphenylphosphinegold borofluoride (I) -- a new type of organogold compound containing two gold atoms per molecule -- was reported earlier [E. G. Perevalova, et al., DAN., Vol 202, 97, 1972]. The formation of this type of complex is not a specific property of ferrocenyl-(triphenylphosphine)-gold. Organogold compounds of the benzene series -- ρ -tolyl-(triphenylphosphine)-gold (II) and phenyl-(triphenylphosphine)-gold (III) -- also react with HBF_4 yielding similar complexes; ρ -tolyl-(triphenylphosphine)-gold was obtained from ρ -tolyllithium and the triphenylphosphine complex of gold chloride. The reaction of II and III with an ether solution of HBF_4 leads to the formation of borofluorides of [ρ -tolyl-(triphenylphosphine)-gold]-triphenylphosphinegold (IV) and [phenyl-triphenylphosphine)-gold]-triphenylphosphinegold (V), respectively. The auriferous ligand $\text{CH}_3\text{C}_6\text{H}_4\cdot\text{Au}\cdot\text{P}(\text{C}_6\text{H}_5)_3$ in

1/2

USSR

GRANDBERG, K. I., et al., Doklady Akademii Nauk SSSR, Vol 206, No 6, 1972, pp 1355-1358

combination with IV is easily replaced by other electron donor ligands -- triphenylphosphine, morpholine, ferrocenyl-(triphenylphosphine)-gold. In the presence of an aqueous solution of sodium chloride, II and the triphenylphosphine complex of gold fluoride are formed. The paramagnetic resonance spectra and ultraviolet spectroscopic data of some of the above organogold compounds were analyzed. The experimental procedures and results for the reaction HBF_4 and II, HBF_4 and phenyl-(triphenylphosphine)-gold, an aqueous solution of sodium chloride and IV, IV and triphenylphosphine, IV and ferrocenyl-(triphenylphosphine)-gold, IV and morpholine, and IV and ferrocenyl-(triphenylphosphine)-gold are described.

2/2

USSR

UDC 547.13

PEREVALOVA, E. G., LEMENOVSKIY, D. A., BAUKOVA, T. V., SMYSLOVA, YE. I., GRANDBERG, K. I., and NESMEYANOV, A. N., Moscow State University imeni M. V. Lomonosov

"Reaction of Ferrocenyl- and Phenyl(triphenylphosphine)gold with Electrophilic Reagents"

Leningrad, Doklady Akademii Nauk SSSR, Vol 206, No 4, Oct 72, pp 883-996

Abstract: Reactions of ferrocenyl- and phenyl(triphenylphosphine)gold with electrophilic reagents was studied. No electrophilic substitution at the gold atom took place in these reactions, the products indicating that a homolytic process occurred in these reactions. For example, when ferrocenyl-(triphenylphosphine)gold reacted with acetic anhydride or acyl chlorides of acetic or trichloroacetic acids, only ferrocene, biferrocenyl and a salt of the composition $XAuP(C_6H_5)_3$, where $X = Cl$ or $OCOCH_3$, were formed. No acyl-ferrocene was isolated. Analogous reactions occur with phenyl(triphenylphosphine)gold, no electrophilic substitution taking place. The results obtained can be explained by the single electron transfer mechanism, this being the first step in a series of reactions. The electron from the C-Au bond is transferred to the splitting reagent, which acts as an electron acceptor.

1/1

USSR

UDC 614.484

BAUMAN, V. M., OBREKHT, S. D., SAAKOV, G. T., Col Med Serv; and FEDOROV, M. N.,
Candidate of Medical Sciences

"Gaseous Methods of Disinfection"

Moscow, Voenno-Meditsinskiy Zhurnal, No 10, 1972, pp 54-57

Abstract: Because there has been heretofore no practical solution to the problem of disinfecting synthetic materials, documents, currency devices, and small-size expensive apparatus, the authors devote this article to the status of the gaseous method of disinfection which they regard as the solution since, as recent research has shown, it is convenient and has no negative qualities. In this chamberless method, a promising disinfectant is a mixture of ethylene oxide and methyl bromide (known under the Russian acronym of OKEBM) which is prepared under industrial conditions and consists of one part ethylene and 2.5 parts methyl bromide by weight. It is a uniform, transparent fluid with a pungent odor, a liquid below +8.5° C under ordinary air pressure conditions, and is capable of being stored for long periods. A table of the antiseptic properties of the gas acting on various materials under various conditions is presented. The results of tests made to determine
1/2

USSR

BAUMAN, V. M., et al., Voenno-Meditsinskiy Zhurnal, No 10, 1972, pp 54-57

its germicidal capacity are also given together with a sketch of the equipment used for administering it. Research performed by the authors shows that the gaseous method of disinfection may become standard under field and barracks conditions. It is also applicable to surgery and other hospital procedures.

2/2

USSR

UDC 542.957+541.57+546.59+546.26

PEREVALOVA, E. G., BAUKOVA, T. V., GORYUNOV, Ye. I., and GRANDBERG, K. I.,
Institute of Organoelemental Compounds, Academy of Sciences of the USSR

"Splitting of the Gold-Carbon Bond in Phenylgold Triphenylphosphine"

Moscow, IAN SSSR, Seriya Khimicheskaya, No 9, Sep 70, pp 2,148-2,150

Abstract: The authors investigated the reactivity of the Au-C bond in phenylgold triphenylphosphine. It was found that interaction of hydrogen chloride gas, or aqueous and alcohol solutions of hydrogen chloride with a benzene solution of phenylgold triphenylphosphine (I) produces gold chloride triphenylphosphine (II).

Reaction of concentrated hydrogen bromide and hydrogen iodide solutions with (I) gives gold bromide triphenylphosphine and gold iodide triphenylphosphine in quantitative yields. Reaction of (I) with halogens at 15°C also breaks the Au-C bond with the formation of triphenylphosphine complexes of halide salts of univalent gold.

The bond is also broken by acetyl chloride, trifluoroacetic acid anhydride and
1/2

USSR

PEREVALOVA, E. G., et al, IAN SSSR, Seriya Khimicheskaya, No 9, Sep 70, pp 2,148-2,150

mercuric chloride. However, it was found that the Au-C bond is resistant to alkaline agents. The phenyl radical formed by splitting of the bond will be studied in a future paper.

2/2

- 59 -

USSR

UDC: 621.44

PEREL'MAN, R. G., Candidate of Technical Sciences, Docent, BAULIN, V. I., Assistant and DENISOV, YU. D., Graduate Student

"The Role of Dynamic Stresses During Droplet Impact Erosion"

Moscow, Izvestiya Vysshikh Uchebnykh Zavedeniy, Mashinostroyeniye, No 5, 1973, pp 64-70

Abstract: The authors study the basic regularities associated with the droplet impact erosion of the blades of wet-steam turbines during the period of discovered damage on the basis of analyzing the dynamic stresses in an elastic half-space during its collision with a droplet. The authors conclude that the cyclic effect of Rayleigh surface waves during this period represent the main damage factor. Experimental data are given which support the validity of the new droplet impact erosion model. This article was presented for publication by Professor G.S. Skubachevskiy of the Moscow Aviation Institute.

1/1

- 112 -

USSR

UDC: 621.652:669.018.95(088.8)

ARABEY, B. G., BAULIN, Yu. N., ZVEREV, I. I., ZUKHER, M. S., KOKONIN, S. S.,
MARKOV, Yu. M., PORTNOY, K. I., SKLYAROV, N. M., TYURIN, V. A.

"Metal Ceramic Friction Material"

USSR Author's Certificate Number 346373, Filed 15/12/69, Published 18/08/72
(Translated from Referativnyy Zhurnal Metallurgiya, No 8, 1973, Abstract No
8G422P, by S. Krivosova).

Translation: A metal ceramic friction material, for example for braking devices, is suggested, containing ZrC and B carbide. In order to increase the stability of the coefficient of friction, B nitride and metals of the Fe group are introduced to the composition, taken in any combination with the following ratio of components (in wt. %): B carbide -- 10-50, Fe-group metals, taken in any combination, 3-35, B nitride 1-5, ZrC -- remainder. The material suggested has the following properties: s. g. 5.52 g/cm³; coefficient of friction at braking temperature 600° 0.50-0.55, at 800° 0.45-0.50; stability of coefficient of friction with specific braking energies 450 kgm/cm² 0.75-0.88; at 923 kgm/cm² 0.80-0.95; wear with specific braking energies of 450 and 923 kgm/cm², in μ /torr 2-6 and 6-11 respectively; permissible volumetric

1/2

USSR

Arabey, B. G., Baulin, Yu. N., Zverev, I. I., Zukher, M. S., Kokonin, S. S., Markov, Yu. M., Portnoy, K. I., Sklyarov, N. M., Tyurin, V. A., USSR Author's Certificate Number 346373, Filed 15/12/69, Published 18/08/72.

temperature 800°, heat conductivity factor in t/m° at 100° 48.1, 200° 44.0, 400° 35.9, 600° 29.5, 800° 27.3, 1000° 26.4; specific heat capacity (in cal/g°) at 100° 0.134, 200° 0.136, 400° 0.150, 600° 0.161, 800° 0.169, 1000° 0.184; tensile strength at 20° 36 kg/mm^2 ; bending strength at 20° 62 kg/mm^2 ; shear strength at 20° 13.8 kg/mm^2 ; a_H 0.15 kg/cm^2 .

2/2

- 41 -

USSR

UDC 621.4/.6:533.6

LAZEREV, Ye. A., BAUL'KIN, A. V., LAVRIK, A. N., RASKIN, V. G.

"Determination of the Permissible Range of Variation in the Control Parameter of a Two-Stage Turbine in a Turbocompressor"

Sb. nauch. tr. Chelyabinsk. politekhn. in-ta (Collected Scientific Works of the Chelyabinsk Polytechnical Institute), 1971, No 87, pp 96-102 (from RZh-Mekhanika, No 10, Oct 71, Abstract No 10B334)

Translation: The paper presents the results of a theoretical study of nozzle control implemented on both stages of a turbine. The ratio of the areas at the outlets from the guide vane assemblies is used as the control parameter. Calculations show that as the degree of expansion of the gas in a stage increases, the optimum values of the control parameter decrease. For instance when the degree of expansion is $\pi_T^* = 0.6$, the optimum value of the control parameter is 1.1, while at $\pi_T^* = 1.0$, the optimum control parameter decreases to 0.8. The permissible ranges of variation in the control parameter ΔI are determined from the condition of a reduction in efficiency by no more than 0.5%: at a degree of expansion of $\pi_T^* = 1.0$, this range is 0.7-0.9, and at $\pi_T^* = 0.6$, it is 0.98-1.28. A. G. Plotkina.

1/1

USSR

UDC 691.325.65

ARTYUKH, YU. N., BAUMS, A. K., and ZAGURSKIY, V. YA., Institute of Electronics and Computer Technology, Academy of Sciences Latvian SSR

"General-Purpose Logic Element"

USSR Authors' Certificate No 309462, Cl. H 03 k 19/00, filed 3 Dec 69, published 7 Oct 71 (from RZh-Avtomatika, Telemekhanika i Vychislitel'naya Tekhnika, No 5, May 72, Abstract No 5B142P)

Translation: The authors propose a logic element for an amplifier shaping circuit that is a transistor stage with a TD connected to the emitter and a feedback shaping transistor in which the amplifier shaping circuit is connected via the current-controlling resistor to a bistable memory element and via a switching diode to a pulse signal source. The one setting inputs in the proposed element contain isolation diodes. A number of high-speed synchronous and asynchronous devices can be constructed on the basis of the proposed circuit, since its output can be loaded on any of the inputs (or set of inputs) of the logic element, including the gating input. The introduction of isolation diodes in the one setting input makes it possible to effect control action with any given signal source and permits switching at will of the logic element inputs. This expands the functional capabilities of the element. Three illustrations.

1/1

- 26 -

USSR

UDC 669.24.782:537.31

BAUM, B. A., GEL'D, P. V., and TYAGUNOV, G. V., Ural Polytechnical Institute, Physics Department

"Influence of Temperature on the Electrical Resistance of Lower Silicides of Nickel"

IVUZ, Tsvetnaya Metallurgiya, No 2, 1971, pp 53-57.

Abstract: Specimens for investigation were prepared by melting electrolytic high-purity nickel and monocrystalline silicon in a high-frequency induction furnace. Resistivity was measured by a contactless method in aluminum oxide (or zirconium oxide) crucibles in an atmosphere of helium. The results indicated that liquid alloys of nickel with silicon are characterized by heterogeneous interatomic bonds and complex near order structure, which changes with composition and may differ, depending on the heating and cooling conditions of the liquid alloy.

1/1

USSR

UDC 669.24.782:537.31

2
BAUM, B. A., GEL'D, P. V., and TYAGUNOV, G. V., Ural Polytechnical Institute, Physics Department

"Influence of Temperature on the Electrical Resistance of Lower Silicides of Nickel"

IVUZ, Tsvetnaya Metallurgiya, No 2, 1971, pp 53-57.

Abstract: Specimens for investigation were prepared by melting electrolytic high-purity nickel and monocrystalline silicon in a high-frequency induction furnace. Resistivity was measured by a contactless method in aluminum oxide (or zirconium oxide) crucibles in an atmosphere of helium. The results indicated that liquid alloys of nickel with silicon are characterized by heterogeneous interatomic bonds and complex near order structure, which changes with composition and may differ, depending on the heating and cooling conditions of the liquid alloy.

1/1

USSR

UDC 532.13,546.76

TYAGUNOV, G. V., BAUM, B. A., and GEL'D, P. V., Urals Polytechnic Institute
imeni S. N. Kirov

"Kinematic Viscosity of Liquid Alloys of Chromium With Carbon"

Tomsk, Izvestiya Vysskhik Uchebnykh Zavedeniy, Fizika, No 8(111), 1971,
pp 159-160

Abstract: A study was made of the variation with temperature and concentration of the viscosity and thermodynamic characteristics of the elementary viscous flow in liquid alloys of chromium with carbon. The temperature range was 1675-1925°. The plots of the ploytherms of kinematic viscosity of liquid alloys of chromium with carbon, isotherms of viscosity, change in isobaric-isothermal potential ΔZ , entropy ΔS , and energy of activation E of the viscous flow of chromium-carbon alloys showed that at 1850° the viscosity of alloys at first decreases with increased carbon content and then, beginning with 5.45 weight % C (the carbide $Cr_{23}C_6$) increases. At higher temperatures, due to the greater energy of thermal motion of particles, microinhomogeneity is less developed and its effect on viscosity with increase in carbon concentration is compensated by the rise of energies of interparticle interaction. Beginning with 5.5% C directed

1/2

USSR

TYAGUNOV, G. V., et al., Izvestiya Vysskh Uchebnykh Zavedeniy, Fizika, No 8(111), 1971, pp 159-160

Cr-C bonds become so well developed that the number of microdomains consisting only of "excess" chromium atoms is appreciably reduced and the melt becomes more homogeneous. In this case the rise in bonding energy is decisive; therefore, the viscosity and energy of activation of viscous flow are increased. The study thus indicates that in alloys of chromium with carbon the energy nonequivalence of the Cr-Cr and Cr-C bonds is maintained also in the domain of the liquid state up to temperatures of at least 1900°.

2/2

- 104 -

Physical Properties

USSR

UDC 669.14:669.04

BAUM, B. A., D'YAKONOVA, L. V., YERMANOVICH, N. A., TYAGUNOV, G. V., and KHASIN, G. A., Sverdlovsk, Zlatoust

"Physical Properties of Molten High-Alloy Steels and Special Alloys"

Moscow, Fizika i Khimiya Obrabotki Materialov, No 5, Sep-Oct 70, pp 43-48

Abstract: The article determines the kinematic viscosity, electrical resistivity, and density of specimens of more than 20 industrial brands of steels and alloys. The properties were measured after 5-15 minute isothermal holding periods, beginning with a temperature increase to 1700-1800° C and then followed by a temperature decrease down to crystallization of the melt. In some cases this measurement cycle was repeated (reheating and then cooling the specimen) without bringing the specimen to solidification. The specimens studied included NZhVI alloy (99.66 percent Fe), EI435, EI437 nickel-base alloys, alloys Kh28, Kh18N1OT, EI811, ShKh15, EI736, 12Kh2N4A, iron-base alloys U10, ShKh15, R18, 9Kh18 high-carbon steels, 4Kh9S2, E4, 1/3

USSR

BAUM, B. A., et al., Fizika i Khimiya Obrabotki Materialov, No 5, Sep-Oct 70, pp 43-48

and 30KhGSNA steels, and alloy 60. The effect of the chemical composition of the specimens, nonmetallic inclusions, and production method on the physical properties was considered.

The results indicate that the kinematic viscosity, electrical resistance, and density of molten steels and special alloys depend mainly on the chemical composition and production method. The phenomenon of hysteresis of properties is observed, indicating differences in the structure of a molten specimen during its heating and cooling. The magnitude of the hysteresis may serve as one of the characteristics of a given specimen along with data on its physical properties. The structure of melts before crystallization (composition and properties of microvolumes, coordination of the atoms in them, etc.) should be regarded as one of the metallurgical heredity factors capable of influencing a number of the service characteristics of the solid metal.

2/3

- 41 -

USSR

BAUM, B. A., et al., Fizika i Khimiya Obrabotki Materialov, No 5, Sep-Oct 70, pp 43-48

The authors thank P. V. GEL'D for his advice and interest in the work.

3/3

1/2 045

UNCLASSIFIED

PROCESSING DATE--13NOV7

TITLE--THERMOPHYSICAL AND THERMODYNAMIC CHARACTERISTICS OF MOLTEN ALLOYS
OF IRON WITH CHROMIUM -U-
AUTHOR--(03)-PAVARS, I.A., BAUM, B.A., GELD, D.V.

B

COUNTRY OF INFO--USSR

SOURCE--TEPLOFIZ. VYS. TEMP. 1970, 8(1), 72-6

DATE PUBLISHED--70

SUBJECT AREAS--MATERIALS

TOPIC TAGS--CHROMIUM ALLOY, HEAT OF FORMATION, ENTHALPY, ENTROPY, METAL
PHASE SYSTEM, PHASE ANALYSIS, LIQUID METAL, IRON ALLOY

CONTROL MARKING--NO RESTRICTIONS

DOCUMENT CLASS--UNCLASSIFIED

PROXY REEL/FRAME--1994/1938

STEP NO--UR/0294/70/008/001/0072/0076

CIRC ACCESSION NO--AP0115746

UNCLASSIFIED

2/2 045

UNCLASSIFIED

PROCESSING DATE--13NOV70

CIRC ACCESSION NO--AP0115746

ABSTRACT/EXTRACT--(U) GP-0- ABSTRACT. VAPOR PRESSURES OF MOLTEN ALLOYS OF FE WITH CR WERE DETD. AT 1600-1700DEGREES FOR VARIOUS FRACTIONS OF CR (N SUBCR EQUALS 0-0.62) BY THE LARGE DROP METHOD. INTEGRAL HEAT OF EVAPN., ACTIVITIES OF ALL COMPONENTS, INTEGRAL FORMATION ENTHALPY, ENTROPY, AND ISOBARIC POTENTIAL OF MOLTEN ALLOYS WERE CALCD. THE SLIGHT DEVIATIONS FROM IDEALITY CAN BE EXPLAINED BY STRONG DONOR ACCEPTOR INTERACTIONS OF FE AND CR ATOMS IN A LIQ. PHASE. FACILITY: URAL. POLITEKH. INST. IM. KIROVA, SVERDLOVSK, USSR.

UNCLASSIFIED

1/2 017 UNCLASSIFIED PROCESSING DATE--16OCT70
TITLE--SOLUBILITY OF HYDROGEN IN SILICON -U-
AUTHOR-(03)-KOSTINA, T.K., BAUM, B.A., KUROCHKIN, K.T.
COUNTRY OF INFO--USSR
SOURCE--IZV. AKAD. NAUK SSSR, NEORG. MATER. 1970, 6(1), 117
DATE PUBLISHED-----70
SUBJECT AREAS--CHEMISTRY, MATERIALS
TOPIC TAGS--HYDROGEN, SOLUBILITY, SILICON, GAS CONTAINING METAL, METAL
CONTAINING GAS
CONTROL MARKING--NO RESTRICTIONS
DOCUMENT CLASS--UNCLASSIFIED
PROXY REEL/FRAME--1996/0844 STEP NO--UR/0363/70/006/001/0117/0117
CIRC ACCESSION NO--AP0118020
UNCLASSIFIED

2/2 017

UNCLASSIFIED

PROCESSING DATE--16OCT70

CIRC ACCESSION NO--AP0118020

ABSTRACT/EXTRACT--(U) GP-0- ABSTRACT. THE SOLY. OF HYDROGEN IN SI WAS
DETD. BY USING THE HOT VOL. METHOD. THE H CONTENT IN SI AT THE M.P. AND
AT 28 TORR IS 1.37 TIMES 10 PRIME NEGATIVE3 AT. PERCENT. IT WAS NOT
POSSIBLE TO OBTAIN AN UNEQUIVOCAL ANSWER AS TO WHETHER THE SQUARE ROOT
LAW IS FULFILLED. AT GREATER THAN 1200DEGREES, THE SOLY. DOES NOT
EXCEED 0.099 TIMES 10 PRIME NEGATIVE2 AT. PERCENT (0.5 CM PRIME3-100 G).
FACILITY: URAL. POLITEKH. INST. IM. KIROVA, SVERDLOVSK, USSR.

UNCLASSIFIED

Physical Properties

USSR

UDC 669.168

GEL'D, P. V., BAUM, B. A., and PETRUSHEVSKIY, M. S.

Rasplavy Ferrosplavnogo Proizvodstva (Melts of the Ferro-Alloy Industry),
Moscow, Metallurgiya, 1973, 288 pp

Translation of Annotation: Alloys of 3d transitional metals with silicon and carbon play an important role in metallurgy. Among these alloys are the following: ferrochromium, ferromanganese, ferrosilicon, silicochromium, silicomanganese, ferrosilicochromium, ferrosilicomanganese, and many other ferroalloys and master alloys. Steels with special properties (heat-resistant, wear-resistant, and others) are also related to these groups of alloys. These alloys can be refined further from impurities and used at high temperatures in a liquid state. Therefore, study of the metallurgical problems of these alloys in a liquid state is of prime importance. Since these alloys are produced in electric furnaces, it is necessary to know their electrical resistance properties in order to calculate the furnace parameters and devices for electromagnetic mixing and transportation of metal, to define their heat balance, etc. The basic reactions in these alloys take place at the interface of liquid metal and gaseous or slag phases. Therefore, the kinetics of these reactions depends to a great extent on the surface concentration of reacting substances which is calculated from the surface tension of liquid alloys. The mass transfer

1/7

USSR

GEL'D, P. V., et al, Rasplavy Ferrosplavnogo Proizvodstva (Melts of the Ferro-Alloy Industry), Moscow, Metallurgiya, 1973, 288 pp

rate is determined very often from viscosity and from the melt density in the case of the sinking of the drop. These properties regulate many characteristics of metallurgical processes, such as enlargement of particles, flotation of non-metallic inclusions, and many others. Knowledge regarding actual concentration and solubility of hydrogen in ferro-alloys, their emissivity, and other properties is also of importance. The nature of the interparticle interactions in melts is one of the fundamental characteristics of these alloys. All of this information is necessary for establishing the molecular kinetics nature of the alloys, the mechanisms of processes during their preparation, the crystallization kinetics of melts, and the complex genetic interactions taking place between solid and liquid phases in order to be able to control the structure of ingots. Thus, information regarding the interparticle interactions and structure of melts is necessary for defining the micro- and macroscopic characteristics of metallurgical processes, and to produce a better quality product. The main aims of the authors in writing this book were:

- (1) Compilation of data regarding the properties of the mentioned alloys;
- (2) Discussing the features of the interparticle interactions and structure of these alloys, using for this purpose physicochemical analysis methods, as well

2/7

USSR

GEL'D, P. V., et al, Rasplavy Ferrosplavnogo Proizvodstva (Melts of the Ferro-Alloy Industry), Moscow, Metallurgiya, 1973, 288 pp

as utilizing information borrowed from related subjects (the theory of chemical bonds, physics of metals, molecular physics, and others); (3) Evaluation of methods and computational results regarding the thermodynamic characteristics of silicon and carbon melts.

TABLE OF CONTENTS

Introduction	3
Chapter 1. Liquid State of Metals	
Development of the Theory of Liquids	5
Models of Liquids	8
The Nature of Thermal Motion of Melt Particles	11
The Role of Interatomic Interaction in the Formation of Structure and Properties of Liquid Metals	14
Covalent and Metal Bonds	16
Structural and Physicochemical Properties of Liquid Metal Alloys	18
Properties and Structure of Liquid Solutions of 3d Transitional Metals	29

3/7

USSR

GEL'D, P. V., et al, Rasplavy Ferrosplavnogo Proizvodstva (Melts of the Ferro-Alloy Industry), Moscow, Metallurgiya, 1973, 288 pp

Chapter 2. Properties and Structure of Silicon Melts

Structure of Liquid and Amorphous Silicides According to X-ray and Electronographic Studies	51
Results of X-ray Studies of Molten Iron Silicides	60
Results of Electronographic Studies of Amorphous Phases of Silicon, Chromium, and its Silicides	72
Properties and Structure of Liquid Chromium Alloys with Silicon	80
Electrical Conductivity	80
Viscosity	85
Density and Surface Tension	89
Solubility of Hydrogen	93
Properties and Structure of Mn - Si Melts	101
Electrical Resistance	103
Viscosity	106
Density and Surface Tension	109
Hydrogen Solubility	113

4/7

USSR

GEL'D, P. V., et al, Rasplavy Ferrosplavnogo Proizvodstva (Melts of the Ferro-Alloy Industry), Moscow, Metallurgiya, 1973, 288 pp

Properties and Structure of Fe - Si Melts	115
Electrical Resistance	116
Viscosity	119
Density and Surface Tension	122
Solubility of Hydrogen and Deuterium	126
Emissivity	130
Properties and Structure of Co-Si and Ni-Si Melts and Certain Polycomponent Systems	136
Cobalt Alloys with Silicon	136
Nickel Alloys with Silicon	141
Polycomponent Silicon Melts	146
Chapter 3. Properties and Structure of Carbonic Melts	
Liquid Alloys of Chromium and Iron with Carbon	149
Electrical Resistance	149
Viscosity	152
Density and Surface Tension	160
Liquid Alloys of Mn - C and Mn - Fe - C Systems	166
Electrical Resistance	167

5/7

USSR

GEL'D, P. V., et al, Rasplavy Ferrosplavnogo Proizvodstva (Melts of the Ferro-Alloy Industry), Moscow, Metallurgiya, 1973, 288 pp

Viscosity	171
Density and Surface Tension	175
Chapter 4. Thermodynamics of Liquid Ferro-Alloys	
Thermodynamic Characteristics of Alloys of 3d Transitional Metals with Silicon and Carbon	177
Properties of Me - Si Melts	177
Properties of Me - C Melts	191
Computing Methods of Thermodynamic Characteristics of Melts	211
Ideal and Nonideal Solutions	212
Regular Solutions	216
Subregular Solutions	217
Short-Range Order in Liquid Alloys	219
Symmetrical Variant of the Quasi-chemical Theory	220
Asymmetrical Variant of the Quasi-chemical Theory	223
Taking Into Account the Temperature Dependence of the Energy Interaction	225
The Cluster Theory of Solutions	226
Considering the Concentrational Dependence of the Energy of Interatomic Interactions	227

6/7

- 33 -

USSR

GEL'D, P. V., et al, Rasplavy Ferrosplavnogo Proizvodstva (Melts of the Ferro-Alloy Industry), Moscow, Metallurgiya, 1973, 288 pp

Computing the Thermodynamic Characteristics of Me - Si and Me - C Melts	233
Binary Liquid Me - Si Alloys	233
Liquid Fe - Si Alloys	233
Co - Si and Ni - Si Alloys	241
Carbon Solubility in Liquid Metal Alloys and in Alloys of Metal with Silicon	246
Solubility of Carbon in Metal Melts with Ideal Ordering	247
Solubility of Carbon in Liquid Alloys of Iron and Manganese with Silicon	250
Solubility of Carbon in Fe-Mn-Si-C and Fe-Cr-Si-C Melts	255
Solubility of Hydrogen in Liquid Alloys of 3d Transitional Metals with Silicon	258
Conclusion	268
Bibliography	270

7/7

USSR

BAUM, I. V.; GORBATENKO, M. V.; ROMANOV, Yu. A. (Lebedev Physics Institute,
USSR Academy of Sciences)

"Dynamics of Matrix Space Taking into Account Third-Order Terms in the Lagrangian"

Moscow, Teoreticheskaya i Matematicheskaya Fizika; March, 1971; pp 338-47

ABSTRACT: The general properties of the dynamics of matrix space, formulated in two previous issues of the same journal (January, 1969; p 222; March, 1970; p 183) by Gorbatenko and Romanov, are used in order to derive the Lagrangian, taking into account the second- as well as third-order terms in the expression for the magnitude of the deviation from the vacuum state. It is proven that all cubic terms in the expressions for physical quantities can be eliminated by means of a suitable invariant transformation. This corresponds to the absence of terms proportional to ψ^3 in the similar expressions of the spinor theory.

The article includes 39 equations. There are two bibliographic references.
1/1

- 99 -

Coatings

USSR

UDC 621.74.015:621.744.37

KUMAININ, I. B., BAUMAN, B. V., OREKHOV, A. I., ISAYEVA, T. A., SMOL'KIN, A. A., and ZOTOVA, N. G., Moscow Institute of Steel and Alloys"

Ceramic Antiscorching Coatings for Steel Castings"

Moscow, Izvestiya Vysshikh Uchebnykh Zavedeniy, Chernaya Metallurgiya, No 7, 1973, pp 53-56

Abstract: Antiscorching coatings with ceramic type bonding agents were developed on the base of metallophosphates. Starting materials for the production were orthophosphoric acid H_3PO_4 , aluminum hydroxide $Al(OH)_3$, and chromium acid Cr_2O_3 . The coatings possess high refractoriness and resistance, high thermal stability, and chemical inertia in the working temperature interval. They also have high technological qualities, as good covering power, and high sedimentation stability. The coatings do not contain scarce materials and are not expensive. Results of industrial tests are presented of antiscorching coatings on carbon steel and alloy steels. Comparative results of petrographic analyses of antiscorching coatings are discussed by reference to microsections of the mold and of metal-mold

1/2

USSR

KUMANIN, I. B., et al., Izvestiya Vysshikh Uchebnykh Zavedeniy, Chernaya Metallurgiya, No 7, 1973, pp 53-56

and metal-coating contact zones. Three figures, six bibliographic references.

2/2

- 4 -

USSR

UDC 621.762.002.5

GASUL', M. Yu., STRAUTMANIS, A. A., BAUMANIS, A. A.

"Batcher"

USSR Author's Certificate No 270206, Filed 28 Oct 68, Published 18 Aug 70
(from RZh-Metallurgiya, No 4, Apr 71, Abstract 4G472P)

Translation: A batcher used in the extrusion process containing a hopper and a powder feed mechanism is introduced. To decrease powder losses and increase batching accuracy, the batcher is equipped with a labyrinth attachment whose walls and knives are spring-loaded.

1/1

USSR

UDC: 658.562.012.7

BALMBERG, I. D., KRUASHVILI, Z Ye., FAYN, V. B.

"Method of Centralized Testing of Several Objects"

USSR Author's Certificate Number 306466, filed 19/02/69, published 21/07/71 (translated from Referativnyy Zhurnal Avtomatika, Telemekhanika i Vychislitel'naya Tekhnika, No 3, 1972, Abstract No 3 A372 P)

Translation: A method is suggested for centralized testing of several objects by converting the parameters being tested with respect to their deviation from fixed limits into sequences of irregularly distributed pulses not coinciding with each other in time. In order to increase the effectiveness of the central testing device, the sequences produced are compared with the cycling sequence, and the object whose pulse sequence contains the pulse which first coincides with the cycling sequence pulse is tested.

1/1

- 25 -

USSR

UDC: 621.317.7-5(02)

BAUMGART, V. F.

"Automating the Inspection of Radio Receivers"

Avtomatizatsiya kontrolya radiopriyemnikov (cf. English above), Moscow, "Svyaz", 1970, 84 pp, ill. 29 k. (from RZh-Radiotekhnika, No 12, Dec 70, Abstract No 12A295)

Translation: The book takes up the basic functional modules and devices of automatic inspection systems for monitoring and measuring the parameters of radio receivers. A number of schematic circuits are given of devices for shaping input signals and automatically measuring the electrical parameters of the receiver being inspected. Systems for automatically monitoring and measuring the basic parameters of radio receivers are described. The book is written for engineering and technical workers occupied with the automation of production processes. It may be useful to students majoring in radio engineering. Forty illustrations, two tables, bibliography of thirty-two titles. Resumé.

1/1

USSR

UDC: 621.375.826+621.059.64

SIGEL, R., WITKOWSKI, S., BAUMHACKER, H., BÜCHL, K., ELDMANN, K.,
HORA, H., MENNICKE, H., MÜLSER, P., PFIRSCH, D., SALZMANN, H.

"Survey of Studies of Laser-Produced Plasmas at the Max Planck
Institute of Plasma Physics in Garching, West Germany"

Moscow, Kvantovaya Elektronika, Sbornik Statey, No 2(8), 1972,
pp 37-44

Abstract: The paper is a survey of experimental and theoretical
research on laser-produced plasmas done at the Max Planck Insti-
tute of Plasma Physics in Garching. Experiments are described
on heating of a plasma by emission from a neodymium laser with
energy of 50 J and pulse duration of approximately 30 ns. The
plasma temperature was measured by a filter method; the time of
flight and average kinetic energy of the ions were measured by
probes. A laser with a single pulse lasting a few picoseconds
is described. The results of theoretical studies done on com-
puters are presented. [The article is a brief version of a paper
presented to the editors by the organizational committee of the

1/2

USSR

SIGEL, R. et al., Kvantovaya Elektronika, Sbornik Statey, No 2(8), 1972, pp 37-44

International Conference on Laser-Produced Plasmas, Moscow, 1970. Translation by A. S. Shikanov.] Nine illustrations, bibliography of seven titles.

2/2

- 40 -

BAURIN, I. P.

AA0052663

UR 0482

8

Soviet Inventions Illustrated, Section III Mechanical and General, Derwent, 2-71

244184 TIMBER ROLLING MECHANISM comprises a chassis and a grab with a compound pulley for covering the grab. There are also log grabs for tractors and hoists which are used for rolling timber into water. In order to retain efficiently the bundles of timber during the movement of the mechanism over uneven surfaces, the movable blocks (4) of the pulley system are fixed in the lower jaw (2) of the grab, whilst the end of the rod of the pulley system is fixed on the upper jaw (3) of the grab which is connected to the chassis by a rod (8) regulated according to length. By means of the compound pulleys of the grab the bundle of timber is compressed by the jaws of the mechanism and is retained by them during transportation. The mechanism can be coupled to any hauling tractor.

29.12.67. as 1206439/29-33, LESHKEVICH, A.I. et al. Timber Ind. Mech. & Energetics Res. & Design Inst. (8.10.69) Bul. 17/14.5.69. Class 81e, Int. Cl. B 65g.

18

1/3

19821411

AA0052663

Leshkevich, A.I.; Levitskiy, Ya.Ye.; Reutov, Yu.M.; Baurin, I.P.;
Korolev, V.Ye.; Tsentral'nyy Nauchno-Issledovatel'skiy i Proyektno-
Konstruktorskiy Institut Mekhanizatsiy i Energetiki Lesnoy Promyshlennosti

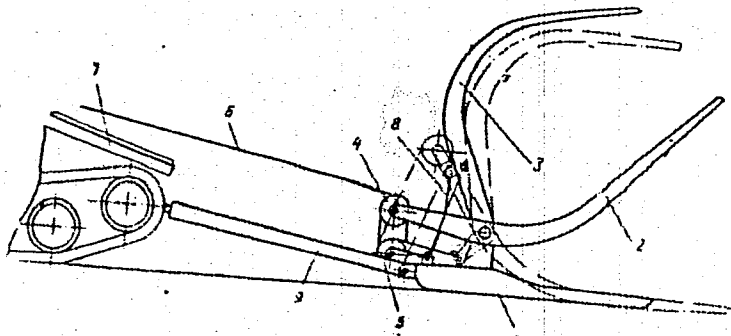

2/2

19821412

USSR

UDC 518:517.944/.947

BAUTIN, A. V., KONOVALOV, A. P., ISAYEV, Yu. V., and SLIVA, A. V.

"Problems in Constructing Algorithms for Solving Equations in Mathematical Physics as Applied to Electrical Engineering Problems"

Moscow, Primeneniye vychisl. tekhn. v elektrotekhn. prom-sti -- Sbornik (Application of Computers in the Electrotechnical Industry -- Collection of Works), 1971, pp 347-353 (from Referativnyy Zhurnal -- Matematika, No 7, July 71, Abstract No 7B957, by I. Shelikhova)

Translation: Problems associated with constructing algorithms for solving nonlinear equations of the elliptical and parabolic types as applied to electrotechnical problems are examined. An algorithm is presented for solving the first boundary value problem that arises when calculating the nonstationary mode of a thermoelectric transformer using a locally one-dimensional problem in conjunction with the method of successive approximations. Sufficient conditions for the convergence of the iterative process are derived.

1/1

USSR

UDC: 624.07:534.1

BAUYER, V. O., SHORR, B. F.

"Effect Which the Detuning of Blade Frequencies has on Resonance Oscillations"

V sb. Prochnost' i dinamika aviats. dvigateley. Vyp. 6 (Strength and Dynamics of Aircraft Engines--collection of works, No 6), Moscow, "Mashinostroyeniye", 1971, pp 75-98 (from RZh-Mekhanika, No 7, Jul 71, Abstract No 7V231)

Translation: Based on an example of a simplified model of a wheel with unidentical blades, this paper examines the effect of frequency detuning on the distribution and level of stresses in resonance oscillations. It is shown by a series of digital computer calculations of different ways of arranging blades with different frequencies that frequency detuning leads to an increase in the maximum resonance stresses as compared with the stresses in exactly tuned blades, and also to scatter of the maximum stress values in individual blades. Authors' abstract.

1/1

- 155 -

USSR

UDC: 531.55:521.1

BAUZE, V. R. E., VITYUTSKIKH, V. T., ZAVADSKIY, V. M., NIKULIN, A. M., PRONIN, Yu. S.

"On the Problem of Optimum Control of Angular Motions of a Rotating System of the Dumbbell Type"

Tr. 4-kh chteniy, posvyashch. razrabotke nauchn. naslediya i razvitiyu idey K. E. Tsiolkovskogo, 1969, Sekts. "Mekh. kosmich. poleta" (Works of the Fourth Lecture Series Dedicated to Elaboration of the Scientific Heritage and Development of the Ideas of K. E. Tsiolkovskiy, 1969, Section on the Mechanics of Space Flight), Moscow, 1970, pp 99-113 (from RZh-Mekhanika, No 4, Apr 71, Abstract No 4A112)

Translation: The authors consider the motion of a rotating dumbbell-shaped space station subjected to small controlling moments whose time dependence is predetermined. As a result of integrating the system of equations of motion, which is possible after a considerable number of approximating simplifications, the problem of variation in the plane of rotation is solved. S. Ya. Stepanov.

1/1

- 15 -

USSR

UDC: 621.397.332

BAUZHIS, A. V., GOSHTAUTAS, G. P., ZHLABIS, S. B.

"An Output Line-Scanning Transformer"

USSR Author's Certificate No 278734, filed 5 May 69, published 3 Dec 70
(from RZh-Radiotekhnika, No 6, Jun 71, Abstract No 6G167 P)

Translation: An output line-scanning transformer is proposed which contains a II-shaped ferrite core with potted anode and high-voltage windings placed on opposite legs of the core. To reduce electric field strength between the windings, they are interconnected by a bridge of insulating material.

1/1

- 154 -

1/2 026 UNCLASSIFIED PROCESSING DATE--23OCT70
TITLE--EXPERIMENTAL DIABETES MELLITUS INDUCED BY
5, (N, ACETAMINOPHENYLAZO), 8, OXYQUINOLINE AND ITS PREVENTION -U-
AUTHOR--(02)-LAZARIS, A.YA., BAVELSKIY, Z.YE.

COUNTRY OF INFO--USSR

SOURCE--PATOLOGICHESKAYA FIZIOLOGIYA I EKSPERIMENTAL'NAYA TERAPIYA, 1970,
VOL 14, NR 2, PP 44-48
DATE PUBLISHED-----70

SUBJECT AREAS--BIOLOGICAL AND MEDICAL SCIENCES

TOPIC TAGS--DIABETES MELLITUS, AMINE DERIVATIVE, BENZENE DERIVATIVE,
QUINOLINE, PANCREAS, LESION, PROPHYLAXIS, ORGANIC SULFUR COMPOUND,
CARBAMATE

CONTROL MARKING--NO RESTRICTIONS

DOCUMENT CLASS--UNCLASSIFIED
PROXY REEL/FRAME--1988/0145

STEP NO--UR/0396/70/014/002/0044/0048

CIRC ACCESSION NO--AP0105231

UNCLASSIFIED

2/2 026

UNCLASSIFIED

PROCESSING DATE--230CF70

CIRC ACCESSION NO--AP0105231

ABSTRACT/EXTRACT--(U) GP-0- ABSTRACT. INTRAVENOUS INJECTION OF 15 TO 50 MG-KG OF BODY WEIGHT OF 5, (N, ACETOAMINOPHENYLAZO), 8, OXYQUINOLINE PRODUCE SEVERE DIABETES IN RABBITS. THE DISEASE DEVELOPED AS A RESULT OF PROFOUND DESTRUCTIVE LESIONS IN THE ISLANDS OF LANGERHANS OF THE PANCREAS. APPARENTLY THE MECHANISM OF DIABETOGENIC EFFECT OF THE MENTIONED COMPOUND IS BROUGHT TO THE BLOCK OF ZINC IN THE CELLS OF THE ISLANDS WITH THEIR SUBSEQUENT DESTRUCTION AND DEVELOPMENT OF PRIMARY INSULIN DEFICIENCY. DEVELOPMENT OF DIABETES CAN BE COMPLETELY PREVENTED BY PRELIMINARY (30 MINUTES PREVIOUSLY) ADMINISTRATION OF 500 TO 1,000 MG-KG OF DIETHYLDITHIOCARBAMATE OF SODIUM. FACILITY: KAFEDRA PATOLOGICHESKOY FIZIOLOGII KARAGANDINSKOGO MEDITSINSKOGO INSTITUTA.

UNCLASSIFIED

172 033 UNCLASSIFIED PROCESSING DATE--04DEC70
TITLE--CARBONIZATION OF RESOL TYPE PHENOL FORMALDEHYDE RESINS -U-

AUTHOR--(05)--BERLIN, A.A., FIALKOV, A.S., TSVELIKHOVSKIY, G.I., ASEYEVA,
R.M., DAYER, A.I.
COUNTRY OF INFO--USSR

SOURCE--PLAST. MASSY 1970, (6): 44-B

DATE PUBLISHED-----70

SUBJECT AREAS--CHEMISTRY, MATERIALS

TOPIC TAGS--PHENOL FORMALDEHYDE RESIN, PYROLYSIS, X RAY STUDY, IR
SPECTRUM, METHYLENE, DEHYDROGENATION, GAS CHROMATOGRAPHY, MASS
SPECTROSCOPY, CONJUGATE BOND SYSTEM, POLYMER STRUCTURE

CONTROL MARKING--NO RESTRICTIONS

DOCUMENT CLASS--UNCLASSIFIED
PROXY REEL/FRADE--3007/0732

STEP NO--UR/0191/70/000/006/0044/0048

IRC ACCESSION NO--AP0136171

UNCLASSIFIED

2/2 033

UNCLASSIFIED

PROCESSING DATE--04DEC7

IR# ACCESSION NO--AF0136171

ABSTRACT/EXTRACT--(U) GP-0- ABSTRACT. SAMPLES OF BAKELITE (I) CONTG. VARIOUS AMTS. OF PHOH WERE PREPD. BY THE PURIFICATION OF COM. I. I WAS THEN PYROLYZED IN VACUUM OR IN AR AT TEMPS. LESS THAN OR EQUAL TO 1000DEGREES. ANAL. OF DTA DATA AND S RAY AND IR SPECTRA SHOW THAT THE MAIN REACTIONS WERE BREAKING CH SUB2 BRIDGES, DEHYDROGENATION, AND FREE RADICAL REACTIONS INVOLVING QUINONOID STRUCTURES. GAS CHROMATOG. AND MASS SPECTROSCOPY SHOWED THAT THE MAIN DECOMP. PRODUCTS WERE PHOH, CRESOL, BENZENE, H SUB2, CH SUB4, CO, CO SUB2, AND H SUB2 O. THE CARBONIZED RESIDUE OBTAINED AT 900DEGREES HAD AN UNORGANIZED STRUCTURE. INCREASING THE PYROLYSIS TEMP. INCREASED THE NO. OF CONJUGATED STRUCTURES AND ORDERING. THE SAMPLES WITH LOWER INITIAL PHOH CONTENTS GAVE DENSER PYROLYZED STRUCTURES.

1/2 012 UNCLASSIFIED PROCESSING DATE--2306170
TITLE--EFFECT OF HYDROLYSIS AND NEUTRALIZATION CONDITIONS ON THE EXTENT OF
DECOMPOSITION OF HIGHER FATTY ALCOHOL SULFATES -U-
AUTHOR-(02)-PERISTYY, V.A., BAVIKA, V.I.
COUNTRY OF INFO--USSR
SOURCE--NEFTEPERERAB. NEFTEKHIM. MOSCOW 1970, (2), 36-8
DATE PUBLISHED-----70
SUBJECT AREAS--CHEMISTRY, MATERIALS
TOPIC TAGS--HYDROLYSIS, SULFONATION, SULFATE, DETERGENT, CHEMICAL
DECOMPOSITION, THERMAL STABILITY
CONTROL MARKING--NO RESTRICTIONS
DOCUMENT CLASS--UNCLASSIFIED
PROXY REEL/FRAE--1997/0569 STEP NO--UR/0318/70/000/002/0036/0038
CIRC ACCESSION NO--AP0119487
UNCLASSIFIED

2/2 012

UNCLASSIFIED

PROCESSING DATE--23OCT70

CIRC ACCESSION NO--AP0119487

ABSTRACT/EXTRACT--(U) GP-0- ABSTRACT. SULFO ESTERS, OBTAINED BY SULFONATING C SUB10-18 FATTY ALCS. WITH H SUB2 SO SUB4 OR HSO SUB3 CL, WERE HYDROLYZED WITH MEASURED AMTS. OF H SUB2 O AND THE ACIDITY WAS RAPIDLY DETD. THE HYDROLYSIS DEGREE INCREASED WITH THE INCREASE OF THE CONC. OF ESTERS, TEMP., AND ACIDITY. THE SULFO ESTERS HAD RATHER GOOD STABILITY AT 30DEGREES, HENCE COULD BE USED AS DETERGENTS AT MODERATE TEMP. THE DURATION OF THE PROCESS WAS REDUCED BY CARRYING OUT THE NEUTRALIZATION AT HIGHER TEMP. THE CONC. OF ALKYL SULFATES IN THE PASTE COULD BE INCREASED BY USING MORE CONCD. ALKALI, PROVIDING INTENSIVE MIXING, AND MAINTAINING AN ALK. MEDIUM. THE PRODUCTIVITY OF THE INSTALLATION FOR OBTAINING ALKYL SULFATES COULD BE THUS INCREASED.

UNCLASSIFIED

1/2 010 UNCLASSIFIED PROCESSING DATE--18NOV70
TITLE--RESISTANCE TO SAPONIFICATION OF SULFOSUCCINIC ACID MONOESTER SALTS
IN THE PRESENCE OF MAGNESIUM IONS -U-
AUTHOR-(04)-REZNIKOV, I.G., BAVIKA, V.I., BOGACHEVA, S.F., POBORTSEVA,
L.A.
CCOUNTRY OF INFO--USSR
SOURCE--MASTO-ZHIR. PROM. 1970, 36(1), 20-3 **B**
DATE PUBLISHED-----70
SUBJECT AREAS--CHEMISTRY, MATERIALS
TOPIC TAGS--SAPONIFICATION, ORGANIC SULFUR COMPOUND, SUCCINIC ACID,
MAGNESIUM SULFATE, CALCIUM COMPOUND, COPPER COMPOUND, DETERGENT
CENTRCL MARKING--NO RESTRICTIONS
DOCUMENT CLASS--UNCLASSIFIED
PROXY REEL/FRAE--1989/0518 STEP NO--UR/9085/70/036/001/0020/0023
CIRC ACCESSION NO--AP0107123
UNCLASSIFIED

2/2

010

UNCLASSIFIED

PROCESSING DATE—13NOV70

CIRC ACCESSION NO--AP0107123

ABSTRACT/EXTRACT--(U) GP-0- ABSTRACT. RESISTANCE TO SAPON. OF SULFOSUCCINIC ACID MONOESTERS IN AN ALK. MEDIUM IS GREATLY INCREASED BY ADDN. OF MG, CA, OR CU SALTS. IN COMPNS. CONTG. 12.5PERCENT ACTIVE SUBSTANCE PARENTHESIS DI-NA SALT OF MONOALKYL SUCCINATE (ALKYL DERIVED FROM SPERMACE TI ALC.) (I) PARENTHESIS, 20PERCENT NA POLYPHOSPHATE, 1PERCENT NA SILICATE, 12-15PERCENT NA SUB2 SO SUB4, REST H SUB2 O, A PART OF NA SUB2 SO SUB4 WAS REPLACED BY 4-8PERCENT MGSO SUB4. SAPON. OF I IN SUCH A DETERGENT IN AN ALK. MEDIUM WAS 80-6PERCENT LESS THAN A DETERGENT NOT CONTG. MGSO SUB4. CA AND CU SALTS HAD A SIMILAR ACTION. WASHING EXPTS. WITH I ALONE AND WITH 8PERCENT MGSO SUB4 HAD 122 AND 130PERCENT, RESP., OF THE DETERGENT EFFICIENCY OF NA LAURYL SULFATE.

UNCLASSIFIED

USSR

UDC 539.67

ABUZOVA, E. A., BAYILYUK, V. S., and KHANDROS, I. G., Institute of Metal Physics, Academy of Sciences USSR

"Study of the Change in Internal Friction in Cu - Al - Ni Alloys Over the Temperature Range of the Formation of Elastic Martensite Crystals"

Kiev, Metallofizika, No 32, 1970, pp 100-104

Translation: The existence of phase equilibrium in martensite transformation in the Cu - Al - Ni alloy gives reason to believe that an increased value of internal friction should be observed in a two-phase region. Internal friction in the Cu - Al - Ni alloy with a martensite point of about 60° over the temperature range 120 to 160° C was studied by the torsional vibration method ($\dot{\gamma} = 1$ cps). It was shown that stable peaks of internal friction are observed over the temperature range of direct and inverse martensite transformation.

The maximum value of internal friction on the curves obtained corresponds to approximately 50% of the transformed phase. An increase in the deformation amplitude leads to an increase in internal friction over the temperature range of the $\beta_1 \rightarrow \gamma'$ transformation. Bibliography: 6 entries, 5 illustrations.

1/1

- 64 -

BAVRO, G.V.

JPRS #58459
13 MAR 73

- 1 -

IT - USSR - C

PRINCIPLES OF STANDARDIZING THE MICROCLIMATE OF INDIVIDUAL GAS-DEFENSE DEVICES
Article by Professor S. M. Korotkiy, Candidate of Biological Sciences G.V. Maslov, Doctor of Med. S. R. Ibragimov, Y. K. Kozlov, Candidate of Medical Sciences
Institute of Individual Gas-Defense Devices, Moscow, GELVODVA I Sankharin
Moscow, May 1, 1972, submitted to press 6 April 1972, pp 47-59

UDC: 614.895.5:613.481

JPRS 58459
13 March 1973

In ensuring safe working conditions at enterprises of the chemical, mining, petroleum, steel, and other branches of industry, as well as in the exploration of unpopulated areas and outer space an important role is played by individual gas-defense devices.

This report will examine questions concerning the setting of norms for parameters of the space under the airtight hood with assurance of thermal homogeneity of the organism. The urgency of these questions is confirmed by the fact that one of the main factors leading to a decline in working ability and a decrease in the duration of work in individual gas-defense devices consists of a change in heat exchange conditions between the organism and the surrounding medium.

On the basis of our own data contained in literature (I. S. Kandrton, et al.; V. I. Ketschani S. K. Gorodinskiy, et al., 1969, 1970) in the setting of norms for microclimatic parameters it appears to be justified to make to a certain degree a conditional division of functional states of the organism into optimal, permissible, and maximal. The microclimatic conditions in the space under the hood can also be divided into three zones corresponding to these states.

Optimal microclimatic conditions are considered to be those which ensure the preservation of the thermal balance without a pronounced straining of physiological thermoregulation mechanisms (Table 1). These conditions presuppose the absence of an influx of heat from the outside with optimal structure of heat convection layers at air velocity 1.5-2.0 m/sec (V. K. Vitevi P. I. Kolesnikov), the speed of air movement is considered to be equal to 0.2-0.3 meters/second, inasmuch as even in suits with forced ventilation as a rule it does not exceed these values. In an optimal microclimate of passive devices for individual protection the duration of their wear is determined not by the thermal state of the organism, but by

Table 1
Parameters of the Microclimate Under the Suit and Functional Shifts in the Organism Conditioned by It

(1) Микроклиматические условия и функциональные состояния организма при выполнении различных видов работ и характерных физических нагрузках	(2) Одежда				(3) Одежда				(4) Одежда			
	(5) Температура воздуха	(6) Влажность воздуха	(7) Скорость движения воздуха	(8) Давление	(5) Температура воздуха	(6) Влажность воздуха	(7) Скорость движения воздуха	(8) Давление	(5) Температура воздуха	(6) Влажность воздуха	(7) Скорость движения воздуха	(8) Давление
(9) Средняя температура (градусов)	37,7-37,8	37,4-37,6	37,9-38,4	36,6-37,2	35,0	37,8	37,6	37,0	35,8	38,4	38,2	
(10) Средняя температура тела (в градусах)	35,4-35,7	35,6-35,9	35,8-39,0	33,6-36,2	37,0	37,3	37,2	38,1	37,0	37,9	37,9	
(11) Коэффициент теплопроводности (ккал/град.см.мин.)			29-31									
(12) Частота сердечных сокращений (ударов в минуту)	130-140	110-112	91-110	70-75	70-75	100	100	100	100	100	100	
(13) Частота дыхания (в литрах)	250-300	150-200	100-150	30-70	30-40	30	30	100	20-25	30	30	
(14) Температура воздуха в подшлемном пространстве		15-27	21-31	27-33	30-34	30	35	40	30-31	37	41	50
Влажность		44-55	20-27	25-31	30-35	37	38	38	30-31	35	41	48
Скорость движения воздуха		13-23	10-27	20-29	10-20	20	20	20	20-29	33	33	33

- Keys
- | | |
|---|---|
| 1. Microclimatic conditions and functional states of the organism | 9. Rectal temperature (in degrees) |
| 2. Optimal | 10. Average body temperature (in degrees) |
| 3. Permissible | 11. Heat content (in kcal/kg) |
| 4. Maximal | 12. Rate of heart contractions (beats per minute) |
| 5. Heavy work | 13. Generation of moisture (grams/hour) |
| 6. Work of average intensity | 14. Temperature of air under suit with humidity of: |
| 7. Light work | 15. 0% to |
| 8. Rest | |

Note: Generation of heat in the performance of heavy work is 4-8,5 kcal/min., work of average intensity -- 3,5-6 kcal/min., light work -- 2-3,5 kcal/min., and in the state of rest -- 1,3-1,5 kcal/min.

1.1.1. The above rate of development depends on the nature and character of work, the production situation and so on. Maintenance of an optimal microclimate in individual environments, as a rule, requires the utilization of heat with the aid of artificial heat regulating systems. The use of liquid cooled suits appears to be the most effective from a physiological-hygiene viewpoint and most promising with regard to practical realization (Alifirova and Mikhlin; Bonard and Sverczak; Bannetov; G. H. Korotinskiy, et al., 1970). Liquid cooled suits ensure the elimination of heat primarily by the conduction method, that is they are used the basic means subject to normalization, consist of the parameters of the heat carrier flowing along tubes in contact with the body of the suit. Inasmuch as with the conductive method of heat removal there is an intensive cooling of the body "shell," optimal thermal state of the organism is ensured with a higher temperature of the "nucleus" (Table 2). Low temperature of the surface of the body provokes a decrease in the losses of moisture. In case of the performance of work limited in duration or episodic operations it is permissible to aim not only at an optimal microclimate of the space under the suit, but also at microclimatic conditions with which not all of the heat produced by the body is eliminated. In this case as well, however, it is necessary to ensure a thermally stable state of the of the organism even with its higher thermal content.

Table 2

(1) Parameters	(2) Heavy work	(3) Light work	(4) Rest	(5) Sleep
(6) Power heat consumption in Ergals	M-0-24.2	37.2-31.9	37.2-31.6	37.0-31.4
(7) Coefficient of heat transfer, α	27.0-24.0	24.0-20.0	20.0-16.0	16.0-12.0
(8) Temperature of the heat carrier, $t_{\text{с}}$	17-20	17-20	17-20	17-20
(9) Heat loss in Ergals	100-110	100-110	100-110	100-110
(10) Heat loss in Ergals	100-110	100-110	100-110	100-110
(11) Heat loss in Ergals	100-110	100-110	100-110	100-110
(12) Heat loss in Ergals	100-110	100-110	100-110	100-110
(13) Heat loss in Ergals	100-110	100-110	100-110	100-110
(14) Heat loss in Ergals	100-110	100-110	100-110	100-110
(15) Heat loss in Ergals	100-110	100-110	100-110	100-110
(16) Heat loss in Ergals	100-110	100-110	100-110	100-110
(17) Heat loss in Ergals	100-110	100-110	100-110	100-110
(18) Heat loss in Ergals	100-110	100-110	100-110	100-110
(19) Heat loss in Ergals	100-110	100-110	100-110	100-110
(20) Heat loss in Ergals	100-110	100-110	100-110	100-110
(21) Heat loss in Ergals	100-110	100-110	100-110	100-110
(22) Heat loss in Ergals	100-110	100-110	100-110	100-110
(23) Heat loss in Ergals	100-110	100-110	100-110	100-110
(24) Heat loss in Ergals	100-110	100-110	100-110	100-110
(25) Heat loss in Ergals	100-110	100-110	100-110	100-110
(26) Heat loss in Ergals	100-110	100-110	100-110	100-110
(27) Heat loss in Ergals	100-110	100-110	100-110	100-110
(28) Heat loss in Ergals	100-110	100-110	100-110	100-110
(29) Heat loss in Ergals	100-110	100-110	100-110	100-110
(30) Heat loss in Ergals	100-110	100-110	100-110	100-110
(31) Heat loss in Ergals	100-110	100-110	100-110	100-110
(32) Heat loss in Ergals	100-110	100-110	100-110	100-110
(33) Heat loss in Ergals	100-110	100-110	100-110	100-110
(34) Heat loss in Ergals	100-110	100-110	100-110	100-110
(35) Heat loss in Ergals	100-110	100-110	100-110	100-110
(36) Heat loss in Ergals	100-110	100-110	100-110	100-110
(37) Heat loss in Ergals	100-110	100-110	100-110	100-110
(38) Heat loss in Ergals	100-110	100-110	100-110	100-110
(39) Heat loss in Ergals	100-110	100-110	100-110	100-110
(40) Heat loss in Ergals	100-110	100-110	100-110	100-110
(41) Heat loss in Ergals	100-110	100-110	100-110	100-110
(42) Heat loss in Ergals	100-110	100-110	100-110	100-110
(43) Heat loss in Ergals	100-110	100-110	100-110	100-110
(44) Heat loss in Ergals	100-110	100-110	100-110	100-110
(45) Heat loss in Ergals	100-110	100-110	100-110	100-110
(46) Heat loss in Ergals	100-110	100-110	100-110	100-110
(47) Heat loss in Ergals	100-110	100-110	100-110	100-110
(48) Heat loss in Ergals	100-110	100-110	100-110	100-110
(49) Heat loss in Ergals	100-110	100-110	100-110	100-110
(50) Heat loss in Ergals	100-110	100-110	100-110	100-110
(51) Heat loss in Ergals	100-110	100-110	100-110	100-110
(52) Heat loss in Ergals	100-110	100-110	100-110	100-110
(53) Heat loss in Ergals	100-110	100-110	100-110	100-110
(54) Heat loss in Ergals	100-110	100-110	100-110	100-110
(55) Heat loss in Ergals	100-110	100-110	100-110	100-110
(56) Heat loss in Ergals	100-110	100-110	100-110	100-110
(57) Heat loss in Ergals	100-110	100-110	100-110	100-110
(58) Heat loss in Ergals	100-110	100-110	100-110	100-110
(59) Heat loss in Ergals	100-110	100-110	100-110	100-110
(60) Heat loss in Ergals	100-110	100-110	100-110	100-110
(61) Heat loss in Ergals	100-110	100-110	100-110	100-110
(62) Heat loss in Ergals	100-110	100-110	100-110	100-110
(63) Heat loss in Ergals	100-110	100-110	100-110	100-110
(64) Heat loss in Ergals	100-110	100-110	100-110	100-110
(65) Heat loss in Ergals	100-110	100-110	100-110	100-110
(66) Heat loss in Ergals	100-110	100-110	100-110	100-110
(67) Heat loss in Ergals	100-110	100-110	100-110	100-110
(68) Heat loss in Ergals	100-110	100-110	100-110	100-110
(69) Heat loss in Ergals	100-110	100-110	100-110	100-110
(70) Heat loss in Ergals	100-110	100-110	100-110	100-110
(71) Heat loss in Ergals	100-110	100-110	100-110	100-110
(72) Heat loss in Ergals	100-110	100-110	100-110	100-110
(73) Heat loss in Ergals	100-110	100-110	100-110	100-110
(74) Heat loss in Ergals	100-110	100-110	100-110	100-110
(75) Heat loss in Ergals	100-110	100-110	100-110	100-110
(76) Heat loss in Ergals	100-110	100-110	100-110	100-110
(77) Heat loss in Ergals	100-110	100-110	100-110	100-110
(78) Heat loss in Ergals	100-110	100-110	100-110	100-110
(79) Heat loss in Ergals	100-110	100-110	100-110	100-110
(80) Heat loss in Ergals	100-110	100-110	100-110	100-110
(81) Heat loss in Ergals	100-110	100-110	100-110	100-110
(82) Heat loss in Ergals	100-110	100-110	100-110	100-110
(83) Heat loss in Ergals	100-110	100-110	100-110	100-110
(84) Heat loss in Ergals	100-110	100-110	100-110	100-110
(85) Heat loss in Ergals	100-110	100-110	100-110	100-110
(86) Heat loss in Ergals	100-110	100-110	100-110	100-110
(87) Heat loss in Ergals	100-110	100-110	100-110	100-110
(88) Heat loss in Ergals	100-110	100-110	100-110	100-110
(89) Heat loss in Ergals	100-110	100-110	100-110	100-110
(90) Heat loss in Ergals	100-110	100-110	100-110	100-110
(91) Heat loss in Ergals	100-110	100-110	100-110	100-110
(92) Heat loss in Ergals	100-110	100-110	100-110	100-110
(93) Heat loss in Ergals	100-110	100-110	100-110	100-110
(94) Heat loss in Ergals	100-110	100-110	100-110	100-110
(95) Heat loss in Ergals	100-110	100-110	100-110	100-110
(96) Heat loss in Ergals	100-110	100-110	100-110	100-110
(97) Heat loss in Ergals	100-110	100-110	100-110	100-110
(98) Heat loss in Ergals	100-110	100-110	100-110	100-110
(99) Heat loss in Ergals	100-110	100-110	100-110	100-110
(100) Heat loss in Ergals	100-110	100-110	100-110	100-110

- 1. Endothelium
- 2. Heavy work
- 3. Light work
- 4. Rest
- 5. Sleep
- 6. Heat content (in kcal/kg)
- 7. Average temperature of the skin (in degrees)
- 8. Heat content (in kcal/kg)
- 9. Generation of moisture (grams/hour)
- 10. Rate of heart contractions (beats per minute)
- 11. Temperature of coolant at the input of the liquid cooled suit (in degrees)
- 12. Expenditure around 100 liters/hour)

Microclimatic conditions ensuring a thermally stable state of the organism during the accumulation of heat not exceeding 1.5 kcal/kg are considered permissible by us (See Table 1). At the same time there is observed a

USSR

UDC 612.792-06:612.591

GORODINSKIY, S. M., BAVRO, G. V., and IVANOV, G. A., Institute of Biophysics,
Ministry of Health USSR

"Some Characteristics of Perspiration in Man Exposed to High Temperatures"

Moscow, Gigiyena i Sanitariya, No 10, 1971, pp 33-36

Abstract: The purpose of the experiments was to determine the parts of the human body that perspire most after exposure to high temperatures. Moisture absorbents were applied as sensors to the head, trunk, arms, and legs of 15 subjects at rest and while exercising on a bicycle ergometer at temperatures of 50 and 38°C, respectively. In the resting subjects, perspiration appeared first and then became more intense on the forehead, neck, above the sternum, along the spine (rhomboid field), lower third of the forearms, dorsal surface of the wrists, knee joints, anterior surface of the shins, and dorsal surface of the feet. The perspiration gradually spread to the entire chest, back, shoulders, and thighs, involving all the sweat glands. The zones of intensive perspiration in the subjects riding the bicycle ergometer were found to be the same as in those at rest. The reason is that the intensity of perspiration is determined not by the number of sweat glands in a particular portion of skin but by the level of their activity, which is largely a function of the

1/2

USSR

GORODINSKIY, S. M., et al., Gigiyena i Sanitariya, No 10, 1971, pp 33-36

blood supply. The latter is particularly rich over tendons (aponeuroses) and the less developed muscles. The skin over the well-developed muscles of the extremities perspires much less than on the forehead, small of the back, or chest.

2/2

USSR

UDC 617-001.16-092.9-085.832.9-032:611.2

BAVRO, G. V., and PLETENSKIY, YU. G. (Moscow)

"The Effect of Cold Air Inhalation on the Autonomic Function and State of the Central Nervous System of a Rabbit Under Hyperthermia"

Moscow, Byulleten' Eksperimental'noy Biologii i Meditsiny, Vol 72, No 9, Sep 71, pp 32-35

Abstract: Experiments performed on rabbits subjected to overheating demonstrated that marked hyperthermia produces a sharp acceleration of the respiration and heart rates, with decreased bioelectrical activity and stimulation and reactivity of the cerebral cortex. Inhalation of cold air during hyperthermia produced a rapid restoration of the respiration rate and cerebral cortex reaction to light stimulation, with a gradual return and the EEG amplitude to its initial value. Thus, inhalation of cold air simultaneously with the effect of high environmental temperature prevents the development of disturbances in the body caused by overheating. A change back to inhalation of warm air caused an immediate increase in the respiration rate, drop in blood pressure, and so forth, revealing the special role of afferent signalization from the heat receivers in the development of disturbances of the regular function of the central nervous system under hyperthermia. During inhalation of cold air, signals from the cold receivers of the respiratory tract promote the normalization of body function. 1/1

1/2 031

UNCLASSIFIED

PROCESSING DATE--30OCT70

TITLE--PROBLEM OF HUMAN TOLERANCE UNDER THERMAL STRESSES -U-

AUTHOR--(03)-GORODINSKIY, S.M., BAVRO, G.V., KUZNETS, YE.I.

COUNTRY OF INFO--USSR

SOURCE--KOSMICHESKAIA BIOLOGIIA I MEDITSINA, VOL. 4, JAN.-FEB. 1970, P. 30-34

DATE PUBLISHED-----70

SUBJECT AREAS--BIOLOGICAL AND MEDICAL SCIENCES

TOPIC TAGS--THERMAL STRESS, BODY TEMPERATURE, HUMAN PHYSIOLOGY

CONTROL MARKING--NO RESTRICTIONS

DOCUMENT CLASS--UNCLASSIFIED

PROXY REEL/FRAME--1998/0289

STEP NO--UR/0453/70/004/000/0030/0034

CIRC ACCESSION NO--AP0120978

UNCLASSIFIED

2/2 031

UNCLASSIFIED

PROCESSING DATE--30OCT70

CIRC ACCESSION NO--AP0120978

ABSTRACT/EXTRACT--(U) GP-0- ABSTRACT. DISCUSSION OF THE VALUE OF VARIOUS PHYSIOLOGICAL INDICES AS CRITERIA OF THE THERMAL STRESS TOLERANCE OF MAN. RECTAL TEMPERATURE IS FOUND TO BE AN INSUFFICIENTLY INFORMATIVE CRITERION OF THERMAL STRESS TOLERANCE. A CLOSER RELATION IS ESTABLISHED BETWEEN TOLERANCE AND THE THERMAL CONDITION OF THE BODY SURFACE. IT IS ALSO SHOWN THAT THE MEAN TEMPERATURE OF THE BODY IS A USEFUL CRITERION AND THAT THE TOLERANCE CAN BE VARIED SUBSTANTIALLY BY LOCALIZED COOLING OF PORTIONS OF THE BODY.

UNCLASSIFIED

USSR

UDC: 621.3.091.1

BAVYKIN, N. D., KHMEL'NITSKIY, YE. A.

"Angles of Departure and Arrival in Short Wave Communication Lines During the Transition Hours"

Moscow, Elektrosvyaz', No 2, 1971, pp 4-13

Abstract: Measurements of field intensity over a range of 2900 km to clarify short wave propagation conditions during the transition hours are described, the results of an analysis of the experimental data are given, and a simplified method for making engineering estimates of the median deviations in departure and arrival angles is described in this paper. An example to illustrate estimation of trajectory deviations from the symmetrical through predictable ionosphere parameters is also explained. The data obtained in these experiments indicated that the cause of the reduction in the received signal level is the variation in geometrical parameters of the ionospheric layer which lead to asymmetrical trajectory propagation. Field strength measurements were made with an RGD 62 1 transmitting antenna, a symmetrical dipole nondirectional

1/2

USSR

BAVYKIN, N. D., et al, Elektrosvyaz', No 2, 1971, pp 4-13

receiving antenna, and a second receiver antenna of the BS2 type. The authors find that ionosphere deviations have a strong effect on the signal trajectory during the transition hours.

2/2

- 31 -

1/2 025 UNCLASSIFIED PROCESSING DATE--30OCT70
TITLE--THE RESULTS OF THE SURGICAL TREATMENT OF CANCER OF UPPER REGIONS OF
THE STOMACH -U-
AUTHOR-(03)-KUZIN, M.I., RYABTSEV, V.G., BAYANDIN, L.P.
COUNTRY OF INFO--USSR
SOURCE--KHIRURGIYA, 1970, NR 5, PP 47-52
DATE PUBLISHED-----70
SUBJECT AREAS--BIOLOGICAL AND MEDICAL SCIENCES
TOPIC TAGS--SURGERY, STOMACH, CANCER, CARCINOMA, SUTURE, HEART, LUNG,
METASTASIS
CONTROL MARKING--NO RESTRICTIONS
DOCUMENT CLASS--UNCLASSIFIED
PROXY REEL/FRAME--3003/0137 STEP NO--UR/0531/70/000/005/0047/0052
CIRC ACCESSION NO--AP0129393
UNCLASSIFIED

2/2 025

UNCLASSIFIED

PROCESSING DATE--30OCT70

CIRC ACCESSION NO--AP0129393

ABSTRACT/EXTRACT--(U) GP-0- ABSTRACT. AT THE N. N. BURDENKO FACULTY SURGICAL CLINIC BETWEEN 1948-1967 3704 PATIENTS WERE TREATED FOR CANCER OF THE STOMACH. OF THIS NUMBER IN 1375 CASES (37.8PERCENT) THE TUMOR WAS LOCATED IN THE UPPER REGIONS OF THE STOMACH. DURING THIS PERIOD OF TIME 300 GASTRECTOMIES AND 134 PROXIMAL RESECTIONS OF THE STOMACH WERE PERFORMED. POSITIVE RESULTS OF OPERATIONS WERE RECORDED. DURING THE LAST YEARS THERE WAS A SIGNIFICANT INCREASE OF OPERABLE PATIENTS WITH GASTRIC CARCINOMA (FROM 63.4PERCENT TO 80.1PERCENT), AS WELL AS THE RESECTABILITY (FROM 40.9PERCENT TO 49PERCENT). AMONG RADICAL OPERATIONS FOR GASTRIC CANCER TOTAL GASTRECTOMY WAS MORE OFTEN PERFORMED (FROM 13PERCENT TO 20.2PERCENT). THERE WAS A PRONOUNCED DROP OF THE POSTOPERATIVE LETHALITY AFTER GASTRECTOMY (FROM 30PERCENT TO 11.4PERCENT) AND AFTER PROXIMAL RESECTIONS (FROM 29PERCENT TO 13.3PERCENT). REDUCTION OF THE POSTOPERATIVE LETHALITY DEPENDED UPON DECREASE OF THE NUMBER OF SUCH POSTOPERATIVE COMPLICATIONS AS FAILURE OF ANASTOMOTIC SUTURES AND CARDIOPULMONARY COMPLICATIONS. THE REMOTE RESULTS DEPEND ON THE STAGE OF THE DISEASE, METASTASIZATION AND FORM OF THE TUMOR. A FIVE YEAR PERIOD AFTER GASTRECTOMY SURVIVED 18.2 PER CENT, A TEN YEAR PERIOD, 15 PERCENT OF PATIENTS. AFTER PROXIMAL RESECTION OF THE STOMACH 24.3 PERCENT OF CASES SURVIVED A FIVE YEAR PERIOD. FACILITY: FAKUL'TETSKAYA KHIRURGICHESKAYA KLINIKA I MMI IM. I. M. SECHENOVA.

UNCLASSIFIED

1/2 016

UNCLASSIFIED

PROCESSING DATE--04DEC70

TITLE--ACUTE RENAL INSUFFICIENCY DURING ACUTE GLOMERULONEPHRITIS IN
CHILDREN AND ITS TREATMENT WITH HEMODIALYSIS -U-
AUTHOR--(05)-SOROKINA, M.I., BAYANDINA, S.A., DANILINA, Z.A., LOKSHIN,
A.M., VERKHOVSKIY, B.D.
COUNTRY OF INFO--USSR

B

SOURCE--PEDIATRIYA 49(2): 26-30. 1970.

DATE PUBLISHED-----70

SUBJECT AREAS--BIOLOGICAL AND MEDICAL SCIENCES

TOPIC TAGS--KIDNEY FUNCTION, DIALYSIS, BLOOD, NEPHRITIS

CONTROL MARKING--NO RESTRICTIONS

DOCUMENT CLASS--UNCLASSIFIED

PROXY FICHE NO----FD70/605015/B10 STEP NO--UR/0546/70/049/002/0026/0030

CIRC ACCESSION NO--AP0140558

UNCLASSIFIED

2/2 016

UNCLASSIFIED

PROCESSING DATE--04DEC70

CIRC ACCESSION NO--AP0140558

ABSTRACT/EXTRACT--(U) GP-0- ABSTRACT. TO FIND OUT THE MAIN CRITERIA OF ACUTE RENAL INSUFFICIENCY IN ACUTE GLOMERULONEPHRITIS IN CHILDREN, AN ANALYSIS WAS MADE OF THE TREATMENT OF 10 PATIENTS, 7 OF WHOM WERE SUBJECTED TO 15 COURSES OF HEMODIALYSIS. SIX PATIENTS RECOVERED, IN 1 CASE THE DISEASE BECAME CHRONIC, 3 PATIENTS DIED. ACUTE RENAL INSUFFICIENCY IN ACUTE GLOMERULONEPHRITIS WAS CHARACTERIZED BY OLIGO-ANURIA WITH HYPOSISTENURIA, THREATENING HYPERPOTASSEMIA AND AZOTEMIA, DECOMPENSATED METABOLIC ACIDOSIS AND HYPERHYDRATION. WHEN DETECTING THE SYMPTOMATICS OF ACUTE RENAL INSUFFICIENCY, PATIENTS SHOULD BE TRANSFERRED TO SPECIALIZED NEPHROLOGICAL DEPARTMENTS WHERE HEMODIALYSIS CAN BE DONE IF REQUIRED. FACILITY: I. M. SECHENOV 1ST MOSCOW MED. INST., MOSCOW, USSR.

UNCLASSIFIED

USSR

UDC 547.241+547.27

KRASIL'NIKOVA, Ye. A., RAZUMOV, A. I., BAYANDINA, Ye. V., and ZARINOVA, V. G.

"The Reaction of the Ethyl Ester of Diphenylthiophosphinic Acid with α -Halide Substituted Simple Esters"

Leningrad, Zhurnal Obshchey Khimii, Vol 41, No 5, May 1971, pp 1173-1174

Abstract: The ethyl ester of diphenylthiophosphinic acid reacts with α -halide substituted simple esters. The following products were separated from the reaction mixture: diphenylalkoxyalkylphosphine sulfides, the ethyl ester of diphenyldithiophosphinic acid, and diphenyldi(alkoxyalkyl)-phosphonium chlorides.

1/1

1/2 020 UNCLASSIFIED PROCESSING DATE--09OCT70
TITLE--A WAY TO IMPROVE THE DIAGNOSIS OF HYMENOLEPIDOSIS -U-
AUTHOR--(02)-BAYANDIAN, D.G., MILENINA, YE.V. *B*
COUNTRY OF INFO--USSR
SOURCE--MEDITSINSKAYA PARAZITOLOGIYA I PARAZITARNYYE BOLEZNI, 1970, VOL
39, NR 2, PP 239-240
DATE PUBLISHED-----70
SUBJECT AREAS--BIOLOGICAL AND MEDICAL SCIENCES
TOPIC TAGS--DIAGNOSTIC METHODS, PEDIATRICS, PARASITIC DISEASE
CONTROL MARKING--NO RESTRICTIONS
DOCUMENT CLASS--UNCLASSIFIED
PROXY REEL/FRAE--1990/0953 STEP NO--UR/0358/70/039/002/0239/0240
CIRC ACCESSION NO--AP0109110
UNCLASSIFIED

2/2 020

UNCLASSIFIED

PROCESSING DATE--09OCT70

CIRC ACCESSION NO--AP0109110

ABSTRACT/EXTRACT--(U) GP-0- ABSTRACT. PHENASAL WAS USED FOR DIAGNOSTIC PURPOSE FOR DETECTION OF PATIENTS WITH HYMENOLEPIDOSIS IN CHILDREN'S COMMUNITIES IN THOSE INSTANCES WHEN EGGS OF H. NANA COULD NOT BE DETECTED IN SOME CHILDREN BY METHODS OF COPROLOGICAL DIAGNOSIS USING THREE REPEATED EXAMINATIONS. ON THE EVE OF THE FOURTH EXAMINATION, IN THE EVENING BEFORE SLEEP PHENASAL WAS GIVEN IN A DOSE OF 0.5-1.0 G TOGETHER WITH 0.1 G OF PURGEN; IN THE MORNING A FECAL SPECIMEN WAS COLLECTED FOR ANALYSIS. THE EFFECTIVENESS OF HYMENOLEPIDOSIS DIAGNOSIS AFTER USE OF PHENASAL INCREASED CONSIDERABLY. FACILITY: OTDEL MEDITSINSKOY GEL'MINTOLOGII INSTITUTA MEDITSINSKOY PARAZITOLOGII I TROPICHESKOY MEDITSINY IM. YE. I. MARTSINOVSKOGO MINISTERSTVA ZDRAVOOKHRANENIYA SSSR, MOSCOW.

UNCLASSIFIED

Acc. Nr:

AA0038333

Abstracting Service:
CHEMICAL ABST.

3/70

Ref. Code:

UR 0482

B

59091v Standardization of parathyroidin. Briskin, A. I.;
Mordovskii, K. P.; ~~Bayandurova, M. N.~~ (All-Union Scientific
Research Institute of Antibiotics) U.S.S.R. 254,021 (Cl. A
61k), 07 Oct 1969, Appl. 26 Apr 1968; From *Otkrytiya, Izobret.,
Prom. Obratzy, Tovarnye Znaki* 1969, 46(31), 75. Parathyroi-
din is standardized by administering the prepn. to exptl. animals
deprived of food and then detg. the Ca level in their blood. The
parathyroid gland is preliminarily removed from male rats.

MSCL

ms

/

REEL/F
19731442

02

USSR

UDC 546.3-19'791'65/66-154:536.7

BAYANOV, A. P.

"Thermodynamic Properties of Liquid Uranium Alloys With Some Rare Earth Elements"

Leningrad, Radiokhimiya, Vol 12, No 5, 1970, pp 768-771

Abstract: From data of the respective solubilities of uranium and La, Ce, Pr, Nd, Sm, and Yb in the liquid state, constants were determined on the basis of the theory of subregular solutions for the determination of the energy of component interaction on the interatomic level. The constants were used in turn to calculate partial molar thermodynamic characteristics of cerium in uranium and of uranium in cerium for the temperature range 1423-1523°K. It is claimed that on the basis of these constants properties of multicomponent uranium systems may be calculated.

1/1

Acc. Nr.

AP0034225

Abstracting Service:
CHEMICAL ABST. 4-70

B

Ref. Code
UR 0028

74189b Complex hexachloride of cerium(IV) with cesium.
Bayanov, A. P.; Slavkina, R. I. (Kafedra Obshch. Anal. Khim.,
Sib. Met. Inst., Novokuznetsk, USSR). *Zh. Neorg. Khim.*
1970, 15(1), 275-6 (Russ). Ce_2CeCl_6 formed as a yellow cryst.
ppt. when Ce(IV) and CsCl solns. were mixed together. Soly.
of Ce_2CeCl_6 increased in the order $CCl_4 < 96\% EtOH < 12$
 $N HCl < 8N HCl$. Ce_2CeCl_6 is stable in Et_2O and the above-
mentioned solvents but decomp. in water with evolution of Cl
and decoloration of the soln.

HMJR

7

1

REEL/FRAME

19710878

di

1/2 035 UNCLASSIFIED PROCESSING DATE--30OCT70
TITLE--THERMODYNAMICS OF DILUTE SOLUTIONS OF CERIUM IN MOLTEN MAGNESIUM
-U-
AUTHOR--BAYANOV, A.P. *B*
COUNTRY OF INFO--USSR
SOURCE--IZVEST. V.U.Z., TSVETNAYA MET., 1970, (1), 91-93
DATE PUBLISHED-----70

SUBJECT AREAS--MATERIALS, CHEMISTRY, PHYSICS
TOPIC TAGS--NONFERROUS LIQUID METAL, MAGNESIUM ALLOY, CERIUM ALLOY,
THERMODYNAMIC PROPERTY, ZINC ALLOY, ENTHALPY, ENTROPY, BIBLIOGRAPHY,
DISTRIBUTION COEFFICIENT

CENTREL MARKING--NO RESTRICTIONS
DOCUMENT CLASS--UNCLASSIFIED
PROXY REEL/FRAE--2000/1553 STEP NO--UR/0149/70/000/001/0091/0093
CIRC ACCESSION NO--AP0125179
UNCLASSIFIED

2/2 035

UNCLASSIFIED

PROCESSING DATE--30OCT70

CIRC ACCESSION NO--AP0125179

ABSTRACT/EXTRACT--(U) GP-0- ABSTRACT. THE THERMODYNAMIC PROPERTIES OF DILUTE SOLUTIONS OF CE IN MOLTEN MG WERE CALCULATED BY ANALYSING THE DISTRIBUTION COEFF. OF CE BETWEEN A MOLTEN CHLORIDE MIXTURE (NACL-KCL-MGCL SUB2) AND A MG-ZN ALLOY WITH VARIOUS MG CONTENTS. PROPERTIES THUS DETERMINED WERE THE ACTIVITY COEFF. AND THE EXCESS PARTIAL MOLAR FREE ENERGY, ENTROPY, AND ENTHALPY OF CE IN MG AT 970-1070DEGREESK. THE DISSOLUTION OF CE IN MG WAS CHARACTERIZED BY A CONSIDERABLE NEGATIVE DEVIATION FROM RAOULT'S RULE: I.E., THE CORRESPONDING SOLUTIONS WERE BY NO MEANS REGULAR.

UNCLASSIFIED

B

USSR

UDC 621.319.53:621.382.2.072.1:546.28:621.384.6

BAYANOV, B. F., IL'IN, A. V., PAKIN, V. N., PANOV, A. P., SUL'VESTROV, G. I.

"Generator of Current Pulses with an Amplitude of 10^6 and a Stability of $\pm 10^{-3}$ with a Repetition Frequency of 2 Hz"

Tr. Vses. soveshchaniya po uskoritelyam zaryazhen. chastits, 1968. T.1 (Works of an All-Union Conference on Charged Particle Accelerators, 1968. Vol 1), Moscow, 1970, pp 283-286 (from RZh--Elektronika i yeye primeneniye, No 8, August 1970, Abstract No 8A285)

Translation: This paper considers a generator created at the Institute of Nuclear Physics of the Siberian Branch of the Academy of Sciences, USSR, which at an inductive load of 0.1 microhenry guarantees a unipolar current pulse of sinusoidal form with a duration with respect to the starting point of 1.2 microsecond, the amplitude of which is equal to 10^6 a and the stability to plus or minus 0.1 per cent. The generator involves stored capacitance which is charged via a controlled rectifier into the primary winding of a transformer. For regeneration of energy, a recharge of the capacitance is performed via a special recharge choke coil and recharge diodes. As a second variation of the commutator, a gas-discharge rectifier was developed, which is controlled with the help of a pulse of the magnetic field. There are two references. V. I.

1/1

USSR

SHCHEVELEV, YU. S., PALILOV, V. N., and BAYANOV, M. A., Sverdlovsk Scientific Research Institute of the Timber Institute

"Suspension for Track Rollers of a Tracked Vehicle"

USSR Authors' Certificate No 356190, Cl. B 62d 55/16, filed 9 Mar 70, published 23 Oct 72 (from Otkrytiya, Izobreteniya, Promyshlennyye Obratzsy, Tovarnyye Znaki, No 32, 1972, p 57)

Abstract: 1. The suspension contains longitudinal levers, each of which is securely mounted on a horizontally arranged axis hinged to a side member of the tracked vehicle, and elastic elements which interact with stops which are motionless with respect to the axes. To improve the roadability of the tracked vehicle, the stops are made separate from the suspension levers, are positioned between the side members and arranged on the axis of each lever with angular displacement of one from the other.

2. Suspension as above, whose distinguishing feature is that the levers are made of two parts which are female to the track rollers, while the lever axes are hinged to the side flanges of the side members, which are female to the suspension levers.

1/1

BAYBAKOV

Baybakov, B. L., Zabita, G. A.	Reception of Optical Radiation Phase Modulated by a Superhigh-Frequency Signal	304
Popov, L. N.	Paraxial Optical Signal Limiter	309
Gusev, V. G.	Study of the Effect of Multimode Laser Emission on the Reception of Phase Modulated Signals	311
Korshunov, I. P.	Study of the Basic Parameters of Light-Guide Communications Lines	315
Gartenshteyn, F. E.	Gas Lenses for Optical Beam Wave Guides	323
Haykapart, O. I.	Structural Characteristics of Antennas for Photon Information Transmission Systems	331
Khromov, A. R., Rab- tikov, V. A., Kiyukhin, L. M.	Temperature Conditions of Thin Ferromagnetic Film when Recording Images by Laser Emission	340
Kiyukhin, L. M., Rabnikov, V. A., Khromov, A. D.	Thin Magnetic Film in Laser Beam Information Transmission Systems	350
Men'shikh, O. F.	Method of Precession Diagnostics of Small Disturbances of the Optical Activity and Indexes of Refraction of Optically Transparent Media using Laser Radiation	364
Men'shikh, O. F.	Procedure for Optical Differentiation of Amplitude Modulated Coherent Radiation	371
Men'shikh, O. F.	Study of the Optical Properties of Substances Based on the Inverse Faraday Effect	375
Sikotin, V. V., Samoylov, V. D.	Study of Logical Elements Based on a Semiconductor Laser Photodiode	380
Uspenskiy, A. V.	Possibility of Realizing Three Stable States in a Semiconductor Laser with Hemispherical Excitation	385
DeByugina, I. A., Korov, V. V., Dhozhenko, Yu. L.	Two-dimensional Scanning of an Optical Beam by Light Refraction in an Ultrasonic Field ...	389
DeByugina, I. A., Korov, V. V., Dhozhenko, Yu. L.	Laser System Insuring that an Image of an Object Will be Obtained on a Display Screen ...	395

27

TECHNICAL TRANSLATION

AKA / PSTCJF23-2015-12
89 Nov 72

ENGLISH TITLE: PROBLEMS OF LASER BEAM DATA TRANSMISSION
PROCEEDINGS OF THE FIRST ALL-UNION CONFERENCE, KIEV,
SEPTEMBER 1968

FOREIGN TITLE: PROBLEMY PEREDACHI INFORMATSII LAZERNYM IZLUCHENIYEM

AUTHOR: I. A. DERJUGIN, ET AL.

SOURCE: KIEV ORDER OF LENIN STATE UNIVERSITY
IMENI T.G. SHEVCHENKO

Translated for PSTC by ACS1

NOTICE

The contents of this publication have been translated as presented in the original text. No attempt has been made to verify the accuracy of any statement contained herein. This translation is published with a minimum of copy editing and graphics preparation in order to expedite the dissemination of information.

Approved for public release. Distribution unlimited.

USSR

UDC 621.315.592

BAYBAKOV, V.I.

"Generation Of Electromagnetic Wave In The Korbino Disk Made Of n-InSb"

Fizika i tekhnika poluprovodnikov, Vol 6, No 4, Apr 1972, pp 735-737

Abstract: The results are discussed of an experiment in which high-frequency generation was observed in specimens of n-InSb which had the form of a Korbina disk and were located in a magnetic field at 78° K. The concentration of electrons in the specimens amounted to $2 \cdot 10^{14} \text{ cm}^{-3}$, and the mobility to $5.5 \cdot 10^5 \text{ cm}^2/\text{v} \cdot \text{sec}$. The constant magnetic field with a magnitude up to 2 kilooersted was oriented with respect to the axis of the specimens, and the duration of the voltage pulse amounted to 10-200 microsecond with an amplitude up to 70 v. The form of the pulse current is shown for a signal in a regime of monochromatic generation and a signal in a regime of noise generation. The dependence is found of the intensity of the high-frequency signal on the radial drift stress. 2 fig. 6 ref. Received by editors, 19 July 1971.

1/1

1/2 037 UNCLASSIFIED PROCESSING DATE--30OCT70
TITLE--AMPLIFICATION OF HELICONS IN INDIUM ANTIMONIDE BY AN ELECTRON BEAM
-U-
AUTHOR--(02)-ABILOV, G.S., BAYBAKOV, V.I. *B*
CCOUNTRY OF INFO--USSR
SOURCE--PIS'MA ZH. EKSP. TEOR. FIZ. 1970, 11(3), 192-5
DATE PUBLISHED-----70
SUBJECT AREAS--PHYSICS
TOPIC TAGS--ELECTRON BEAM, INDIUM ANTIMONIDE SEMICONDUCTOR,
ELECTROMAGNETIC INTERACTION, PHASE VELOCITY, SINGLE CRYSTAL PROPERTY,
TEMPERATURE DEPENDENCE
CONTROL MARKING--NO RESTRICTIONS
DOCUMENT CLASS--UNCLASSIFIED
PROXY REEL/FRA--1987/0149 STEP NO--UR/0386/70/011/003/0192/0195
CIRC ACCESSION NO--AP0103828
UNCLASSIFIED

2/2 037

UNCLASSIFIED

PROCESSING DATE—30OCT76

CIRC ACCESSION NO—AP0103828

ABSTRACT/EXTRACT—(U) GP-0- ABSTRACT. A HOLE, DIAM. 3.2 MM., WAS DRILLED ALONG THE AXIS OF AN N-INSB SINGLE CRYSTAL, DIAM. 10 AND LENGTH 15 MM. AN ELECTRON BEAM PASSING THROUGH THE HOLE WAS FOCUSED BY AN AXIAL MAGNETIC FIELD. THE BEAM INTERACTED WITH HELICONS AT 90-130DEGREE SK AT MAGNETIC FIELDS OF 2-12 KOE. INTERACTION WAS ABSENT AT ROOM TEMP. THE PLOT ULTRA HIGH FREQUENCY POWER VS. THE ACCELERATING VOLTAGE OF THE BEAM EXHIBITED SEVERAL MAX. THE VELOCITY OF THE BEAM CORRESPONDED TO THE PHASE VELOCITY OF HELICONS, SO THAT FOR HELICONS AND A SLOW WAVE OF SPACE DISCHARGE, SYNCHRONISM WAS PRESENT IN THE BEAM.

UNCLASSIFIED

BAYBAKOV, Yu. I.

SO: JPRS 54019
9 SEP 71

UDC: 362.11(47-21)

LEVEL, STRUCTURE, AND DISTINCTIVE FEATURES OF EMERGENCY HOSPITAL CARE IN DIFFERENT TYPES OF CITIES

All-Union Health

(Article by Ye. A. Lesinova, V. V. Zhirareva, T. S. Belyakova, N. T. Trubilin, I. K. Smolovik, L. F. Sushchik, A. K. Plyusunov, Z. P. Ivanenker, A. P. Sarayev, Yu. I. Baybakov, All-Union Scientific Research Institute of Social Hygiene and Public Health Organization head N. A. Semashko, Kostovskaya, Ulyanovskaya and Kurskaya Oblast Health Departments; Moscow, Sovetskoye Zdravoohraneniye, Russian, No 7, 1971, submitted 16 February 1971, pp 18-25)

In spite of the know-how accumulated by Soviet public health in the area of planning and developing norms for medical care in hospitals, still unstudied is the matter of bed requirements referable to emergency hospitalization of patients and the structure of such requirements. Of special interest is the development and improvement of the network and structure of emergency hospitals founded on the basis of hospitalization in view of the specialized measures for further improvement of the CPSU and USSR Council of Ministers, "On Measures for Further Improvement of Public Health and Development of Medical Science in the Nation," as well as integration of emergency stations and hospitals, as reflected in order No 608, dated 6 August 1968, issued by the USSR Minister of Health.

In resolving planning and organizational problems pertaining to emergency hospital care it is not deemed possible to be governed by official reports, since the statistics on hospitalized patients include data on emergency hospitalization only referable to surgical emergencies whereas a considerable place is occupied by emergency hospitalization of therapeutic, obstetric-gynecological, infectious, and other patients.

For the purpose of substantiating the structure of the beds allocated for emergency hospitalization, the All-Union Scientific Research Institute of Social Hygiene and Public Health Organization, head N. A. Semashko, jointly with the oblast health departments of Rostovskaya, Ulyanovskaya, Kurakaya, Kalinigradskaya, and Vologodskaya oblasts and the Ministry of Health of Bashkir ASSR, conducted a complex study to determine the level, scope, and nature of emergency hospital care in different types of cities.

BAYBAKOV, Yu. I.

SO: JPRS 55015
25 JAN 72

111

UDC: 362.11(47-21:67-22)

DISTINCTIONS IN LEVEL AND STRUCTURE OF HOSPITAL CARE FOR RURAL PATIENTS IN DIFFERENT TYPES OF CITIES

(Article by Ye. A. Lofinova, M. V. Perekhina, V. M. Shipova, N. I. Trubilin, I. K. Smolovik, L. M. Shugun, A. K. Pivunov, Z. P. Zharanenko, Ye. F. Kolesnikov, A. F. Zhurav, Yu. I. Baybakov, All-Union Scientific Research Institute of Social Hygiene and Public Health, Organization imeni N. A. Semashko, Rostovskaya, Ul'yanovskaya, and Kurskaya oblast health departments; Moscow, Sovetskoye Zdravookhraneniye, Russian, No 12, 1971, submitted 24 March 1971, pp 16-21)

Urban therapeutic institutions play an important role in rendering qualified and particularly specialized care for the rural population.

It is a known fact that the volume of medical care rendered to the rural population by urban institutions is increasing annually, however, to date this is not taken into consideration in planning urban public health care. In addition, there are still insufficient special investigations to substantiate the rural residents demand for specialized hospital and extramural care at different stages of organization of rural public health.

The absence of differentiated standards of the demands of the rural population with regard to special forms of medical care makes it imperative to pursue in-depth investigations of the level and distinctions of the demand for different forms of therapeutic and prophylactic care in concrete institutions of different types of cities.

For this purpose, the ~~All-Union Scientific Research Institute of Social Hygiene and Public Health, Rostovskaya, Ul'yanovskaya, and Kurskaya oblast health departments, jointly with the~~ ~~oblast~~ ~~public health departments of Rostovskaya, Ul'yanovskaya, Kurskaya, Volgogradskaya oblasts and the Bashkir Ministry of Health conducted a complex study of the level and structure of hospital, polyclinic, and visiting consultation services offered to rural residents in the different cities.~~

In this article we submit the results of a study of the level and structure of hospital care rendered to the rural population in different types of cities in Rostovskaya, Ul'yanovskaya, and Kurskaya oblasts; data pertaining to other bases are undergoing statistical processing.

Acc. Nr: **AP0047246**

Ref. Code: **UR0504**

PRIMARY SOURCE: *Terapevticheskiy Arkhiv*, 1970, Vol 42, Nr 1, PP **92-94**

BIOCHEMICAL DIAGNOSIS OF THE ACTIVITY OF THE INFLAMMATORY PROCESS IN CHRONIC NONSPECIFIC PNEUMONIA

Yu. I. Baybakov, . A. M. Pleshkov

Summary

The article is devoted to biochemical diagnosis of the activity of the inflammatory process in chronic pneumonia. The authors studied the dynamics of the level of proteins, protein fractions, sialic acid in the blood of patients with chronic nonspecific pneumonia. The results obtained make it possible to draw a conclusion that diagnosis of exacerbation of chronic nonspecific pneumonia should be based on the complex methods of investigation including investigations of the total protein content, its fractions and glycoproteids.

-1/1

REEL/FRAME
19790753

Feb 2