

Begin reel

692

MIKHNEZEV, Anatoliy L'vovich, zasl. deyatel' nauki prof.;
SLEDZEVSKAYA, Irina Kazimirovna, kand. med. nauk;
YANOVSKIY, Georgiy Viktorovich, kand. med. nauk;
ZANAZDRA, N.S., red.; BOYKO, V.P., tekhn. red.

[Clinical phonocardiography] Klinicheskaiia fonokardiogra-
fiia. Kiev, Gosmedizdat USSR, 1963. 134 p. (MIRA 17:3)

ZANBERG, J.

"Assuring housing for brigades in collective farms." p.10 (MECHANIZATOR ROLNICTWA,
Vol.2, no.3, March 1953 Warszawa, Poland)

SO: MONTHLY LIST OF EAST EUROPEAN ACCESSIONS, VOL. ", #1, LIBRARY OF CONGRESS
August 1953, Uncl.

ZANCHENKO, A.

Filter for the purification of air. Voen. znan. 38 no.6:31-32
Je '62. (MIRA 15:6)

1. Inspektor Tsentral'nogo komiteta Dobrovol'nogo obshchestva
sodeyatviya armii, aviatsii i fletu.
(Air filters)

KAMINSKIY, V.; ZAMCHENKO, A.

Real people. Voen. znani. 41 no.3:41-42 № 165.

(MIRA 18:5)

ZANCHENKO, A.

Work of the OKN and OKN-1M filters with new components. Voen.
zhurn. 39 no.10:35 0 '63. (MIRA 16:11)

1. Starshiy inspektor spasatel'noy sluzhby Tsentral'nogo komiteta
Dobrovol'nogo obshchestva sodeystviya armii, aviatsii i flotu.

ZANCHENKO, V.

Portable gas analyzer for determination of gasoline vapors in air. V. Zanchenko and S. Vol'ga. *Recent Neft. Tekh., Neftepromstroi* B-4, No. 6, 20-7. *Referat. Zhur. Khim.* 1956, Abstr. No. 1211. A portable elec. gas analyzer, developed by All-Union Sci. Research Inst. for Ind. Safety, detcs. 1.1-3.0 mg/l. gasoline vapor content in the air. The resistance of a 5-ohm Pt wire is measured with a bridge. The resistance changes because of the increase of temp. caused by the reaction in the wire surface. Accuracy is within 10%.
N. Vasilen

ME3d
111
FB

ZANCHEV, V., inzh.

Studies on the prime cost of coal in Bulgaria. Min delo 18
no.7:8-15 J1 '63.

1. Direktor na DMP "Bolshevik".

ZANCHEVSKAYA, T.A.

Observations on the formation in mixed cultures of hemotoxins of
Clostridium perfringens and oedematiens. Zhur.mikrobiol, epid. i
immun. 41 no.5:105-109 My '64. (MIRA 18:2)

1. Odesskiy meditsinskiy institut imeni Pirogova.

L 10967-66 EWT(1)/EWA(J)/EWA(b)-2 JK

ACC NR: AP5028400

SOURCE CODE: UR/0016/65/000/009/0115/0120

AUTHOR: Zanchevskaya, T.A. ⁴⁴ ₆₅

ORG: Odessa Medical Institute Im. N.I. Pirogov (Odesskiy meditsinskiy institut) ⁴⁴ ₆₅

28
B

TITLE: Factors causing the restoration of toxic properties in centrifugates of Clostridium perfringens cultures which have lost their toxicity

SOURCE: Zhurnal mikrobiologii, epidemiologii i immunobiologii, no. 4, 1965, 115-120

TOPIC TAGS: microbiology, toxicology

ABSTRACT: The author performed a series of experiments to check the preservation period of protoxins (inactive toxins) in centrifugates of broth cultures of *Cl. perfringens*, using for this purpose strain No. 39 which does not have hemolytic properties. The minimal hemolytic dose of the centrifugate of a 20-hour culture of this strain varied within 0.5 - 0.4 ml. The centrifugates of 2-, 3-, 4-day and older cultures did not have hemolytic properties. To establish whether protoxins were in these centrifugates, the author mixed them in decreasing amounts with a dose (1/2 minimal hemolytic dose) of a centrifugate of a broth culture of *Cl. oedematiens* (strain No. 4) which had properties markedly potentiating the action of the toxin of *Cl. perfringens*. It was found that the

UDC: 576.851.655.097.21

Card 1/2

L 10967-66

ACC NR: AP5028400

hemolytic properties of old (2 to 11 days) broth cultures of *Cl. perfringens* are restored under the effect of nonhemolytic doses of the centrifugates of broth cultures of *Cl. oedematiens*. This indicated the presence of protoxins in old broth cultures of *Cl. perfringens* and their considerable stability. The activation of the hemolytic properties of the centrifugates of broth cultures of *Cl. perfringens* cultivated on media containing 0.27% M CaCl_2 was also apparently associated with activation of the protoxins formed in the broth cultures simultaneously with the toxins. Orig. art. has: 3 tables.

SUB CODE: 06 / SUBM DATE: 12Jun64 / ORIG REF: 013 / OTH REF: 003

Card 2/2

ZANCHEV, V., inzh.

Reserves for the increase of labor productivity at the State Mining
Enterprise "Bolshevik." (Min delo 17 no.4:3-6 Ap '62.

1. Direktor na Duzhavno to minno predpriatie "Bolshevik".

NETYKSA, V.M., prof. doktor tekhn. nauk; KHREN, I.S., kand. tekhn. nauk;
ZANCHEVA, M.I., kand. tekhn. nauk (Dnepropetrovsk)

Operational testing of brake shoes. Zhel. dor. transp. 41 no.10:
64-66 0 '59. (MIRA 13:2)

(Railroads--Brakes)

ACA

2000

Grain size of glass sand. STEPHAN Z. ZAND. *Schmelztechnik*, 2
[4] 52-56 (1951). A survey of technical literature on grain size
analysis of glass sand is presented. A 111

Grain size of glasscard. Stefan Z. Zari. Sklo i Ceram., 2 (3) 62-58 (1961).
A survey of technical literature on grain size analysis of glass card is
presented. A. D. I.

immediate source clipping

XII

ACS

Limestone and dolomite as basic raw materials in the glass

industry. Z.S.Zand. Sakko i Ceram., 2 (12) 267-71 (1951)—Z. gives the chemical analysis of limestones, dolomites, and magnesites, with particular considerations of native raw materials. Characteristics, extraction, identification, and serviceability of limestones, dolomites, and magnesites and their behavior during firing are discussed. A.B.I.

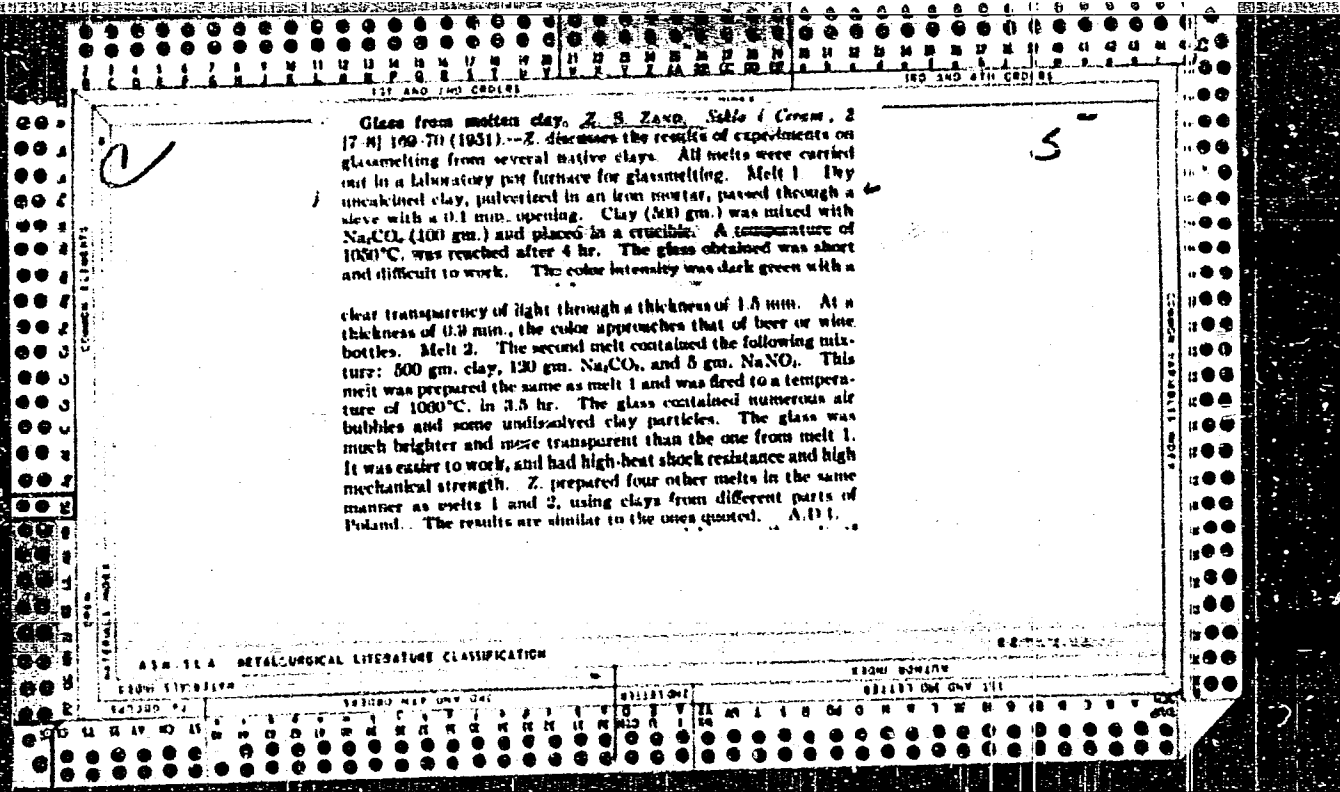

ZANDA, VACLAV FRANTISEK.

GEOGRAPHY & GEOLOGY

ZANDA, VACLAV FRANTISEK. Karlovy Vary; Stadtfuhrer. Praha, Sportovni
a turisticke nakl., 1958. 120 p.

Monthly List of East European Accessions (EEAI) LC, Vol. 8, No.5
May 1959, Unclass.

ZANDA, Vaclay Frantisek

Karlovarsko. Oblastni turisticky pruvodce cis. 2. (Karlovy Vary Area; Regional Tourist Guide, No. 2. 1st ed. illus., maps, bibl., indexes) Prague, Sportovni a turisticke nakl., 1957. 129 p.

Bibliograficky katalog, CSR, Ceske knihy, No. 32. 17 Sept 57. p. 677.

VEYSMAN, Yu.A.; ZANDANOV, A.B.

Differential diagnosis of a clavicle tumor and zones of its
functional reconstruction. Khirurgia 32 no.3:85 Mr '56. (MIRA 9:7)
(CLAVICLE--TUMORS)

VEYSMAN, Yu.A.; ZANDANOV, A.B.

Differential diagnosis of a clavicle tumor and zones of its
functional reconstruction. Khirurgiia 32 no.3:85 Mr '56. (MIRA 9:7)
(CLAVICLE--TUMORS)

ZANDANOV, I.M.

Changes in the number and composition of the population of the Bu-
ryat A.S.S.R.; based on population census materials. Trudy BKNII
no.5:188-196 '61. (MIRA 18:2)

RADNAYEV, Gombo Shirapovich; ZANDANOV, I.M., otv. red.;

[Ways of developing the light and food industries of the Buryat A.S.S.R.] Puti razvitiia legkoi i pishchevoi promyshlennosti Buriatskoi ASSR. Ulan-Ude, Buriatskoe knizhnoe izd-vo, 1965. 124 p. (MIRA 18:8)

ACCESSION NR: AT4042301

S/0000/63/003/000/0243/0253

AUTHOR: Grinberga, D.A., Zandart, Ya, Ya.; Zander, Yu. K., Laumanis, I. Ya

TITLE: Investigation of an experimental DC conduction pump

SOURCE: Soveshchaniye po teoreticheskoj i prikladnoj magnitnoj gidrodinamike. 3d, Riga, 1962. Voprosy* magnitnoj gidrodinamiki (Problems in magnetic hydrodynamics); doklady* soveshchaniya, v. 3. Riga, Izd-vo AN LatSSR, 1963, 243-253

TOPIC TAGS: conduction pump, direct current pump, pump testing

ABSTRACT: The authors have designed the experimental mercury system shown in Figure 1 of the Enclosure for the purpose of verifying the theory of DC compensation-type conduction pumps. The pump model to be tested 5 (Figure 1) is connected in series with pump 1 through valve 4, connecting tubes 2 and Venturi tube 7. The purpose of pump 1 is to compensate for the loss of pressure in the internal hydraulic circuit. The useful pressure, developed by the test pump 5 in the internal hydraulic circuit, is measured by means of mercury manometers 6, while the speed of the liquid metal is measured (in order to determine the productivity Q) by means of the Venturi tube. The authors note that the channel and the windings of the magnet of the pump to be tested

Card 1/3

ACCESSION NR: AT4042301

can be connected both in series and independently. Graphs are presented illustrating the P_Q and $\eta_a Q$ characteristics of a test model of a compensating pump with series and with independent excitation. Formulas are given for the maximum values of the pressure p_{im} and productivity Q . There is a discussion of the voltage U in the channel as a function of the productivity Q . A method is proposed for dividing the boundary current I into the so-called intrapolar current I and extrapolar current I . For the purpose of comparing the derived experimental data with the theory, the authors employed the calculation method proposed by Watt (Watt, D. A., O'Connor, R. J., and Holland E. Tests on an experimental d-c pump for liquid metals. Harwell, 1957; Watt, D.A. Analysis of experimental d-c pump performance and theory of design, Harwell, 1957). The results are analyzed from the point of view of agreement or lack of agreement between experimental and theoretical information. "The work was carried out under the supervision of Yu. A. Birzvalk (Cand. in the Tech. Sci.). Orig. art. has: 5 figures and 17 formulas.

ASSOCIATION: none

SUBMITTED: 04Dec63

ENCL: 01

SUB CODE: IE, EE

NO REF SOV: 002

OTHER: 002

Card 2/3

ACCESSION NR: AT4042301

ENCLOSURE: 01

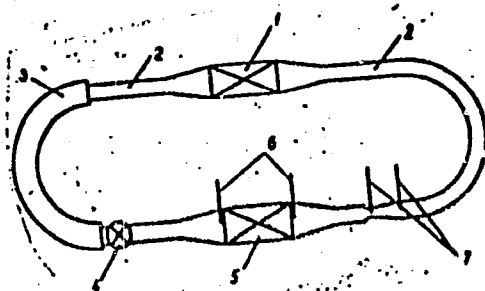

Fig. 1. Diagram of mercury system: 1 - auxiliary (or compensating) pump; 2 - connecting tubes; 3 - cooler, encompassing connecting tube 2; 4 - valve; 5 - pump to be tested; 6 - mercury manometers for the measurement of P_a ; 7 - Venturi tube manometers.

Card 3/3

ZANDBERG, A.I.

Hydraulic presses for rubber pressing. Kuz.-shtan.proizv. 1
no.6:26-28 Je '59. (MIRA 12:9)
(Hydraulic presses)

GOKHBERG, B. M., and ZANDBERG, E. Ya.

Mbr., Leningrad Physical Technical Institute, Acad. Sci, (-1946-)

"Ionization of Gases and Their Breakdown Strength," Dok. AN, 53, No. 6, 1946

Breakdown strength and ionization coefficients of gases.

K. Ya. Zandberg. *J. Tech. Phys.* (U.S.S.R.) 17, 299-308(1947)(in Russian). From measurements of the current intensities I (in amp.) in a strictly homogeneous elec. field under a variable voltage E (in v.) and a const. gas pressure p (in mm. Hg), curves of $\log(10^{11} \times I)$ were plotted against E/p for given electrode distances $x = 2, 3, 4,$ and 5 mm. From these graphs, the $\log(10^{11} \times I)$ plotted against x for given E/p , are straight lines diverging from a common origin at $x = 0$ where the ordinate corresponds to $I = I_0$; the linearity is in accord with the law of the impact-ionization current $I = I_0 e^{\alpha x}$ where α = first Townsend coeff., can thus be detd. for a given E/p from the slope of the corresponding $\log I = f(x)$ line. Measurements were made at 18° in: air, $p = 302$, E/p from 37 to 49; RfCl, $p = 300$, E/p 40 to 56; RfBr, $p = 180$, E/p 68 to 77; C₂H₆, $p = 200$, E/p 61 to 73; SF₆, $p = 122$, E/p 91 to 99; CHCl₃, $p = 38$, E/p 178 to 190; CCl₄,

$p = 31$, E/p 268 to 284. Results are represented in the form of plots of $\log(\alpha/p)$ against E/p ; with the values for Ne taken from I. I. Glotov (C.A. 32, 5997), the curves are nearly identical in shape, rising nearly linearly and vertically, and are shifted to increasing E/p in the order Ne, air, RfCl, RfBr, SF₆, CHCl₃, CCl₄. The point of intersection of each curve with the horizontal line drawn parallel to the E/p axis at $\alpha/p = 0.0215$, corresponding to the breakdown point in air (at $E/p = 41.5$ v./cm. mm. Hg), gives the value of E/p at which the given gas attains the same α/p as that corresponding to breakdown in air. This gives the relative elec. strengths of the gas in terms of E/E_{air} , with the values: Ne 0.17, RfCl 1.23, RfBr 1.44, C₂H₆ 1.83, SF₆ 2.22, CHCl₃ 2.45, CCl₄ 2.590. These figures agree closely with those derived from the slopes of the linear portions of the Paschen curves (cf. Hohlberg and Zandberg, C.A. 37, 1326). Consequently, breakdown in a gas occurs at an E at which α attains a definite value, so as to set up an internal field of space charge of sufficient intensity; the E necessary to fulfill that requirement varies from gas to gas. Elec. strength of a gas is detd. by the growth of α with E . This growth is the slower the greater the probability of inelastic losses of electron energy in the mol. prior to attainment of ionization. This applies particularly to heavy polyatomic highly polarizable mol.; higher elec. strength appears to parallel high heat capacity.

N. Thon

ASB-55A METALLURGICAL LITERATURE CLASSIFICATION

PA 36/49/15

ZANDBERG, E. YA

USSR/Chemistry - Ions, Electrolytic, Sep 48
Mass of
Chemistry - Alkali Metal Salts

"Negative Ions of Alkali Metals in Gas Discharges Occurring in Vapors of Alkali-Haloid Salts," V. M. Dukel'skiy, E. Ya. Zandberg, N. I. Ionov, Leningrad Physicotech Inst Imeni P. N. Lebedev, Acad Sci USSR, 2 pp

"Dok Ak Nauk SSSR" Vol LXII, No 3

Introduces results of preliminary experiments investigating composition of ions which form in a gaseous discharge in vapors of the alkali-haloid salts LiCl, NaI, and KI. Established the
36/49/15

USSR/Chemistry - Ions, Electrolytic, Sep 48
Mass of (Contd)

existence of negative ions of Li, Cl, and I and that their concentration in the discharge was large enough to enable easy discovery and measurement (mass). Submitted by Acad A. F. Ioffe, 14 Jul 48.

7/1/48

CA

Secondary electron emission under the action of negative ions. V. M. Dukel'nik and R. Yu. Zamilera. *Zhur. Ekspil. Teor. Fiz.* 19, 731-81 (1979). Current-voltage characteristics were detd. for the secondary electron emission of a Pt target under the action of pos. ions Na^+ and I^+ and of neg. ions Na^- and I^- , obtained by discharge in NaI vapor, and accelerated by potentials of 200-2200, 300-1040, 200-2150, and 300-1040 v., resp. Results are plotted in I_s/I_p = intensity ratio of the secondary electron and the primary ion current, against the potential difference, V , between the target and the collector. The coeff. of secondary emission γ , detd. from I_s/I_p , at $V = 12$ v., increases linearly with the energy of the ions, and is considerably higher, and increasing faster with the energy, for I^- than for I^+ , and for Na^- than for Na^+ . A deviation from linearity is found only with Na^+ ions, with γ increasing linearly up to about 1500 e.v. ($\gamma \sim 1$), then remaining very nearly const. For the mol. ions NaI^- and NaI^+ , of 740 e.v., $\gamma \sim 0.4$ and 0.07 , resp., i.e. again much higher for the neg. ion than for the corresponding pos. ion. Examples of data for the simple ions are: at 600 and 1000 e.v., I^+ , $\gamma = 0.8$ and 0.17 ; I^- , 0.32 and 0.65 ; Na^+ , 0.07 and 0.12 ; Na^- , 0.23 and 0.25 . The higher γ for neg. ions can be interpreted as an electron-liberating discharge of these ions at the surface of the target. The probability of that process is given by the difference of γ of the neg. and the pos. ions at equal energies. For I^- , it varies from 0.14 at 300 e.v. to 0.37 at 1000 e.v.; for Na^- , from 0.18 at 300 e.v. to 0.89 at 2200 e.v.

N. Thou

ZANDBERG, E. YA.

Leningrad Physico-Technical Inst., Dept. Physico-Math. Sci., Acad. Sci., (Mbr.,

Röntgenography Lab., -1940-; Mbr., -1942-c49-).

"Negative Alkaline Ions in Gas Discharge in Vapors of Alkali Halide Salts,"

ibid., 62, No. 3, 1948;

"Negative Ions of Rubidium and Cesium," ibid., 68, No. 1, 1949;

"The Problem of Secondary Electron Emission under the Action of Negative Ions,"

Zhur. Eksper. i Teoret. Fiz., 19, No. 3, 1949.

(1907515).

ZANDBERG,
ZANDBERG E. YA.

PA 169T93

Oct 50.

USSR/Physics - Gaseous Discharge Ions, Negative

"Negative Ions in a Gaseous Discharge in Vapors of Halide Salts of Alkali and Alkali-Earth Metals," V. M. Dukel'skiy, E. Ya. Zandberg, N. I. Ionov, Leningrad Physicotech Inst, Acad Sci USSR

"Zhur Eksper i Teoret Fiz" Vol XX, No 10, pp 877-885.

Mass-spectroscopic analysis of composition of negative ions occurring in gaseous discharges in vapors of subject salts: Establishes existence of Li-, Na-, K-, Rb-, Cs-. Ions Mg- and Ca- in discharges in vapors of MgCl₂ and CaCl₂ are not observed. Molecular negative ions of type MeX- and MeX₂- are observed in the case of alkali halide salts, and ions of type MeX-, and MeX₂-, and MeX₃- for CaCl₂ and MgCl₂ also are observed. Negative atomic ions of Ag are observed in discharges in vapors of AgI. Submitted 7 Mar 50.

PA 169T93.

Physics

NSA

DESTRUCTION OF NEGATIVE IONS BY COLLISIONS WITH ATOMS. V. M. Dubel'shii and E. Van-Humborg.

Dokl. Akad. Nauk SSSR, Ser. Phys. Chem. Math. Sci. (English transl.) 1970-83(1961) Nov. (in Russian)

During passage of Na⁻, K⁻, F⁻, Cl⁻, Br⁻, and I⁻ ions through He or A at ~10⁻³ mm Hg, the appearance of slow electrons was observed. The electrons were shown to arise from destruction of the negative ions by collision with atoms, and the cross sections for the process were determined. As an example, for Na⁻ and I⁻ ions of 100- to 1300-ev energy the cross section was found to be of the order of 10⁻¹⁸ to 10⁻¹⁶ cm² and to be directly proportional to the energy of the ion. A threshold energy of 250 ev was observed for I⁻ ions in He.

Leningrad Phys-Tech. Inst., A.S. USSR

Charge exchange between the negative ions Na^- , K^- , O_2^- , and O^- and O_2 molecules. (Unpublished Ph.D. thesis, University of Arizona, Tucson, 1962.)

The currents due to the electrons produced through decomposition of the primary neg. ions, and by the O_2^- ions to the through transfer of the neg. charge from the neg. ion to the O_2 mol., were successfully sept. by deflection in crossed elec. and magnetic fields. The effectiveness of this sept. was tested and confirmed by expts. with 720-e.v. Na^- and K^- ions in A in which only electrons but no A^- ions could be produced; no current due to ions of the primary beam scattered in the A^- gas was observed under these conditions. In contrast, with 720-e.v. K^- ions, and O_2 under 4.5×10^{-4} mm. pressure, there was a current that could be due only to O_2^- ions formed by charge exchange. Similar observations were made with Na^- ions and O_2 ; the current was proportional to the pressure of O_2 (between 1×10^{-7} and 8×10^{-6} mm. Hg.), which indicates that the charge exchange takes place in single collisions between the neg. ions and the O_2 mol. Charge transfers were also observed between primary O_2^- ions and O_2 mol. The values of the effective cross-sections q (in sq. cm.) for decomposition of the neg. ions and for charge exchange with O_2 mol. are: Na^- , 5×10^{-18} and 4×10^{-18} ; K^- , 6×10^{-18} and 4×10^{-18} ; O_2^- , 5×10^{-18} and 3×10^{-18} ; Cl^- , 3×10^{-18} and 2×10^{-18} ; OH^- , 6×10^{-18} and 3×10^{-18} ; O^- , 2×10^{-18} and 4×10^{-18} . Assuming, with Evans and Uri (C.A. 43, 5571), for the diffusion affinity of the O_2 mol., 0.7 e.v., one finds for the difference ΔW of the electron affinities of the neg. ion and of O_2 the values: Na^- , -0.5; K^- , -0.5; O_2^- , +1.5; Cl^- , +3.0; OH^- , +1.4; O^- , 0 e.v. It would seem, the smaller quantity, that q for the charge transfer is greater, the greater is ΔW . The fact, however, that q is greatest not for the resonance charge transfer from O_2^- to O_2 , but for Na^- and K^- , could be due to the large size of these ions. Evidently, the rule that q should be inversely proportional to the square of the ionization potential, which is valid for neg. ions, of the ionization potential, does not hold for neg. ions. In the latter instance, the transfer of the electron takes place in the elec. field of the neutral particle, which falls off rapidly with the distance; it therefore requires very close approach between the neg. ion and the neutral mol., and q cannot be much greater than the actual cross-section of the mol. To test this interpretation, the effective cross-section for the charge exchange between pos. ions O_2^+ and O^+ ions was detd. under the same conditions as the detn. for the neg. O_2^- ions. With 720-e.v. O_2^+ ions, q for the charge transfer $\approx 5 \times 10^{-18}$ cm.², i.e. greater than for O_2^- ions, although the ionization potential of O_2 (12.3 e.v.) is many times as great as its electron affinity.

235199

ZANDBERG, E. Ya.

USSR/Physics - Negative Arsenic Ions 11 Sep 52

"Negative Ions of Arsenic, Phosphorus, Sulfur, and
Thallium," V. M. Dukel'skiy, E. Ya. Zandberg

"Dok Ak Nauk SSSR" Vol 86, No 2, pp 263-265

Continuation of the study of the ability of atoms
and molecules to add an additional electron and to be converted
into free negative ions ("Zhur Eksper i Teoret Fiz"
20, 877 (1950); "Dok Ak Nauk SSSR" Vol 81, 767, 1951).
Here investigate the composition of ions that arise in a
gaseous discharge in nitrogen and ammonia, and also
in vapors of arsenic, phosphorus, sulfur, and halide
salts of thallium. Submitted by Acad A. F. Ioffe
5 Jul 52. 235199

Zandberg, E. Ya.

USSR/Physics - Nuclear physics

Card 1/ Pub. 22 - 17/63

Authors : Dukel'skiy, V.M., and Zandberg, E.Ya.

Title : Dissociation of molecular negative ions when colliding with atoms

Periodical : Dok. AN SSSR 99/6, 947-950, Dec 21, 1954

Abstract : Experiments, intended to reveal the processes which accompany collisions of negative ions with atoms of gases (He and Ar), are described. Ions of the following substances were used in the experiments: Te_2^- , Sb_2^- , Sb_3^- , Bi_2^- , NaJ^- , and NaJ_2^- . The formation of secondary ions and the dissociation of negative ions with electrons were only observed. Four references; 2-USSR (1915-1953). Graph; Diagram.

Institution: The Leningrad Physico-Technical Institute of the Acad. of Scs. of the USSR

Presented by: Academician A.N. Terenin, July 12, 1954

... ..

confirmed that for ions than for

target atoms and the
 taking place when surface atoms are ionized by fast uncharged
 atoms incident on them.—A. P. H.

Zandberg, E. Ya.

57-11-20/33

AUTHOR:

Zandberg, E. Ya.

TITLE:

The Surface Ionization of Potassium Atoms and KCl- and CsCl-Molecules in Electric Fields up to 2 MV/cm on Tungsten
(Poverkhnostnaya ionizatsiya atomov kaliya i melekul KCl i CsCl v elektricheskikh polyakh do 2 MV/cm na vol'frame)

PERIODICAL:

Zhurnal Tekhn. Fiz., 1957, Vol. 27, Nr 11, pp. 2583-2594 (USSR)

ABSTRACT:

The present work is the direct continuation of that of Ionov, N. I. (Zhurnal Tekhn. Fiz., 1956, Vol. 26, p. 2200). The displacement of the temperature threshold of the surface ionization of potassium atoms and of KCl- as well as of CsCl-molecules in dependence on the intensity of stress of the electric field in a cylindrical condenser with tungsten wire was investigated. In the case of the surface ionization of potassium atoms on tungsten in a field of ~ 2 MV/cm this displacement into the area of low temperatures amounted to $\sim 170^\circ$. To the same degree of ionization of K, KCl and CsCl within the temperature ranges in the various electric fields that were situated in the near of the threshold, temperatures corresponded, which, with the increase of the voltage of the field E on the thread, decrease proportional to \sqrt{E} . This coincides with the assumption that the evaporation operation of the adsorption atoms, which are mainly in ion-state, decreases in the presence of a strong electric field. In the case

Card 1/2

ZANDEBERG, E.Ya.

Surface ionization of NaCl and LiCl molecules on tungsten in electric fields up to 1.3×10^6 volts cm. Zhur. tekhn. fiz. 28 no. 11:2434-2443 (MIRA 12:1) N '58.

(Alkali halide crystals) (Ionization)

ZANBERG, E.Ya.; IONOV, N.I.

Surface ionization of lithium ions on the polycrystalline tungsten
in electric fields up to 1.3×10^6 volts/cm. Zhur. tekhn. fiz. 28
no.11:2444-2454 N '58. (MIRA 12:1)
(Lithium chloride) (Ionization)

ZANDBERG, E. Ya.

16

AUTHORS: Vasil'yev, G.F., Politova, M.M., Shabel'nikova, A.E.,
Pervova, L.Ya. and Yasnopol'skiye, A.A.

TITLE: Interdepartmental Seminar on Cathode Electronics (The 11th Meeting) (Mezhduvedomstvennyy seminar po katodnoy elektronike) (11-e zasedaniya)

PERIODICAL: Radiotekhnika i elektronika, 1959, Vol 4, Nr 4, PP 731 - 732 (USSR)

ABSTRACT: A meeting of the seminar took place on December 1, 1958 at the Institut radiotekhniki i elektroniki AN SSSR (Institute of Radio-engineering and Electronics of the Ac.Sc.USSR). During the meeting 8 papers were read. Yu.G. Ptushinskiy read a paper entitled: "Kinetics of the Adsorption of Oxygen on the Surface of Tungsten". The second paper, by I.M. Dykman and S.M. Pakar, dealt with "The Adsorption Photo-effect of Semiconductors in the Region of the Exciton Light Absorption". The paper by T.L. Matiskaychik was devoted to "The Problem of the Secondary Electron Emission of Fine Films of a Number of Organic Substances". The problem of "Surface Ionisation in a Strong Electric Field on a Surface with a Non-homogeneous Work Function" was considered by E.Ya. Zandberg and N.I. Ionov. I.N. Bakulina and V.V. Tonov read a paper entitled "Determination of the Electron Attachment Energy and of the Potentials of Atoms by the Method of Surface Ionisation". N.L. Yasnopol'skiy and A.P. Alekseyevskiy dealt with the problem of "Passage of Steady-state Currents Through One of the Contacts by Means of Electron Bombardment". The lecture by D.A. Ganchev and K.G. Ekin discussed the following - "The Possibility of the Analysis of the Total-energy Distribution of Electrons in a Quasi-spherical Condenser". The work by M.L. Kapitsa, S.A. Fridrikhov and A.R. Shul'man dealt with an investigation of the secondary electron emission and the characteristic energy losses of a number of dielectrics (glass, mica, fluorite and alkali-haloid monocrystal).

Card 2/2

USCIB-DC-44997

SOV/53-67-4-2/7

28(8)

AUTHORS: Zandberg, E. Ya., Ionov, N. I.

TITLE: Surface Ionization (Poverkhnostnaya ionizatsiya)

PERIODICAL: Uspekhi fizicheskikh nauk, 1959, Vol 67, Nr 4, pp 581-623 (USSR)

ABSTRACT: The authors give a survey of the phenomena of surface ionization taking special account of the theory. The following subjects are dealt with by the individual parts: I. Surface ionization with formation of positive ions in general representation; 1) emission formulas for a homogeneous surface without electric field, 2) emission formulas for a homogeneous surface with electric field, 3) surface ionization of atoms on semiconductors, 4) emission formulas for an inhomogeneous surface, 5) thresholds in the temperature-dependence of the surface ionization current. In part II the results obtained by a number of experimental works on positive surface ionization are compiled. Individual chapters deal with the following subjects: 6) The methods of investigating positive surface ionization. 7) The positive surface ionization of Cs-, Rb-, and K-atoms on tungsten in weak electric fields. 8) The positive surface ionization of Na- and Li-atoms on tungsten in weak fields. 9) The positive surface ionization of alkali-halide

Card 1/3

SCV/53-67-4-2/7

Surface Ionization

salts on tungsten weak fields. 10) The positive surface ionization of alkali metal atoms and molecules of alkali halide salts on platinum in weak fields. 11) The surface ionization of other elements and other compounds in weak fields (on tungsten). 12) The investigation of the energy distribution of positive ions (Fig 14). 13) The positive surface ionization in electric fields (10^4 v/cm). 14) The determination of the isothermal evaporation heats of ions and atoms on the surface. 15) Measurement of the ionization coefficient of K- and W-atoms. In part III of the paper the surface ionization with formation of negative ions is discussed in short. Individual chapters deal with the following: 16) The negative surface ionization on homogeneous surfaces. 17) Negative surface ionization on spotted surfaces. 18) Discussion of investigation methods. 19) Measurement of the temperature dependence of the negative ion current (Figs 21-23). 20) Determination of the energy of affinity to the electron by the method of negative surface ionization (Tables 1 and 2). - The paper gives a detailed description of the problems, methods, and results connected with the phenomena of surface ionization. The material was obtained solely from published works. The paper is of great value for scientists dealing with these problems on account of its clearness, its wealth of material, and its comprehensive

Card 2/3

Surface Ionization

SOV/53-67-4-2/7

account of publications. There are 23 figures, 2 tables, and 113 references, 66 of which are Soviet.

Card 3/3

ZANDBERG, E. Ya.

82156
S/048/60/024/05/01/017
B019/B067

9.3120

AUTHOR:

Zandberg, E. Ya.

TITLE:

Influence Exercised by an Electric Field on the
Temperature Threshold of the Occurrence of Positive Ions
in Surface Ionization of Atoms ²¹

PERIODICAL:

Izvestiya Akademii nauk SSSR. Seriya fizicheskaya,
1960, Vol. 24. No. 6, pp. 629-634

TEXT: This paper is the reproduction of a lecture delivered at the 9th All-Union Conference on Cathode Electronics from October 21 to 28, 1959 in Moscow. The ionization of a surface under the action of an electric field is investigated, which sucks off the produced ions at temperatures below the threshold temperature. Formula (1) is given, which describes the flux n of atoms toward the surface in the steady case. This formula contains corrections for the electric field which has the field strength E on the surface. If only a field with a few megavolts per cm is dealt with and if only such metal atom pairs are studied with which the threshold range of temperatures is distinctly marked, formula (1) can be

Card 1/3

*

Influence Exercised by an Electric Field on the Temperature Threshold of the Occurrence of Positive Ions in Surface Ionization of Atoms

82156
S/048/60/024/06/01/017
B019/B067

replaced by formula (3): $n_0 \approx NC \exp \left\{ -\left(1_+ - \psi\right)/kT \right\}$, where N is the atomic concentration on the surface and 1_+ the isothermal heat of evaporation of ions. ψ concerns the correction for the electric field. The author then derives the expression (7) for ψ , and thus obtains formula (8): $n_0 \approx NC \exp \left\{ -\left(1_+ - \epsilon \sqrt{E} + \epsilon Ex_{cr}\right)/kT \right\}$ for (3). In this formula, C is a coefficient depending weakly on T, x_{cr} is the critical distance of the charge exchange of the atoms adsorbed on the surface, ϵ is the charge of the ions. Some formulas for x_{cr} and ψ_{max} are derived, and the determination of x_{cr} is dealt with. Condition (13) is given from (8) for the constant flux which for a linear dependence of the form $T = f(\sqrt{E})$ assumes the shape (14) $const = \left(1_+ - \epsilon \sqrt{E}\right)/kT$. Therefrom a new possibility is obtained for determining the heat of evaporation of ions when ϵ is smaller than γ (γ is the ionization potential of atoms). Experiments were made on the temperature dependence of the surface ionization in

Card 2/3

Influence Exercised by an Electric Field on
the Temperature Threshold of the Occurrence of
Positive Ions in Surface Ionization of Atoms

82156
9/048/60/024/06/01/017
B019/B067

electric fields with field strengths of up to 7 Mv.cm^{-1} . The functions $T = f(\sqrt{E})$ shown in Figs. 4 and 5 were constructed on the basis of these results. From these diagrams, x_{cr} could be determined for K^+ ions according to formula (13). The author determined $x_{cr} \approx 4 \text{ \AA}$. With the less accurate formula (12) 7 \AA were obtained. The heat of evaporation calculated according to formula (15) on the basis of the results obtained for K^+ ions on tungsten is found to be 2.2 to 2.3 ev. The method described here allows an evaluation of the character of the dependence of heat of evaporation of ions on the degree of coating of the surface by ionizable atoms. The author thanks H. I. Ionov for interesting discussions. There are 6 figures and 9 references: 8 Soviet and 1 British.

ASSOCIATION: Leningradskiy fiziko-tekhnicheskii institut Akademii
nauk SSSR
Leningrad Physicotechnical Institute of the Academy of
Sciences, USSR

Card 3/3

24.2100,24.7400

77314
SOV/57-30-2-11/18

AUTHOR:

Zandberg, E. Ya

TITLE:

Influence of the Electric Field on the Temperature Threshold for the Positive Ion Appearance During Surface Ionization of Atoms

PERIODICAL:

Zhurnal tekhnicheskoy fiziki, 1960, Vol 30, Nr 2, pp 205-215 (USSR)

ABSTRACT:

The prime goal of the author was to obtain an estimate for the critical distance x_{kp} of the charge-exchange phenomenon. In absence of this critical distance, the ions during surface ionization would be formed on the surface of the metal with a definite heat of evaporation. If one would then add an outside applied field, the heat of evaporation of the ions would in this simplified case vary as $e \sqrt{eE}$, following the law of Schottky as in the case of thermoelectron emission. In case of significant values of x_{kp} one would expect a measurable deviation from Schottky law, and since the heat of evaporation is proportional to the temperature

Card 1/10

Influence of the Electric Field on the
Temperature Threshold for the Positive
Ion Appearance During Surface Ionization
of Atoms

77314
SOV/57-30-2-11/18

threshold for the positive ion emission, the author proceeded to measure these thresholds. The present paper is essentially a continuation of previous investigations by the author (ZhTF, XXVII, 2583, 1957), extended in the region of higher field intensities with the hope to obtain better estimates for the x_{kp} value.

The details of the experimental setup were described earlier (ZhTF, XXVIII, 2434, 1958). This diagram is on Fig. 2. The filament (1) was here thinner than in previous experiments in order to achieve surface fields up to 7 mv/cm. It is surrounded by a system of cylinder (2), (3), (4), and (5), of which (4) is an ion collector, (2) and (3)-transparent grid cylinders suppressing the secondary collector currents, (5)-a shield. Evaporator (6) and (7) is identical to those used previously. The filament continued through the eyelet (8), 0.5 mm in diameter and was stretched by means of the adjustable weight (9). The loop (11) prevented vibrations and guided the copper contact (10).

Card 2/10

Influence of the Electric Field on the Temperature Threshold for the Positive Ion Appearance During Surface Ionization of Atoms

Fig. 2. Diagram of the setup.

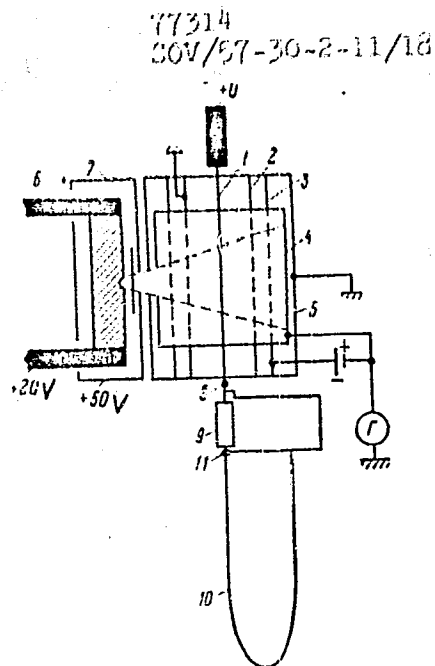

Card 3/10

Caption for Fig. 3 on Card 5/9

77314 SOV/57-30-2-11/18

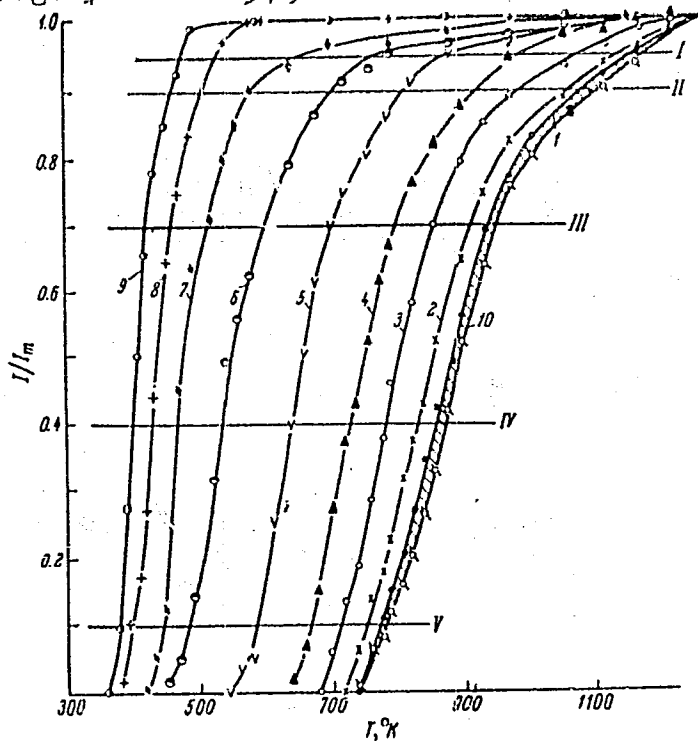

Card 4/10

Influence of the Electric Field on the
Temperature Threshold for the Positive
Ion Appearance During Surface Ionization
of Atoms

77314

SOV/57-50-2-11/13

FIG. 3. Ionization curves of CsCl for various E:
(1) E = 35.2 kv/cm; (2) E = 105.6 kv/cm; (3) E = 352 kv/cm;
(4) E = 704 kv/cm; (5) E = 1.76 mv/cm; (6) E = 2.81 mv/cm;
(7) E = 4.22 mv/cm; (8) E = 5.63 mv/cm; (9) E = 7.04 mv/cm;
(10) E = 35.2 kv/cm at end of measurements.

Filaments of 8μ in diameter could be heated up to
 $T = 1500^\circ \text{K}$. A TSVL-100 pump produced a 1 to $3 \cdot 10^{-7}$
tor vacuum. Temperatures were measured by means of a
microoptical pyrometer. The author investigated the
surface ionization of K atoms and CsCl molecules.
Typical results are on FIG. 3. Here I - ion current at
temperature T, I_m - saturation current on the plateau
of the curve. The author notes that at $E = 7 \text{ mv/cm}$
this saturation value is reached at approximately
 500°K , which indicates that the CsCl molecules are

Card 5/10

Influence of the Electric Field on the Temperature Threshold for the Positive Ion Appearance During Surface Ionization of Atoms

77314
SOV/57-30-2-11/18

practically dissociated on the tungsten surface at such a low temperature that the process is apparently of a catalytic nature. The experimental curves served to establish a second set of curves, shown on Fig. 5. Experimental points lie almost along straight lines. According to the theory, however, there should be a departure from a straight line behavior proportional to the size of x_{kp} since x_{kp} enters the formula for the correction in the heat of evaporation $\Delta \epsilon_+$

$$\Delta \epsilon_+ = e\sqrt{eE} - eEx_{kp}, \quad (5)$$

The theoretical curves for different values of x_{kp} are plotted on Fig. 7. Comparing Fig. 5 and 7 the author concluded that $x_{kp} \leq 4 \text{ \AA}$, contrary to the theoretical computations by Veksler (DAN Uzb. SSR. 5, 5, 1955). He also concludes that the Schottky expression for the interaction force between the charged particle and the conducting surface holds up to distances

Card 6/10

Influence of the Electric Field on the Temperature Threshold for the Positive Ion Appearance During Surface Ionization of Atoms

77314
SOV/57-30-2-11/18

Fig. 5. Temperature versus field intensity for various degrees of surface coating in case of CsCl I/I_m was: (I) 0.95; (II) 0.9; (III) 0.7; (IV) 0.4; (V) 0.1.

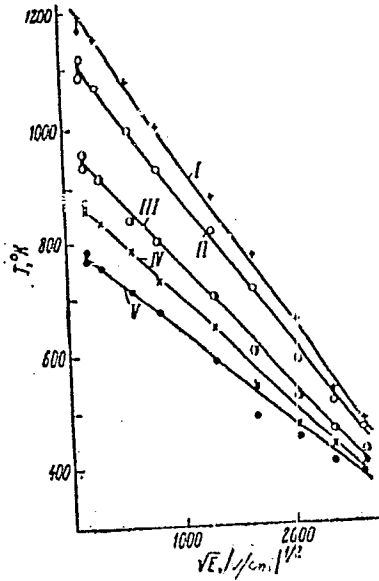

Card 7/10

Influence of the Electric Field on the Temperature Threshold for the Positive Ion Appearance During Surface Ionization of Atoms

77314
SOV/57-30-2-11/18

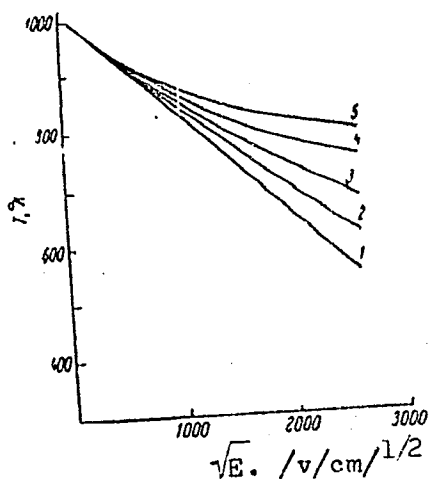

Fig. 7. Relationship $T = f(\sqrt{E})$ for $\Delta l_+ = e \sqrt{eE - eEX_{kp}}$. (1) $x_{kp} = 0$; (2) $x_{kp} = 2 \text{ A}$; (3) $x_{kp} = 4 \text{ A}$; (4) $x_{kp} = 6 \text{ A}$; (5) $x_{kp} = 8 \text{ A}$.

Card 8/10

Influence of the Electric Field on the
Temperature Threshold for the Positive
Ion Appearance During Surface Ionization
of Atoms

77314
SOV/57-30-2-11/18

of 7 A. This is significantly less than what can be obtained in tests with the thermoelectronic emission in strong electric fields. Since the threshold shift is related to the heat of evaporation of ions, the author was able to derive an equation for this heat l_+ using two points on the $T = f(\sqrt{E})$ curves:

$$l_+ = \varepsilon \sqrt{\varepsilon} \frac{T_2 \sqrt{E_1} - T_1 \sqrt{E_2}}{T_2 - T_1} \quad (11)$$

In the case of K, l_+ came out to be about 2.2 ev, and quite independent on the degree of surface covering. This is in fair agreement with results obtained by other researchers. This l_+ value can in turn be used for estimating the lower limit of x_{kp} , and the author obtained $x_{kp} \geq 1.8$ to 1.5 A. In

Card 9/10

Influence of the Electric Field on the
Temperature Threshold for the Positive
Ion Appearance During Surface Ionization
of Atoms

77314

804/57-30 2-11/15

an analogous manner l_+ for Cs^+ is between 1.6 and 1.8
ev which correspond to $x_{kp} \cong 2$ to 2.2 A. In this case
 l_+ depended on the degree of surface covering due
probably to a significant influence of the covering
on the adsorption of Cs atoms. Professor Ionov dis-
cussed many times the questions presented in this paper.
There are 7 figures; and 15 references, 13 Soviet, 2
U.K. The U.K. references are: P. B. Moon a. M. L.
Olliphant, Proc. Roy. Soc., A137, 463, 1932; R. C. Evans.
Proc. Roy. Soc., A139, 604, 1933.

ASSOCIATION:

Physico-Technical Institute AS USSR, Leningrad (Fiziko-
tekhnicheskiiy institut AN SSSR, Leningrad)

SUBMITTED:

June 15, 1959

Card 10/10

04/31

S/057/60/030/010/011/019
B013/B063

26.1420

AUTHOR: Zandberg, E. Ya.

TITLE: Surface Ionization of Indium and Thallium Atoms on Poly-crystalline Tungsten in Electric Fields up to 2 mv/cm

PERIODICAL: Zhurnal tekhnicheskoy fiziki, 1960, Vol. 30, No. 10, pp. 1215 - 1221

TEXT: Formulas for emission from inhomogeneous surfaces are given in Refs. 2 and 3 where three cases of ionization were treated. Now, the author studies the case $\varepsilon(V - \phi_k \max - \psi) \gg kT$ (1) with the help of the method described in Ref.1. ε - ion charge, V - ionization potential of the atom, ϕ_k - local value of the work function of the surface, ψ - correction to the work function for the presence of an electric field on the surface of an electric field by which the ions are sucked off; $\psi = \sqrt{\varepsilon E}$ for $E \sim 1$ mv/cm. The experimental device is schematically shown in Fig.1. The author describes the surface ionization of indium atoms on polycrystalline tungsten between 1900 and 2500°K and at a field

Cará 1/3

84731

Surface Ionization of Indium and Thallium Atoms on Polycrystalline Tungsten in Electric Fields up to 2 mv/cm

S/057/60/030/010/011/019
B013/B063

strength of 30 kv/cm to 2.1 mv/cm on the surface. Fig.3 indicates that the temperature dependence of the In^+ current on W follows an exponential law. The values for the actual work function ϕ^* determined from Fig.3 and formula (9) are collected in a Table together with values of ϕ^* for Na and Li. The author attempted to measure the temperature dependence of the surface ionization of thallium on tungsten (Fig. 4). It may be assumed that within the limits of error the values of ϕ^* obtained for In and Tl are in agreement. As has already been done in previous papers, the measured values of E are compared with the values determined by means of the Schottky effect. It was found that the dependence of surface ionization on the electric field strength for surfaces having different work functions but all satisfying condition (1) follows the simple Schottky rule at all values of E. This is also in agreement with the theoretical predictions. All conclusions drawn from the theory of surface ionization on inhomogeneous surfaces were confirmed for (1) by the experiments with indium. Finally, an estimate is given of the maximum local work function of polycrystalline tungsten, which

X

Card 2/3

Surface Ionization of Indium and Thallium
Atoms on Polycrystalline Tungsten in
Electric Fields up to 2 mv/cm

84731
S/057/60/030/010/011/019
B013/B063

approaches the results obtained by Smith (Ref.11) and Becker (Ref.9).
The author thanks Professor M. I. Ionov for discussions. There are
6 figures, 1 table, and 12 references: 8 Soviet.

ASSOCIATION: Fiziko-tehnicheskiy institut AN SSSR, Leningrad
(Institute of Physics and Technology AS USSR, Leningrad)

SUBMITTED: May 24, 1960

✓

Card 3/3

ZANDBERG, E.Ya.; IONOV, N.I.

Emission of positive molecular ions from heated surfaces in vacuum. Dokl. AN SSSR 141 no.1:139-142 N '61. (MIRA 14:11)

1. Fiziko-tekhnicheskiy institut im. A.F.Ioffe AN SSSR.
Predstavleno akademikom B.P. Konstantinovym.
(Ionization)

34211

S/057/62/032/002/012/022
B124/B102

26.2317
AUTHORS:

Zandberg, E. Ya., Paleyev, V. I., and Tontegode, A. Ya.

TITLE:

Dependence of the temperature threshold of surface ionization of cesium on tungsten on the cesium vapor tension

PERIODICAL:

Zhurnal tekhnicheskoy fiziki, v. 32, no. 2, 1962, 208 - 213

TEXT: A uniform electrode surface is considered which is only slightly covered by adsorbed atoms of the ionized element.

$$I^+ = \frac{\epsilon s A n}{\Lambda + \exp\left(\frac{\epsilon}{kT}(V - \psi - \gamma)\right)}$$
 holds for the temperature dependence of the

surface ionization current, where ϵ is the ion charge, s is the ionizing surface area, Λ is the ratio of the statistical sums of ionic and atomic states, n is the atomic flux per surface unit area per second, V is the ionization potential of the atom, ψ is the work function of the surface, and γ is the correction to ψ for the effect of an electric surface field. If $V - \phi - \psi < 0$, the surface ionization current reaches its maximum; with $T = 0$ and $\psi + \gamma - V \gg kT$ the current remains close to its maximum. The section

Card 1/2

X

34211
S/057/62/032/002/012/022
B124/B102

Dependence of the ...

bd (Fig. 1) is termed the threshold region of the surface ionization curve, and T_0 is the threshold temperature. In the steady state, the flux of atoms n incident on a homogeneous surface is

$$(4) \quad n = N \left[C \exp \frac{-(l_+ - \psi_1)}{kT} + D \exp \frac{-(l_0 + \psi_2)}{kT} \right] = N \left[C \exp \frac{-l'_+}{kT} + D \exp \frac{-l'_0}{kT} \right]^{(1)}$$

where N is the number of atoms per cm^2 , C and D are constants slightly dependent on T , l_+ and l_0 are the isothermal evaporation heats of ion and atom, respectively, in the absence of an electric field near the surface, and ψ_1 and ψ_2 are correction factors for such a field (E). The surface

ionization coefficient is $\beta = \frac{NC}{n} \exp \left(-\frac{l'_+}{kT} \right)$. If $\ln n = C' + \ln \frac{N}{N_1} +$

$\frac{l'_+}{k} \left(\frac{1}{T_{01}} - \frac{1}{T_0} \right)$ (6), where n_1 is a fixed flux of atoms, and T_{01} is the relevant threshold temperature, and N/N_1 is slightly temperature-dependent, the

Card 2/5/4

X

of us on W was studied a/scale X

34211

S/057/62/032/002/012/022
B124/B102

Dependence of the ...

temperature dependence $\ln n = f\left(\frac{1}{T_0}\right)$ is determined by the evaporation

heats of the ions from surface $1'$. Thus one finds $N/N_1 = \frac{(V-\varphi_w)(T_0 - T_{01})}{T_{01}(\varphi_w - \varphi_1)}$

$\frac{T}{T_{01}}$, where φ_w is the work function of a pure tungsten surface, which is

correct provided that $\varphi_{kmin} + \varphi \gg kT$, where φ_{kmin} is the minimum of the local work function. In order to verify these theoretical results experimentally, a cylindrical capacitor was placed into an unsoldered bulb filled with Cs vapor and containing a tungsten thread, 100 microns in diameter and 14 cm long, which was fastened along its axis. Ions emitted from the central portion of the thread were collected by the measuring cylinder. The bulb was provided with taps containing metallic Cs and a Ba-Ti getter. The temperature of the thread was measured with an optical micropyrometer; at low temperatures, it was determined from the filament current. The temperature of the first thermostat was kept above that of the second which was used to calculate the vapor pressure of Cs. The ion current was measured with a mirror galvanometer of a sensitivity limit of $3 \cdot 10^{-10}$ a/scale unit. The temperature dependence of the ionization of Cs on W was studied

Card 3/84

34211

S/057/62/032/002/012/022
B124/B102

Dependence of the ...

in a Ca vapor pressure range of $9 \cdot 10^{-9}$ to $5 \cdot 10^{-4}$ mm Hg, with a change in the threshold temperature from 880 to 1450 K. Since the error due to the omission of the change in the degree of adsorption is about 6%, Eq. (6)

may be re-written as $\ln n \approx L + \frac{1}{k} \left(\frac{1}{T_0} - \frac{1}{T_{01}} \right)$. Professor N. I. Ionov,

Professor A. I. Gubanov, and N. D. Potekhina are thanked for discussion.

There are 5 figures and 12 references: 5 Soviet and 7 non-Soviet. The four most recent references to English-language publications read as follows: W. B. Nattingham, Proc. of the Fourth International Conference on Ionization Phenomena in Gases (Uppsala, 17 - 21 August, 1959), 1, 486, 1960. R. C. Evans, Proc. Roy. Soc. A139, 604, 1933; J. B. Taylor, J. Langmuir, Phys. Rev. 44, 423, 1933; T. J. Killian, Phys. Rev. 27, 578, 1926.

ASSOCIATION: Fizikio-tekhnicheskiy institut im. A. F. Ioffe AN SSSR, Leningrad (Physicotechnical Institute imeni A. F. Ioffe, AS USSR, Leningrad)

SUBMITTED: June 17, 1961
Card 4/54

X

37071
S/057/62/032/004/017/017
B173/B102

26.1640 26.2312
AUTHORS:

Zandberg, E. Ya., Ionov, N. I., Paleyev, V. I., and
Tontegode, A. Ya.

TITLE:

Determination of thermionic emission constants from energy
distribution curves for thermoelectrons and positive ions

PERIODICAL: Zhurnal tekhnicheskoy fiziki, v. 32, no. 4, 1962, 503 - 516

TEXT: For plane and coaxially cylindrical electrodes with homogeneous
work function, expressions ("ideal" retardation curves) for the emission
current are derived on the assumption of Maxwellian energy distribution,
and extended to electrodes with inhomogeneous work function (experimental
retardation curves). As the areas of different work function (spots)
cannot be localized, only a qualitative consideration is possible. The con-
tact potential field of the spots is regarded first as being compensated
by the external field (independent emission of individual spots) and then
as not being compensated. The mean work function of the cathode was deter-
mined from the saturation current at given temperature. An apparent con-
tact potential difference, which can be determined from the experimental

Card (1/2)

L 13044-63 INT(1)/EWG(c)/EMP(q)/EWT(m)/BDS/ES(w)-2 AFPTC/ASD/
ESD-3/SSD Pz-4/Pab-4 AT/JD/IG/IJP(C)

ACCESSION NR: AP3001337

S/0057/63/033/006/0713/0717

AUTHOR: Zandberg, E. Ya.

TITLE: Surface ionization on metals in an electric field

SOURCE: Zhurnal tekhnicheskoy fiziki, v. 33, no. 6, 1963, 743-747

TOPIC TAGS: surface ionization, field desorption, field ion emission

75
72

ABSTRACT: An improved expression is derived for the degree of surface ionization in an electric field as a function of the field strength. The work was undertaken in view of the importance of this relation not only for the theory of surface ionization, but for field desorption and ion emission as well, and because a rigorous derivation had not previously been given. The derivation follows the statistical method employed by L.N. Dobretsov (Elektronnaya i ionnaya emissiya. Gos. izd. tekhn-teor. literatury, 1952), but account is taken of the short range forces between the adsorbed atom and the surface (van der Waals forces, chemical forces, etc.). For the case of a very strong field, the result differs from that obtained for this case by Dobretsov (ZhTF, 23, 417, 1953) by the presence in the exponent of a term taking account of the short range forces and the absence of the term eEx , where E is the field strength and x is the critical charge exchange distance. The author considers it likely that in the desorption of barium from

Card 1/2

27

L 13044-63

ACCESSION NR: AP3001337

21 tungsten points the deviation from the Schottky type dependence noted by R. Gomer (J. Chem. Phys., 31, 341, 1959) is explained better by his new formula than by the assumption of the formation of doubly charged barium ions. "I thank Professor N. I. Ionov for a discussion of the questions treated in this article." Orig. art. has: 20 formulas and 2 figures. 3

ASSOCIATION: Fiziko-tekhnicheskii institut im. A. F. Ioffe AN SSSR Leningrad (Physical-Technical Institute, AN SSSR)

SUBMITTED: 10Nov62

DATE ACQ: 01Jul63

ENCL: 00

SUB CODE: 00

NO REF SOV: 007

OTHER: 008

Card 2/2

L 19018-65 EWD(j)/EWI(l)/EWP(a)/EWT(m)/EPP(a)/EPR/EPA(w)-2/ERG(t)/T/RWP(t)/
EWP(b)/EWI(m)-2 Pq-l/Pr-l/Pg-l/Pab-10 IJP(c)/ASD(m)-3/AS(mp)-2/ASD(d)-5/
ESD(gs) WH/WN/JD/JG

ACCESSION NO: AP4049048

S/0057/64/034/011/2048/2055

AUTHOR: Zandberg, E.Ya. Paityav, V.I.

TITLE: Surface ionization of In, K, Rb and Cs atoms and CsCl, RbCl and KCl molecules, with formation of positive ions

SOURCE: Zhurnal tekhnicheskoy fiziki, v.34, no.11, 1964, 2048-2055

TOPIC TAGS: surface ionization, graphite, indium, potassium, rubidium, cesium, potassium compound, rubidium compound, cesium compound

ABSTRACT: The ionization of In, K, Rb, Cs, CsCl, RbCl and KCl on a graphite surface was measured at temperatures up to 2300°K. Graphite was chosen for investigation because its electrical properties are intermediate between those of metals and semiconductors. Spectroscopic grade graphite was employed in the form of 60 x 1.2 mm strips from 200 to 700 micron thick, requiring up to 350 watts for heating. The temperature was measured with an optical pyrometer, and with a thermocouple at the lower temperatures. The thermionic emission of the graphite was stable, with a work function within about 1% of 4.46 V, after 3 hours heating at 2400°K. The atomic and molecular beams were produced by evaporation from a fused quartz oven and

1/3

L 19018-65

ACCESSION NR: AP4049046

were directed through slits onto the graphite surface. The positive ions leaving the surface were detected with a low resolution mass spectrometer capable of resolving Rb^{85} and Rb^{87} . A vacuum of 3×10^{-7} mm Hg was maintained during the measurements. The surface ionization coefficients of the metals except potassium were independent of temperature above the threshold; the ionization coefficient of potassium decreased somewhat with increasing temperature. The behavior of the graphite surface with respect to the ionization of alkali metals was very similar to that of metal surfaces. The metal ion currents from the chloride molecules continued to increase with increasing temperature. In the case of CsCl, a plot of the logarithm of the ion current versus the reciprocal temperature consisted of two straight segments, of which that for the higher temperatures had the greater slope. The enhanced ion current at the higher temperatures is ascribed to increased dissociation of the molecules. The relation between ion current and temperature is discussed in terms of the theory of surface reactions on porous materials, and it is concluded that the difference between the heat of dissociation on the surface and the heat of sublimation from the surface lies between 0.8 and 1.0 eV for the different salts. The authors thank Prof. I. I. Ivanov and N. D. Potekhina for discussing the results of the work." Orig. art. has 4 formulas and 9 figures.

2/3

L 19018-65

ACCESSION NR: AP4049048

ASSOCIATION: Fiziko-tekhnicheskij Institut im.A.F.Ioffe AN SSSR, Leningrad (Physi-
cotechnical Institute, AN SSSR)

SUBMITTED: 10Mar64

ENCL: 00

SUB CODE: NP, SS

NR REF SOV: 010

OTHER: 004

3/3

5/2057/85/031/000

AUTHOR: Zandberg, E. Ya ; Tentegode, A. Ya.

TITLE: Some thermoelectric properties of Re...

... 1970, 325-331

... rhenium, indium, calcium, silver, ...

ABSTRACT: The thermoelectric emission of Re and the ionization of In, Ca, Ag and ... on a rhenium surface were measured. The measurements were undertaken because of the technical importance of Re for electronic applications stemming from its low ...

... and was surrounded by two grids for suppression of secondary electron emission. The collector was provided with three slits, two to admit atomic beams from two ... and a third to permit a small fraction of the ion current to enter a mass ...

Card 1/3

I-33179-65

NO. 1000 0000

OTHER: 010

Card 3/3

13
Emission of positive and negative molecular ions from heated surfaces

Source: Zhurnal Tekhnicheskoy Fiziki, v. 35, no. 3, 1965, 562-567

FLUX OF A MASS-ANALYZER. THE PRESSURE OF THE RESIDUAL GASES IN THE DEVICE FLUCTUATED

Card 1/3

ment as a function of temperature followed a bell-shaped curve with a maximum at about 1500K. It fell to near zero at 1600-1700K. With a further increase in temperature, the emission of ions increased with temperature.

in correct isotropic ratio. The tantalum filament, however, displayed a different picture. The emission started about 1600K. At temperatures above 1600K, W^{+} and Cl^{-} were the

L 39504-65

ACCESSION NR: AP5007308

... in the 0-1000 temperature range. The atom ionization potentials V (for $m/e = 29$) were $V_{29} = 6.3$ to 7.3 v; $V_{44} = 5.8$ to 5.2 v; $V_{55} = 6.2$ to 6.3 v; $V_{66} = 5.9$ to 5.4 v; and $V_{77} = 6.0$ to 6.4 v. The cross section σ ...

... indicates that the atom ionization potential of this compound is equal to or lower than the work function value of 5.1 v. This illustrates that many organic molecules and radicals possess a high degree of thermal stability, an affinity to the electron, a relatively low potential of ionization, and the capability of forming positive and negative ions...

NO REF SOV: 005

OTHER: 002

ATT PRESS: 321

Card 3/3 10

L 54754-65 ENT(1)/EPA(s)-2/ENT(m)/EPF(c)/EPF(n)-2/EPA(w)-2/T/EPD(+1)/EPD(-1)

AUTHOR: Zandberg, E.Ya.; Terterova, A.Ya.

TITLE: Surface ionization of Li^A, Na^A, K^A and Cs^A atoms and LiCl^A, NaCl^A

Surface ionization, alkali metal, alkali halide, rhenium, lithium, sodium, potassium, cesium, chloride

ABSTRACT: The surface ionization currents of Cs, CsCl, K, KCl, Na, NaCl, Li and LiCl on polycrystalline Re were measured at temperatures from the ionization threshold to 2000 K. The measurement

Card 1/3

0 04706-00

ACCESSION NR: AF5015637

generative and experimental technique elsewhere (ZhTF 34:309, 1964).

The ionisation took place on the surface of a 100 μ diameter wire which was subjected to the preliminary heat treatment described in the reference cited above. The residual gas pressure was 2×10^{-7} mm

measured in the chamber. The results discussed in detail. It was found that above a certain critical temperature the surface ionization current of an alkali metal shows the same temperature dependence as that of its chloride. This critical

Card 2/3

ACCESSION NR: AF0015667

V. Starodubtsev (Trudy Fiz.-tekh. Inst. AN Uzb.SSR 2,6,1948), and the theories were found to be able to account for the data. The temperature dependences of the surface ionization currents from the alkali metal atoms were in qualitative agreement with the predictions of

cluded that phenolic adsorption processes considerably increase the surface ionization currents. The authors of this paper. 5 figures and 6 figures.

ASSOCIATION: Fiziko-tekhnicheskii institut im.A.F.Ioffe AN SSSR.

L 59350-65 EIT(I)/EWP(G)/EIT(M)/EWP(I)/EPP(A) L/PAC(M)/EPA(M) L/T/EWP(A)/EWP(M)

AUTHOR: Mandberg, F. Ya.; Paleyev, V. I.

TITLE: Inherent thermionic emission of lanthanum hexaboride and surface ionization of cesium atoms on it

SOURCE: Zhurnal tekhnicheskoy fiziki, v. 35, no. 7, 1965, 1308-1311

TOPIC TAGS: thermionic emission, inherent thermionic emission, surface ionization, cathode, surface ionization, surface activation, atom

ABSTRACT: An investigation was made of the surface ionization of Cs atoms on a cathode made of LaB6. The use of compressed cathodes made it possible to exclude the influence of backing. Mass-spectrometric methods were used to permit observation of emission of the cathode and to make it possible to measure the temperature dependence of the thermoelectron current for use in determining the thermoelectron work function from the same surface region from which the ion current was

Card 1/3

AP5018313
ACCESSION NR: AP5018313

The electron and ion currents were emitted by a

raising the temperature. The following figures were drawn: 1) The activated cathode probably has foreign inclusion and nonactivated surface sections on which the work function may exceed 4.9 eV. 2) At $T > 1400K$, simultaneously with the rise of Ca^+ current, the current of inherent thermoemission of LaO^+ also appears and at $T \sim 1600K$ the current of La^+ appears. Since the ionization potential of lanthanum $\phi_{La} = 5.61 eV$, it is probable that the main part of the lanthanum atoms evaporating from the surface are desorbed in the atomic state and not in the ionic. The intensity of the La^+ and LaO^+ lines depends on the pressure of the residual gases in the instrument. With increased pressure the intensity of the LaO^+ line increases. The evaporation of La and LaO can lead to a change of the ion current when the temperature is increased. ORIG. ACC. NO. [52]

L 571044

Leningrad (Physicotechnical Institute, AM 888R)

SUBMITTED: 1988p04

ENCL: 00

SUB CODE: E1, EA

NO REF SOV: 000

OTHER: 001

ATD PRESS: 1042

AR

L 2303-66 ENT(1)/ENT(n)/ETC/EPF(n)-2/ETD(n)/EHA(d)/EPA(w)-2/T/EIP(t)/ZAP(t)
ACCESSION NR: AF5020741 IJF(c) JD/JC/AT UR/0057/65/035/008/1501/1503

AUTHOR: Zandberg, E. Ya.; Tomtegode, A. Ya.

TITLE: Thermionic emission constants of molybdenum, tantalum, and tungsten wires

SOURCE: Zhurnal tekhnicheskoy fiziki, v. 35, no. 8, 1965, 1501-1503

TOPIC TAGS: work function, thermionic emission, surface ionization, polycrystal, molybdenum, tantalum, tungsten

ABSTRACT: The authors have measured the thermionic and surface ionization work functions of 100 to 150 micron diameter polycrystalline Ta, Mo, and W wires with an apparatus that they have described elsewhere (ZhTF, 35, 149, 1965). Tungsten was measured as a control. The thermionic work functions were derived from Richardson curves and the surface ionization work functions were determined from the temperature dependence of the surface ionization current of indium. The temperatures were measured with an optical micropyrometer and were corrected to true values by means of published tables. The Mo, Ta, and W wires were annealed at 2400°, 2600°, and 2700°K, respectively. This heat treatment was sufficient to stabilize the thermionic emission properties and to eliminate self-emission of impurity alkali metal ions. The residual gas pressure was approximately 10⁻⁷ mm Hg.

Card 1/2

L 2303-66

ACCESSION NR: AP5020741

4

The measured thermionic work functions of Ta, Mo, and W were 4.33, 4.33, and 4.18 V, respectively; the corresponding surface ionization work functions were 4.88, 5.02, and 5.14 V. The probable errors of these work functions range from 0.03 to 0.07 V. The values found for the work functions differ considerably from those reported by Kh.Khadzhimukhamedov and G.N.Shuppe (Izv. AN Uzb. SSR, Ser. fiz.-mat. nauk, 2, 55, 1957). This discrepancy is ascribed to the use by Khadzhimukhamedov and Shuppe of easily ionized alkali metals to measure the surface ionization work functions. Ta and (from earlier work) Re wires have much more stable thermionic emission properties than Mo or W wires. Orig. art. has: 1 formula, 1 figure, and 1 table.

ASSOCIATION: Fiziko-tekhnicheskii institut im. A.F.Ioffe AN SSSR, Leningrad
(Physico-technical Institute, AN SSSR) 44, 55

SUBMITTED: 21Jan65

ENCL: 00

SUB CODE: SS, EM

NR REF SOV: 005

OTHER: 000

Micro wires

EVR

Card 2/2

L 2304-66 EWT(m)/EPF(c)/EMA(a)/T/ JD/JW
ACCESSION NR: AP5020742

UR/0057/65/035/008/1504/1515

AUTHOR: Zandberg, E. Ya.; Ionov, N. I.; Tontegode, A. Ya.

TITLE: Mass spectrometric determination of the heat of vaporization of atoms and positive ions in sublimation of polycrystalline rhenium, tungsten, tantalum, and molybdenum

SOURCE: Zhurnal tekhnicheskoy fiziki, v. 35, no. 8, 1965, 1504-1515

TOPIC TAGS: heat of sublimation, vacuum sublimation, atom, ion, work function, mass spectrometer, rhenium, tungsten, tantalum, molybdenum

ABSTRACT: The authors have directly determined the vaporization energies L_a and L_i of atoms and ions from polycrystalline surfaces of the refractory metals Re, W, Ta, and Mo. These measurements are said to be the first direct determinations of L_i . The samples were 45 mm long 100 to 150 micron polycrystalline wires located on the common axis of three cylindrical grids to which appropriate potentials could be applied. Positive ions leaving the surface of the sample were extracted by negative potentials on the cylindrical grids and their flux was measured with a mass spectrometer. When atoms were being investigated, the ions were excluded by

Card 1/3

L 2304-66

ACCESSION NR: AP5020742

positive potentials on the grids. The atoms diffused into a chamber where they were ionized by an electron beam and the resulting ion flux was measured with the mass spectrometer. The use of a mass spectrometer to determine the composition of the sublimed gas is considered essential. When the residual gas pressure in the apparatus was 10^{-7} mm Hg, only atoms and atomic ions were found; when the pressure was $(1-5) \times 10^{-6}$ mm Hg, oxide molecules and molecular ions were also present. The temperature of the sample was determined with an optical micropyrometer, and the position of the sample and the electrode system was monitored by measuring the surface ionization of indium. The samples were subjected to a prolonged preliminary heating at the highest temperature employed in the measurements. The vaporization energies were determined from the temperature dependences of the fluxes. The thermodynamic theory of this determination is derived and the type of average over the different crystallographic faces to which it leads is discussed. It is not possible directly to test the consistency of the data by means of the Schottky relation $L_a - L_i = e(W - V)$, where W is the work function and V is the ionization potential, because the different quantities are averaged differently. The question of averages is discussed at some length, and inequalities are derived that the measured values of L_a , L_i , and W should (and do) satisfy. The statistical error of the vaporization energy measurements was approximately 5%. A systematic error as great as 4% is possible in the T_0 and T_a temperature measurements. The values ob-

Card 2/3

L 230h-66

ACCESSION NR: AP5020742

tained for L_a are compared with those found by other authors, and some discrepancies are discussed. "The authors are grateful to N.D.Potekhina for participating in a discussion of the work." Orig. art. has: 24 formulas, 5 figures, and 1 table

ASSOCIATION: Fiziko-tehnicheskii Institut im. A.F.Ioffe AN SSSR, Leningrad
(Physico-technical Institute, AN SSSR)

44.55

SUBMITTED: 08Feb85

ENCL: 00

SUB CODE: KP, IS

NR REF SOV: 009

OTHER: 012

Card 3/3

bel

L 10674-65 EWT(1)/EWT(m)/ETC/ENG(m)/I/EWP(t)/EWP(b)/EWA(m)-2 IJN(c) JD/AT
ACC NR: AP5028326 SOURCE CODE: UR/0057/65/035/011/2092/2098 172
836
B

AUTHOR: ^{44,55} Zandberg, E. Ya.; ^{24,55} Paleyev, V.I.

ORG: ^{44,55} Physico-technical Institute im. A.F.Ioffe, AN SSSR, Leningrad (Fiziko-
tehnicheskii institut AN SSSR)

TITLE: ^{21,44,55} Surface ionization of atoms on silicon

SOURCE: Zhurnal tekhnicheskoy fiziki, v. 35, no. 11, 1965, 2092-2098

TOPIC TAGS: surface ionization, crystal surface, semiconductor crystal, silicon,
alkali metal, indium, work function, thermionic emission, *atom, particle beam*

ABSTRACT: ^{21,44,55} The thermoelectronic emission from and the ionization of Cs, K, Na, Li,
and In on a (111) face of an n-type semiconducting silicon crystal (resistivity,
150 ohm cm) has been measured at temperatures from 1100 to 1600°K. The measurements
were undertaken because surface ionization on semiconductors has not been thoroughly
investigated and the measurements for silicon surfaces of N.G.Ban'kovskiy and E.N.
Formozov (Izv. AN SSSR, seriya fizich., 28, 1522, 1964) are questionable, owing to
the high atomic beam intensities that were employed. The 30 x 2 x 0.4 mm³ silicon
crystal was etched with a mixture of HNO₃ and HF and washed with boiling water; it
was mounted on tantalum and heated electrically during the measurements. The temper-
ature was measured with an optical pyrometer, the brightness temperatures being re-
duced to thermodynamic temperatures with the aid of the data of F.G.Allen (J.A.pl.

UDC: 537.77

Card 1/3

L 10674-66

ACC NR: AP5028326

Phys., 28, 1510, 1/37). The Cs atomic beams were obtained by reduction of the chloride with calcium; the remaining atomic beams were obtained by evaporating the metals. An iron oven was employed for the Li evaporation, and fused quartz ovens were used for the other metals. The atomic beam intensities at the crystal ranged from 10^7 atom/cm²sec for Cs and K to 5×10^9 atom/cm² sec for In. The silicon crystal was outgassed and annealed at 1550-1600°K before the measurements. During the anneal the room temperature resistivity of the silicon crystal decreased by a factor 2 and thereafter remained stable. The length of entrance slit of the mass spectrometer was 1 mm; ions were accordingly admitted only from the central portion of the crystal where the temperature was uniform. The pressure in the stainless steel chamber was maintained below 10^{-7} mm Hg during the measurements. The thermoelectronic work function, derived from Richardson plots, was found to be 4.94 ± 0.05 V; it was independent of the field strength at the crystal surface over the range from 75 to 1250 V/cm. No temperature dependence of the surface ionization currents of Cs and K was found in the temperature range investigated; the surface ionization thresholds for these metals occur at lower temperatures. The surface ionization currents of Na, Li, and In varied with temperature in accord with the Saha-Langmuir equation, and all three metals gave the same value 4.9 V for the work function, within the experimental error of less than 0.1 V. Possible reasons are discussed for the large discrepancy between the thermoelectronic and surface ionization work functions and no satisfactory explanation is found. Further investigation is necessary. The authors

Card 2/3

L 10674-66

ACC NR: AP5020326

thank N.D. Potekhin and N.I. Ionov for discussing the work. Orig. art. has:
1 formula and 4 figures. 6

SUB CODE: 20

SUBM DATE: 29Mar65/

ORIG. REF: 007 ORN REF: 006

Card ^{nj} 3/3

ACC NR: AP7008115

SOURCE CODE: UR/0020/67/172/004/0835/0888

AUTHOR: Zandberg, E. Ya.; Rasulev, U. Kh.; Shustrov, B. N.

ORG: Physicotechnical Institute im. A. F. Ioffe, Academy of Sciences, SSSR (Fiziko-tokhnicheskii institut Akademii nauk SSSR)

TITLE: Thermionic emission of positive ions of certain organic compounds from tungsten oxides

SOURCE: AN SSSR. Doklady, v. 172, no. 4, 1967, 885-888

TOPIC TAGS: thermionic emission, tungsten compound

ABSTRACT: Experiments were carried out on thermionic emission from tungsten oxides in a mass spectrometric apparatus in the presence of various organic compounds at 10^{-5} mm Hg. The following compounds produced thermions: diethylamine, phenol, aniline, trimethylhydrazine, acetone peroxide, several amino acids, and also acetic and formic acid. Most attention was devoted to the ionization of the first four compounds. The spectra of thermionic emission from tungsten oxides (at $T \leq 1100^\circ\text{K}$) and tungsten (at $T \geq 2000^\circ\text{K}$) are tabulated. With the exception of aniline, ions representing products of surface reactions were observed in all cases. The results are in accord with previously advanced hypotheses on the formation of thermions by both catalytic dissociative ionization and formation of "heavy" ions in chemical surface reactions. The temperature dependence of thermionic currents from tungsten oxide

Card 1/2

UDC: 537.58 + 543.51

ACC NR: AP7008115

surfaces was determined; the bell-jar shape of the $I = f(T)$ curves obtained indicated the simultaneous occurrence of ionization and dissociation of the particles on the surface. In the case of aniline, the $I = f(T)$ function was exponential. It is noted in conclusion that the thermal ionization of organic compounds on the surface of solids may be used as a method of studying processes of heterogeneous catalysis. Authors thank N. I. Ionov for discussing the results and I. N. Bakulin for his assistance. The paper was presented by Academician Konstantinov, B. P., 13 Apr 66. Orig. art. has: 3 figures and 1 table.

SUB CODE: 07/ SUBM DATE: 11Apr66/ ORIG REF: 007/ OTH REF: 006

20/

2/2

L 34817-66 EWT(l)/EWT(m)/T/EWP(t)/ETI IJP(c) JD/JG/AT

ACC NR: APS018719

SOURCE CODE: UR 0057/66/036/006/0963/0980

AUTHOR: Zandberg, E. Ya.; Tontegodo, A. Ya.

ORG: Physicotechnical Institute im. A.F.Ioffe, AN SSSR, Leningrad (Fiziko-tokhnicheskii institut AN SSSR) 97
B

TITLE: Rhenium thermoemitters, a survey 21

SOURCE: Zhurnal tekhnicheskoy fiziki, v. 36, no. 6, 1966, 963-980

TOPIC TAGS: rhenium, thermionic emission, surface ionization, ion source, mass spectrometry, field emission, thermionic energy conversion, MELTING POINT, WORK FUNCTION, REFRACTORY METAL

ABSTRACT: In this survey article, which has a bibliography of 74 entries, the authors review the properties of rhenium with particular attention to its use as a thermionic emitter and as a medium for surface ionization and compare them with those of other refractory metals such as tungsten, molybdenum, and tantalum. The scope of the survey is indicated by the section and subsection headings: 1) Melting point; 2) Heat of vaporization and vapor pressure; 3) Crystal structure; 4) Mechanical properties; 5) Electric conductivity; 6) Chemical properties, a) Reaction with carbon, b) Reaction with nitrogen, c) Reaction with oxygen, d) Reaction with water, e) Reaction with Alundum; 7) Spectral emissivity; 8) Thermionic emission; 9) Surface ionization work function; 10) Surface ionization of alkali halide molecules; 11) Examples of

Card 1/2

UDC: 537.5

L 34817-66

ACC NR: AP6018719

applications, a) Surface ionization ion sources for mass spectrometers; b) Electron impact ion sources for mass spectrometers, c) Field emitters, d) Ionization gages, e) Energy converters. In the section on crystal structure there are also discussed the texture of polycrystalline rhenium and the use of thin rhenium films on substrates of other refractory metals. The melting point of rhenium is lower than that of tungsten and its work function is higher; rhenium is accordingly not always the most suitable material for applications requiring the highest possible thermionic emission. Rhenium however, combines a relatively low thermionic work function and a high surface ionization work function with advantageous mechanical properties, a high melting point, a low vapor pressure in the operating temperature range, and a chemical inertness that assures very stable operation. The authors predict that rhenium will find increasing use as thermionic emitters and surface ionization media in special electronic devices. Orig. art. has: 4 formulas, 12 figures, and 6 tables. [15]

SUB CODE: 20,11/ SUBM DATE: 23Dec65/
ATD PRESS: 5030

ORIG REF: 038/

OTH REF: 036

Card 2/2

L 45917-66 EWT(1) AT

ACC NR: AP6028620

SOURCE CODE: UR/9057/66/036/008/1459/1468

AUTHOR: Paleyev, V.I.; Karatayev, V.I.; Zandberg, E.Ya.

ORG: Physicotechnical Institute im. A.F.Ioffe, AN SSSR, Leningrad (Fiziko-tekhnicheskii institut AN SSSR)

TITLE: On the applicability of the Saha-Langmuir formula to the description of the temperature dependence of the positive ion current incident to surface ionization of atoms on silicon

SOURCE: Zhurnal tekhnicheskoy fiziki, v. 36, no. 8, 1966, 1459-1468

TOPIC TAGS: surface ionization, silicon single crystal, work function, thermionic emission, contact potential, Richardson equation, *ION CURRENT*

ABSTRACT: The authors have previously investigated the surface ionization of Na, Li, and In on a (111) face of a silicon single crystal (ZhTF, 35, 2092, 1965) and obtained from their results, with the aid of the Saha-Langmuir formula, the value 4.9 V for the work function of the (111) face of silicon. This value of the work function is much greater than the value 4.0 V obtained from Richardson plots. Possible hypothesized reasons for this discrepancy are discussed briefly and most are found to be unconvincing. To clarify this situation, measurements of the work function by different techniques were undertaken. The measurements were made on the (111) face of a p-type silicon crystal with a resistivity of about 1000 ohm cm. Contact potential work

Card 1/2

L 45917-66

ACC NR: AP8028620

functions were derived from retarding potential curves of the thermoelectron emission current and of the positive ion current from surface ionization of cesium by comparison with analogous curves obtained with tungsten and graphite emitters. The thermoelectron emission current was also measured, and work functions were derived both from Richardson plots and from the total emission current. The retarding potential curves showed that both the electrons and the positive ions had Maxwellian distributions with temperatures equal within the experimental error of 100°C to the temperature of the emitter. The contact potential work functions derived from the retarding potential curves were independent of temperature over the investigated range from 1100 to 1600°K and were equal, within the experimental error of about $\pm 0.1\text{ V}$, to the value previously obtained with the aid of the Saha-Langmuir equation from the temperature dependence of the surface ionization. The total emission current work function was equal to the contact potential work function of 1600°K but had a temperature derivative of $6 \times 10^{-4}\text{ V/degree}$. The Richardson plot gave the previous low value for the work function ($4.07 \pm 0.05\text{ V}$). From the agreement between the contact potential and surface ionization work functions it is concluded that the Saha-Langmuir equation correctly describes the temperature dependence of the surface ionization of Na, Li, and In on silicon. Possible reasons for the low value of the Richardson plot work function are briefly discussed, but none is selected as the most likely. The authors thank N.I. Ionov and H.D. Potekhin for discussions. Orig. art. has: 5 formulas, 6 figures and 1 table.

SUB CODE: 20

SUBM DATE: 03Jan66

ORIG. REF: 011 OTH REF: 008

Card 2/2 mjs