

SHVACHKIN, Yu.P. [translator]; STEPANENKO, B.N., red.

Phosphates of carbohydrates (from "Quart.Revs." 71, 61-85, 1957)
A.G. Foster, U.G. Overend. Usp. khim. 27. no.7:891-914 J1 '58.
(MIRA 11:9)

(Carbohydrates)	(Phosphates)
(Foster, A.G.)	(Overend, U.G.)

20-119-3-41

AUTHORS: Stepanenko, B. N., Bobrova, L. N.
TITLE: On ZSC - a New "Yeast" Stimulant of Cardiac Activity
(O ZSC - novom "drozhzhevom" stimulyatore serdechnoy
deyatelnosti)

PERIODICAL: Doklady Academy Nauk SSSR, 1958, Vol. 119, Nr 3,
pp. 547-550 (USSR)

ABSTRACT: The preparation Sodium DFF increases the amplitude of the cardiac contractions in frogs and maintains for several hours if it was used in the case of a heart with an activity to a great extent reduced (perhaps by perfusion with Ringer's solution 1,5-2 for days). Other phosphorylated hexoses have a much lower and quickly fading effect. A stronger effect of Sodium DFF compared to other sugar phosphates, became intelligible, since fructose diphosphate which is the phosphate which is to the greatest extent dicyclisated and thus best prepared for the dissociation of the carbon chain in the glycolytic process (ref 2). Simultaneously the extremely great difference of efficiency between the sugar monophosphates and the fructose diphosphate admits the assumption that Sodium DFF

1/4

On ZSC - a New "Yeast" Stimulant of Cardiac Activity

20-119-3-43/65

contains perhaps any highly active admixtures. Beside the known ingredients (ref 3) Sodium DFF contained phosphorus glyceric acid and in some series 6-fructose phosphates according to the paper chromatography. The effect of these admixtures in small quantities on the heart is not worth mentioning. Therefore other highly active admixtures are sought in the preparation in question. Sodium DFF solution was treated with activated charcoal in the case of different pH-values, the adsorbed admixtures were eluted under various conditions, the extracts were studied chromatographically and controlled biologically (by action on the heart). After longer work the attempt, to isolate a substance which was highly active (in a concentration of approximately 1:100000) and homogenous, was successful. The authors denoted it Zymostimulator cordis, in short ZSC, till the exact detection of its structure. After this substance had been obtained in chromatographically pure state its chemical structure could be detected. Then the isolation of ZSC from fructose diphosphate and from the yeast fermentation mixtures is given with the biological

Card 2/4

On ZSC - a New "Yeast" Stimulant of Cardiac Activity

20-119-3-43/65

effect. The detection of uracil in ZSC was carried out by means of the investigation of the absorption spectrum of the ZSC solution in ultraviolet light. This spectrum has a selective absorption with a maximum at 260 m μ (figure 1) which is characteristic of adenylyl- and uridine compounds. Figure 1 shows that the mentioned maximum vanishes in consequence of a treatment with bromine water (ref 6). This means that the compound in question is a uracil derivative. Furthermore the chemical nature of ZSC was proved by means of hydrolysis up to the liberation of the pyridine base in a 45 % HClO₂ for 2 hours. By means of chromatographing a spot with R_f = 0,61 was found in the system of the solvent isopropanol-alcohol- 10 n HCl (21:3:3). Uracil was chromatographed in parallel with the hydrolysate as well as adenine and guanine, the Uracil having R_f = 0,62. Pentose was determined with orcinol according to ref 7. It is bound here to the pyrimidine base. Finally a ratio of 1:2 was proved between the not acid-proof phosphorus and the total phosphorus. Thus ZSC can be considered as uridine derivative. It is also possible that the terminal radical of the

Card 3/4

~~STEPANENKO, B.N.~~, otv.red.; ROZENFEL'D, Ye.L., red.; KUZNETSOV, A.A., red.;
SAVVATEYEVA, T.I., red.izd-va; POLYAKOVA, T.V., tekhn.red.

[Carbohydrates and their metabolism in animal and plant organisms;
materials of the conference held Jan.28-30, 1958] Uglivody i ugle-
vodnyi obmen v zhivotnom i rastitel'nom organizmakh; materialy
konferentsii, sostoiavsheisia 28-30 ianvaria 1958 g. Moskva, 1959.
270 p. (MIRA 12:11)

1. Akademiya nauk SSSR. Laboratoriya fiziologicheskoy khimii.
2. Laboratoriya fiziologicheskoy khimii Akademii nauk SSSR, Moskva.
(for Stepanenko, Rozenfel'd).
(Carbohydrate metabolism)

STEPANENKO, B.N.; KUZNETSOV, A.A.

Chromatographic study of some sugar phosphates [with summary in English]. *Biokhimiia* 24 no.1:25-32 Ja-F '59. (MIRA 12:4)

1. Laboratory of Physiological Chemistry, Academy of Sciences of the U.S.S.R., Moscow.

(FRUCTOSE PHOSPHATES)

(CHROMATOGRAPHIC ANALYSIS)

SOV/14

5 (3)
AUTHOR:
TITLE:

Stepanenko, B. N. (Moscow)

On Several Achievements in the Field of the Research of Carbohydrates (O nekotorykh dostizheniyakh v oblasti izucheniya uglevodov)

Uspekhi khimii, 1959, Vol 28, Nr 5, pp 521 - 546 (USSR)

PERIODICAL:
ABSTRACT:

The present survey deals above all with papers, written during the last 5 - 6 years. Besides purely chemical problems also biological chemical problems are taken into consideration. At the beginning the survey deals with papers on the determination of absolute stereochemical configuration of simple substances, related to carbohydrates. As the configuration of tartaric acid the sugars was compared with that of tartaric acid the work recently carried out in this direction by means of the X-ray method is of particular interest (Refs 3-5). The data obtained showed that the structural formulas assumed under certain conditions already in E. Fisher's papers for levorotatory and dextrorotatory tartaric acids correspond to their absolute structure (Fig 1). After the discovery of the new enzyme mutarotase (Ref 7) the investigation of mutarotation is bound to gain particu-

Card 1/6

...one structure
...years (Refs 1,8,9).
...in form of various con-
...ormations are applied to
...the investigation of sugars and their de-
...sugars supplied valuable material on their
...On the other hand it is also possible to explain
...process of numerous chemical reactions by the
...characteristics of conformation. During the past years it has
...possible to generate a number of stable preparations of the sodium salt of fructose di-
...sugar, in particular ketose phosphates. The method of prepara-
...phosphate (sodium DPhF) (Ref 26) worked out by the author is
...worth mentioning. The outstanding role of sugar phosphates in
...many biological processes is due to at least two reasons: to
...the energetic (Ref 27) and to the structural-chemical (Ref 28)
...one. The reactions of the transition of a part of the phosphate
...molecules in form of an "active" glycol aldehyde and the "active"

Card 2/6

On Several Achievements in the Field of the
Research of Carbohydrates

SOV/74-28-5-2/7

dioxyacetone which were developed during the past years are of outstanding importance for the understanding of the role played by the phosphates in the course of biochemical processes. The first reaction takes place by means of transketolase (Ref 29), the second with the aid of transaldolase (Ref 30). In this connection it is important to point out the recently discovered breaking of the hydrocarbon chain of sugar phosphates which proceeds under the splitting off of acetyl phosphate (Ref 34). In addition to the already known reactions the discovery of this new reaction of "phosphodesmolysis" provides a more comprehensive understanding of the carbohydrate transformations under biological conditions. On the basis of papers (Refs 36-38) it was found that beside glycolysis there is a new process of carbohydrate decomposition which Engel'gardt called the aatomic or oxidative process (Refs 39-42) (Fig 3). Apart from the glycolytic and aatomic process of the decomposition of glucose, in 1952 a third type of the decomposition process was discovered to take place in microorganisms, sometimes named after the discoverers Entner and Doudoroff (Ref 44). Several papers (Refs 45-47) dealt with the clarification of the inter-

Card 3/6

On Several Achievements in the Field of the
Research of Carbohydrates

SOV/74-28-5-2/7

mediate stages of this process. The new type of decomposition is supposed to be of great importance and to occur not only in microorganisms. Saccharin phosphates play an important role (Ref 51) (Fig 4) in photosynthesis besides their part in synthetic processes (Ref 50). Another extremely important field of chemistry and biochemistry of the carbohydrates are the glycosides, above all the O- and N-glycosides. Recently, a large amount of natural O-glycosides was separated and their structure could be determined. In this connection very peculiar monosaccharides were discovered exhibiting a peculiar structure as well as other peculiarities, among them ramified chains. After 1950 special attention was paid to new groups of N-glycosides of phosphorylated sugars which are free nucleotides (Refs 58-60). The presence of "makroergicheskiy" phosphate bonds in nucleoside polyphosphates causes their high activity in biological processes and in particular their taking part in a number of reactions of phosphorylation. Apart from these general traits coenzymes apparently exercise a number of specific functions (Refs 72-79). Recently the author succeeded in separating an uridin stimulant of cardiac action (ZSC - zymostimulant cordis)

Card 4/6

On Several Achievements in the Field of the
Research of Carbohydrates

SOV/74-28-5-2/7

from a yeast fermentation mixture and the preparation of the sodium salt of fructose diphosphate (Refs 80-81). Nucleotide polyphosphates may not only serve as initial products for the biosynthesis of nucleic acids, they also guarantee the process of the elementary reactions of metabolism. There is good reason for the assumption that the production and use of nucleotide polyphosphates will be of outstanding importance in future chemotherapy. Taking into account the difficulties arising in the chemistry of polysaccharides, the success achieved in this field during the past twenty years is simply amazing. Only recently it was possible to clarify the structural type of many highest homopolysaccharides as well as the decomposition processes and the biosynthesis of most important polysaccharides. A detailed investigation of all these problems is not possible in this paper (Refs 87-89). The investigations of amyloses (Refs 90-91), glycogen (Refs 92-107), dextran (Ref 108), the achievements in the field of the chemistry of cellulose (Refs 109-112) are mentioned as well as a paper on chitin (Ref 113). Furthermore, the papers on the investigations of the biological

Card 5/6

On Several Achievements in the Field of the
Research of Carbohydrates

SOV/74-26-5-2/7

decomposition and the biosynthesis of homopolysaccharides are dealt with (Refs 114-130). During the past years great successes were achieved in the field of the chemistry of heteropolysaccharides. In this connection special emphasis is to be laid upon the mucopolysaccharides (Refs 133-137). Some of their most important representatives are described: chondroitin sulfuric acid (ChS acids) (Refs 138-140). Recently it was confirmed that several ChS-acids exist. They are either contained in different sources, or in the same sources but in different quantity. Thus, ChS-acids - A, B and C - were separated (Table) (Refs 152-155). Recent investigations deal thoroughly with the research of mucoproteides (Refs 156-159). Among the achievements of the last five years are the findings in the field of the biosynthesis of mucopolysaccharides. It is, however, not possible to explain details so that in this connection only several data concerning the biosynthesis of hyaluronic acid (Ref 141) are given (Fig 5). However, not all problems of the biosynthesis of mucopolysaccharides have been solved. It is, therefore, to be assumed that these problems will be solved within the near future. There are 5 figures, 1 table, and 167 references, 48 of which are Soviet.

Card 6/6

BOBROVA, L.N.; STEPANENKO, B.N.

Effect on the cardiac muscle of phosphotriose, phosphoenolpyruvic acid and ZSC - uridine yeast stimulator of the cardiac function.
Biul.eksp.biol.i med. 47 no.8:71-75 Ag '59. (MIRA 12:11)

1. Iz Laboratorii fiziologicheskoy khimii (dir. - prof. B.N. Stepanenko) AN SSSR, Moskva. Predstavlena deystvitel'nyy chlenom AMN SSSR S.Ye. Severinym.

(NUCLEOSIDES AND NUCLEOTIDES pharmacol.)

(YEASTS extracts)

(TRIOSES pharmacol.)

(PYRUVATES pharmacol.)

(HEART pharmacol.)

17(3)

AUTHORS: Stepanenko, B. N., Bobrova, L. N. SOV/20-125-3-56/63

TITLE: A Comparative Investigation of the Effect of ZSC, UTP_h, UDP_h and ATP_h Upon the Contraction of the Cardiac Muscle
(K sravnitel'nomu izucheniyu deystviya ZSC, UTF, UDF i ATF na sokrashcheniye serdechnoy myshtsy)

PERIODICAL: Doklady Akademii nauk SSSR, 1959, Vol 125, Nr 3, pp 662-665 (USSR)

ABSTRACT: The authors succeeded in isolating a substance from a yeast fermentation mixture and a fructose diphosphate preparation which is capable of restoring the function of the tired cardiac muscle in very small concentrations. As long as its structure was not clarified the substance was called zymostimulator cordis (ZSC). Its structural components are: uracil, pentose and phosphoric acid. Half of the latter acid is unstable. Thus, ZSC is to be considered a uridin derivative, possibly near or identical with UDP_h (uridin diphosphate). The present paper deals with the comparative study of the effect of ZSC and uridin polyphosphates upon the heart. At an earlier time the opinion was expressed that UTP_h (uridin triphosphate) does not exert any direct effect, but favors the re-synthesis of adenosin triphosphate (ATP_h) on the action of a ferment of the type

Card 1/3

A Comparative Investigation of the Effect of ZSC, UTP_h, UDP_h and ATP_h Upon the Contraction of the Cardiac Muscle SOV/20-125-3-56/63

"Nudiki". ATP_h then acts upon the biological object. Comparative experiments with ZSC, UTP_h, UDP_h and ATP_h on a "whole" isolated heart served the purpose of "biologic identification" and detection of any possible specificity of the influence exerted by nucleotide polyphosphates. The experiment was made with an isolated heart of the grass frog *Rana temporaria*, which previously was exhausted by a Ringer's solution at 3-5° for as long as 24-48 hours. As had been hitherto the case (Refs 1, 2) ZSC at a concentration of 10⁻⁵ led to a strong increase of the cardiac contraction amplitude (Fig 1 A). The same also holds at 10⁻⁶ (Fig 1 B). The amplitude does not increase abruptly but gradually after the ZSC introduction. UDP_h (Figs 1 V and G) acts at exactly the same concentrations and in a similar way. Also UTP_h acts in a similar way (Fig 2 V). The characteristic and well-known 3-phase effect (Fig 3 A) appeared in experiments with ATP_h (10⁻⁵ - 10⁻⁶). Above results have only a provisional value. At any rate, they give evidence of a great similarity of the ZSC effect to that of uridin polyphosphates, especially of UDP_h. At the same time the authors determined a fundamentally

Card 2/3

A Comparative Investigation of the Effect of ZSC, UTP_h, UDP_h and ATP_h Upon the Contraction of the Cardiac Muscle

SOV/20-125-3-56/63

diverging type of effect of uridin polyphosphates and ATP_h, namely, the first three have a 1-phase effect, whereas ATP_h at equal concentration shows a 3-phase effect. Such a sharply marked specific effect scarcely allows the effect of uridin coenzymes to be explained by its transformation into adenine coenzymes. There are 3 figures and 14 references, 5 of which are Soviet.

ASSOCIATION: Laboratoriya fiziologicheskoy khimii Akademii nauk SSSR
(Laboratory for Physiological Chemistry of the Academy of Sciences, USSR)

PRESENTED: December 23, 1958, by A. I. Oparin, Academician

SUBMITTED: December 23, 1958

Card 3/3

SOV/20-126-5-58/69

17(3)
AUTHORS: Bobrova, L. N., Stepanenko, B. N.

TITLE: On a Guanine Derivative of Yeast Origin Stimulating the Work of the Myocardium (O guaninovom proizvodnom drozhzhevogo proiskhozheniya, stimuliruyushchem rabotu serdechnoy myshtsy)

PERIODICAL: Doklady Akademii nauk SSSR, 1959, Vol 126, Nr 5, pp 1118 - 1120 (USSR)

ABSTRACT: The authors reported in previous papers (Refs 1,2) that they isolated a highly active stimulator of heart activity ZSC (Zymostimulator cordis) from a yeast-fermentation mixture and the fructose-diphosphate preparation (FDPH). By its nature, it is related, or even identical, to the uridine-diphosphate. It was interesting - besides the further investigation of the ZSC - to look for other possible admixtures which are also present in very small quantities but exert a strong biological effect. Recently it has been possible to isolate, from the FDPH-preparation, another substance stimulating the heart activity in a concentration of 1 : 100000; it is a guanine derivative, apparently a guanosine polyphosphate. The further text is divided as

Card 1/3

On a Guanine Derivative of Yeast Origin Stimulating
the Work of the Myocardium

SOV/20-126-5-58/69

follows: The method of isolation consists in the adsorption of the admixtures present in the FDPH in coal, etc (Ref 1). After a threefold chromatography, the chromatographically homogeneous guanine derivative was used for investigating the chemical nature and the biological effect. Detection of guanine. The presence of the guanine derivative was proved by a blue fluorescence in the ultraviolet light after the treatment of the chromatogram with HCl vapors. The absorption curve showed minima and maxima which are characteristic of guanine compounds (Refs 3-5). Figure 1 shows that also the optical density at different wave-lengths speaks for the presence of a guanine derivative. The determination of pentose was carried out with orcin according to Massart (Ref 7) before and after bromination. It has been ascertained that a pentose bound to a purine basis is present. Determination of phosphorus. The ratio between the acid-labile and the total phosphorus was 1 : 2.6. The above results lead to the conclusion that the compound, with respect to its effect on the heart, is a substance which contains residues of guanine, pentose and phos-

Card 2/3

On a Guanine Derivative of Yeast Origin Stimulating
the Work of the Myocardium

SOV/20-126-5-58/69

phoric acid. There are polyphosphate (pyrophosphate) residues present. From the above paper, it can be concluded that the active guanidine derivative apparently is a compound of the type of nucleoside polyphosphates, perhaps a guanosine-diphosphate. The effect of the guanidine derivative on the frog-heart isolated according to Straub was tested as in reference 1. Solutions of the guanidine derivative in question were stimulating in a dilution of 1:100000 (Fig 2). It can be imaged that substances of this type will constitute representatives of a new group of heart stimulators. There are 2 figures, and 7 references, 3 of which are Soviet.

ASSOCIATION: Laboratoriya fiziologicheskoy khimii Akademii nauk SSSR (Laboratory of Physiological Chemistry of the Academy of Sciences, USSR)

PRESENTED: March 17, 1959, by A. I. Oparin, Academician

SUBMITTED: March 16, 1959

Card 3/3

PARNAS, Yakov Oskarovich, akademik [deceased]; DZBANOVSKAYA, A.Ye.
[translator]; ROZENGARD, V.I. [translator]; TOLKACHEVSKAYA,
N.P. [translator]; STEPANENKO, B.N., otv.red.; BRAUNSHTEYN,
A.Ye., red.; KOTEL'NIKOVA, A.V., red.; SEVERIN, S.Ye., red.;
ENGEL'GARDT, V.A., red.; KOLPAKOVA, Ye.A., red.izd-va;
POLYNOVA, T.P., tekhn.red.

[Collected works] Izbrannye trudy. Moskva, Izd-vo Akad.nauk
SSSR, 1960. 491 p. (MIRA 13:7)
(NITROGEN--ANALYSIS) (NAPHTHOQUINONE) (BIOCHEMISTRY)

STEPANENKO, B.N.

Some results achieved and outlook for future study of carbohydrates. Izv. AN SSSR. Ser. biol. no. 2:294-312 ~~Mar~~-Apr '60.

(MIRA 13:6)

1. Institute of Biochemistry, Academy of Sciences of the U.S.S.R.,
Moscow.

(CARBOHYDRATES)

KUZNETSOV, A.A.; STEPANENKO, B.N.

Fate of fructose-1,6-diphosphate and fructose-6-phosphate introduced
into the animal organism. Biokhimiia 25 no.4:705-715 J1-Ag '60.
(MIRA 13:11)

1. Institute of Biochemistry, Academy of Sciences of the U.S.S.R.,
Moscow.

(FRUCTOSE PHOSPHATES)

(PHOSPHORUS METABOLISM)

STEFANOV, B.N., STANKOVA, YE.M., SLOZHENIKOVA, L.V., SOLOVINA, T.T.,

LAKOVA, E.A., BUDAKOVA, M.K., (USSR)

"The Reserve Heteropolysaccharides in Plants."

Report presented at the 5th Int'l. Biochemistry Congress, Moscow,
10-16 Aug 1961.

STEPANENKO, Boris Nikolayevich, prof.; KUVSHINSKIY, M.N., red.;
KUZ'MINA, N.S., tekhn. red.

[Course in organic chemistry] Kurs organicheskoi khimii.
2. izd. Moskva, Medgiz, 1961. 595 p. (MIRA 15:2)
(CHEMISTRY, ORGANIC)

KNUNYANTS, I.L., glav. red.; BAKHAROVSKIY, G.Ya., zam. glav. red.;
BUSEV, A.I., red.; VARSHAVSKIY, Ya.M., red.; GEL'PERIN,
N.I., red.; DOLIN, P.I., red.; KIREYEV, V.A., red.; MEYERSON,
G.A., red.; MURIN, A.N., red.; POGODIN, S.A., red.; REBINDER,
P.A., red.; SLONIMSKIY, G.S., red.; STEPANENKO, B.N., red.;
EPSHTEYN, D.A., red.; VASKEVICH, D.N., nauchnyy red.; GALLE,
R.R., nauchnyy red.; GARKOVENKO, R.V., nauchnyy red.; GODIN,
Z.I., nauchnyy red.; MOSTOVENKO, N.P., nauchnyy red.;
LEBEDEVA, V.A., mladshiy red.; TRUKHANOVA, M.Ye., mladshiy
red.; FILIPPOVA, K.V., mladshiy red.; ZHAROVA, Ye.I., red.;
KULIDZHANOVA, I.D., tekhn. red.

[Concise chemical encyclopedia] Kratkaia khimicheskaiia entsiklo-
pediia. Red. koll.: I.L.Knuniants i dr. Moskva, Gos. nauchn.
izd-vo "Sovetskaia entsiklopediia." Vol.1. A - E. 1961.
1262 columns. (MIRA 15:2)

(Chemistry--Dictionaries)

STEPANENKO, B.N.; ROZENFEL'D, Ye.L.; PAVLINOVA, O.A.; LINEVICH, L.I.

First International Colloquium on Carbohydrate Biochemistry in
Gif-sur-Yvette, France. Biokhimiia 26 no.3:567-568 My-Je '61.
(MIRA 14:6)

(CARBOHYDRATES)

(BIOCHEMISTRY)

STEPANENKO, B.N.; BAKSOVA, R.A.

Production of crystalline d-mannose from a new raw material --
the polysaccharide eremuran. Biokhimiia 26 no.5:855-858 S-0 '61.
(MIRA 14:12)

1. Institute of Biochemistry, Academy of Sciences of the U.S.S.R.
and the 1st Medical Institute, Moscow.
(EREMURAN) (MANNHOSE)

STEPANENKO, B.N.; SLOZHENIKINA, L.V.

Study of intermediate products in the hydrolysis of eremiran.
Dokl.AN SSSR 138 no.6:1460-1463 Je '61. (MIRA 14:6)

1. Institut biokhimii im. A.N.Bakha AN SSSR. Predstavleno akademikom
A.I.Oparinyam.
(EREMURAN) (HYDROLYSIS)

STEPANENKO, B.H.; SERDYUK, O.G.

Kinetics of the acid hydrolysis of certain phenol and
chlorophenol glycosides. Dokl. AN SSSR 139 no.5:1132-1135
Ag '61. (MIRA 14:8)

1. Institut biokhimii im. A.N. Bakha AN SSSR i Kafedra
organicheskoy khimii Pervogo Moskovskogo meditsinskogo
instituta im. I.M. Sechenova. Predstavleno akademikom
A.I. Oparinyam.

(Phenols) (Glycosides) (Hydrolysis)

STEPANENKO, B.N., otv. red.; SEVERIN, S.Ye., red.; DEREVITSKAYA, V.A., red.; ROZENFEL'D, Ye.L., red.; KUZNETSOV, A.A., red.; PARNES, Ya.A., red.izd-va; MAKAGONOVA, I.N., tekhn. red.

[Carbohydrates and carbohydrate metabolism] Uglevody i uglevodnyi obmen; materialy. Moskva, Izd-vo Akad. nauk SSSR, 1962, 335 p. (MIRA 16:1)

1. Vsesoyuznaya konferentsiya po probleme "Khimiya i obmen uglevodov." 2d, Moscow, 1961. 2. Institut biokhimi' im. A.N. Bakha Akademii nauk SSSR (for Stepanenko). 3. Institut biologicheskoy i meditsinskoy khimii Akademii meditsinskikh nauk SSSR (for Rozenfel'd).

(CARBOHYDRATE METABOLISM)

STEPANENKO, B.N.

New area of stereochemistry of sugars, the study of their
conformations. Usp.khim. 31 no.12:1437-1452 D '62. (MIRA 16:2)

1. Institut biokhimi i imeni A.N.Bakha AN SSSR.
(Sugars) (Stereochemistry)

ZELENKOVA, V.V.; STEPANENKO, B.N.

Synthesis of certain aryl-N-glycosides. Dokl. AN SSSR 144
no.2:349-351 My '62. (MIRA 15:5)

1. Institut biokhimi im. A.N.Bakha AN SSSR i Pervyy moskovskiy
meditsinskiy institut im. I.M.Sechenova. Predstavleno akademikom
A.I.Oparinym.

(Glycosides)

BOBROVA, L. N. (Moskva); STEPANENKO, B. N. (Moskva)

Methods of separating and investigating nucleotides. Usp. biol.
khim. 4:134-156 '62. (MIRA 15:7)

(NUCLEOTIDES)

STEPANENKO, Boris Nikolaevich; KUVSHINSKIY, M.N., red.; MIROMOVA,
A.M., tekhn. red.

[Organic chemistry] Organicheskaya khimiya. Izd.3., ispr.
i dop. Moskva, Medgiz, 1963. 411 p. (MIRA 16:5)
(Chemistry, Organic)

. STEPANENKO, B.N.

Modern concepts of the structure of starch polysaccharides. Usp.
biol.khim. 5:171-181 '63. (MIRA 17:3)

STEPANENKO, B.N.; IGNATYUK-MAYSTRENKO, V.A.; CHENTSOVA, M.G.

Hydrolysis kinetics of some N-glycosides. Dokl. AN SSSR 154
no. 3:650-653 Ja '64. (MIRA 17:5)

1. Institut biokhimii im. A.N.Bakha AN SSSR i Pervyy Moskovskiy
meditsinskiy institut im. I.M.Sechenova. Predstavleno akademikom
A.I.Oparinyam.

KUZNETSOV, A.A.; STEPANENKO, B.N.

Acid phosphatase from the roots of some Eremurus species. Dokl.
AN SSSR 155 no. 3:694-697 Mr '64. (MIRA 17:5)

1. Institut biokhimii im. A.N.Bakha AN SSSR. Predstavleno
akademikom A.I.Oparinym.

STEPANENKO, B.N.

A new domain of carbon hydrate stereochemistry; a study of their conformation. Analele chimie 18 no.3:123-142 J1-S '63.

STEPANENKO, B.N.; SHCHERBUKHINA, N.K.

Chemical nature of so-called salep mannan. Dokl. AN SSSR 151
no.4:967-970 Ag '63. (MIRA 16:8)

1. Institut biokhimi im. A.N.Bakha AN SSSR. Predstavleno
akademikom A.I.Oparinym.

(Mannans)

SLOZHENIKINA, L.V.; SHCHERBUKHIN, V.D.; STEPANENKO, B.N.

Studying eremuran and mannan from salep by infrared spectroscopy. Dokl. AN SSSR 153 no.4:960-963 D '63. (MIRA 17:1)

1. Institut biokhimii im. A.N. Bakha AN SSSR. Predstavleno akademikom A.I. Oparinyam.

STEPANENKO, B.N.; SERDYUK, O.G.

Kinetics of alkaline hydrolysis of some phenyl and chloro-phenyl glycosides. Dokl. AN SSSR 154 no.4:877-880 F '64.
(MIRA 17:3)

1. Institut biokhimii im. A.N. Bakha AN SSSR i Pervyy Moskovskiy meditsinskiy institut im. I.M. Sechenova. Predstavleno akademikom A.I. Oparinym.

AFANAS'YEVA, Ye.M.; SHCHERBUKHTNA, N.K.; SHCHERBUKHIN, V.D.; STEPANENKO, B.N.

Polysaccharides in the roots of a desert candle. Dokl. AN SSSR
157 no.6:1470-1473 Ag '64. (MIRA 17:9)

1. Institut biokhimii im. A.N. Bakha AN SSSR. Predstavleno
akademikom A.I. Oparinyam.

STEPANENKO, B.N. (Moskva)

Some advances in the biochemistry of carbohydrates. Usp. sovr.
biol. 59 no.1:77-100 Ja-F '65. (MIRA 18:3)

STEPANENKO, B.N.

Sixth International Biochemical Congress in the United States. Izv.
AN SSSR. Ser. biol. no.4:603-613 J1-Ag '65. (MIRA 18:7)

SHCHERBUKHIN, V.D.; STEPANENKO, B.N.; SERDYUK, O.G.

Infrared spectra of some phenyl - and p-chlorophenyl- β -D-
glycosides and their acetates. Zhur. ob. khim. 35 no. 10:
1822-1851 0 1965. (MIRA 18:10)

STEPANENKO, B.N., otv. red.; KOCHETKOV, N.K., red.; KUDRYASHOV,
L.I., red.; KUZNETSOV, A.A., red.; ROZENFEL'D, Ye.L.,
red.; VASIL'YEVA, L.N., red.

[Chemistry and metabolism of carbohydrates; materials]
Khimiia i obmen uglevodov; materialy. Moskva, Nauka,
1965. 351 p. (MIRA 19:1)

1. Vsesoyuznaya konferentsiya po probleme "Khimiya i ob-
men uglevodov." 3d, 1963. 2. Institut khimii prirodnykh
soyedineniy AN SSSR (for Kochetkov). 3. Institut biokhi-
mii im. A.N.Bakha AN SSSR (for Stepanenko). 4. Institut
biologicheskoy i meditsinskoy khimii AMN SSSR (for
Rozenfel'd).

STEPANENKO, B.N.; SHCHERBUKHINA, N.K.

Study of so-called "salep-mannan". Biokhimiia 29 no. 1:
41-46 Ja-F '64. (MIRA 18:12)

1. Institut biokhimii imeni A.N. Bakha AN SSSR, Moskva.
Submitted March 2, 1963.

AFANAS'YEVA, Ye.M.; SHCHERBUKHIN, N.K.; SHERBUKHIN, V.D.; STEPANENKO, B.N.

Polysaccharides in the roots of various Eremurus species
during different periods of vegetation. Prikl. biokhim. i
mikrobiol. 1 no.2:198-205 Mr-Apr '65.

(MIRA 18:11)

1. Institut biokhimi imeni A.N.Bakha AN SSSR, Moskva.

ACC NR: AP6031650

SOURCE CODE: UR/0020/66/170/001/0121/0124

AUTHOR: Stepanenko, B. N.; Greshnykh, R. D.

ORG: Biochemistry Institute im. A. N. Bakh, Academy of Sciences, SSSR (Institut biokhimi Akademii nauk SSSR); First Moscow Medical Institute im. I. M. Sechenov (Pervyi Moskovskiy meditsinskiy institut)

TITLE: Syntheses of certain N-alkylglycosylamines

SOURCE: AN SSSR. Doklady, v. 170, no. 1, 1966, 121-124

TOPIC TAGS: amine, glycoside, organic synthetic process

ABSTRACT: The purpose of the work was to prepare and characterize the following alkylglycosylamines: methyl-D-glucosylamine (I), methyl-D-galactosylamine (II), methyl-D-arabinosylamine (III), ethyl-D-glucosylamine (IV), ethyl-D-galactosylamine (V), ethyl-D-xylosylamine (VI), butyl-D-glucosylamine (VII), butyl-D-galactosylamine (VIII) and butyl-D-xylosylamine (IX). The method of synthesis was that of W. Sorokin (Ber., 20, 783, 1887) and in the case of ethylglycosylamines, that of G. E. Votocek and F. Valentin (Coll. Czechoslov. Chem. Commun., 6, 77, 1934). The yields, melting points and specific rotations of the compounds obtained are shown in Table 1. IR spectra showed that the compounds do not contain C=N bonds, i. e., are not Schiff bases. The change in optical activity during hydrolysis indicates that the compounds are β -glycopyranosides, with the exception of N-methyl-D-arabinosylamine, which is probably an

Card 1/2

UDC: 547.91

ACC NR: AP6031650

α -glycoside. The paper was presented by Academician Oparin, A. I., 24 Dec 65. Orig. art. has: 1 table.

Table 1

	Yield, %	M.P., °C	$[\alpha]_D$
I	64	76-78	-8.5°; -3.8°; +13.6°
II	70	110-112	+34°; +26.6°; +34°
III	72.6	108	-40.1°; -45.7°; -47.6°
IV	83.3	77-78	-6.17°; +12.6°
V	74	100-110	+26.7°; +41.6°
VI	76.9	60-70	-25.4°; -8.5°
VII	82.7	87-88	-16°; -11.3°; +6.6°
VIII	68.9	90-101	+16.6°; +26.6°; +28.3°
IX	87.9	81-83	-29.3°; -19.9°; -16.7°

*Specific rotation determined in water

SUB CODE: 07/ SUBM DATE: 14Dec65/ ORIG REF: 002/ OTH REF: 008

Card 2/2

STEPANENKO, B. N.; IGNATYUK-MAYSTRENKO, V.A.; CHENTSOVA, M. G.

"Studies on the Hydrolysis of Glycosylamines."

report ~~to be~~ submitted for the 6th Intl Biochemistry Cong, New York City, 26 Jul-
1 Aug 64.

STEPANENKO, D.P.

Edibility of plants in Alpine sheep pastures of the Kirghiz
Range. Uch.zap.Biol.-pochv.fak.Kir.un. no.3:26-28 '52. (MLRA 10:5)
(Kirghiz range--Pastures and meadows)
(Sheep--Feeding and feeding stuffs)

STEPANENKO, D.P.

Yields and productivity of the mint-varied grass pastures of
the Kirghiz Range. Uch.zap.Biol.-pochv.fak.Kir.un. no.3:39-53
'52. (MLHA 10:5)
(Kirghiz range--Pastures and meadows)
(Sheep--Feeding and feeding stuffs)

USSR/Cultivated Plants - Fruits. Berries.

M-6

Abs Jour : Ref Zhur - Biol., No 7, 1958, 29996

Author : Stepanenko, D.P.

Inst : -

Title : New Fruit Varieties in Kirgizia.

Orig Pub : Uch. zap. Biol.-pochv. fak. Kirg. un-t, 1955, vyp. 5,
111-119.

Abstract : Description is given of the cultivation method for new varieties of Rayka Tyan'-Shanskaya and for the hybrid plum from the Japanese plum (*Prunus salicina* Lindl.) x *P. divaricata*, called the Kyzyl Pioner.

Card 1/1

- 4 -

CATEGORY : USSR
 : Cereals, Grains, Leguminous Cereals,
 : Tropical Cereals.
 REF. JOUR : *Tr. Khark. gos. un-t.* No. 5, 1958, pp. 202-24
 AUTHOR : Stepanenko, D.F.
 INST. : Biology Faculty, Kirgiz University
 TITLE : Chul' wheat and its controlled cultivation.

ORIG. PUB.: Uch. zap. Biol. fak. Kirg. un-t, 1957,
 vyp. 8, 3-12

ABSTRACT : After four years of cultivation in the winter sowing at the Botanical Garden of Kirgiz University, the Chul' population was classified among the *Erythrosperrum* and *Grecum* varieties. In winter planting the *Grecum* began shooting one week sooner than *Erythrosperrum* and ripened 2-3 days earlier. In summer planting (March, June) *Grecum* developed normally as a summer crop, and yielded a harvest; *Erythrosperrum* when planted in March yielded

CARD: 1/3

STEPANENKO, D.P., dotsent

Characteristics of hybrids produced by crossbreeding Polish and
branched wheats. Uzh. zap. Biol.-pochv. fak. Kir. un. no.7:3-17
'58. (MIRA 15:10)

(Kirghizistan--Wheat breeding)

STEPANENKO, E.M., mladshiy nauchnyy sotrudnik

Colorimetric determination of aluminum and its compounds
in the air. Gig. i san. 26 no.7:66-69 J1 '61. (MIRA 15:6)

1. Iz Leningradskogo nauchno-issledovatel'skogo instituta
gigiyeny truda i professional'nykh zabolevaniy. (COLORIMETRY)
(ALUMINUM) (AIR--ANALYSIS)

KOMAROVA, Ye.N.; STEPANENKO, E.M.

Toxicological characteristics of the products of thermal decomposition
of "SN-28" and SN-28P" materials. Plast.massy no.12:39-40 '63.
(MIRA 17:2)

PEREGUD, Ye.A.; STEPANENKO, E.S.; BOYKINA, B.S.

Determination of very small amounts of acids in air. Zhur.
anal.khim. 17 no.6:770-771 S '62. (MIRA 16:1)

1. Leningradskiy nauchno-issledovatel'skiy institut gigiyeny
truda i professional'nykh zabolevaniy.
(Acids) (Air-Analysis)

STEPANENKO, F.N., inzh. (g. Fastov).

Technological methods for efficient use of marshalling systems.
Zhel. dor. transp. 39 no.12:71-72 D '57. (MIRA 11:1)
(Railroads--Hump yards)

ROGOVIN, D.A., inzh.; STEPANENKO, F.V., inzh.

Using gamma rays for checking the quality of welded joints.
Mashinostroenie no. 2:76-77 Mr-Ap '64. (MIRA 17:5)

ROGOVIN, D.A.; STEPANENKO, F.V.

Separation of dust from grit and shot. Lit. proizv. no.3:39-40
№ 164. (MIRA 18:9)

CHEREPANOV, V.; STEPANENKO, G.; KARPOV, S.

Experience in copper casting. Izobr.1 rats. no.8:39 Ag '58.
(MIRA 11:9)

1. Sotrudniki Karagandskogo nauchno-issledovatel'skogo ugol'nogo
instituta.

(Suggestion systems)

STEPANENKO, G. [Stepanenko, H.], inzh.; LESHCHINER, B., inzh.

Increasing the refractoriness of bitumen. Bud. mat. i konstr.
4 no.2:45-46 Mr-Ap '62. (MIRA 15:9)
(Bitumen)

AKRAMOVA, A.S.; GLUSHENKOVA, A.I.; MARKMAN, A.L.; STEPANENKO, G.A.; UMAROV, A.U.;
CHERNENKO, T.V.

Oilseeds of some species of leguminous plants. Uzb. khim. zhur. 8 no.6:
31-36 '64. (MIRA 18:4)

1. Institut khimii rastitel'nykh veshchestv AN UzSSR.

YAKOVLEV, V.G.; STEPANENKO, G.D.

Role of formed elements of the blood in protein metabolism.
Izv. AN Kir. SSR. biol. nauk 3 no.2:25-31 '61. (Mir 14:12)
(BLOOD CELLS) (PROTEIN METABOLISM)

LARTSEV, German Grigor'yevich; STEPANENKO, Gennadiy Georgiyevich;
GORKUNOV, V.I., otv.red.; IVANOV, S.I., red.izd-va; CHASOVIKOVA,
Z.I., tekhn.red.

[Ways to reduce the cost of temporary timbering in mines of the
"Karagandashakhtastroi" Combine] Puti snizhenia stoimosti
vremennogo krepnenia na shakhtakh kombinata "Karagandashakhto-
stroi." Alma-Ata, TSentr.in-t nauchno-tekhn.informatsii, 1958.
11 p. (MIRA 13:8)

(Karaganda Basin--Mine timbering--Costs)

CHEREPANOV, V.V., gornyy inzh.; STEPANENKO, G.G., gornyy inzh.

Performance of a cutter-loader brigade in Karaganda mine No.37.
Ugol' 33 no.11:35-36 N '58. (MIRA 11:11)
(Karaganda Basin--Coal mining machinery)

STEPANENKO, G.G., inzh.

Efficiency promoters improve working conditions. Bezop.truda v prom. 3
no.1:33 Ja '59. (MIRA 12:3)
(Mining engineering--Safety measures)

6
STEPANENKO, G., inzh.

^
Efficiency promoters improve labor safety. Bezop.truda v
prom. 4 no.3:19-20 '60. (MIRA 13:6)
(Coal mines and mining--Safety measures)

L 09066-67 EWP(e)/EWT(m)/T/EWP(t)/ETI/EWP(k) IJP(o) JD/WW/JG/DJ/WH
ACC NR: AP6030609 (A, N) SOURCE CODE: UR/0413/66/000/016/0095/0099

3

INVENTOR: Rabinovich, L. S.; Sharapov, A. M.; Rubashkin, L. I.; Radomyasl'skiy, I. D.; Klimenko, V. N.; Konchakovskaya, L. D.; Stepanenko, G. M.; Kanovalov, V. M.

17

ORG: none

TITLE: Cermet materials. Class 40, No. 185069 [announced by the Institute of Material Study, AN UkrSSR (Institut problem materialovedeniya AN UkrSSR)]

SOURCE: Izobreteniya, promyshlennyye obrabotey, tovarnyye snaki, no. 16, 1966, 95

TOPIC TAGS: iron containing material, cast iron, containing material, steel, containing material *metal ceramic material, cermet*

ABSTRACT: This Author Certificate introduces a sintered material containing (for better wear resistance) 60-70% iron powder, 20-30% cast iron powder, and 10-12% steel powder, such as Kh-30 steel powder. This material is used for extending the service life of stators and disks of rotary double-action pumps. [ND]

SUB CODE: 11/ SUBM DATE: 27Jul64/ ATD PRESS: 5077

Cord 1/1 net

UDC: 669.018.25: 1621.762.2

S/121/61/000/006/002/012
D040/D112

AUTHORS: Zaychenko, I.Z., Konovalov, V.M., Myshlevskiy, L.M., and
Stepanenko, G.M.

TITLE: New long-life vane pumps

PERIODICAL: Stanki i instrument, no. 6, 1961, 6-10

TEXT: New vane pumps for the hydraulic drives of machine tools have been developed by ENIMS in cooperation with the Yeletskiy zavod stanochnoy gidroapparatury (Yelets Machine Tool Hydraulic Equipment Plant). The new "Г" (G) series pumps will replace the old "Л" (L) pumps, i.e. Л1Ф (L1F), Л3Ф (L3F), and Л5К (L5K), that have high hydraulic losses. The article gives detailed design description of the Г12-2 (G12-2) and Г12-4 (G12-4) and dimension charts of other pumps of the series. The major share of leakage in the old design is through the passage q₃ (Fig. 2), i.e. from the groove under vanes into the intake space through the butt-end gap between the rotor and the discs. This explains why wear on the butt faces of the distributing discs raises oil loss so much. In the new design (Fig. 3) the distribution discs (8) and (7) are made of case-hardened 20X (20Kh) steel with Rc 56-52 hardness, and the disc (8) is floating, i.e. it is pressed to the stator (3) Card 1/6

New long-life vane pumps

S/121/61/000/006/002/012
D040/D112

by springs (9) at the start of operation, and by oil pressure during operation. In Fig. 3, 1 is the pump casing, 2 the cover and 5 the rotor. This makes the assembling simpler and eliminates the danger of jamming. The output and intake ducts are open, the rotor has no trunnion. The G12-4 has eight vanes (4) and the G12-2 twelve. The rubber sealings (10) and (6) are standard. The stator profile and dimensions were chosen in accordance with recommendations by I.Z. Zaychenko (Ref. 2: "Stanki i instrument", no. 8, 1956). When coupled, the G12-2 and G12-4 pumps (Fig. 4) have one intake and two separate outlets. Calculation of the pressure on the floating disc is given. The G12-2 pumps of 5-50 liter/min capacity can work at up to 1440 shaft rpm. The life-time of the new pumps is 4-5 times longer than that of the old they are replacing. Pressure on the floating distributing disc (pressing it to the stator) must have a certain value (α) that is obtained when the floating disc surface area under the effect of intake oil pressure (F_{in}) exceeds F_o 1.19 times, i.e. the following condition must be satisfied:

$$\alpha = \frac{F_{in}}{F_o} \gg 1.19. \quad (5)$$

Card 2/6

S/121/61/000/005/002/012
D040/D112

New long-life vane pumps

The maximum work pressure of the G12-4 type pumps is 50 kgf/cm , and of the G12-2 - 64 kgf/cm . The G12-4 is smaller than the G12-2. Both are designed for application in new standard-unit power heads developed by the SKB-1 for Stankozavod im. S. Ordzhonikidze (Machine Tool Plant im. S. Ordzhonikidze) as well as other hydraulic drives where minimum size and weight are important. There are 12 figures, 3 tables and 2 Soviet references.

✓

Card 3/6

S/121/61/000/006/002/012
D040/D112

New long-life vane pumps

Fig. 2: The paths of leakage in the LLF vane pump. (q_3 the path of highest leakage)

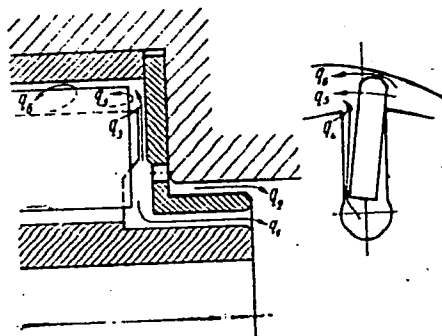

Card 4/6

New long-life vane pumps

S/121/61/000/006/002/012
D040/D112

Fig. 3: The G12-2 and G12-4 single pumps (1) - Intake; (2) - Pressure.

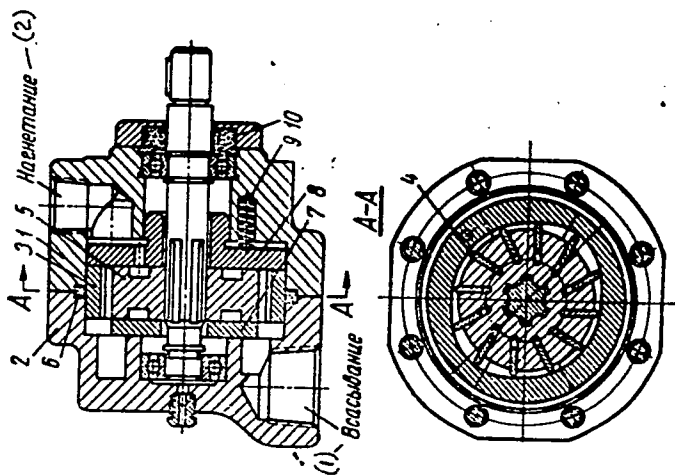

Card 5/6

New long-life vane pumps

S/121/61/000/006/002/012
D040/D112

Fig. 4: Dual G12-2 and G12-4 design. (1) - Intake; (2) - pressure;
(3) - drain.

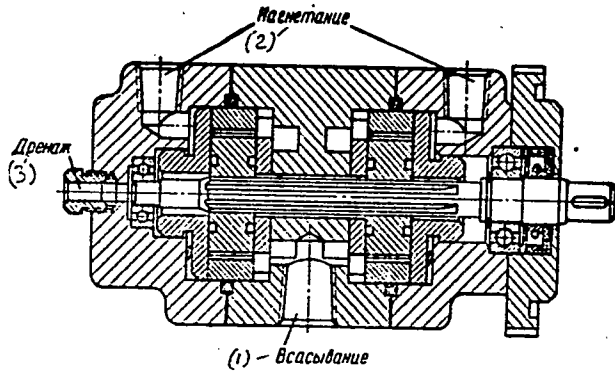

Card 6/6

STEPANENKO, G.N., inzhener (st. Fastov II).

Improved brake shoe release. Zhel.dor.transp. 37 no.1:80 Ja '56.
(MLRA 9:3)

(Railroads--Brakes)

STEPANENKO, G.P. (Kiyev)

Lasting strength and creep of clays under uniaxial compression.

Prikl. mekh. 1 no.5:105-110 '65.

(MIRA 18:7)

1. Kiyevskiy inzhenerno-stroitel'nyy institut.

L 42172-66 EWP(j)/EWT(m)/T RM/DJ

ACC NR: AR6014533

(N)

SOURCE CODE: UR/0081/65/000/019/P022/P022

AUTHORS: Nemkov, A. V.; Kazanskiy, V. L.; Stepanenko, G. S.; Badyshtova, K. M. 41TITLE: Preparation of a new viscosity additive B

SOURCE: Ref. zh. Khimiya, Abs. 19F152

REF SOURCE: Tr. Kybyshovsk. n.-i. in-t neft. prom-sti, vyp. 25, 1964, 101-017

TOPIC TAGS: viscosity additive, lubricating oil, catalytic polymerization, industrial condition

ABSTRACT: Experiments (performed first under laboratory conditions and then in a factory--2 experimental runs) led to the development of an industrial process for polymerization of butane¹-butylene¹gaseous fraction from thermal cracking. The purpose of the work was to develop a viscosity additive of molecular weight ~ 3000 to lubricating oils. The optimal conditions for the polymerization of this fraction are: temperature -30C; pressure 0--2 atm; reaction time 7--9 hours; catalyst $AlCl_3$.

Approximate characteristics of the process (based on the sum of unsaturated C_4) are: yield of the final product 70--80%, consumption of the catalyst 0.5--1.0%. A. N.

[Translation of abstract]

SUB CODE: 11/

Card 1/1

STEPANENKO, I., general-mayor aviatsii, dvazhdy Geroy Sovetskogo Soyuza

On courses of head-on flights. Av. i kosm. 47 no.11:85-86 II '64.
(MIRA 17:11)

STEPANENKO, I., dvazhdy Geroy Sovetskogo Soyuz, general-mayor aviatsii

The flight commander, the first instructor of pilots. Komm. Vooruzh.
Sil 46 no.9:36-38 My '65. (MIRA 18:7)

MANSHILIN, V.V.; AGAFONOV, A.V.; MANAKOV, N.Kh.; VASILENKO, V.P.;
MASLOV, I.Ya.; KNYAZEV, V.S.; STEPANENKO, I.A.; Primali
uchastiye: VAYL', Yu.K.; NEMETS, L.L.; BELOUSOVA, I.V.;
STOLYARENKO, Ye.G.; YEMEL'YANOV, A.A.; RYABOV, V.M.;
BEREZOVSKIY, V.D.; ZEFIROVA, Ye.G.; CHELOGUZOVA, Ye.F.;
SOLOTSINSKIY, S.Ye.; BOL'SHAKOVA, K.A.; KHRAMOV, A.Ye.

Catalytic cracking of raw heavy distillates on a microspheric
catalyst of Troshkovskiy clay. Khim. i tekh. topl. i masel. 8
no.3:1-6 Mr '63. (MIRA 16:4)

1. Vsesoyuznyy nauchno-issledovatel'skiy institut po pererabotke
nefti i gazov i polucheniyu iskusstvennogo zhidkogo topliva.
(Cracking process) (Catalysts)

MANSHILIN, V.V.; MANAKOV, N.Kh.; AGAFONOV, A.V.; VASILENKO, V.P.;
MASLOV, I.Ya.; KNYAZEV, V.S.; Primali uchastiye: BELOUSOVA, I.V.;
BEREZOVSKIY, V.D.; BOL'SHAKOVA, K.A.; YEMEL'YANOV, A.A.;
ZEFIROVA, Ye.G.; NEMETS, L.L.; OKINSHEVICH, N.A.; RYABOV, V.M.;
STEPANENKO, I.A.; STOLYARENKO, Ye.G.; SOLOTSINSKIY, S.Ye.;
KHRAMOV, A.Ye.; CHELOGUZOVA, Ye.F.

Engineering development of a new system of catalytic cracking
in a fluidized bed. Khim.i tekh.topl.i masel 7 no.6:41-50
Je '62. (MIRA 15:7)

1. Vsesoyuznyy nauchno-issledovatel'skiy institut po pererabotke
nefti i gazov i polucheniyu iskusstvennogo zhidkogo topliva.
(Cracking process)
(Fluidization)

TITKOV, V.I.; ALEKSANDROV, A.M.; ~~STEPANENKO, I.A.~~

Study of hermetic seals in floating roof tanks. Trudy VNII NP no.5:
86-99 '56. (MLRA 9:8)
(Tanks) (Petroleum--Storage)

BORISOV, M.D.; ZYKOV, V.G.; STEPANENKO, I.A.; TERNOPOL, A.M.;
PADALKA, V.G.; BRZHECHKO, L.V.

[Plasma production by the radial compression method and
measurement of certain plasma parameters] Poluchenie plaz-
my metodom radial'nogo szhatiia i izmerenie ee nekotorykh
parametrov. Khar'kov, Fiziko-tekhn. in-t AN USSR, 1960.
277-294 p. (MIRA 17:3)

S/781/62/000/000/036/036

AUTHORS: Borisov, M. D. (deceased), Brzhechko L. V., Zykov V. G.,
Padalka V. G., Stepanenko I. A., Ternopol, A. M.

TITLE: Spectroscopic measurements of ion temperature and ion density

SOURCE: Fizika plazmy i problemy upravlyayemogo termoyadernogo sinteza;
doklady I konferentsii po fizike plazmy i probleme upravlyayemykh
termoyadernykh reaktsiy. Fiz.-tekh. inst. AN Ukr.SSR. Kiev, Izd-vo
AN Ukr. SSR, 1962. 170-172

TEXT: Results are described, obtained with a model of the straight-line
portion of racetrack apparatus for the study of discharge stability. The plasma
was produced by the method of Colgate and Wright (ref. 1, Russian translation
cited) in a glass tube 50 cm long and 8 cm in diameter, at a pressure of 10^{-2} mm
Hg. An alternating longitudinal field up to 4000 G was produced by discharging
a 3 microfarad capacitor; the field period was 14 microseconds. The field at
the center of each coil was double the value, so that the mirror ratio was 2:1.
The ion temperature and density were determined by studying the contour of the
Balmer-series H_{α} line. It was estimated that only the Doppler effect and the

Card 1/2

Spectroscopic measurement of ion ...

S/781/62/000/000/036/036

statistical Stark effect contribute to the contour noticeably. Streak photographs have shown that the influence of radial plasma oscillations is small and the random motion of the ions does not affect the ion temperature appreciably. The correction for the apparatus function was determined with the aid of a Fabry-Perot interferometer. The experimentally obtained contour shows that the shape of the central portion is determined by the Doppler effect only, and the statistical Stark effect influences only the skirts (Holtzmark broadening). The ion temperature as determined from the half-width of the Gaussian curve was found to be approximately 4.5 eV, while the ion density ranged between 5×10^{14} and 10^{15} cm^{-3} . Were the hydrogen to be completely ionized, the density would be $3 \times 10^{15} \text{ cm}^{-3}$. There is one figure.

Card 2/2

ACCESSION NR: AT4036069

S/2781/63/000/003/0262/0273

AUTHORS: Zy*kov, V. G.; Stepanenko, I. A.; Tolok, V. T.; Sinel'-nikov, K. D.

TITLE: Investigation of plasma capture in a magnetic trap

SOURCE: Konferentsiya po fizike plazmy* i problemam upravlyayemogo termoyadernogo sinteza. 3d, Kharkov, 1962. Fizika plazmy* i problemy* upravlyayemogo termoyadernogo sinteza (Plasma physics and problems of controlled thermonuclear synthesis); doklady* konferentsii, no. 3. Kiev, Izd-vo AN UkrSSR, 1963, 262-273

TOPIC TAGS: plasmoid, plasma source, plasmoid plasma interaction, magnetic trap, plasma confinement, Coulomb repulsion force, plasma injection

ABSTRACT: The first reports are presented of experiments on the confinement of a plasma in a trap with bucking fields, with simultaneous

Card 1/4

ACCESSION NR: AT4036069

injection of plasma in the opposite direction. The apparatus consists of a cylindrical vacuum chamber 20 cm in diameter made of stainless steel and placed inside the field-producing coils. Each coil is connected to buck the neighboring one, so that three traps with sharp-angle magnetic field geometry are produced, with a 15.6 cm distance between magnetic gaps. Conical plasma guns were used. The plasma was injected into the apparatus pumped out to 6.6×10^{-4} n/m². The central trap was the principal one and the outer ones served for injection of the plasma into the central trap. Double electrostatic probes were used to measure the ion density, the electron temperature, and the time dependence of the density. The plasma propagation in the trap was investigated by using targets of photographic paper, the surface of which burned out after several impacts by the plasma. The apparatus and the probes are described in detail. The interaction of the opposing plasma streams is confirmed by several of the results of the investigations. Estimates also show that Coulomb interaction exists between the plasmoid particles. It is

Card 2/4

ACCESSION NR: AT4036069

pointed out that both the apparatus and the method are preliminary and this affects the accuracy of the final results. Orig. art. has: 12 figures.

ASSOCIATION: None

SUBMITTED: 00

DATE ACQ: 21May64

ENCL: 01

SUB CODE: ME

NR REF SOV: 003

OTHER: 003

Card 3/4

ACCESSION NR: AT4036069

ENCLOSURE: 01

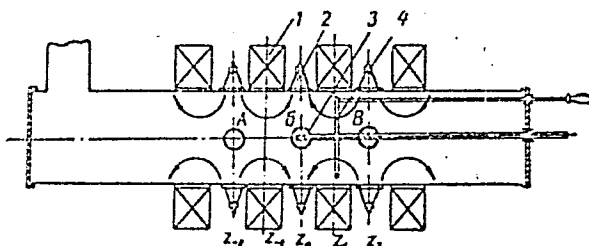

Diagram of setup: 1 - magnetizing coils, 2 - plasma gun, 3 - double electric probe, 4 - diamagnetic probe,

Card 4/4

41565

S/057/62/032/010/003/010
B104/B102

26.2371
AUTHORS:

Zykov, V. G., Il'yenko, B. P., Lats'ko, Ye. M., Stepanenko,
I. A., Ternopol, A. M., Tolok, V. T., and Sinel'nikov, K. D.

TITLE: Investigation into the properties of magnetic surfaces in
systems with a helical magnetic field

PERIODICAL: Zhurnal tekhnicheskoy fiziki, v. 32, no. 10, 1962, 1190-1196

TEXT: The shapes of the magnetic surfaces in systems with stabilizing
helical windings were studied by the method of the preceding electron beam,
developed by F. V. Karmanov and P. A. Cheremnykh at the Institut atomnoy
energii im. I. V. Kurchatova (Institute of Atomic Energy imeni I. V.
Kurchatov) and by injecting plasma clouds into a right cylinder with a
three-turn coil, or by injecting them into the curvilinear section of a
stellarator model. In the experiments with the preceding electron beam a
fluorescent screen was used in the right cylinder (Fig. 1); in the experi-
ments with the plasma clouds special targets were used, superficially
charged by the plasma particles. If no current flows in the helical
windings, the electron beam forms concentric circles on the fluorescent
Card 1/3

S/057/62/032/010/003/010
B104/B102

Investigation into ...

screen. As the amperage in the helical winding increases, the circles degenerate to triangles, whose sides later bend inward. The largest and smallest radii of the separatrices measured as functions of I_{hel}/H_z , and the distortions of the magnetic surfaces caused by deviations of the magnetic axis from the geometric axis, are in agreement with theoretical results. The cross sections of the plasma clouds were studied as functions of I_{hel}/H_z in clouds completely filling the cross section of the tube, and in clouds partially screened by diaphragms. In the former case two types of particles were distinguished, one type remaining trapped in the central part of the cloud bounded by a separatrix, the other escaping from the confinement region. In the second case all plasma particles remained in the confinement region if the radius of the separatrix exceeded that of the clouds, but if it was smaller the same result was obtained as in the first case. The separatrix is a function of the confining induction and of the amperage in the helical windings. This agrees with the theory. The magnetic surfaces in the curvilinear chamber of a stellarator model was studied by the same methods, yielding practically the same results with the electron beam as those obtained with the right cylinder. It is only in the

Card 2/3

S/057/62/032/010/003/010
 B104/B102

Investigation into ...

initial stage of the discharge that the electrons escape to the copper-walls of the vacuum chamber (diameter 80 mm) which was shaped as a semi-toroid (mean radius of curvature 42 cm). It is concluded that at low velocities and small densities the plasma particles move along the lines of the magnetic field. There are 8 figures.

SUBMITTED: November 29, 1961

Fig. 1. Experimental arrangement (right cylinder).

Legend: (1) coils producing the magnetic mirror field; (2) coils producing the main field; (3) mouthpiece for 3-cm waves; (4) conic plasma gun; (5) electric probes; (6) fluorescent screen; (7) helical winding.

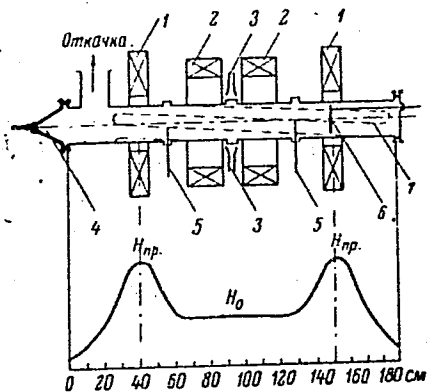

Card 3/3

ACCESSION NR: AT4036070

S/2781/63/000/003/0273/0282

AUTHORS: Zy*kov, V. G.; Stepanenko, I. A.; Tolok, V. T.; Sinel'nikov, K. D.

TITLE: Injection of plasma through an annular gap of a trap with opposing magnetic fields

SOURCE: Konferentsiya po fizike plazmy* i problemam upravlyayemogo termoyadernogo sinteza. 3d, Kharkov, 1962. Fizika plazmy* i problemy* upravlyayemogo termoyadernogo sinteza (Plasma physics and problems of controlled thermonuclear synthesis); doklady* konferentsii, no. 3. Kiev, Izd-vo AN UkrSSR, 1963, 273-282

TOPIC TAGS: plasmoid, plasma source, plasmoid plasma interaction, magnetic trap, plasma confinement, plasma injection

ABSTRACT: With an aim at reducing the particles lost when a plasma is injected into the trap through one of the axial magnetic mirrors,

Card 1/4

ACCESSION NR: AT4036070

the authors investigated the injection of plasma through the annular gap in the magnetic field from sources distributed around the gap periphery. The report describes the first experiments in which injection was investigated both in a stationary gap in the magnetic field, as well as in the gap existing during a certain time ("magnetic valve"). To simplify the initial experiments, the injection gap was produced by a constant field, with the coils connected to buck each other. A 20-cm diameter and 180-cm long cylindrical stainless steel vacuum chamber was used. Eight conical plasma guns were distributed uniformly around the periphery of the chamber in the magnetic gap plane. The synchronization circuit permitted simultaneous switching of all eight guns or a fraction of them. The plasmoids injected by each gun had a density $2 \times 10^{14} \text{ cm}^{-3}$ and a velocity of $3 \times 10^4 \text{ m/sec}$. The working vacuum was $6.6 \times 10^{-4} \text{ n/m}^2$. The maximum magnetic field intensity, equal to $2 \times 10^5 \text{ A/m}$, was located 40 cm away from the magnetic gap. The experiments have shown that a plasma injected into a gap between opposing magnetic fields moves subse-

Card 2/4

ACCESSION NR: AT4036070

quently along the system axis. A strong interaction was observed between the opposing plasma streams, even in the absence of external magnetic fields. The nature of this interaction, and the time of confinement of the plasma in the trap when such an injection method is used, will be investigated in the future. Orig. art. has: 9 figures.

ASSOCIATION: None

SUBMITTED: 00

DATE ACQ: 21May64

ENCL: 01

SUB CODE: ME

NR REF SOV: 002

OTHER: 002

Card 3/4

ACCESSION NR: AT4036070

ENCLOSURE: 01

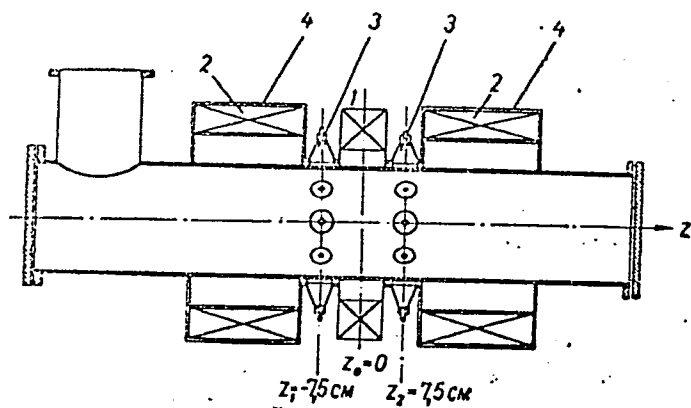

Diagram of set-up: 1 - coil of opposing magnetic field, 2 - coil of main magnetic field, 3 - plasma guns, 4 - protective shield

ard 1/4

ACCESSION NR: AP4042928

S/0057/64/034/008/1417/1423

AUTHOR: Zy*kov, V. G.; Sinitsa, N. G.; Stepanenko, I. A.; Tolok, V. T.; Sinel'nikov, K. D.

TITLE: Investigation of interaction of plasma fluxes in a transverse magnetic field

SOURCE: Zhurnal tekhnicheskoy fiziki, v. 34, no. 8, 1964, 1417-1423

TOPIC TAGS: plasma thermalization, plasma interaction, plasma flux collision

ABSTRACT: This article is a continuation of experimental investigations of the possibility of complete slow-down and thermalization of fast opposed plasma fluxes in order to convert the kinetic energy of their directed motion into thermal energy. The investigation was carried out with apparatus consisting of a plasma source, a plasma guide, a magnetic screen, 8 magnetic coils, a vacuum chamber, a double electric probe, and a collector probe. The chamber, which was 20 cm in diameter, was placed in a longitudinal magnetic field produced by coils driven by a d-c current generator. The field could be

Card 1/2

ACCESSION NR: AP4042928

varied from 0 to 0.5 T. Eight plasma guns were distributed along the inner circumference of the central part of the chamber. The discharge period was 6 μ sec. The plasma consisted of fast and slow components with velocities of 8×10^4 and 3×10^4 m/sec respectively at 4 kv potential in the gun and contained hydrogen, carbon, oxygen, and nitrogen ions. High-speed photography was used for recording. The experiments show that during head-on collisions of the opposed plasma flows in a transverse magnetic field, a strong slow-down to a complete stop of their motion in the initial direction occurs. Contrary to Coulomb interactions, this interaction does not occur in the volume of plasma streams but in their forward fronts and is of a turbulent character. It is important to note that such an interaction should take place even when there is no Coulomb interaction. Orig. art. has: 12 figures and 1 formula.

ASSOCIATION: none

SUBMITTED: 27Nov63

ATD PRESS: 3074

ENCL: 00

SUB CODE: NP, EM

NO REF SOV: 004

OTHER: 004

Card 2/2