

Kvaratskheliya, N. T.

Comparison of methods of soil preparation for mechanical analysis. N. T. Kvaratskheliya. Soobshcheniya Akad. Nauk Gruzii. S.S.R. 18, No. 4, 313-17(1956).—It was shown that the Kachinskii method (pretreatment with 0.05N HCl, washing, and boiling with H₂O) is poorly effective in a no. of soil samples which contained considerable amounts of Fe₂O₃. The best soil dispersion is attained by the use of Trapa reagent and Na oxalate. G. M. Kosolapoff

M-7

2000

CIA-RDP86-00513R000928310009-9"

USSR/Cultivated Plants - Subtropical. Tropical.

Abs Jour : Ref Zhur - Biol., No 7, 1958, 30093

Author : Kvarakhtseliya, N.T.

Inst : The All-Union Scientific Research Institute for Tea and Subtropical Cultures.

Title : The Influence of Fertilizers on the Development of Tea and Citrus Root Systems.

Orig Pub : Soobshch. AN GrusSSR, 17, No 3, 261-264

Abstract : Tests with the tangerine were made on the podzolic soil at the Kelasur Base of the Sukhumskiy affiliate of the All-Union Scientific Research Institute for Tea and Sub-tropical Cultures, and with tea on the red earth at the Chakvinskiy affiliate. Fertilization was applied to the tangerine plantation, planted in 1938, yearly since 1947: 1) FK according to the agriculturally prescribed rate and

KVARATSKHELIYA, N.T.
KVARATSKHELIYA, N.T.

Degree of cultivation observed in subtropical Podzolic soils and
Red earth [with summary in English]. Pochvovedenie no.9:111-116
'57. (MIRA 10:12)

1. Institut pochvovedeniya, agrokhimii i melioratsii AN
Gruzinskoy SSR.
(Georgia--Podsol) (Georgia--Soils, Red)

KVARATSEHELIA, N.T.

Physical characteristics of meadow-bog soils of the Kelkhida
Lowland [with summary in English]. Pochvodadenia no.2:52-58 F
'59. (MIRA 12:3)

1. Institut pochvedeniya, agrokhimii i melioratsii, g. Tbilisi.
(Colchis--Soils)

BYANTSEBINA, N.P.; ANKATOV, G.N.

Effect of some soil properties on the uptake of radioactive strontium by barley. Soch. AN Gruz. SSR 36 no.3:641-646 P 1c4.
(MIRA 18:3)

1. Institut pochvovedeniya, agrokhimii i melioratsii, Tbilisi.
Submitted April 3, 1964.

KVARATSKHELIA, N.T.; GLONTI, G.G.

Migration of strontium-90 in soils in Georgia. Pochvovedenie
no.10:64-71 O '65. (MIRA 18:11)

1. Institut pochvovedeniya, agrokhimii i melioratsii Gruzinskoy
SSR.

XGDANASHVILI, V.A.; AKEMENKO, V.B.; PAPOV, V.A.; KVARATSKHELIYA, B.K.

Properties of the products of chlorinated kerosine. Trudy GPI
[Gruz.] no.5:89-95 '62. (MIRA 27:10)

Use of chlorinated kerosines for the refining of lubricating
greases. Ibid.:97-100

KVARATSKHELIYA, R.K.

Electrosynthesis of hydroxylamine bromide. Soob. AN Gruz. SSR
30 no.4:437-440 Ap '63. (MIRA 17:9)

1. Institut prikladnoy khimii i elektrokhemii AN GruzSSR, Tbilisi.
.. Predstavleno akademikom R.I. Agladze.

AGLADZE, R.I.; KVARATSKHELIYA, R.K.

Electrosynthesis of hydroxylamine sulfate in 20% sulfuric acid.
Khim.prom. no.1:37-40 Ja '62. (MIRA 15:1)
(Hydroxylamine)

S/064/63/000/001/004/007
B101/B186AUTHORS: Agladze, R. I., ^{Co}Kyartskheliya, R. K.

TITLE: Effect of the cathode material and composition of electrolyte on the electrosynthesis of hydroxylamine sulfate

PERIODICAL: Khimicheskaya promyshlennost', no. 1, 1963, 48 - 52

TEXT: The current yield of NH_2OH and NH_3 on various cathodes was determined during the electroreduction of HNO_3 in 20 % H_2SO_4 at 24 a/dm^2 , 18°C, and 60 g/l HNO_3 . The following yield percentage was obtained (first figure % hydroxylamine, second figure % ammonia) for Cu: 0, 70; Pb: 0, 60.5; Sn: 58.6, 27.7; graphite: 32.1, 45.2; Al: 0, 32.9 %; Pt: 0, 6.1; Cr: 0, 41.6; Mo: 0, 26.8; Ta: 0, 24.4; W: 0, 51.8; Fe: 0, 68.1; Co: 24.4, 65.5; Ni: 19.2, 44.1; Cd: 30.5, 79.0; Zn: 51.0, 108.2; Cu amalgamated: 80.1, 3.5; Sn amalgamated: 64.3, 2.2; Pb amalgamated: 70.0, 1.6; Al amalgamated: 70.0, 3.4; Zn amalgamated: 71.4, 0.8, and Hg: 86.0, 0. The high yields obtained for Zn and Cd are due to an additional reduction of HNO_3 .

Card 1/3

Effect of the cathode material ...

S/064/63/000/001/004/007
B101/B186

by the metal. The polarization curves of the Pb and Sn cathodes in 20 % H_2SO_4 showed stages whose height depended on the HNO_3 concentration and which were especially pronounced at 60 g/l of HNO_3 . The cathode starts to dissolve in the inflexion range, whereas in the range following that, the metal is protected cathodically and the potential corresponds to HNO_3 reduction. In the $HNO_3 - H_2SO_4 - H_2O$ system, compositions involving the formation of NH_2OH were studied. Results: Hydroxylamine forms at maximum concentrations of HNO_3 : 13.22 or 11.6 %, H_2SO_4 : 0.08 or 31.9 %, and a water content of 86.7 or 56.5 %. Between 10 and 77 % H_2SO_4 , HNO_3 is reduced into NH_2OH also at a very low HNO_3 concentration. The formation of hydroxylamine is possible also in the system $HNO_3 - H_2O$ at 98.6 % H_2O and 1.4 % HNO_3 , and also at 86.5 % H_2O and 13.5 % HNO_3 . On the basis of the experimental data, a large laboratory electrolyzer allowing the use of 100 - 200 a (Fig. 7) was built. A viniplast cylinder (1) has ring-shaped viniplast supports (2) containing Hg (3) welded to it. A tinned Card 2/3

Effect of the cathode material ...

S/064/63/000/001/004/007
B101/B186

steel rod (4) is used for current supply. Angle brackets (5) dipping in the mercury are welded to. 4 and 5 are insulated with viniplast. The anode (7) is fixed within the diaphragm (6). For cooling, the catholyte is drawn into the vessel 8 by a vacuum (a) and is thence conducted back into the electrolyzer via coils (9) through which flowing water circulates. There are 7 figures and 1 table.

Fig. 7. Large lab electrolyzer for the production of hydroxylamine sulfate.

Fig. 7

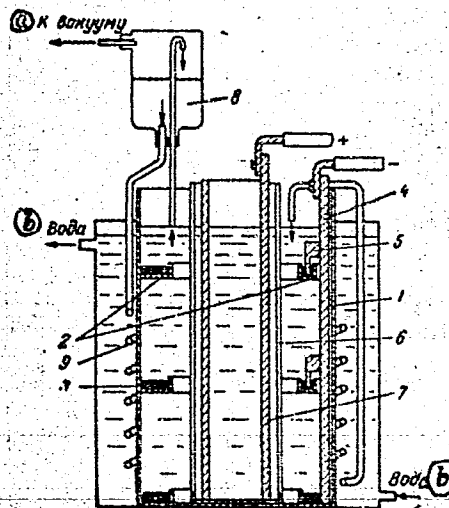

Card 3/3

KVARATSKHELIYA, R.K.

The role of sulfuric acid in the electrochemical reduction of nitric acid and hydroxylamine. Soob. AN GruzSSR 37 no.2:351-358 F '65. (MIRA 18:3)

1. Institut prikladnoy khimii i elektrokhemii AN GruzSSR. Submitted May 5, 1964.

CZECHOSLOVAKIA / Chemical Technology. Chemical Pro- H-13
ducts and Their Application--Ceramics.
Glass. Binding Materials. Concrete

Abs Jour: Ref Zhur-Khimiya, No 3, 1959, 9061

Author : Kvarda, F., Mach, O.

Inst : Not given

Title : A Review of Welding Glass Properties, Presented
in Tables and Diagrams

Orig Pub: Sklar a keramik, 1958, 8, No 6, 165-169

Abstract: The chemical composition is given, as well as
dilatometric, dielectric, mechanical, and other
properties of a large number of glass of Czecho-
slovakian and foreign manufacture used for weld-
in vacuum technique. The relationships of vis-

Card 1/2

CZECHOSLOVAKIA / Chemical Technology. Chemical Pro- H-13
ducts and Their Application--Ceramics.
Glass. Binding Materials. Concrete

Abs Jour: Ref Zhur-Khimiya, No 3, 1959, 9061

cosity to the tangential angle of dielectrical
losses to temperature is graphically represented.
The principles and methods for measuring the
given indices are presented in detail. --L. Sedov

Card 2/2

145

CZECHOSLOVAKIA/Chemical Technology. Chemical Products and
Their Application. Ceramics. Glass. Binding Materials.
Concrete. H

Abs Jour: Ref Zhur-Khim., No 10, 1959, 35718.

Author : Kvarda, F. and Res, M.

Inst :

Title : Rapid and Precise Methods for the Determination of the
Physical Properties of Glass.

Orig Pub: Sklar a Keramik, 8, No 8, 240-242 (1958) (in Czech)

Abstract: The authors describe a number of modern methods
for determining the physical properties of glasses
(the accelerated and simple method for the deter-
mination of the dilatometric characteristics of
glass, the so-called 2-wire method, the determina-

Card : 1/2

KVARDA F

COUNTRY : Czechoslovakia
CATEGORY :

RES. JOUR. : Rozhledy, No. 20 1959, No. 10074

AUTHOR : Janek, J.

TITLE : Right and Justice Methods of International of
Internal Security of USSR

ORIG. PUB. : Nihil a Poradni, 1959, 5, No 2, 100-107

ABSTRACT : Policy communication in the RIA, 1959, No 10,
10716.

CLASS:

KVARDA, F.; ONDRACEK, M.

Definition of the principal points of glass. p. 242.

SYLAR A KERAMIK. (Ministerstvo lehkeho prumyslu) Praha, Czechoslovakia,
Vol. 9, no. 8, Aug. 1959.

Monthly List of East European Accessions (EEAI) LC, Vol. 9, no. 1,
Jan. 1960.

Uncl.

Kvardakov, A. F.

436. Kvardakov, A. F. Methods of determination of the critical depth of irregular channels (in Russian). *Gidrotekhn. i Melior.* no. 7, 39-41, July 1953.
Eleven Russian methods are compared in respect to their convenience and time of computations. This article shows that Russian hydraulic engineers are unaware of progress abroad; universal and more convenient American methods are unknown or intentionally disguised. S. Kozepala, USA

GUBIN, F.F., doktor tekhn. nauk; KUPERMAN, V.L., kand. tekhn. nauk; BELYAKOV, A.A., retsenzent; KVARDAKOV, A.F., dots., retsenzent; ORLOV, V.A., kand. tekhn. nauk, dots. nauchn. red.

[Economics of water management and hydraulic construction]
Ekonomika vodnogo khoziaistva i gidrotekhnicheskogo stroitel'stva. Moskva, Stroiizdat, 1965. 302 p.

(MIRA 18:8)

1. Zamestitel' Tekhnicheskogo Soveta Gosudarstvennogo proizvodstvennogo komiteta po energetike i elektrifikatsii SSSR (for Belyakov). 2. Zaveduyushchiy kafedroy gidravliki i gidrosoruzheniy Novosibirskogo inzhenerno-stroitel'nogo instituta im. V.V. Kuybysheva (for Kvardakov).

L 32110-55 EST(1)/FCC CW

ACCESSION NR: AR5003746

B/0169/64/000/012/0010/0011

SOURCE: Ref. zh. Geofiz., Abs. 12876

AUTHORS: Kvartskheliya, I. F.

TITLE: Aerological investigations in the Transcaucasus

CITED SOURCE: Aerologicheskiye issledovaniya v Zakavkas'ye, L., Gidrometsizdat, 1964, 245 str.

TOPIC TAGS: aerological sounding, air mass, atmospheric turbulence, atmospheric stratification, jet stream, diurnal variation, tropopause, upper atmosphere

TRANSLATION: The monograph contains the results of aerological investigations carried out in the Transcaucasus, principally in 1938--1952. Chapter I contains a brief description of the climate of the free atmosphere over the Transcaucasus. Chapter II describes the regime of the principal meteorological elements (air temperature, pressure distribution, wind, humidity, cloudiness) up to an altitude of 15 km. Chapter III reports results of an investigation of the diurnal variation and variability of meteorological elements. Chapter IV gives the results of an analysis of the different temperature regimes in the free atmosphere and in high-

Card 1/3

L 32110-65

ACCESSION NR: AR5009746

mountain stations during the morning hours and afternoon, and also results of an investigation of the dependence of the temperature difference between the free atmosphere and the high-mountain stations on the vertical motions of the air, cloudiness, vertical temperature gradient, and snow cover. Chapter V describes the influence of the main Caucasus range on the temperature regime of the free atmosphere over the central part of the Transcaucasus. Chapter VI contains the structural features of the construction of the tropopause, discusses questions concerning the genesis of powerful isothermal and inversion layers in the upper half of the troposphere, and describes the character of the tropopause in jet flows and in planetary high-altitude frontal zones. Under the conditions of the Transcaucasus, the tropospheric frontal sections and the associated isothermal and inversion layers are caused by powerful cold intrusions and, to an equal degree, by the propagation of warm air masses. Chapter VII gives some characteristics of jet streams (classification, recurrence, average altitudes, vertical extent, average and maximum velocities, wind shifts). Chapter VIII considers the conditions for the formation of jet streams with abrupt (equal to or exceeding 12 m/sec per km) vertical shifts of wind velocity. It is established that most frequently jet streams are observed over the Transcaucasus in the summer and in the first half of the fall, while the secondary maximum occurs in the

Card 2/3

L 32110-65

ACCESSION NR: AR5005746

winter. On the average, the axes of the jet streams are located directly under the tropopause. The maximum wind velocity on the axis of a jet stream can reach 60-65 m/sec. Sharp positive vertical shifts in the wind velocity in jet streams are observed in tropospheric frontal sections, and not at altitudes that are directly adjacent to the axis of the jet streams. Sharp negative shifts are observed not at an altitude of the jet-stream axis, but above it. Jet streams are connected in all cases with phenomena that cause the formation of frontal sections and high-altitude frontal zones. It is concluded that the

connected in all cases with phenomena that cause the formation of frontal sec-
tions and high-altitude frontal zones. It is concluded from this that there are
no frontless jet streams in the atmosphere. Bibliography, 199 titles. H.
Davydov.

SUB CODE: ES

ENCL: 00

Card 3/3

SOV/112-59-2-2993

Translation from: Referativnyy zhurnal. Elektrotehnika, 1959, Nr 2, p 106 (USSR)

AUTHOR: Kvartal'nov, B. V.

TITLE: Analysis and Calculation of Transients in an Induction-Motor Drive With an Impact Load and Allowance for Elastic Deformation (Analiz i raschet perekhodnykh protsessov v elektroprivode s asinkhronnymi dvigatelyami pri udarnoy nagruzke s uchetom uprugikh deformatsiy)

PERIODICAL: Nauchno-tekhn. inform. byul. Leningr. politekhn. in-ta, 1957, Nr 11, pp 104-111

ABSTRACT: Electromechanical transients are analyzed that occur when a load is suddenly thrown on in a driving system that includes a mass and elastic members whose deformation obeys Hooke's law. This case is practically conceivable in such machines as dredges, some types of cranes, and hoisting mechanisms of hydraulic gates; the problem is adapted to the construction of the latter. A differential equation that describes the transients can hardly be

Card 1/2

SOV/112-59-2-2993

Analysis and Calculation of Transients in an Induction-Motor Drive With an

solved analytically. Hence, a grapho-analytical method is suggested. The induction-motor mechanical-characteristic curve is replaced by three segments of a straight line; an equation is set up and solved for each segment. To verify the method suggested, two experimental outfits were assembled in a laboratory of the Leningrad Polytechnic Institute which simulated the above electro-mechanical system. The records of motor rpm variations presented in the article show good agreement with the values calculated by the above method.

A.I.F.

Card 2/2

AUTHOR: Kvartal'nov, B.V., Assistant SOV/144-58-8-15/18

TITLE: Influence of the Mechanical Characteristics of an Asynchronous Motor on the Dynamic Forces During Wedging of Mechanisms of Hydraulic Structures (Vliyaniye mekhanicheskoy kharakteristiki asinkhronnogo dvigatelya na dinamicheskoye usileniye pri zaklinivanii mekhanizmov gidrosooruzheniy)

PERIODICAL: Izvestiya Vysshikh Uchebnykh Zavedeniy, Elektro-mekhanika, 1958, Nr 8, pp 119-127 (USSR)

ABSTRACT: In the practical operation of hydraulic structures, the moving organ, which is linked with the drive mechanism by means of an elastic element, may become suddenly wedged, as a result of falling into the slots of foreign bodies, icing, etc. If the driving motor is not immediately disconnected for any reason, its further running will bring about a deformation of the elastic coupling element. After reaching a critical torque the speed of the (crane-type) asynchronous motor will drop to zero and this will correspond to a maximum value of the linear deformation of the elastic coupling element. If at zero r.p.m.

Card 1/6

SOV/144-58-8-15/18

Influence of the Mechanical Characteristic of an Asynchronous Motor on the Dynamic Forces During Wedging of Mechanisms of Hydraulic Structures

the moment of the forces of the elastic deformation is higher than the sum of the moments of the motor and the friction, the motor will start moving in the opposite direction. The system will be in a state of oscillation up to the establishment of full equilibrium of the torques. In spite of the fact that in such mechanisms special damping devices are used, high alternating loads will occur in the traction organ. The resulting dynamic forces will be transmitted to the supporting beams and other parts of the structure. Designers of the mechanical part of the system and of the electric drives are interested to know the influence of the mechanical characteristic of the motor and the parameters of the drive on the magnitude of the dynamic forces and practical measures for limiting these effectively. From 1951 onwards, a number of engineers of MPK and LPK, "Gidrostat'proyekt", A.Ya. Zykov (LETI) and others have been working on this problem. The proposed methods of calculation of the dynamic forces were not confirmed by practical experience

Card2/6

SOV/144-58-8-15/18

Influence of the Mechanical Characteristic of an Asynchronous Motor on the Dynamic Forces During Wedging of Mechanisms of Hydraulic Structures

and, with the exception of A. Ya. Zykov (Ref 3), they did not take into consideration the influence of the parameters of the drive and the magnitude of the dynamic forces. Solution of this problem is complicated due to the non-linear nature of the torque of the motor and the static moment which has a discontinuity at zero r.p.m. For this reason, the author of this paper proposes to sub-divide the range approximately into a number of sections, in each of which the static moment and the moment of the motor can be assumed as being linear (Figure 1, p 120). The transient electro-magnetic processes in the circuits of the asynchronous motor are not taken into consideration and therefore the here proposed method is recommended only for cases in which the drive slows down a little during the process of wedging (a drive with a high moment of gyration and a low rigidity of the elastic element). In deriving the differential equations it is assumed that the deformation

Card3/6

SOV/144-58-8-15/18

Influence of the Mechanical Characteristic of an Asynchronous Motor on the Dynamic Forces During Wedging of Mechanisms of Hydraulic Structures

of the elastic element is linear and complies with the Hook law. The deformations of the shafts and the moment of inertia of the pulling organ are disregarded. Figure 2 shows a sketch of the simplified kinematic scheme of the drive during the process of wedging. The analytically derived relations have been verified on a test rig and the obtained experimental results are compared with calculated values in a graph, Figure 4, p 125. The here proposed method permits calculating the dynamic forces during the process of wedging and also selecting the parameters of the drive on the basis of a pre-determined maximum force. Substitution of the characteristics of the motor by three sections of straight lines provides a relatively high accuracy of calculation of the dynamic forces; substitution of the characteristics by eight sections of straight lines instead of three results in a difference of only 3%. For limiting dynamic forces, the author recommends changing the shape of the characteristic of the motor whereby the critical torque

Card4/6

SOV/144-58-8-15/18

Influence of the Mechanical Characteristic of an Asynchronous Motor
On the Dynamic Forces During Wedging of Mechanisms of Hydraulic
Structures

should be reduced to $(1.7 - 1.9) \times M_{\text{rated}}$ and at zero
r.p.m. the torque should equal the torque of the
"natural characteristic" or it should exceed it by
10-20%. In motors with short-circuited rotors, the
voltage fed to the stator should be reduced as much as
possible. The author recommends that the inertia moments
of the rotating parts should be made as low as possible
and a driving motor should be used of a rating low enough
so as not to have any power reserves. In the paper, the
author did not consider synchronous operation nor did
he consider the variant of feeding the motors through
a pre-magnetised reactor for the purpose of reducing the
critical torque. There are 7 figures, 1 table and
3 Soviet references.

Card5/6

SOV/144-58-8-15/18
Influence of the Mechanical Characteristic of an Asynchronous Motor
on the Dynamic Forces During Wedging of Mechanisms of Hydraulic
Structures

ASSOCIATION: Kafedra elektrifikatsii promyshlennykh predpriyatiy
Leningradskogo politekhnicheskogo instituta
(Chair for Electrification of Industrial Undertakings
of Leningrad Polytechnical Institute)

SUBMITTED: February 22, 1958

Card 6/6

S/194/61/000/009/023/053
D209/D302

AUTHOR: Kvartal'nov, B.V.

TITLE: Test of an inductive-capacitive measuring element
of a frequency element

PERIODICAL: Referativnyy zhurnal. Avtomatika i radioelektronika,
no. 9, 1961, 36, abstract 9 V296 (Nauchno-tekhn.
inform. byul. Leningr. politekhn. in-t, 1960, no. 8,
73-78)

TEXT: A sensitive frequency measuring element (ME) in the
form of a quadripole with resonance properties for frequency deter-
mination is analyzed. The test results of the inductive-capacitive
ME are supplied. The scheme consists of two resonance circuits.
Voltages across inductive resistors in these circuits are rectified
by bridge rectifiers. On adding the rectified voltages, an output
voltage equal to zero for a given frequency can be obtained. With
the deviation of input frequency from the nominal value, a signal

Card 1/2

Test of an inductive-capacitive...

S/194/61/000/009/023/053
D209/D302

is obtained at the output of the corresponding sign and proportion-
al to the frequency change. The following constructional and com-
ponent parameters of ME details are provided: Transformer, chokes
with controlled gap, capacities and resistances, valves, as well as
graphs of the experimental test results. The developed ME has a
linear characteristic within the limits of ± 3 cycles with a slope
of 22 V/cycle. On decreasing the regulated frequency band to ± 0.5
 ± 1 cycle a slope of 60 \pm 80 V/cycle could be obtained. Dead band:
0.04 \pm 0.06 cycles. 7 figures. 3 references. [Abstracter's note:
Complete translation]

Card 2/2

KVARTAL'NOV, Boris Vasil'yevich; DRANNIKOV, V.G., red.

[Automation of machinery manufacturing processes; textbook for the course "Economics and organization of the machinery industry."] Avtomatizatsiia mashinostroitel'nogo proizvodstva; uchebnoe posobie po spetsial'nosti "Ekonomika i organizatsiia mashinostroitel'noi promyshlennosti." Leningrad, Leningr. politekhn.in-t, 1962. 213 p. (MIRA 17:3)

FETISOV, V.V. (Leningrad); KVARTAL'NOV, B.V. (Leningrad); IVANOV, Yu.Ya.
(Leningrad); PINCHUK, V.M. (Leningrad); TIKHOMIROV, A.N.
(Leningrad)

Generator-motor inverse d.c. to a.c. converter. Izv. AN SSSR.
Otd. tekhn. nauk. Energ. i avtom. no.4:32-39 J1-Ag '62.

(Electric current converters) (MIRA 15:8)

KVARTAL'NOV, B.V.

Transient processes in the electric drive of a drilling rig when the drilling tool is being pinched and the drilling column is being stuck. Izv.vys.ucheb.zav.; neft' i gaz 6 no.9:19-24 '63.
(MIRA 17:2)

1. Leningradskiy politekhnicheskii institut im. M.I.Kalinina.

KVARTAL'NOV, B.V. inzh.; PINCHUK, V.M., inzh.; TIKHOMIROV, A.N., inzh.

Automatic excitation control system of a synchronous machine
operating in motor and generator modes. Izv. vya. ucheb.zav.;
energ. 7 no. 4:1-6 Ap '64. (MIRA 17:5)

1. Leningradskiy politekhnicheskii institut imeni M.I.Kalinina.
Predstavlena kafedroy elektroprivoda i avtomatizatsii promyshlen-
nykh ustanovok.

KVARTAL'NOV, B.V.; SEMENOV, I.M.; SIDEL'NIKOV, B.V.

Calculation of transients in the saturable reactors of a regulated asynchronous electric drive. Trudy LPI 240: 9-67 '64. (MIRA 17:11)

KVARTAL'NOV, Boris Vasil'evich. Prinsipal uchastiye: BOCHARO,
Yu.I., inzh.; PRIKHNO, V.I., inzh.; SAVININ, Yu.A., kand.
tekhn. nauk; VLASOVA, Z.V., red.

[Dynamics of automated electric drives with resilient
mechanical couplings] Dinamika avtomatizirovannykh
elektroprivodov s uprugimi mekhanicheskimi svyaziami.
Moskva, Energiia, 1965. 87 p. (Biblioteka po avtoma-
tika, no.139) (MIRA 18:8)

KVARTALOV, D. (Moskva).

More about keeping records of tenant's payments. Bukhg.uchet 16
no.2:43-47 F '57. (MLRA 10:2)

1. Starshiy konsul'tant otдела metodologii ucheta Tsentral'noy
bukhgalterii Ministerstva putey soobshcheniya.
(Rent) (Municipal services)

KVARTALOV, D. (Moskva).

Keeping records of repayments of loans by builders of private
dwellings. Bukhg. uchet 15 no.2:38-41 F '58. (MIRA 11:3)
(Dwellings--Finance)

KVARTEL'NOV, B.V.

Transient processes in d.c. drives taking into account resilient
deformations in mechanical links. Trudy LPI 240:18-25 '64.
(MIRA 17:11)

KVARTENKO, A.M.

Automatizing pug mills. Ogneupery 18 no.3:128-131 '53. (MIRA 11:10)

(Mixing machinery) (Automatic control)

KVARTENKO, A.S., inzh.

Bending and cutting tools for working reinforcement steel. Mekh.
stroi. 19 no.8:28-29 Ag. '62. (MIRA 16:7)

(Concrete reinforcement)
(Machine tools)

KVARTENKO, A.S., inzh.; KALISTOV, I.A., inzh.; SOKOLOV, A.M., inzh.; CHUVAYEV,
Yu.P., inzh.

The S-573 unit for the pneumatic-tube transportation of concrete
mixes. Stroi. i dor. mashinostr. 4 no.11:16-17 N '59 (MIRA 13:3)
(Pneumatic-tube transportation) (Concrete)

S/135/61/000/001/017/018
A006/A001

AUTHORS: Kyartin, I.I., Kalashnikov, F.I., Engineers

TITLE: On Welding in Water Vapor Atmosphere

PERIODICAL: Svarochnoye proizvodstvo, 1961, No. 1, p. 48

TEXT: Welding of 1 - 2 mm thick sheet steel (St.3) in water vapor was investigated at the Odessa Plant of Food-Stuffs Machinebuilding with the A-547r semi-automatic machine, using Sv-08 wire. To a 1.5 mm thick netted pipe, a 2 mm thick steel cone was welded with 120 - 150 amps current, 20 - 25 v arc voltage. Some deficiencies of the process such as considerable heating of the burner and butting of the wire against the nozzle edge when leaving the tip were eliminated by modernizing the burner design. The method of supplying dry vapor to the welding zone was also improved. In the vapor generator designed by the Plant imeni 15-letiyе IKSMU the electric interrupter was replaced by a micro-interrupter, a settling tank for the condensate was devised and a vapor superheater was installed. The mechanical properties of the weld joints were 42 kg/mm² ultimate strength; 6.9 - 7 kgm/cm² toughness and a bending angle of 160 - 180°. The problem is set

Card 1/2

BRUSILOVSKIY, D.A.; BULGAKOV, L.N.; GENIS, B.M.; KVARTIN, L.M.;
KRASOVSKIY, Ye.S.; MIKHAYLOV, D.I.; NATOCHANNYY, A.S.; NIKOL'SKIY,
V.N.; POPOV, M.P.; SIGODZINSKIY, A.A.; SKOMOROSHKIN, A.F.;
CHASOVNIKOV, G.V.; DERBISHER, A.V., kand. ekon. nauk, red.;
DULKIN, N.A., spets. red.; BONDAROVSKAYA, G.V., red.; TORSHINA,
Ye.A., tekhn. red.

[Overall automation and modernization of equipment and production
processes at the First State Bearing Plant] Kompleksnaya avtoma-
tizatsiia i modernizatsiia oborudovaniia i protsessov proizvodstva
na Pervom gosudarstvennom podshipnikovom zavode. Moskva, TSentr.
biuro tekhn. informatsii, 1959. 84 p. (MIRA 15:1)

1. Russia (1917- R.S.F.S.R.) Moskovskiy gorodskoy ekonomicheskii
administrativnyy rayon. Sovet narodnogo khozyastva.
(Moscow—Bearing industry) (Automation)

KVARTIR, Sh.

Combat traditions are still alive. Pozh.delo 7 no.9:19 S '61.

(MIRA 14:11)

1. Nachal'nik karaula 17-y pozhar'noy chasti, Leningrad.
(Firemen)

KVARTOVKINA, L.K.

Organization of nutrition at an athletic training camp [with summary
in English]. Vop.pit. 17 no.3:13-16 My-Je '58. (MIRA 11:6)

1. Iz kafedry gigyeny zav. - prof. L.G.Zhitomirskiy) Rostovskogo
meditsinskogo instituta.

(ATHLETICS,

nutrition in train. camp (Rus))

(NUTRITION,

in athletic train camp (Rus))

POSLEDOVICH, M., KVARTSEV, M.

Collective Farms

Blossoming land. Mol. kolkh. no. 2, 1952.

Monthly List of Russian Accessions, Library of Congress, August 1952. Unclassified.

CA

KVARTSKHAVA, I. F.

Investigation of the time lag of gas-filled photoelectric cells. I. Kvartskhava and P. Timofeev. *Tech. Phys. U. S. S. R.* 17-400-7R(1934) (in English); *J. Tech. Phys. (U. S. S. R.)* 4, 1678-1706(1934) (in Russian).--Time lag is due to the time of passage of the positive ions between electrodes. A theory is developed to explain the lesser time lag of Cs than of K cells. Argon-filled cells should have a lower time lag than He- or Ne-filled cells. F. H. R.

ASB-SLA METALLURGICAL LITERATURE CLASSIFICATION

1	2	3	4	5	6	7	8	9	10	11	12	13	14	15	16	17	18	19	20	21	22	23	24	25	26	27	28	29	30	31	32	33	34	35	36	37	38	39	40	41	42	43	44	45	46	47	48	49	50	51	52	53	54	55	56	57	58	59	60	61	62	63	64	65	66	67	68	69	70	71	72	73	74	75	76	77	78	79	80	81	82	83	84	85	86	87	88	89	90	91	92	93	94	95	96	97	98	99	100
---	---	---	---	---	---	---	---	---	----	----	----	----	----	----	----	----	----	----	----	----	----	----	----	----	----	----	----	----	----	----	----	----	----	----	----	----	----	----	----	----	----	----	----	----	----	----	----	----	----	----	----	----	----	----	----	----	----	----	----	----	----	----	----	----	----	----	----	----	----	----	----	----	----	----	----	----	----	----	----	----	----	----	----	----	----	----	----	----	----	----	----	----	----	----	----	----	----	----	-----

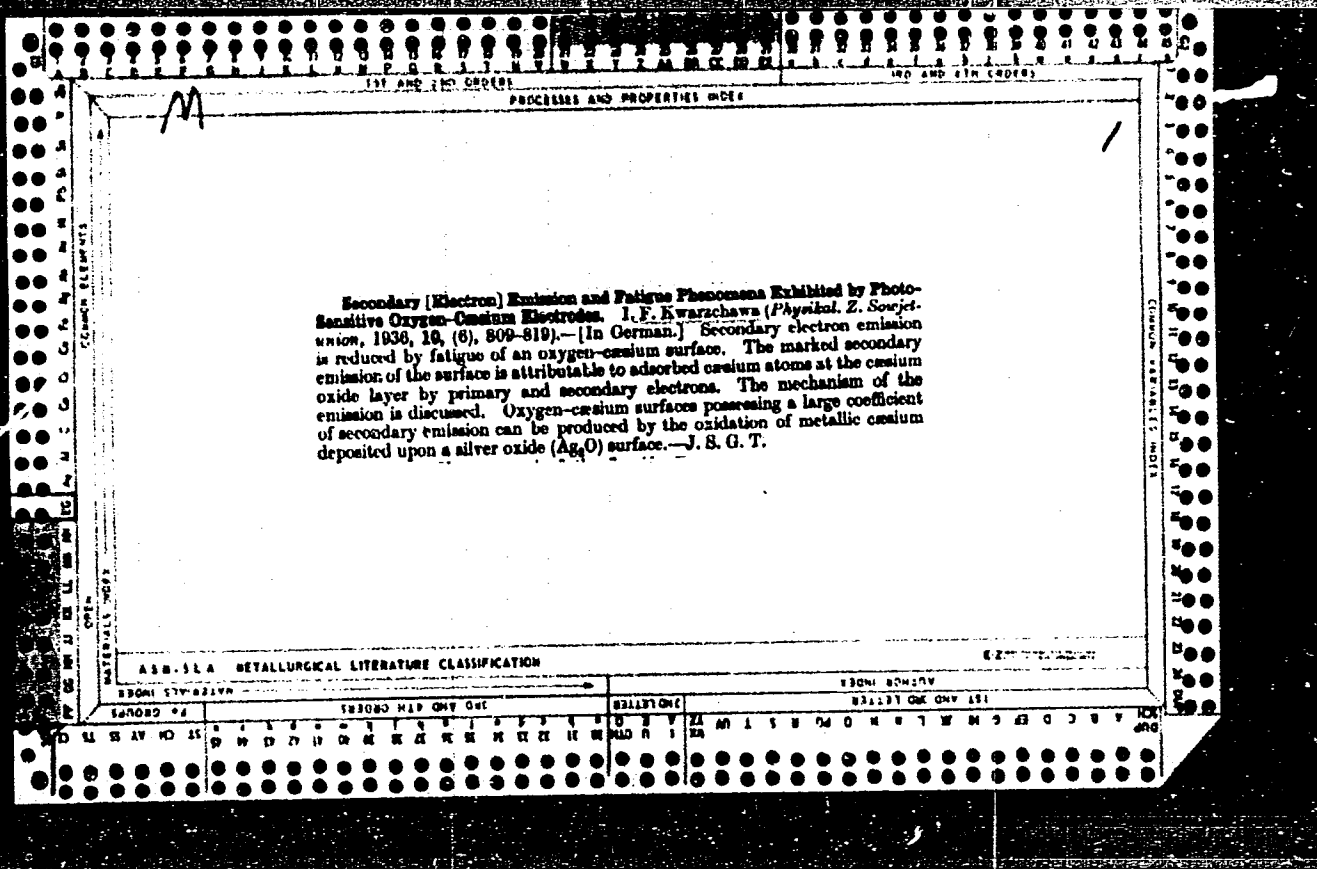

KVARTSKHAVA, I. F. 5
 CA
 Change of conductivity of Al₂O₃ upon electron bombardment. I. F. Kvarzhava. *Dokl. Akad. Nauk S.S.S.R.*, Ser. Phys. 6, 373(1944).—In the course of the study of electronic excitation within the emitting layer by primary electrons, K. utilized Al oxide layers, which were sufficiently adhesive dielectrics to produce substantial electric gradients within the layers, excited by an added stream of slow electrons. Large numbers of excited electrons can be formed within the oxide film by a beam of relatively rapid electrons; at field gradients of 10⁵ v./cm., or higher, a process occurs which leads to increased "dark" cond. of the oxide film and decreased effect of electron excitation. G. M. Kosolapoff

Sov. Phys. & Acoustics, 95 5-55R

ASS-SLA METALLURGICAL LITERATURE CLASSIFICATION
 1 2 3 4 5 6 7 8 9 10 11 12 13 14 15 16 17 18 19 20 21 22 23 24 25 26 27 28 29 30 31 32 33 34 35 36 37 38 39 40 41 42 43 44 45 46 47 48 49 50 51 52 53 54 55 56 57 58 59 60 61 62 63 64 65 66 67 68 69 70 71 72 73 74 75 76 77 78 79 80 81 82 83 84 85 86 87 88 89 90 91 92 93 94 95 96 97 98 99 100

117 AND 118 CORDS

PROCESSED AND PROPERTY INDEX

115 AND 4TH ORDER

U

Transition effect of cosmic rays in lead. I. A. I. Alkhimov, I. Kyars'kaya, and S. Zurnban (Phys. Tech. Inst. Acad. Sci. U.S.S.R.). *J. Phys. (U.S.S.R.)* 9, No. 1, 63-6(1945).--Measurements were made at different depths in Lake Kara-Oel, elevation 3225 m. The absorption in water of the shower-producing component is different from that of the soft component. Expts. with Al screens 0 to 3 mm. thick between the Pb screen and chamber wall showed that absorption reaches a max. at 6 to 12 mm. of Pb, depending on the thickness of the Al screen. N. L. Gerhard

cond. Physics & Astrophysics, AS 5512

OPEN

CHAMBER ELEMENT

MATERIALS INDEX

ABB. 55A METALLURGICAL LITERATURE CLASSIFICATION

FROM SOURCE

115 AND 4TH ORDER

117 AND 118 CORDS

FD-1822

USSR/Physics - Resistance

Kvartskhava, I.F.

Card 1/1

Pub 146-7/25

Author : Bondarenko, V. V.; Kvartskhava, I. F.; Plyutto, A. A.; Chernov, A. A.

Title : Resistance of metals in the case of large current densities

Periodical : Zhur. eksp. i teor. fiz. 28, 191-198, February 1955

Abstract : The authors present the results of an investigation into the dependence of the resistance of certain metals upon current density. They compare the experimental curves representing the dependence of the resistance of copper, silver, platinum, etc. upon the magnitude of the energy introduced with the curves computed from tabular data. They establish that for these metals Ohm's law holds up to current densities of about 10^7 amperes per square centimeter. Seven references; e.g. Ye. S. Borovik, DAN SSSR, 91, 771, 1953.

Institution: --

Submitted : February 16, 1954

KVARTSKHAYA, I. F.

Resistance of metals for large current densities V. V. P. H. ⑤
Bondarenko, I. F., Kvartskhaya, I. A., Piatto, and A. A. P. H.
Zhurnal Sverdlovskogo gos. univ. Ser. Fiz.-mat. nauki, 1963, No. 1, p. 153. See C.A.
50, 30294. R. M. R.

RAW

KVARTSKHAYA, I. F.

met

Electric explosion of metallic wires. I. F. Kvartskhaya, A. A. Plyuto, A. A. Chernov, and V. V. Bondarenko. *Zhur. Eksp. i Teor. Fiz.* 30, 49-53 (1956). - Quant. balance of energy in elec. explosions of wires 0.10 mm. in diam. and 15 cm. long in air, vacuum, water, and solid insulators was investigated by current and voltage oscillography and by simultaneous shadow photography. With wires embedded in solid or liquid medium the temp. range of 100,000-150,000°K. is reached. In K (in glass capillary), Cu, and W wires within several microsec. during the process of explosion, the wire receives the initial impulse of the discharge, and the current begins to decrease, $di/dt < 0$; this causes an over-voltage in the wire. At the end of the first impulse the current and di/dt approach zero; this results in a "current pause," lasting up to several hundred microsec. A second

impulse is characterized by much greater current and lower voltage than those of the first impulse; this indicates an arc discharge. The oscillograms of Al, Ag, and Au wires are similar to that of Cu wire; those of W, Mo, Fe, Ni, and Ni-Cr are similar to that of Pt wire, characterized by the region of the first impulse. Rpts. with wires embedded in poly-(methyl methacrylate) and submerged in water showed that shape and magnitude of the first impulse are independent of the surrounding medium. A. P. Kutloby

KVARTSKHAVA, I. F.

Category : USSR/Photoeffect - Electron and Ion Emission

H-2

Abs Jour : Ref Zhur - Fizika, No 1, 1957, No 1645

Author : Kvartskhava, I. F.

Title : ~~Concerning Articles~~ by S.E. Khaykin, S.V. Lebedev and L.N. Borodovskaya
Published in ZhETF in 1954 -- 1955.

Orig Pub : Zh. eksperim. i teor. fiziki, 1956, 30, No 3, 621-623

Abstract : Checking against the results of her own experiments, the author states that the anomalies observed by Khaykin and others (Referat. Zh. Fizika, 1955, 5066; 1956, 4519, 7532, 10747) in the behavior of the resistance and of the electron emission of metals when heated with pulses of very high currents are caused not by the substance changing over to an anomalous state, but by many experimental errors, such as the failure to take into account the inductive distortion of the oscillograms, ignoring the possibility of a shunting discharge being formed along the wire in the tungsten vapor, and failure to take into account known deviations from the "three-halves" law, caused by the magnetic field of the current.
Bibliography, 9 titles

Card : 1/1

~~KVARTSKHAVA, I.F.~~ KVARTSKHAVA, I.F.

SUBJECT USSR / PHYSICS CARD 1 / 2 PA - 1768
AUTHOR KVARCCHAVA, I.F., BONDARENKO, V.V., MELADZE, R.D., SULADZE, K.V.
TITLE The Electric Explosion of Wires in the Vacuum.
PERIODICAL Zhurn. eksp. i teor. fis, 31, fasc. 5, 737-744 (1956)
Issued: 1 / 1957

The present work contains a report on the results obtained by tests concerning the explosion of wires in a vacuum of $\sim 10^{-5}$ mm column of water in a sufficiently large chamber. A further reduction of pressure exercised no influence on the observed phenomena.

Test methods and results: For the electric scheme of the test order see V.V. BONDARENKO et al. Zhurn. eksp. i teor. fis, 28, 191 (1955). The section through a chamber is described by a drawing. Tests were carried out mainly with copper wires. The entire capacity of the condenser pile was $4 \mu F$ and the inductivity of the circuit of the explosion was 1,2 microhenry. For the investigation of the condensation of the condensed products the wire was surrounded by a coaxial aluminium screen. The entire explosion was photographed in the light of the discharge itself in a position vertical to the axis of the wire; the photographs obtained are attached. The condensed product has a stripe-like structure and height along the entire length of the screen. The stripes are vertical to the wire and the height of the condensed substance is nearly equal to the length of the wire. This points in the direction of a radial distribution of the vapors of the wire. The height of the condensed substance has two unequal maxima and two minima. The products of the electric explosion extend, indepen-

Zyrn. eksp. i teor. fis, 31, fasc. 5, 737-744 (1956) CARD 2 / 2

PA - 1768

dent of the original shape of the wire, vertical to every point of the surface. With respect to the direction of the extension of the products of the explosion this reminds us of the ordinary explosion of very elongated charges. Under the conditions investigated only the front of the vapor flow moves in the high vacuum, whereas the remaining parts of the flow move in a deteriorated vacuum. Nevertheless, the condensation products remain within strict limits and give a clear illustration of the strata-like structure of the vapor flows. This is possible only in the case of high radial velocities of the vapor flows. These velocities amounted to $\sim 2 \cdot 10^5$ cm/sec on the occasion of the tests under investigation. If the diameter of the wire is reduced, the radial dimensions of the luminescent channels are reduced as well. According to the authors' opinion, the luminescent channels are caused mainly by the radial motion of the vapors of the wire in the strong magnetic field of the current. The channels are produced and exist only within the first half-period of amperage. Further details are discussed. The causes of the phenomena described are discussed, but at present they are still only a rough approximated description of reality.

INSTITUTION:

~~KVARTSKHAYA, I.F.~~ ~~KVARTSKHAYA, I.F.~~
 SUBJECT USSR / PHYSICS CARD 1 / 2 PA - 1871
 AUTHOR KVARCCHAVA, I.F., BONDARENKO, V.V., PLJUTTO, A.A., CERNOV, A.A.
 TITLE The Oscillographic Determination of the Energy of the Electric
 Explosion of Wires.
 PERIODICAL Zurn. eksp. i teor. fis., 31, fasc. 5, 745-751 (1956)
 Issued: 1 / 1957

These oscillographic investigations took place within a relatively wide range of voltages on the condenser of the explosion circuit. By means of a "current resistance" (V.V. BONDARENKO et al., Zurn. eksp. i teor. fis., 28, 191 (1955)) amperage oscillograms were obtained which are free from all inductive distortions. The energy introduced into the wire was computed solely on the basis of the amperage oscillogram, the known initial voltage on the condenser, the capacity of the condenser, and the inductivity of the induction circle. The electric explosion was caused by means of a discharge by the wire passing through a high tension condenser. The wiring diagram and the method of the experiment is described by the above cited work. Above all, copper wires were investigated because here the basic features of the electric explosion were the most distinct. These wires were 60 mm long and had diameters of 0,05; 0,1 and 0,15 mm. The capacity of the condenser battery amounted to 2,5 μ F, the initial voltage was from 5 to 40 kV, and inductivity 0,4 and 4,2 microhenry.

If the initial voltage U_0 is increased or if L is diminished, the first current pulse which causes the electric explosion of the wire, becomes shorter

Zurn. eksp. i teor. fis., 31, fasc. 5, 745-751 (1956) CARD 2 / 2

PA - 1871

and higher. In the case of relatively low values of U_0 a "discharge pause" occurs after the first current pulse in the explosion circuit, which is often ended by a second, mostly stronger, current pulse. In the case of high values of U_0 this discharge pause does not occur, and amperage, after passing through a minimum that differs somewhat from zero, again begins to grow. From two amperage oscillograms it follows that the inductive and Ohm-voltage drop are of the same order. The energy $E(t)$ introduced during the time t (calculated from the beginning of the discharge) into the wire amounts to:

$$E(t) = (C/2) [U_0^2 - (U_0 - \Delta U)^2] - U_0 \Delta Q - \Delta Q^2 / 2C.$$
 Here ΔU denotes the reduction of the initial voltage U_0 during the time t and $\Delta Q = C \Delta U$ - the

charge leaving the condenser during the same period. In the case of relatively low voltages on the condenser the electric explosion shows no anomalies whatever in the connection between the introduced energy and resistance of the wire. However, in the case of high voltages on the condenser the resistance of the wire no longer depends univocally on the energy liberated in the wire. This may be explained by the discharge of energy from the wire in the course of the explosion. The contracting effect of the magnetic field of the current limits the attainable values of current density particularly in the case of thin wires.

INSTITUTION:

KVARTSKHAVA, I F.

AUTHOR PLYUTTO A.A., KERVALIDZE D.N., KVARTSKHAVA I.F., 89-8-12/26
 TITLE A Spark Source of Multiple -Charged Ions.
 (Iskrovy istochnik mnogozaryadnykh ionov- Russian).
 PERIODICAL Atomnaya Energiya, 1957, Vol 8, Nr 3, pp 153-156 (U.S.S.R.)
 ABSTRACT By means of a spark source, which is described in detail, it is possible to obtain multiply charged ion fluxes of high intensity. As a current source for the formation of the spark a condenser with 10^3 to 10^5 nF, 10-70 kV, average spark current 10^2 - 10^4 A was used. For sucking off the ions condensers with 10^4 - 10^6 nF and 15-70 kV were used. The ions were analyzed by means of a Thompson parabola - mass spectrograph. The following ion currents (not focussed) were obtained:
 $C^{+3}, C^{+4}, N^{+3}, N^{+4}, O^{+3}, O^{+4} \sim 10$ to several 100 m A
 $N^{+5}, O^{+5} \sim 100 \mu A$ to several m A
 $O^{+6} \sim 100 \mu A$.
 $Cu^{+6}, Cu^{+7}, Ni^{+6}, Ni^{+7} \approx 100 \mu A$.
 By fitting a magnetic focussing device focussed ion currents (30 kV suction voltage) were obtained:
 $H^{+1} \quad 10$ m A
 $H^{+2} \quad 1$ m A
 $C^{+4} \quad 6$ m A
 $C^{+3} \quad 15$ m A.
 Card 1/2 (3 illustrations and 3 Slavic references).

24(3)

AUTHORS: Kvartskhaya, I. F., Bondarenko, V. V., SOV/56-35-4-12/52
Meladze, R. D., Suladze, K. V.

TITLE: Electric Explosion of Spiral Wires in Vacuum
(Elektricheskiy vzryv spiral'nykh provolok v vakuume)

PERIODICAL: Zhurnal eksperimental'noy i teoreticheskoy fiziki, 1958,
Vol 35, Nr 4, pp 911-916 (USSR)

ABSTRACT: In two earlier papers the authors already investigated electric wire explosions in a vacuum (Refs 1, 2). The investigation of the phenomena of luminescence accompanying the explosion was carried out photographically; the experimental scheme used has already been described (Ref 2). For the wire explosion a battery condenser with a capacity of 4.8 μ F and a working voltage of 50 kV was used. In the present paper only the results of investigations are given, while as to the investigations themselves references 1 and 2 are mentioned. Results are discussed on the basis of the reproduced photographs. Figure 1 shows 2 photos of explosions of cylindrical copper wire spirals and 2 of sinusoidally curved wires. Figure 2 shows the photo-

Card 1/3

Electric Explosion of Spiral Wires in Vacuum

SOV/56-35-4-12/52

graph of an explosion on a copper wire ring, of an explosion on a straight Cu-Al wire, and one of mirror scanning. All data concerning these photographs are given. It was found that, in the case of wire explosions in a vacuum, also glow effects are observed besides the phenomenon of the current tubes. This phenomenon is a consequence of the motion of explosion products through the magnetic field of the current (during the discharge an additional electric field $\vec{E} = \frac{1}{c} [\vec{v} \times \vec{H}]$ is formed, where \vec{v} denotes the velocity of the explosion products in the \vec{H} -field, and c the velocity of light in the vacuum); the former effect is considered to be a consequence of reciprocal interaction among the currents of the explosion products. The velocity of the explosion front is determined by scanning the explosion with a mirror as amounting to 10^6 cm/sec. It is also found that during the very short time of the explosion, thermal insulation of the plasma is possible by means of a strong magnetic field. In conclusion, the authors endeavor to give a

Card 2/3

. Electric Explosion of Spiral Wires in Vacuum

SOV/56-35-4-12/52

qualitative explanation of the phenomena observed.
There are 3 figures and 8 Soviet references.

SUBMITTED: May 10, 1958

Card 3/3

KVARTSKHAVA, I. F.

"Acceleration of Plasma"

report presented at the Conference on High Energy Accelerators and Instrumentation,
14-19 Sep 1959. Geneva. (CERN -IUPAP)

84560

10.8000 2507 only

S/057/60/030/011/003/009
B006/B054

26.2321
AUTHORS:

Kvartskhava, I. F., Kervalidze, K. N., and Gvaladze, Yu.S.

TITLE:

Instability of an Inductive (Theta) Pinch /9

PERIODICAL:

Zhurnal tekhnicheskoy fiziki, 1960, Vol. 30, No. 11,
pp. 1321-1328

TEXT: The authors studied one of the forms of plasma instability with which an eruption of local plasma formations from the surface of a strongly compressed pinch can be observed. They call this form "eruptive instability". The authors had already reported on this subject at the 4th International Conference on Ionization Phenomena in Gases (Upsala, 1959). The investigations were made by means of a series of slow-motion pictures ($2 \cdot 10^6$ per second) of theta and zeta pinches. The pictures were taken with a rotating mirror through a narrow slit from the terminal surface of a cylindrical chamber in axial direction. As these experiments had been described earlier, the authors only discuss the results of this photographic method. A photographic camera of the type COP-2M (SFR-2M) was used. The experiments were made with hydrogen, helium, nitrogen, air

Card ~~1/6~~

84560

Instability of an Inductive (Theta) Pinch

S/057/60/030/011/003/009

B006/B054

argon, and krypton at different pressures. It was shown, among other things, that the effects observed depended greatly on the shape of the chamber cross section. The photographs taken are partly shown in Figs. 1 and 2, and the corresponding experimental conditions are given in Tables 1 and 2, respectively. In the following, the individual photographs and their conditions are described and discussed. The investigations showed that all plasma motions are very complicated, and that the instabilities of the pinches are of different forms. A relationship was found to exist between the character of plasma motion and the form of instability. In the pressure range from a few mm Hg up to 10^{-2} mm Hg, it was found that the intensity of eruptive instabilities increased with decreasing pressure, and at still higher pressures, such instabilities do no longer occur. $nkT > R^2/8\pi$ is a necessary condition for the occurrence of an eruption (nkT = thermal pressure of plasma). There are 2 figures, 2 tables, and 12 references: 3 Soviet, 1 German, 3, British, 2 US, and 3 Swiss.

SUBMITTED: May 30, 1960

~~Card 2/6~~

83610

S/056/60/038/005/043/050
B006/B063

26.2321

AUTHORS: Kvartskhava, I. F., Kervalidze, K. N., Gvaladze, Yu. S.

TITLE: Instability of an Induction Pinch

PERIODICAL: Zhurnal eksperimental'noy i teoreticheskoy fiziki, 1960,
Vol. 38, No. 5, pp. 1641 - 1643

TEXT: The present "Letter to the Editor" gives a fundamental representation of plasma motion in inductive (theta) pinches, and describes the experimental conditions under which the accompanying photographs were taken. At the Fourth International Conference on Ionization Processes in Gases, held at Upsala in 1959, the authors gave a report on the new kinds of instability of linear and inductive pinches, which had been observed during a compression shock in a plasma. These phenomena had been detected photographically. In the present paper, the authors report on further investigations carried out with a quick-acting camera of the type СФР-2М (SFR-2M). The effects of the instability of θ -pinches were recorded on a time magnifier basis. These effects are related to an azimuthal inhomogeneity of the velocities of the radial motion of the

Card 1/3

83610

Instability of an Induction Pinch

S/056/60/038/005/043/050
B006/B063

plasma during the compression shock. The various experimental conditions are given in a table. Glass or porcelain vessels served as discharge chambers, and air, nitrogen, and helium (pressures of 0.1 torr; one experimental series was performed with He at 0.07 torr) were used as discharge gases. The accompanying Fig. reproduces some of the photographs, the major part of which were taken in cylindrical discharge chambers. Those in the last two rows were taken in chambers with square cross sections. The exposure was 0.5 μ sec, and there was an interval of 2 μ sec between the various exposures. The photographs are described in detail along with the forms of the individual columns and the effect of the compression shock on them. All these effects vanish at higher gas pressure. Also in the case of smaller chamber diameters, they are largely reduced or absent. These phenomena are primarily due to the magnetohydrodynamic character of plasma motion in the magnetic field. For example, the azimuthal rotation of the expansion figures of the pinch in comparison to the compression figures is indicative of the significant role played for these processes by the reflection of shock waves at the magnetic fields captured by the plasma. The changes of the spatial figures are such as to remind one of the phenomena of an elastic

Card 2/3

9.3150,24.2120

77840
SOV/57-30-3-6/15

AUTHORS: Kvaratskhava, I. F., Meladze, R. D., Suladze, K. V.
TITLE: Investigations on Electrodynamic Acceleration of Plasma
PERIODICAL: Zhurnal tekhnicheskoy fiziki, 1960, Vol 30, Nr 3,
pp 289-296 (USSR)
ABSTRACT: The authors worked with two types of accelerators, the coaxial and the induction accelerator. In the first case, the plasma clot is built in a discharge between two coaxial electrodes and is accelerated by the magnetic field of the discharge current. In the second case, the clot is formed in an electrodeless gaseous discharge and accelerated by means of an inhomogeneous magnetic field quickly varying in time. These devices are shown on Fig. 1.

Card 1/9

Investigations on Electrodynamic Acceleration
of Plasma

77840
SOV/57-30-3-6/15

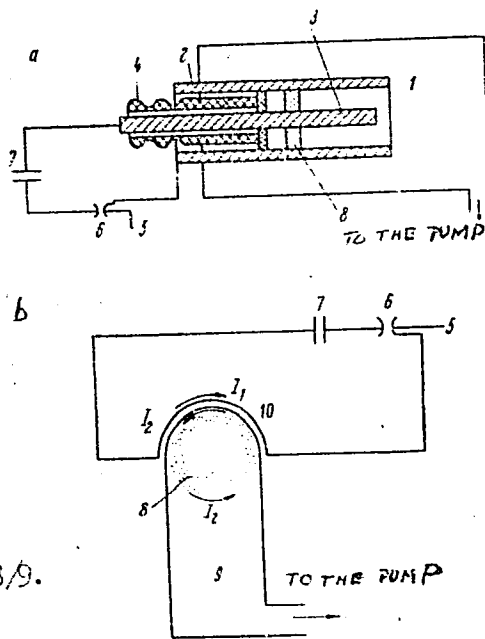

Fig. 1.
See caption on Card 3/9.

Card 2/9

Investigations on Electrodynamic Acceleration
of Plasma

77840
SOV/57-30-3-6/15

Caption to Fig. 1.

Fig. 1. (a) diagram of the coaxial accelerator;
(b) diagram of the induction accelerator. (1)
Vacuum chamber; (2) outer electrode; (3) inner
electrode; (4) porcelain insulator; (5) initiating
electrode; (6) discharge device; (7) battery of cap-
acitors; (8) plasma clot; (9) vacuum chamber; (10)
current-carrying bar.

The high-voltage capacitor battery had a total cap-
acitance of $10 \mu\text{F}$ and a working potential $U_0 = 50 \text{ Kv}$.

Current in the discharge interspace produces a drop
in magnetic field pressure and accelerates the plasma
clot along the electrodes. In the cylindrical quartz
chamber 9 of the induction accelerator, the current
in 10, due to the capacitor battery, produces a
magnetic field that increases in time, starting an
electrodeless discharge in the gas. The resultant

Card 3/9

Investigations on Electrodynamic Acceleration
of Plasma

77840
SOV/57-30-3-6/15

Forces of Ampere on the gaseous discharge are directed along the axes of the chamber and accelerate the plasma in the direction of the decreasing magnetic field. The discharge starts by means of an impulse on electrode α , synchronized with the photo-camera SFR-2M and the position of the spread-out mirror. Tests were performed at various pressures of hydrogen and air. The general impulse and the total kinetic energy of the clots, accelerated during one cycle of the capacitor discharge, were measured, respectively, by means of a ballistic pendulum made from a glass cylinder of a few hundred grams on bifilar suspension, and by means of a slanted copper cylinder with an opening through which entered the accelerated plasma. The volume of the cylinder was chosen so that the plasma remained inside long enough for the establishment of thermal equilibrium. Temperature difference was measured by means of sensitive thermocouples. The photo registration of the clots was performed in two ways, orienting the slit

Card 4/9

Investigations on Electrodynamic Acceleration
of Plasma

77840
SOV/57-30-3-6/15

of the apparatus parallel (longitudinal pictures) and perpendicular (transverse pictures) to the direction of propagation of the clots. The authors found that variations in the size of the coaxial device did not alter appreciably the observed processes. Analysing the longitudinal pictures, the authors found that after a leading strong plasma clot, starting during the first half period of the current, follow many small clots of lower density and higher velocities. The beginning velocities of the leading clot are inversely proportional to the initial pressure of the gas, while the final velocities are not too sensitive to the initial pressure. At lower initial pressures the leading clot was missing, and the authors deduced from the pictures that in the coaxial accelerator three kinds of clots are obtained: the leading clots, which carry almost all the gas out of the coaxial region, and two kinds of small clots originating at the beginning or at the end of the coaxial, depending on the ex-

Card 5/9

Investigations on Electrodynamic Acceleration
of Plasma

77840
SOV/57-30-3-6/15

perimental conditions. The latter case can be observed also under the Bostick plasma accelerator. The authors present also transverse photographs of the induction accelerator and longitudinal pictures of opposing motion and "collisions" of accelerated clots, emerging from coaxials facing one another. One sees that induction accelerator generates only one kind of clot, and they are most compact at low gas pressures. After leaving the strong magnetic field region, a clot generated during the later parts of the half periods of the current divides into two parts, one of which slows down appreciably, while the other continues without change in velocity. In this type of accelerator, clots are not capable of effectively removing the gas from the discharge region. In the coaxial device, the leading clot did not move faster than 10^7 m/sec, while the small clot attained velocities of $4 \cdot 10^7$ m/sec. Maximum current

Card 6/9

Investigations on Electrodynamic Acceleration
of Plasma

77840
SOV/57-30-3-6/15

amplitude during those tests was 80 ka, while a later increase to 300 ka led only to the increase in number of the small clots without increasing their velocity. Induction accelerator yielded velocities up to $6 \cdot 10^7$ m/sec. Total mass of the clots at $U_0 = 45$ kv was 10^{-4} gm for the coaxial device and of one order of magnitude lower for the induction accelerator. The authors conclude that the coaxial accelerator is more effective in obtaining fast fluxes of matter than the magnetic one. The authors obtain additional information by analysing the transverse pictures and those of the induction accelerator and opposing coaxial accelerators. To compare the experimental results for the clot velocity with theoretical expectations, the authors derive the average average velocity equation

$$\bar{v} = \frac{I_0}{t_0} = \frac{8\pi IU}{H^2 S}$$

Card 7/9

Investigations on Electrodynamic Acceleration
of Plasma

77840
SOV/57-30-3-6/15

where l_0 is distance traveled by the clot during the time t_0 , I discharge current, U positive accelerating potential, H average value of the accelerating field, and S cross-section surface of the coaxial. For optimal values of the parameters $I = 80$ ka, $U \approx 100$ v, $H \approx 20,000$ Oersted, and $S \approx 1.5$ cm², v comes out $3 \cdot 10^7$ cm/sec, which agrees satisfactorily with the measured values. The authors describe also the mechanism of formation of small-sized clots. Those obtained inside the coaxial are probably due to the fact that the electric strength lasts a finite time of 10^{-7} sec necessary to build up the strong current discharge against the counter emf due to the motion of the clot. Those originating at the outer end of the electrode are due to the fact that for some reason the main discharge current flows to the end of the electrode producing a flow of vapor which becomes pinched by the magnetic field of its own current. This pinching process is characterized by a definite

Card 8/9

Investigations on Electrodynamic Acceleration
of Plasma

77840

SOV/57-30-3-6/15

periodicity, and a series of small clots are obtained. An analogous mechanism operates under the Bostick accelerating conditions. There are 3 figures; and 9 references, 3 Soviet, 6 U.S. The five recent U.S. references are: W. Rayle. IRE Trans. Vol. Mil. 3, N^o2, 42-45, 1959. R. F. Post. Second United Nations International Conference on the Peaceful Uses of Atomic Energy, Geneva, Paper 15/P/377, 1958. L. Marschall. Second United Nations International Conference on the Peaceful Uses of Atomic Energy, Geneva, Paper, 15/P/355, 1958. A. C. Kolb. Phys. Rev., 107 N^o 2, 345-350, 1957. W. H. Bostick. Phys. Rev., 404, 1957.

ASSOCIATION: None given

SUBMITTED: October 24, 1959

Card 9/9

9.3150,24.2120

77011
SOV/97-30-3-7/15

AUTHORS: Kvartskhaya, I. F., Kervelidze, K. N., Gvaladze, Yu. S.

TITLE: Some Magneto-Hydrodynamic Effects Observed During the Pulse Compression of Plasma

PERIODICAL: Zhurnal tekhnicheskoy fiziki, 1980, Vol 30, Nr 3, pp 297-305 (USSR)

ABSTRACT: In connection with the problem of controlled thermonuclear reactions there is a growing interest in the properties of plasmas compressed by pulses in strong magnetic fields. As known, attempts to use linear and induction pinch for heating deuterium plasma up to thermonuclear temperatures were not successful, mainly because of significant reduction in ohmic heating of plasma at high ($> 10^{10}$ K) temperatures and presence of instabilities which lead to a worsening of magnetic thermal insulation of high temperature compressed plasma. The authors show the presence of instabilities consisting of ejections of plasma formations from

Card 1/9

Some Magneto-Hydrodynamic Effects Observed
During the Pulse Compression of Plasma

77841
SOV/57-30-3-7/15

induction and linear pinches representing apparently one of the forms of type $m > 1$ instabilities. They deduce from theoretical considerations and experimental evidence that it should be impossible to achieve thermonuclear temperatures by single pulse compression of plasmas. Also they investigated some other properties of induction pinch using the apparatus in Fig. 1. The battery of capacitors ($10-200 \mu f$) was connected by means of special leads reducing total induction of the system to a minimum of $0.01 \mu H$. Working potential was 50 kv; maximum rate of increase of current was 10^{12} a/sec. Firing system allowed a synchronization of discharge time to approximately 1μ sec. Continuous photoregistration was performed by photo-camera SFR-2M synchronized with discharge time, oscillograph sweep, and rotation of the spread-out mirror. Currents were measured by pulsed two-ray oscillograph OK-17 with a waiting sweep. Tests were performed

Card 2/9

Some Magneto-Hydrodynamic Effects Observed
During the Pulse Compression of Plasma

1984
301/47-30-3-1/15

in hydrogen at various pressures. Pictures were taken in the radial and axial direction with respect to the chamber axis, having the apparatus slit perpendicular or parallel to the chamber, respectively. In general, during discharge of condensers through the system of windings, a uniform axial magnetic field H appears in the chamber. This field varies with current variations and induces electrical fields which ignite the electrodeless discharge. Secondary currents circulate in planes perpendicular to the axis of the chamber. Whenever these currents are opposed to primary currents in the windings, the field inside the plasma decreases. The resulting drop in magnetic field pushes the plasma away from the walls of the chamber, squeezing it into the pinch. The equilibrium diameter of the pinch is determined by the equilibrium of pressures of the outside field, the magnetic field trapped inside the pinch, and the gas inside the pinch. Analyzing pictures for the case of hydrogen pressure $P_H = 0.5 \text{ mm Hg}$.

Card 3/9

$C = 40 \mu \text{ f}$, and $U_0 = 30 \text{ kv}$, the authors found that

Some Magneto-Hydrodynamic Effects Observed
During the Pulse Compression of Plasma

77841
SOV/67-30-3-7/16

during the final stage of the formation, the plasma oscillates radially around its equilibrium diameter. During the middle of the half-period the pinch diameter decreases with a simultaneous decrease in luminosity. Primary currents reach their maximum, secondary currents disappear, and the pinch cools down somewhat. During the second half of the half-periods the pinch again starts to shine because of reversed eddy currents, conserving the original diameter. Only after the end of the half-period when the external field vanishes, the plasma begins slowly to spread out. In these and similar pictures the authors did not observe any $m = 0$ or $m = 1$ instabilities, nor did they find them in the case of linear pinch. These findings are contrary to the theory that allows axial motion of plasma through the magnetic "envelope" of the pinch and would cause $m = 0$ or $m = 1$ instabilities. The authors conclude that existing theories do not take sufficiently into

Card 4/9

Some Magneto-Hydrodynamic Effects Observed
During the Pulse Compression of Plasma

77(34)
30V/57 30-3-7/15

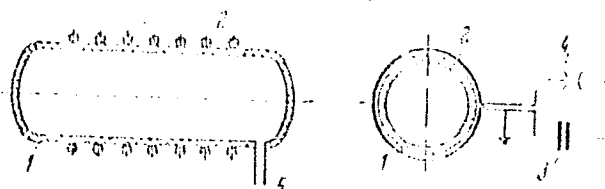

Fig. 1. (1) Discharge chamber; (2) windings;
(3) battery of capacitors; (4) triggering spark
discharge; (5) pumping tube.

Card 5/9

Some Magneto-Hydrodynamic Effects Observed
During the Pulse Compression of Plasma

77841
SOV/57-50-5-7/15

account the real processes occurring during the pinch formation. Analysis of pictures taken under changed conditions shows, among other things, that with $C = 13 \mu\text{f}$ and $U_0 = 40 \text{ kv}$ one can observe excitation shock waves reflected from the axis of the induction pinch which produce radial oscillations of the pinch and ejection of plasmoids. Apparently this represents one of the $m > 1$ type instabilities which the authors call eruptive instability. To achieve an ejection of the surface layers of the plasma one needs a magnetic field under that layer which could separate it from the rest of the plasma and compensate the outside field. This can occur at the expense of the kinetic energy of radial motion, and using appropriate probes registering dI/dt quantity the authors showed existence of such a strong inverse magnetic field. Any asymmetry in radial motion then could be responsible for asymmetry in ejection of the plasma. Using such asymmetries and conservation of momentum,

Card 6/9

Some Magneto-Hydrodynamic Effects Observed
During the Pulse Compression of Plasma

1971
SOV/91-30-3-1/15

the authors found mass of the plasmoids to be $3 \cdot 10^{-6}$ - $4 \cdot 10^{-7}$ gm, which constitutes a few percent of its total mass. Although this could not produce any appreciable consumption of energy, it leads to a worsening of thermal insulation of the pinch which could represent an effect of fundamental importance. The authors note that the eruptive instabilities of pinches could be suppressed by choosing appropriate field configurations; e.g., a field increasing with increase of its radius R. Finally, the authors note that the heating of the plasma occurs at the expense of the kinetic energy of its electrodynamic compression, and the aim of experiments is, therefore, to achieve a high velocity of compression. Starting from field energy equations, the authors develop an equation for the average velocity of plasma motion

$$v = \frac{8kH_0}{H^2(R+r_0)}$$

Card 7/9

Some Magneto-Hydrodynamic Effects Observed
During the Pulse Compression of Plasma

77841
SOV/57-30-3-7/15

where I is primary current, U_0 is initial emf, k is a proportionality constant, and H_0 is outside magnetic field. Experiments showed that the experimental maximum compression velocity agrees with the order of magnitude of computed value for \bar{V} . Discussing the equation

the authors note that the optimum compression velocity of plasma depends very little on power of impulse IU_0 .

It is therefore impossible to achieve in the induction pinch compression velocities higher than 10^7 cm/sec. Experiments show the same is true for other methods of pulse compression of plasma. After investigating the mechanism of the process which leads to the situation where the acceleration is achieved in a relatively short lapse of time while the rest of the period the source of energy idles, the authors conclude that one cannot achieve thermonuclear temperatures by a single pulse compression of the pinch. One apparently needs a process during which plasma will be subjected to multiple expansion and then intensive compression.

Card 8/9

Some Magneto-Hydrodynamic Effects Observed
During the Pulse Compression of Plasma

73841
SOV/57-30-3-1/15

At the same time one would need very strong magnetic fields to suppress eruptive instabilities of the pinch. There are 4 figures; and 24 references, 13 Soviet, 6 U.K., 5 U.S. The most recent U.K. and U.S. references are: J. L. Craston, et al., Second Geneva Conference on the Peaceful Uses of Atomic Energy, Paper 15, 34, 1958; S. A. Colgate, H. P. Furth, Science, 128, Nr 3320, 337 (1958); O. A. Anderson, W. R. Baker, S. A. Colgate, J. Ise, Jr., R. V. Pyle, Proc. 3-rd Intern. Conf. on Ionization Phenomena in Gases, Venice, 1957; L. C. Burkhardt, et al., J. Appl. Phys., 26, 519 (1957); B. H. Bostick, Phys. Rev., 106, 404 (1957).

SUBMITTED: October 24, 1959

Card 9/9

L 28476-66 EPF(n)-2/EWT(1)/EWT(m)/ETC(f)/EWG(m)/T IJP(c) AT/DS
ACC NR: AP6013135 SOURCE CODE: UR/0057/66/036/004/0755/0759

AUTHOR: Kvartskhava, I.F.; Matveyev, Yu.V.; Moladze, R.D.; Khautiyev, E.Yu.

59
B

ORG: none

TITLE: On possible reasons for the influence of electrode polarity on acceleration of plasma in a rail accelerator

SOURCE: Zhurnal tekhnicheskoy fiziki, v. 36, no. 4, 1966, 755-759

TOPIC TAGS: plasma accelerator, plasma acceleration, rail accelerator, cathode spot, arc discharge, plasma pinch

ABSTRACT: It is known that the anode end of the current sheet in a rail accelerator moves with greater acceleration than does the cathode end. It is argued that this phenomenon is due to behavior of the plasma associated with the formation of electrode spots. Examination of used electrodes has shown that both cathode and anode spots occur in rail accelerators, and that the traces of the cathode spots are deeper and less continuous than those of the anode spots. It is argued that under conditions in which the plasma electrons are magnetized the concentration of current in the vicinity of a cathode spot leads to explosive ejection of a jet of plasma from the region of the electrode. The ion motions in such a jet issuing from the cathode arc in the direction opposite to that of the discharge current in the sheet, and the Lorentz force on these moving ions thus tends to retard the motion of the cathode end of the

UDC: 533.9

Card 1/2

L 28476-66

ACC NR: AP6013135

0
accelerating plasmoid. Jets issuing from the anode, on the other hand, are not only less intense, but the ions in them move in the direction of the current and thus tend to enhance the acceleration of the anode end of the plasmoid. The discussed mechanism is also relevant to the motion of cathode spots in an arc discharge and is apparently associated with the end effects in a linear pinched discharge noted by A. Folkierski, P.G. Frayne, and R. Latham (Rept. No. CN-10/48A, Salzburg, 1961). Orig. art. has: 2 figures.

SUB CODE: 20

SUBM DATE: 22Oct65

ORIG. REF: 005

OTH REF: 008

Card 2/2 CC

KVARTSKHAVA, P., kand. biolog. nauk (Kobuleti, Gruzinskoy SSR)

Pomegranate scab. Zashch. rast. ot vred. i bol. 10 no.7:54 '65.
(MIRA 18:10)

KVARTSKHAVA, P. A.

Kvartskhava, P. A.: "Tung bacteriosis caused by Bacterium ci triputeale",
Byulleten' Vsesoyuz. nauch.-issled. in-ta chaya i subtrop, kul'tur,
1948, No. 4, p. 159-64.

SO: U-3042, 11 March 53, (Letopis 'nykh Statey, No. 10, 1949).

KVARTSKHAYA, P. A.

COUNTRY : USSR
CATEGORY : Plant Diseases. Diseases of Cultivated Plants 0

ABS. JOUR. : RZhBiol., No. 23 1958, No. 105046

AUTHOR : Kvartskhaya, P. A.
INST. : Sukhum Zonal Experiment Station of Etheral Oil Plants.
TITLE : On the Study of Infectious wilt (Fusariosis) of Eugenol Basil (*Ocimum gratissimum*).

ORIG. PUB. : Tr. Sukhumsk. zonal'n. opyt. st. efiromaslich. kul'tur., 1957, vyp. 2, 101-113

ABSTRACT : The disease causes serious damage on plantations and nurseries in Abkhazia. The typical symptoms of fusariosis are: a lengthwise streak on the stem, underdeveloped and chlorotic leaves, their wilting and dropping-off, the bending of the affected part of the stem. The pathogen (*Fusarium* sp.) penetrates chiefly through the root system. Injuries to the root tissue and the stem base caused from tools, insects and other causes, contribute to the infection. A source of infection is the residue of the

CARD: 1/2

COUNTRY :

CATEGORY :

ABS. JOUR. : RZhBiol., No. 1958, No. 105046

AUTHOR :

INST. :

TITLE :

ORIG. PUB. :

ABSTRACT :

sick plants from which the fungus getting into soil develops there on the dead residues of various plants, including weeds. The affected seedlings, and also to some extent the seeds from the diseased plants, are the principle sources of the dissemination of the disease on new plots. Measures for the control are indicated. The pathogen is a specialized parasite of *Ocimum gratissimum*, and does not infect other plants, among them geraniums and patchouli, in the breeding place of the disease. -- G. A. E'yakova

CARD-2/2

KVARTSOV, Konstantin Ivanovich; LINITSKIY, Viktor Georgiyevich;
LYUBIMOV, N.G., otv.red.; SABITOV, A., tekhn.red.

[KSP-1 mobile scraper conveyer] Skrebkovyi peredvizhnoi
konveier KSP-1. Moskva, Ugletekhizdat, 1959. 63 p.

(MIRA 12:5)

(Conveying machinery) (Coal-handling machinery)

LINITSKIY, Viktor Georgiyevich; KVARTSOV, Konstantin Ivanovich; KOLOMIYTSSEV,
A.D., otv.red.; IL'INSKAYA, G.M., tekhn.red.

[The KSTI-20 scraper conveyer] Skrebkovyi konveier KSTI-20.
Moskva, Gos.nauchno-tekhn.isd-vo lit-ry po gornomu delu, 1960.
58 p. (MIRA 13:7)

(Scrapers) (Conveying machinery)

HERVET, Vl., inz.; KVESEK, Mil., inz.; KVAS, Jul., inz.; SVOBCDA, Fr., inz.;
VIZEK, K., inz.

Pile foundation of the steel structure of halls of a machine
metallurgy plant in India. Inz stavby 13 no.3:98-107 Mr '65.

ACC NR:AP7008531

SOURCE CODE: UR/0363/67/003/002/0395/0397

AUTHOR: Paderno, Yu. B.; Yupko, V. L.; Rud', B. M.; Kvas, O. F.;
Makarenko, G. N.

ORG: Institute of Material Science Problems, AN UkrSSR (Institute
problem materialovedeniye AN UkrSSR)

TITLE: Electrophysical properties of Gd, Tb, Dy, Er, Tu dicarbides

SOURCE: AN SSSR. Izvestiya. Neorganicheskiye materialy, v. 3, no. 2,
1967, 395-397

TOPIC TAGS: gadolinium ~~dicarbide~~, terbium ~~dicarbide~~, dysprosium
~~dicarbide~~, erbium ~~dicarbide~~, thulium ~~dicarbide~~, dicarbide ~~dicarbide~~,
carbide, resistivity, Hall effect, carrier density

ABSTRACT: The results are presented of an experimental determination
of the electrophysical properties of Gd, Tb, Dy, Er, and Tu dicarbides.
Initial powder carbides were obtained by the reduction of metal oxides
with carbon in vacuum at 1800°C for 25-60 min. The carbide powders were
compacted and sintered in argon at 1700-1800°C for 15 min under a
pressure of 100 kg/cm²; the porosity of sintered compacts was 5-13%;
finished specimens were annealed at 1650°C for 8 hr. It was found that
carbide resistivity changed from 30 μohm.c. for GdC₂ to 515 μohm.cm for

Card 1/2

UDC: 546.65'261:541.12.03

ACC NR: AP7008531

TuC₂; the coefficient of emf from -5.95 $\mu\text{v}/^\circ\text{C}$ for ErC₂ to -7.75 $\mu\text{v}/^\circ\text{C}$ for TbC₂; Hall effect from -2.55 cm^3/coul for TbC₂ to +136 cm^3/coul for TuC₂; effective carrier concentration from 0.018 $\text{el}/\text{atom M}$ for TuC₂ to 1.04 $\text{el}/\text{atom M}$ for TbC₂; and mobility from 6.75 $\text{cm}^2/\text{v. sec}$ for ErC₂ to 19.6 $\text{cm}^2/\text{v. sec}$ for TuC₂. Melting points ranged from 2180 $^\circ\text{C}$ for TuC₂ to 2280 $^\circ\text{C}$ for ErC₂. Orig. art. has: 1 figure and 2 tables. [TD]

SUB CODE: 11/ SUBM DATE: 13Jan66/ ORIG REF: 009/ OTH REF: 008

Card 2/2