

PROCESSES AND PROPERTIES INDEX

Synthesis of high-strength dental silicate cement.
P. P. BUDNIKOV AND I. G. GOL'DENBERG. *Zhur. Priklad. Khim.*, 17 [7-8] 417-21 (1944). The basis for the dental cement was the charge containing calcined Al_2O_3 24.2, quartz sand 33.3, synthetic cryolite 36.0, and CaH_2PO_4 7.5%. The charge was ground to pass a sieve of 10,000 openings/cm² and calcined at 1350°. The melted and granulated mass was mixed with a special liquid made by dissolving 8 parts of $Al(OH)_3$ and 9 parts of ZnO in 83 parts of boiling H_3PO_4 . The cement has good adhesion, hardens completely in 15 to 20 min., and can be polished to give a lustrous surface; the luster, density, and translucence are not impaired after a 2 week immersion in saliva at 37°C. The cement compares favorably with the De Trey (Suisse) silicate cement. B. Z. K.

ASAC 1-1975
ASAC 2-1975
ASAC 3-1975
ASAC 4-1975
ASAC 5-1975
ASAC 6-1975
ASAC 7-1975
ASAC 8-1975
ASAC 9-1975
ASAC 10-1975
ASAC 11-1975
ASAC 12-1975
ASAC 13-1975
ASAC 14-1975
ASAC 15-1975
ASAC 16-1975
ASAC 17-1975
ASAC 18-1975
ASAC 19-1975
ASAC 20-1975
ASAC 21-1975
ASAC 22-1975
ASAC 23-1975
ASAC 24-1975
ASAC 25-1975
ASAC 26-1975
ASAC 27-1975
ASAC 28-1975
ASAC 29-1975
ASAC 30-1975
ASAC 31-1975
ASAC 32-1975
ASAC 33-1975
ASAC 34-1975
ASAC 35-1975
ASAC 36-1975
ASAC 37-1975
ASAC 38-1975
ASAC 39-1975
ASAC 40-1975
ASAC 41-1975
ASAC 42-1975
ASAC 43-1975
ASAC 44-1975
ASAC 45-1975
ASAC 46-1975
ASAC 47-1975
ASAC 48-1975
ASAC 49-1975
ASAC 50-1975
ASAC 51-1975
ASAC 52-1975
ASAC 53-1975
ASAC 54-1975
ASAC 55-1975
ASAC 56-1975
ASAC 57-1975
ASAC 58-1975
ASAC 59-1975
ASAC 60-1975
ASAC 61-1975
ASAC 62-1975
ASAC 63-1975
ASAC 64-1975
ASAC 65-1975
ASAC 66-1975
ASAC 67-1975
ASAC 68-1975
ASAC 69-1975
ASAC 70-1975
ASAC 71-1975
ASAC 72-1975
ASAC 73-1975
ASAC 74-1975
ASAC 75-1975
ASAC 76-1975
ASAC 77-1975
ASAC 78-1975
ASAC 79-1975
ASAC 80-1975
ASAC 81-1975
ASAC 82-1975
ASAC 83-1975
ASAC 84-1975
ASAC 85-1975
ASAC 86-1975
ASAC 87-1975
ASAC 88-1975
ASAC 89-1975
ASAC 90-1975
ASAC 91-1975
ASAC 92-1975
ASAC 93-1975
ASAC 94-1975
ASAC 95-1975
ASAC 96-1975
ASAC 97-1975
ASAC 98-1975
ASAC 99-1975
ASAC 100-1975

1ST AND 2ND ORDERS PROCESSES AND PROPERTIES INDEX

CA

19

Acidproof enamels on iron from available materials.
P. P. Budrikov and I. G. Goldenberg. *Khimicheskaya Prom.* 1945, No. 12, 14-15. Of a no. of enamels tested the 2 that proved most satisfactory were: quartz sand 53.2, 57.0; feldspar 11.8, 13.8; calcined soda 21.0, 16.8; potash 3.0, 3.1; CaCO₃ 11.0, 10.0; ZnO 0.0, 2.0%; resp. The chem. compn. was: SiO₂ 60.82, 70.20; Al₂O₃ 2.25, 2.10; Na₂O 0.54, 10.75; K₂O 3.04, 3.72; CaO 17.00, 10.95; ZnO 0.0 and 2.19%; resp. The 2nd enamel (contg. ZnO) is not suitable for app. in which foods are treated. The m.p. of these enamels is 890-900°. They form colorless glasses adhering well to iron. Their resistance to boiling 20% HCl, 20% H₂SO₄, 20% HNO₃, 10% citric acid, and 10% AcOH was satisfactory. Thermal resistance was tested by heating enameled test pieces to 212° and then plunging them into tap water. The enamels withstood 15 changes (5 is the required no.). The mech. properties of the enamels were good.

M. Hosen

ASB-SLA METALLURGICAL LITERATURE CLASSIFICATION

1	2	3	4	5	6	7	8	9	10	11	12	13	14	15	16	17	18	19	20	21	22	23	24	25	26	27	28	29	30	31	32	33	34	35	36	37	38	39	40	41	42	43	44	45	46	47	48	49	50	51	52	53	54	55	56	57	58	59	60	61	62	63	64	65	66	67	68	69	70	71	72	73	74	75	76	77	78	79	80	81	82	83	84	85	86	87	88	89	90	91	92	93	94	95	96	97	98	99	100
---	---	---	---	---	---	---	---	---	----	----	----	----	----	----	----	----	----	----	----	----	----	----	----	----	----	----	----	----	----	----	----	----	----	----	----	----	----	----	----	----	----	----	----	----	----	----	----	----	----	----	----	----	----	----	----	----	----	----	----	----	----	----	----	----	----	----	----	----	----	----	----	----	----	----	----	----	----	----	----	----	----	----	----	----	----	----	----	----	----	----	----	----	----	----	----	----	----	----	-----

PROCESSES AND PROPERTIES IN THE

Role of calcium sulfoaluminate in the exothermal hardening of alumina cement. P. P. BUDNIKOV AND I. G. GOL'DENBERG. *Zhur Priklad. Khim.*, 14 (1-2) 15-19 (1945). Exothermal curves were obtained of ordinary alumina cement made from blast furnace alumina slag and of the same cement with additions of anhydrite. Experiments were conducted at 15°C under conditions of natural liberation of heat and at 65° to 70° and higher analogous to conditions existing in large concrete blocks. The results show that, for cement hardening at high temperatures, the anhydrite binds the $3CaO \cdot Al_2O_3 \cdot 6H_2O$ into useful products. The mechanical properties of the hardened cement are also improved. B. Z. K.

AS A SLA METALLURGICAL LITERATURE CLASSIFICATION

1	2	3	4	5	6	7	8	9	10	11	12	13	14	15	16	17	18	19	20	21	22	23	24	25	26	27	28	29	30	31	32	33	34	35	36	37	38	39	40	41	42	43	44	45	46	47	48	49	50	51	52	53	54	55	56	57	58	59	60	61	62	63	64	65	66	67	68	69	70	71	72	73	74	75	76	77	78	79	80	81	82	83	84	85	86	87	88	89	90	91	92	93	94	95	96	97	98	99	100
---	---	---	---	---	---	---	---	---	----	----	----	----	----	----	----	----	----	----	----	----	----	----	----	----	----	----	----	----	----	----	----	----	----	----	----	----	----	----	----	----	----	----	----	----	----	----	----	----	----	----	----	----	----	----	----	----	----	----	----	----	----	----	----	----	----	----	----	----	----	----	----	----	----	----	----	----	----	----	----	----	----	----	----	----	----	----	----	----	----	----	----	----	----	----	----	----	----	----	-----

CA

20

Behavior of sulfated alumina cement toward attack
 P. P. Budnikov and I. G. Gol'denberg. *Zhur. Priklad. Khim.* (J. Applied Chem.) 20, 1165-9(1947) (in Russian)
 —A decrease in the exothermic nature of Ca aluminate hardening and improved concrete strength results from the introduction of CaSO_4 into alumina cements in the form of anhydrite. Such a cement may have the following compo: SiO_2 4.04, Al_2O_3 40.42, Fe_2O_3 2.50, CaO 29.16, MgO 0.32, and SO_3 13.46%. It exhibits corrosion resistance equal to that for conventional alumina cement shows equal bonding strength with steel at 18-20, and two-fold increased bonding strength with steel at 60-85.
 Marshall Sittig

ASB-31A METALLURGICAL LITERATURE CLASSIFICATION

1	2	3	4	5	6	7	8	9	10	11	12	13	14	15	16	17	18	19	20	21	22	23	24	25	26	27	28	29	30	31	32	33	34	35	36	37	38	39	40	41	42	43	44	45	46	47	48	49	50	51	52	53	54	55	56	57	58	59	60	61	62	63	64	65	66	67	68	69	70	71	72	73	74	75	76	77	78	79	80	81	82	83	84	85	86	87	88	89	90	91	92	93	94	95	96	97	98	99	100
---	---	---	---	---	---	---	---	---	----	----	----	----	----	----	----	----	----	----	----	----	----	----	----	----	----	----	----	----	----	----	----	----	----	----	----	----	----	----	----	----	----	----	----	----	----	----	----	----	----	----	----	----	----	----	----	----	----	----	----	----	----	----	----	----	----	----	----	----	----	----	----	----	----	----	----	----	----	----	----	----	----	----	----	----	----	----	----	----	----	----	----	----	----	----	----	----	----	----	-----

Thursday, September 26, 2002
APPROVED FOR RELEASE: Thursday, September 26, 2002

CIA-RDP86-00513R000515620010-1
CIA-RDP86-00513R000515620010-1"

R

i

CONFIDENTIAL

GOL'DENBERG, I.I., inzh., ISAKOVSKIY, I.G., ekonomist; BEREZIN, B.F.,
inzh.; STOTIK, V.S., inzh., VOROB'YEVA, L.V., tekhn.red.

[Economic efficiency of capital investments and new machinery in
transportation construction] Ekonomicheskaya effektivnost'
kapital'nykh vlozhenii i novoi tekhniki v transportnom
stroitel'stve. Moskva. Vses. izdatel'sko-poligr. ob"edinenie
M-sva putei soobshcheniia, 1962. 235 p. (Bubushkin, Vsesoiuznyi
nauchno-issledovatel'skii institut transportnogo stroitel'stva.
Trudy, no.43). (MIRA 16:2)
(Transportation--Buildings and structures)

(S) [Illegible]

[Illegible]

[Illegible]

VAYNSHTEYN, B.S., kand. ekon. nauk; LEYKINA, K.B.; MIMS, H.G.;
LUCHINSKIY, S.M.; KIYEVSKIY, V.G., kand. ekon. nauk;
VINER, S.A.; BINIAURISHVILI, I.I.; GUREVICH, M.S.;
ZIKYEV, B.V., kand. tekhn. nauk; RUBINOV, N.B.;
SARYCHEV, V.S., kand. tekhn. nauk; APARIN, I.L.;
KRINITSKAYA, M.Ye.; DEIKOVSKIY, G.I.; ZEL'TSER, R.Ye.;
GOL'DENBERG, I.L.; ISAKOVSKIY, I.G.; DEMIDOVA, S.H.,
inzh., red.

[Economic efficiency of capital investments and the
introduction of new equipment in construction] Ekonomiche-
skaia effektivnost' kapital'nykh vlozhenii i vnedreniia
novoi tekhniki v stroitel'stve. Moskva, Stroizdat, 1965.
235 p. (MIRA 18:6)

1. Moscow. Nauchno-issledovatel'skiy institut ekonomiki
stroitel'stva. 2. Rukovoditel' sektora ekonomicheskoy
effektivnosti novoy tekhniki Nauchno-issledovatel'skogo
instituta ekonomiki stroitel'stva, Moskva (for Kiyevskiy).
3. Sektor ekonomicheskoy effektivnosti novoy tekhniki
Nauchno-issledovatel'skogo instituta ekonomiki stroitel'-
stva, Moskva (for all ~~except~~ Demidova). 4. Nauchno-issledo-
vatel'skiy institut ekonomiki stroitel'stva, Moskva (for
Demidova).

GOL'DENBERG, I.S., inzh.

Remodeling pipe-laying machines to be used in assembling tanks
with solid coverings. Nov.tekh.mont.1 spets.rab.v stroi. 21
no.7:21 J1 '59. (MIRA 12:10)

1. Stroitel'nyy uchastok No.73 tresta No.7 Glavneftesontazha
Minstroya RSFSR.
(Tanks) (Cranes, Derricks, Etc.)

BRZHOZOVSKIY, V.F., inzh., red.; ISAYEV, N.V., inzh., red.; GOL'DENBERG, I.S., inzh., red.; PEVZNER, A.S., red. izd-va; CHERKASSKAYA, F.T., tekhn. red.

[Construction specifications and regulations] Stroitel'nye normy i pravila. Moskva, Gosstroizdat. Pt.3. Sec.G. ch.9.[Process piping; regulations for manufacture and acceptance of work (SNiP III-G.9-62)] Tekhnologicheskie truboprovody; pravila proizvodstva i priemki rabot (SNiP III-G. 9-62). 1963. 24 p.

(MIRA 16:6)

1. Russia (1923- U.S.S.R.) Gosudarstvennyy komitet po delam stroitel'stva. 2. Gosstroy SSSR (for Brzhozovskiy). 3. Mezhdumostvennaya komissiya po peresmotru stroitel'nykh norm i pravil (for Isayev). 4. Proyektno-konstruktorskaya kontora Proyektnefte-spetsmontazh Ministerstva stroitel'stva RSFSR (for Gol'denberg).
(Pipe) (Petroleum refineries--Equipment and supplies)

GOL'DENBERG, I.S.

Fluorescence method of examination in dermatology. Vest. dermat.
i ven. 37 no.2:54-56 F'63. (MIRA 16:10)

1. Iz kafedry koznykh i venericheskikh bolezney Kuybyshevskogo
meditsinskogo instituta (na. - prof. A.S.Zenin).

*

GOL'DENBERG, I. S.

C reactive protein test as an indication of the state of the
organism in some skin diseases. Vest. dermat. i ven. 38 no.4:27-
31. Apr '64. (MIRA 18:4)

Dr. Gol'denberk I. S. venereologicheskaya bolezniy Kyrgyzskogo
meditsinskogo instituta.

GOLDENBERG, I.V., inzh.

Development of suburban transportation. Gor. khaz. Mosk. 35 no.3:14-17
Mr '61. (MIRA 14:5)

(Moscow region--Transportation)

IVANOVA, M.G.; GOL'DENBERG, I.Ya.; LUKASHEV, I.I.; KARUT, T.A.; KANDYBA, S.G.;
MIKHAYLICHENKO, P.M.; NAKHMANSON, G.L.

Studies on biological properties of *Mycobacterium tuberculosis* var. *hirs.*
Probl. tuberk., Moskva no. 3:22-28 May-June 1952. (ZIML 22:4)

1. Of the Ukrainian Tuberculosis Institute (Director -- Prof. B. M.
Khmel'nitskiy), Khar'kov.

LUKASHOV, I.I., professor.; GOL'DENBERG, I.Ya., professor, [deceased].; IVANOVA,
M.I., dotsent.; KARUT, T.A., dotsent.; MIKHAILICHENKO, P.M., vrach.;
KANDYBA, S.G., vrach.

Studying sheep and swine for the pathogenic properties of a culture
grown from tuberculosis bacilli isolated from field voles. Sbor. trud.
Khar'. vet. inst. 22:248-251 '54. (MLRA 9:12)

1. Kafedra epizootologii Khar'kovskogo veterinarnogo instituta i
tuberkuleznyy otdel Khar'kovskogo instituta epidemiologii i mikrobiologii
imeni I. I. Mechnikova.
(Tuberculosis in animals)

GOL'DENBERG, I.Z., inzh.; SEMENOV, L.M., inzh.

Using a grouping technique in the assembly and welding plant.
Sudostroenie 27 no.2:48-50 F '61. (MIRA 16:7)

(Shipfitting)

GOL'DENBERG, I.

More on the business type accounting in meat combines. Mian.
ind. SSSR 26 no.3:42-43 '55. (MLFA 8:9)

1. Kiyevskiy mezhoblastnoy myasotrest
(Meat industry--Accounting)

GOL'DENBERG, L.

~~_____~~
Economizing meat. Mias. ind. SSSR 27 no.5:46-47 '56. (MLRA 9:11)

1. Ukrglavmyaso.
(Sausages--Transportation)

GOL'DENBERG, L.

Developing and introducing dispatcher control systems of the course
of production. Biul. nauch. inform.: trud i zar. plata no. 4: 159-160
'59. (MIRA 12:6)
(Production control) (Electronic control)

GOL'DENBERG, L.

Accounting in beef cattle transportation. *Mias.ind,S.S.S.R.* 33
no.6:42 '62. (MIRA 16:1)

1. Ukgipromyasomolprom.
(Meat industry--Costs)
(Beef cattle--Transportation)

305

10/20/50-10-1-10/50

TO: Moscow, U.S.S.R.

FROM: New Facts on the 1917-1918 Campaign in the Caucasus, by F. F. Berg, 1921-22

RE: Campaign in the Caucasus, 1917-1918, by F. F. Berg, 1921-22

NOTE: This is a historical account of operations in the area of the Caucasus during the campaign of Colonel F. F. Berg of the General Staff, in 1917-18, during which valuable data on military operations and other details were obtained. These data are of great interest and importance, 17 of which are detailed in the report.

CLASSIFICATION: This is a historical account of operations in the area of the Caucasus during the campaign of AN SSSR (Multi-purpose Security and Information)

305/1

NOVOMBERGSKIY, N.Ya.; GOL'DENBERG, L.A.; TIKHONIROV, V.V.

Data on the history of mineral prospecting in the Russian State of
the 17th century from the documents of the Siberian Command. Con. to
ist. geol. znani. no.8:3-6) '59. (MIRA 13:3)
(Prospecting)

GOL'DENBERG, L.A.

Maps of the Northern Caucasus made in 1768 and 1772 and S.L.
Voniavin's manuscript "My studies in mineralogy, 1768". Ozh. r.
ist. geol. znan. no.8:127-148 '59. (MIRA 13:3)
(Geology)

GOL'DENBERG, L.A., kand.istor.nauk

Unpublished drawings by V.I.Roborvskii. Priroda 49 no.10:102-104
O '60. (MIRA 13:10)

1. Kompleksnaya yuzhnaya geologicheskaya ekspeditsiya AN SSSR.
(Roborvskii, Vsevolod Ivanovich, 1856-1910)

COL' LENING, L.A.; MOSOV, S.P.

From the history of the first scientific expeditions after
the establishment of Soviet power. Trudy Inst. ist. est. i tekhn.
37:311-329 '61. (LINA 14:18)
(Lens Valley---Hydrography)

YEFIMOV, A.V.; GOLDBERG, L.A., kant.1202,naik

Essays from the history of Russian geographical research for
1735-1740 by V.I. Grekov. Reviewed by A.V. Efimov, L.A. Gol'denberg.
Vest. AN SSSR 32 no. 3:122-126 F. 1962. (IBRA 1962)

1. (Chief Correspondent AN SSSR for Yefimov),
(Bibliography - Science)

YAFENIN, A.L., akademik, otv. red.; GOL'DENBERG, L.A., kand. ist. nauk, otv. red.; SHALINA, L.I., red. izd-va; SROKNET, B.S., red. izd-va; NOVIKOV, N.D., tekhn. red.; KASHINA, P.S., tekhn. red.

[First Russian scientific studies of the Uturt] Pervye russkie nauchnye issledovaniia Uturta. Moskva, Izd-vo AN SSSR, 1963. 325 p. (MIRA 16:11)

J. Akademiya nauk SSSR. Otdeleniye biologo-geograficheskikh nauk SSSR.

(Uturt--Russian exploration)

GOL'DENBERG, L.A., kand. istoricheskikh nauk; KLEYNER, Yu.M. (Moskva)

In a century and a half; changes in the coastlines of the
Caspian and Aral Seas. Priroda 52 no.11:97-99 '63.
(MIRA 17:1)

GOLITSIN, A. A.

The first atlas of "maps" delineations of Siberia. Izv Vses
geog ob-va 96 no. 1.39-45 Jan 1964. (MERA 17:5)

СЕМЕНОВ, Семён Филиппович; СЕМЕНОВ, А.В., стл. ред.

[Semën U. Filanov, a Semenov, Siberian cartographer and
geographer (1842-1912)] Семён Филиппович Семенов,
сибирский картограф и географ (1842-1912 гг.) Москва,
Наука, 1978. 178 с. (СИБИР 18.8)

1. Given correspondent AM 1008 (for Yelimov).

"Meßgeräte und Vorrichtungen zur nichtinvasiven Messung der Betriebsparameter
in der Maschinen- und Abbaumechanischen Industrie"

report presented at the
Int'l. Measurements Conference (IMX) Budapest, 29-30 November 1984

GOL'DENBERG, Leonid Davydovich; YEMEL'YANOVA, Ye.V., red.; SKVIRSKAYA, R.I.,
tekh. red.

[Central control of the operation of equipment in machinery
manufacture] Dispetcherskii kontrol' ispol'zovaniia oborudovaniia
v mashinostroenii. [Leningrad] Lenizdat, 1958. 126 p. (MIRA 11:9)
(Machinery--Construction)

2

Conveyer system of window-glass manufacture. L. G. GOL'DENBERG. *Steklo* 1949, 1046, No. 11, pp. 3-4. Details are given on the progress made in Russian window-glass plants in adopting the conveyer system of production. B.Z.K.

APPROVED FOR RELEASE: Thursday, September 2, 1993
APPROVED FOR RELEASE: Thursday, September 2, 1993

RU005156200101
153000115200101

PROCESSES AND PROCEDURES INDEX

C

Drying of sulfate in suspended condition. I. G. Goulet-Sukro. *Sokolnaya Akad. Pr.* 1947, No. 4, pp. 3-6. A new method of drying sulfate in the suspended condition has been tested at the Selenga sulfate plant with promising results. The mirabilite is charged by load into a mixer to which water, heated by steam to 50-60°C, is added. The density of the solution in the mixer is adjusted at 1.3, after which the contents are transferred into a settling tank. After settling, the solution is pumped into a distribution tank from where it flows by gravity through a steam-heated pipe into another distribution tank. From this tank the solution is pumped to sprayers fixed into the walls of a vertical furnace. The solution reaches the sprayers under pressure of 2 atm. The sulfate is dried by the furnace gases from the fuel coal. To obtain a completely dry product, the furnace temperature must be maintained at 360-380°. Consumption of fuel was 140 kg of coal per ton of dry sulfate, loss of sulfate was 6.7%. Efficiency of the installation was about 35%. The efficiency can be raised by using more sprayers and improving the design of the furnace. At present, the dry product is removed through doors near the bottom of the furnace. This disturbs the draft in the furnace, in addition, 2 hr are required to remove the dry sulfate that accumulates during an 8-hr. shift of operations. B.Z.K.

ASB-SLA METALLURGICAL LITERATURE CLASSIFICATION

127 1 11

1	2	3	4	5	6	7	8	9	10	11	12	13	14	15	16	17	18	19	20	21	22	23	24	25	26	27	28	29	30	31	32	33	34	35	36	37	38	39	40	41	42	43	44	45	46	47	48	49	50	51	52	53	54	55	56	57	58	59	60	61	62	63	64	65	66	67	68	69	70	71	72	73	74	75	76	77	78	79	80	81	82	83	84	85	86	87	88	89	90	91	92	93	94	95	96	97	98	99	100
---	---	---	---	---	---	---	---	---	----	----	----	----	----	----	----	----	----	----	----	----	----	----	----	----	----	----	----	----	----	----	----	----	----	----	----	----	----	----	----	----	----	----	----	----	----	----	----	----	----	----	----	----	----	----	----	----	----	----	----	----	----	----	----	----	----	----	----	----	----	----	----	----	----	----	----	----	----	----	----	----	----	----	----	----	----	----	----	----	----	----	----	----	----	----	----	----	----	----	-----

FOI(b) (7) - (C)

SECRET [Faint, mostly illegible text]

[Faint, mostly illegible text]

Re abo.

*SS. Ceramics,
Refractories*

Thin layer batch-charging; charging of briquettes in glass furnace.
I. G. Goldenberg (*Stal Krasn.*, 1948, 8, No 3, 18. *Dokl. Akad. Nauk SSSR*, 1949, 12A).

R. H. CLARKE

C

Use of Aral [Sea] sulfate in glassmelting. I. G. GOL'DENBERG. *Sibko i Keram.* 5 [6] 4-6 (1948). The chief source of sulfate for glassmelting in the Soviet Union is the region near the Aral Sea. This sulfate is characterized by nonuniformity in chemical composition, 3 to 4% CaSO₄, and 3 to 4% NaCl. On the basis of literature data, G. concludes that the following variations in contents are allowable: Na₂SO₄, 1.25; CaSO₄, 0.3; MgSO₄, 0.35; NaCl 1.25, and insoluble residue 0.15%. The absolute contents of the components should be established yearly on the basis of data obtained from sections to be mined. The present system of sorting sulfate into grade I (not less than 90% Na₂SO₄) and grade II (not less than 80% Na₂SO₄) should be abolished. Instead, storage, transport, and mixing should be so arranged as to give the average composition required for glassmelting. **Criticisms:** N. K. DUBRUV, A. G. RAPA, AND I. B. SULALIS. *Ibid.*, [7] 19-20. In using Aral sulfate the dosage of reducing agent should be sufficient to take care of the sulfate and also of the admixtures of chlorides and CaSO₄. The beneficial effects of NaCl and CaSO₄ in Aral sulfate in accelerating the glassmelting process are doubted. Reduction of CaSO₄ yields CaS which changes into CaO slowly and with difficulty. The maximum content of admixtures should not exceed 4%. By improved mining methods and stricter chemical control it is possible to supply to the glass plants Aral sulfate with 88 ± 2% Na₂SO₄, and to keep the variations of NaCl within ± 2%. Sulfate of a composition suitable for glassmelting can be obtained by establishing central mixing stations in the field or by classifying the pits into groups for exploitation. B. Z. K.

ASTM S. I. METALLURGICAL LITERATURE CLASSIFICATION

1	2	3	4	5	6	7	8	9	10	11	12	13	14	15	16	17	18	19	20	21	22	23	24	25	26	27	28	29	30	31	32	33	34	35	36	37	38	39	40	41	42	43	44	45	46	47	48	49	50	51	52	53	54	55	56	57	58	59	60	61	62	63	64	65	66	67	68	69	70	71	72	73	74	75	76	77	78	79	80	81	82	83	84	85	86	87	88	89	90	91	92	93	94	95	96	97	98	99	100
---	---	---	---	---	---	---	---	---	----	----	----	----	----	----	----	----	----	----	----	----	----	----	----	----	----	----	----	----	----	----	----	----	----	----	----	----	----	----	----	----	----	----	----	----	----	----	----	----	----	----	----	----	----	----	----	----	----	----	----	----	----	----	----	----	----	----	----	----	----	----	----	----	----	----	----	----	----	----	----	----	----	----	----	----	----	----	----	----	----	----	----	----	----	----	----	----	----	----	-----

2

PROCESSES AND PROPERTIES NOTE
Heat and draft characteristics of tank furnaces. I. G. Gou'nikhurov. *Nekko i Keram*, 5 [0] 5-9 (1948). The generally accepted method of determining the draft characteristics of tank furnaces on the basis of normal fuel and average take off of glass should be discarded because of variations of both factors. The method proposed by A. A. Skvortsov. *Eksp. Topiva*, 1948, No. 4, pp. 4-7 for determining the heat and draft characteristics of open hearth furnaces should be applied to glassmelting furnaces. B. Z. K.

ASME 5.1.1 METALLURGICAL LITERATURE CLASSIFICATION

1	2	3	4	5	6	7	8	9	10	11	12	13	14	15	16	17	18	19	20	21	22	23	24	25	26	27	28	29	30	31	32	33	34	35	36	37	38	39	40	41	42	43	44	45	46	47	48	49	50	51	52	53	54	55	56	57	58	59	60	61	62	63	64	65	66	67	68	69	70	71	72	73	74	75	76	77	78	79	80	81	82	83	84	85	86	87	88	89	90	91	92	93	94	95	96	97	98	99	100
---	---	---	---	---	---	---	---	---	----	----	----	----	----	----	----	----	----	----	----	----	----	----	----	----	----	----	----	----	----	----	----	----	----	----	----	----	----	----	----	----	----	----	----	----	----	----	----	----	----	----	----	----	----	----	----	----	----	----	----	----	----	----	----	----	----	----	----	----	----	----	----	----	----	----	----	----	----	----	----	----	----	----	----	----	----	----	----	----	----	----	----	----	----	----	----	----	----	----	-----

1ST AND 2ND ORDERS PROCESSES AND PROPERTIES INDEX 1ST AND 4TH ORDERS

C

5

Specific pickup of glassmelt as a function of the charge composition. G. M. ASIKINAZI AND L. G. GOLDBERG. *Steklo i Keram.* 5 (10) 3-7 (1948). Production data of window glass plants for a 4 1/2 year period were studied. The plants used charges of 100 sulfate, 10 to 30 soda, 40 to 60 soda, and 70 to 90% soda. A nomograph was constructed showing specific pickup as a function of charge composition and melting temperature. Calculations were based on a charge containing fluor spar admixture and fed in batch piles. For a charge without fluor spar, the pickup values are multiplied by 0.9; for thin layer charging, the pickup values are multiplied by 1.12. The nomograph makes it possible to analyze tank operations with an accuracy sufficient for practical purposes. BZK

CLASSIFICATION

METALLURGICAL INDEX

A.S.T.M. METALLURGICAL LITERATURE CLASSIFICATION

47 2 22 77

1	2	3	4	5	6	7	8	9	10	11	12	13	14	15	16	17	18	19	20	21	22	23	24	25	26	27	28	29	30	31	32	33	34	35	36	37	38	39	40	41	42	43	44	45	46	47	48	49	50	51	52	53	54	55	56	57	58	59	60	61	62	63	64	65	66	67	68	69	70	71	72	73	74	75	76	77	78	79	80	81	82	83	84	85	86	87	88	89	90	91	92	93	94	95	96	97	98	99	100
---	---	---	---	---	---	---	---	---	----	----	----	----	----	----	----	----	----	----	----	----	----	----	----	----	----	----	----	----	----	----	----	----	----	----	----	----	----	----	----	----	----	----	----	----	----	----	----	----	----	----	----	----	----	----	----	----	----	----	----	----	----	----	----	----	----	----	----	----	----	----	----	----	----	----	----	----	----	----	----	----	----	----	----	----	----	----	----	----	----	----	----	----	----	----	----	----	----	----	-----

C

9

Construction of tanks. I. G. GORDENBERG, V. I. GORBUNOV,
AND M. M. ZAGORCHIK. *Soviet Chem.* 5 (1967) 21-22; ENR.
A cooling area which is 90 to 95% of the neck area is considered
sufficient. If necessary, the neck should be narrowed in order to
cool the glass melt to the required viscosity. (U.S.S.R.)

ASME SEVEN METALLURGICAL LITERATURE CLASSIFICATION

SEVEN METALS

1	2	3	4	5	6	7	8	9	10	11	12	13	14	15	16	17	18	19	20	21	22	23	24	25	26	27	28	29	30	31	32	33	34	35	36	37	38	39	40	41	42	43	44	45	46	47	48	49	50	51	52	53	54	55	56	57	58	59	60	61	62	63	64	65	66	67	68	69	70	71	72	73	74	75	76	77	78	79	80	81	82	83	84	85	86	87	88	89	90	91	92	93	94	95	96	97	98	99	100
---	---	---	---	---	---	---	---	---	----	----	----	----	----	----	----	----	----	----	----	----	----	----	----	----	----	----	----	----	----	----	----	----	----	----	----	----	----	----	----	----	----	----	----	----	----	----	----	----	----	----	----	----	----	----	----	----	----	----	----	----	----	----	----	----	----	----	----	----	----	----	----	----	----	----	----	----	----	----	----	----	----	----	----	----	----	----	----	----	----	----	----	----	----	----	----	----	----	----	-----

C

11

Dependence of tank output on the operation of regenerators
E. G. GOLDBERG. *Stal' i Kuzn.* 5:11:7-17, 1948. The
existing tank furnace regenerators are designed for heating gas
and air up to 900° to 1000°C. This assures high tank tempera-
tures only if the tank is fired with high calorific gas. By raising
the gas and air in the regenerators to 1200°, high temperatures
(1450° to 1480°) in the tank are attainable by firing the tank with
gas of 750 to 950 cal./m³. The gas can be heated to 1200° pro-
vided the central wall of the regenerators is increased in width
and is constructed with great care. To achieve higher gas and
air temperatures, the regenerator roofs should be made of Dinas
instead of fire clay brick, and the central walls and the lining of
the outer walls should be of Dinas for half their height. Various
measures for improving operation of existing regenerators are
discussed. B.Z.K.

ASIA 11.6 METALLURGICAL LITERATURE CLASSIFICATION

E 2

1	2	3	4	5	6	7	8	9	10	11	12	13	14	15	16	17	18	19	20	21	22	23	24	25	26	27	28	29	30	31	32	33	34	35	36	37	38	39	40	41	42	43	44	45	46	47	48	49	50	51	52	53	54	55	56	57	58	59	60	61	62	63	64	65	66	67	68	69	70	71	72	73	74	75	76	77	78	79	80	81	82	83	84	85	86	87	88	89	90	91	92	93	94	95	96	97	98	99	100
---	---	---	---	---	---	---	---	---	----	----	----	----	----	----	----	----	----	----	----	----	----	----	----	----	----	----	----	----	----	----	----	----	----	----	----	----	----	----	----	----	----	----	----	----	----	----	----	----	----	----	----	----	----	----	----	----	----	----	----	----	----	----	----	----	----	----	----	----	----	----	----	----	----	----	----	----	----	----	----	----	----	----	----	----	----	----	----	----	----	----	----	----	----	----	----	----	----	----	-----

SECRET

The following information is being furnished to you for your information only. It is not to be disseminated outside your agency.

: [Illegible text]

C

Thermal insulation of tank furnaces as a means of increasing their output. L. G. GOLDBERG. *Svetlota i Keram.* 6 [2] 6-11 (1949). Thermal insulation of tank furnaces is an important factor in raising their output when low calorific gas is used as fuel. The structure of insulated Dinas is improved because of the almost complete transformation of the quartz into more stable modifications of silica. Insulation should be carried out in definite order: those sections which are subject to least wear should be insulated first, while those which are subject to the most wear should be insulated after all operating and constructional measures to reduce such wear have been applied. The chief purpose of insulating the roof is to improve its structure for which it is sufficient to raise the temperature of the Dinas under the insulation to 850° to 900° C. In computing insulation for worn sections of brickwork, their thickness should be considered as not over 1/2 of the original thickness. The average temperature of the Dinas should not be over 1350°. The temperature at the boundary with grog lightweight brick should not exceed 1200° and with diatomite 1000°. B. Z. K.

ASAC 53.6 METALLURGICAL LITERATURE CLASSIFICATION

Prevention of the Formation of Alkali Bubbles and Discoloration of the Glass in Tank Furnaces. By Russian: I. I. G. Goldenberg, H. V. A. Follak, A. G. Bepa, and I. D. Tkachinski. *Steklo i Keramika* (Glass and Ceramics), Moscow, 1969, p. 11-17.

In Part I, heating the glass mass in a slightly acidic atmosphere is recommended. Introduction of solid reducing agents in amounts depending on the amount of SO_2 present is also recommended. In Part II alkali-bubbles representing inclusions of fused sulfate are distinguished from gaseous sulfate bubbles. Investigation revealed that the general cause of alkali-bubble formation is supersaturation of the glass mass by free undissociated sulfate, and its liberation in the form of alkali inclusions. Data are tabulated.

ASAC U.S.A. METALLURGICAL LITERATURE CLASSIFICATION

1	2	3	4	5	6	7	8	9	10	11	12	13	14	15	16	17	18	19	20	21	22	23	24	25	26	27	28	29	30	31	32	33	34	35	36	37	38	39	40	41	42	43	44	45	46	47	48	49	50	51	52	53	54	55	56	57	58	59	60	61	62	63	64	65	66	67	68	69	70	71	72	73	74	75	76	77	78	79	80	81	82	83	84	85	86	87	88	89	90	91	92	93	94	95	96	97	98	99	100
---	---	---	---	---	---	---	---	---	----	----	----	----	----	----	----	----	----	----	----	----	----	----	----	----	----	----	----	----	----	----	----	----	----	----	----	----	----	----	----	----	----	----	----	----	----	----	----	----	----	----	----	----	----	----	----	----	----	----	----	----	----	----	----	----	----	----	----	----	----	----	----	----	----	----	----	----	----	----	----	----	----	----	----	----	----	----	----	----	----	----	----	----	----	----	----	----	----	----	-----

PROCESSES AND PROPERTIES INDEX

Service of zircon-mullite burner port. L. G. GOLDBERG, *Sivko i Kuzom*, 6 [0] 22 (1949). During cold repairs of a tank furnace, the port of the first pair of burners was changed from Dinas to zircon mullite material. Operating conditions were as follows. Maximum temperature in the region of 2nd and 3rd pairs of burners was 1460° to 1470°. The temperature between the 1st and 2nd pairs of burners was 1430° to 1440°. The charge consisted of 80 to 100% sulfate with a moisture content of 6 to 11%. The rate of charge was 4.5 tons/hr. Prior to repairs, charging was by means of a mechanical pusher and, after repairs, by means of a Thin Layer Feeder. After 6 months service, the port was in good condition while the Dinas ports of the 2nd and 3rd pairs of burners were worn to a considerably greater extent. Details of construction are illustrated. B.Z.K.

ASA S.L.A. METALLURGICAL LITERATURE CLASSIFICATION

GROUP	ALPHABETIC	CYCLIC	NUMERIC
S	1	2	3
D	4	5	6
U	7	8	9
C	0	1	2
A	3	4	5
M	6	7	8
L	9	0	1
I	2	3	4
K	5	6	7
H	8	9	0
G	1	2	3
F	4	5	6
E	7	8	9
B	0	1	2
N	3	4	5
O	6	7	8
P	9	0	1
Q	2	3	4
R	5	6	7
S	8	9	0
T	1	2	3
V	4	5	6
W	7	8	9
X	0	1	2
Y	3	4	5
Z	6	7	8
AA	9	0	1
AB	2	3	4
AC	5	6	7
AD	8	9	0

CA

Combating the formation of alkaline bubbles and discoloration of glass melt in tank furnaces. I. G. Goldenberg. *Steklo i Keram.* 6, No. 11, 11-14 (1949). **Atk.** bubbles occur chiefly when sulfate charge is used and to a smaller degree when soda charge is used with small admixts. of sulfate. Data obtained from the Dzerzhinskii glass works indicate that by decreasing the sulfate and the reducing agent or by operating for a month without reducing agent, the SO_2 in the glass melt increased from 0.5-0.6% to 0.8-0.9%. In the absence of gall in the furnace, sulfate was increased to 10%; this caused alk. boil to appear in the glass sheet and analysis showed up to 0.8-0.9% SO_2 . Increase of sulfate to 20% and addn. of 6% C caused alk. boil to disappear and SO_2 dropped to 0.4-0.5%. These data were obtained during the period prior to repairs when temp. was maintained at 1250-1300° and the atm. in the furnace was reducing because regenerator nozzles were clogging up. The curve of C content for 1 yr. resembled a sine curve; the max. (14-15% C) occurred immediately after cold repairs and replacement of regenerator nozzles while the min. (4-3% C) occurred im-

mediately prior to the repairs. Min. content (0.3-0.4%) of SO_2 , which corresponds to complete reduction of sulfate, was attained after nozzles were replaced or 2-30 days after cold repairs. The periods of min. content of SO_2 almost always corresponded to the max. C content (14-15%) and, hence, to an oxidizing atm. in the furnace. These occurrences can be explained by the phenomenon of more complete reduction of the sulfate in an oxidizing atm. When "gas" discoloration of the melt occurs frequently, the addn. of solid reducing agent is decreased. As a result, particles of sulfate in the charge are not reduced but are dissolved in the melt, increasing the SO_2 content to the limit of solv. of the Na_2SO_4 (1.83% SO_2), and the sulfate seps. from the supersatd. soln. in the form of alk. bubbles and boil during the subsequent cooling of the melt. If the atm. in the tank is oxidizing, a considerable portion of the C is burned to CO_2 before it reacts with the sulfate but this is easily compensated by an increase in the total C in the charge which reduces the sulfate particles within the charge. In the absence of forced draft in the regenerators, the nozzles become clogged up, causing the atm. in the tank to become reducing. The surface in the melting zone becomes covered with foam and the gall disappears, causing the melt to decrease the addn. of C. The gall then begins to appear in the refining zone, in the region of the 4th and 5th burners.

Handwritten signature

where the smoky flame comes into contact with the surface gull and reduces it to sulfides, which discolor the melt in accordance with $\text{Na}_2\text{SO}_4 + \text{Na}_2\text{S} = 2\text{Na}_2\text{O} + \text{SO}_2 + \text{S}$. To eliminate alk. bubbles and discoloration, the following measures are suggested: (a) melting of soda and soda-sulfate charges should be conducted in a weakly oxidizing atm., (b) solid reducing agents should be added even when the sulfate content of the charge is a min., (c) the amt. of reducing agent added should be detd. not only from appearance of the glass melt but also on the basis of the SO_2 content in glass, and (4) forced draft should be installed in regenerators of all tank furnaces. V. V. Pollyak, A. G. Repa, and I. D. Tykuchinski. *Ibid.* 14-17. The supersatn. of the melt with undecompd. sulfate may also be caused by the reforming of sulfate in low-temp. zones in the presence of S gases in the tank atm. Reduction of sulfate is facilitated not by the weakly oxidizing atm. but by the accompanying effects. In the absence of means to control the compn. and pressure of the gas medium, the maintenance of a reducing medium in the furnace involves operation under pressure which hinders the course of reactions accompanied by the evolution of gases, lowers the intensity of the turbulent action of the gases in glass melting, and, under certain conditions, neutralizes the beneficial effects of the reducing atm. In a weakly oxidizing atm. in the furnace, there will be a slight vacuum above the layer of charge in the furnace and the action of the gases will be facilitated. When sulfate is added to a soda charge in amts. corresponding to 3-5% of the total alkali content, it decomps. completely without the addn. of a reducing agent; C should be added only when sulfate exceeds the amts. Other suggestions made by G. are being applied in industry. B. Z. K

X

Combating formation of alkaline bubbles and discoloration of glass melt.

L. G. Gol'denberg. *Steklo i Keram.* 7, No. 5, 213 (1930); cf. C.A. 44, 8072g. --Greatest practical factor in formation of alk. gas bubbles is the incomplete decompn. of the sulfate. With 5% sulfate in the charge, the chief source of SO₂ in furnace gases is the fuel (coal); when sulfate is increased to 20%, the amt. of SO₂ from fuel and charge is equal. For melting high-quality glass, the fuel should have a min. of S, and sulfate should not exceed 5%. For a min. content of SO₂ (0.3%) there is a min. amt. of bubbles and seed. Detn. of SO₂ indicates decompn. of sulfate is incomplete. When the atm. in the furnace is weakly oxidizing (or neutral, if possible), the metal surface will characterize the condition within and the correct amt. of reducing agent can be established by observing the presence of small patches of molten undecompl. sulfate in the furnace. When the atm. is reducing and the correct amt. of solid reducing agent is maintained, there will be considerable foaming and, in some cases, coloration of the surface layers of the melting charge by the gases. Ordinarily it is difficult to det. whether discoloration is caused by the charge or by the gases. As an aid to the operators, it is not desirable to obscure the process by the addnl. reduction of sulfate layers with furnace gases. The reducing agent should not be ground too finely; the important factor in the reduction is the washing of the sulfate particles with CO bubbles and, if the reducing agent is too finely ground, the CO bubbles will not possess enough lifting power to rise through the charge. Pressure variations in the tank are too small to affect the process. B. Z. Kamich

2

Reducing wear of Dinas in tanks. I. G. GOLDBERG.
Steklo i Keram. 8 [2] 8-12 (1951) -- Common problems and suggested remedies are given, including redesign of crown arch skew, burner, and arch of regenerators. A tank arch should be at a sufficient distance from the flame so as not to make contact. The charge should be moistened or briquetted. Temperatures above normal for the tank should not be employed. B. Z. K.

BCS

Plus

1228. *Building glass tanks for sheet glass.*—L. G. GOLDENBERG and G. V. PITOTSKAYA (*Sov. Keram.*, 8, No. 10, 19, 1951). To achieve complete purification of sheet glass the max. temp. should be maintained in tanks between the 2nd and 3rd burners; the temp. curve should fall smoothly towards the chamber below the machine, in front of the screen there should be a non-reaction zone of sufficient size with a temp. maintained at $< 1,300$ C. A high degree of homogenization can be achieved if glass remains for a long time in the furnace and if there are intense free convection streams between the refining and cooling parts of the tank. The tank should be rectangular without any narrowing in the screen region or where the machine channel starts. It is advisable to build tanks with large refining and cooling areas, since this will make it possible to increase the temp. as well as the output. The thermal efficiency per unit output of large-size tanks is higher than that of small tanks. The optimum temp. should be determined for each tank individually. Tank construction with complete isolation of the melting zone and with the glass flowing vertically is favoured. The size of a tank could be reduced by mechanical mixing; this problem should be solved as soon as possible.

1. [Illegible]
2. [Illegible]
3. [Illegible]
7. [Illegible]

9. Monthly List of Russian Addresses, Moscow, [Illegible], [Illegible]

USSR/ Engineering - Glass furnaces

Card 1/1 Pub. 104 - 4/12

Authors : Gol'denberg, L.G.

Title : Water cooling of bath type glass furnaces

Periodical : Stek. i ker. 1, 11-17, Jan 1954

Abstract : The advantages and disadvantages of using water cooling systems for bath-type glass furnaces are discussed. The wear of the inside furnace refractories depends upon their surface temperature and the viscosity of the glass mass with which these surfaces come in direct contact. The basin of a glass furnace as well as other construction elements cannot be insulated but must be cooled and it is also necessary to increase the viscosity of the glass mass in order to compensate for the corrosive action of the glass mass convection due to cooling. Drawings of water cooled glass furnaces (including one USA) are included. Eleven references: 9 USSR and 2 USA (1891-1953). Drawings; illustrations.

Institution:

Submitted:

USSR/ Engineering - Industrial processes

Card 1/1 Pub. 104 - 3/11

Authors : Gol'denberg, L. G.

Title : Rational layout of a compound plant

Periodical : Stok. i ker. 4, 7-9, Apr 1954

Abstract : The melting of glass, in glass furnaces, not equipped with special devices for intensive stirring of the glass mass, requires the application of batches of high degree of homogeneity. The system of chemical control and frequent corrections of the batch is in itself a source of many errors and is therefore considered as imperfect. The high quality of the batch can be secured only through a working plant organization, which would make the origination of errors impossible. The author suggests a rational layout of a compound plant where the quality of the batch and the ready product can be maintained at a high level. Nine USSR references (1945-1953). Diagram.

Institution:

Submitted:

GOL'DENBERG, L.G.

USSR/Miscellaneous

Card 1/1 : Pub. 104 - 12/14

Authors : Gol'denberg, L. G.

Title : Use of containers for intrafactory transportation of refractories

Periodical : Stok. i ker. 10, 27-29, Oct 1954

Abstract : The mechanization of intrafactory transportation of refractories, by the adoption of the conveyer belt system, is described. The economical and technical advantages derived from such a change over are listed.

Institution : ...

Submitted : ...

GOL'DENBERG, L. G.

USSR/Chemistry - Glass crystallization

Card : 1/1 Pub. 104 - 10/12

Authors : Belova, B. M. and Gol'denberg, L. G.

Title : Diopside in window glass

Periodical : Stek i ker. 11/7, 27, June 1954

Abstract : A description is given of the formation of crystals in glass, which proved to be crystals of diopside. Through experiences with such crystallization it was found that the magnesium oxide content in glass should be reduced to 4.5% and the calcium oxide content to 6.5% to prevent such crystallization. Illustration.

Institution : ...

Submitted : ...

GOLDENBERG, L.S.

MT

78. The use of containers for the handling of refractories within the plant. - L. G. Gordin and G. G. Gordin, *Glass & Ceramics*, Moscow, 11, No. 10, 27, 1954. Refractories in 2947
On belt conveyors get damaged; sheet-metal containers moved by cranes are a preferable method of handling. (5 figs.)

USSR/Chemical Technology - Chemical Products and Their Application. Silicates.
Glass. Ceramics. Binders, L.

Abst Journal: Referat Zhur - Khimiya, No 19, 1956, 62275

Author: Gol'denberg, L.G.

Institution: Central Scientific Research Laboratory of Electrotechnical Glass

Title: TsNILES Tank Furnace for Melting of 3S-5k Glass

Original

Periodical: Inform.-tekh. sb. Tsentr. n.-i. labor. elektrotekh. stekla,
1955, No 3, 39-50

Abstract: On the basis of investigations of specific features of the process of melting of high-boron glass 3S-5k, the phenomena of borate volatilization and crystallization process, there is proposed a new design of a 3-zone tank furnace provided with evaporation chamber and circulation arrangements connecting melting, refining and production sections. There is proposed a more gas-tight arrangement of the crown and use of quartz-wall refractories for the lining of pools and conduits. On the basis of a comparison with

Rm

Matts

1170. The optimum composition of window glass. G. Gol'ovinskiy and V. V. POLYAK. (*Glass & Ceramics*, Moscow, 12, No. 12, 1965, 1935) in Russian. A survey of the literature suggests that the recommendation made by the Russian Glass Institute that window-glass for vertical openings should contain 4% MgO and 2% CaO should be taken into account the conditions of glass-cooling. According to the authors, glasses with better working properties (higher viscosity and surface tension) contain 4-5% CaO and 4-5% MgO. (4 figs., 1 table)

271 ←

GINZBURG, David Borisovich, doktor tekhnicheskikh nauk; DELIKISHKIN, Sergey Nikolayevich, kandidat tekhnicheskikh nauk; KHODCROV, Yevgeniy Iosifovich, kandidat tekhnicheskikh nauk; CHIZHSKIY, Anatoliy Fedotovich, kandidat tekhnicheskikh nauk; ZIMIN, V.N., dotsent, retsenzent; KUZYAK, V.A., dotsent, retsenzent; NOKHRATYAN, K.A., kandidat tekhnicheskikh nauk, retsenzent; IVANOV, A.N., dotsent, retsenzent [deceased]; BUDNIKOV, P.P., redaktor; FRADKIN, A.Ye., kandidat tekhnicheskikh nauk, nauchnyy redaktor; GOL'DENBERG, L.G., inzhener, nauchnyy redaktor; GLEZAROVA, I.L., redaktor; GLADKIKH, N.N., tekhnicheskiy redaktor

[Furnaces and driers in the silicate industry] Pechi i sushila silikatnoi promyshlennosti. Izd. 2-ye, perer. Pod red. P.P.Budnikova. Moskva, Gos. izd-vo lit-ry po stroit. materialam, 1956. 455 p.
(MLR 10:3)

1. Deystvitel'nyy chlen Akademii nauk USSR (for Budnikov)
(Kilns) (Clay industries)
(Drying apparatus)

15 (2)

AUTHORS:

Gol'denberg, L. G., Levina, A. P.,
Matyusha, S. I.

S/072/60/000/02/001/021
E015/E003

TITLE:

Experience made by the Introduction of Tank Furnaces With
Direct Heating

PERIODICAL:

Steklo i keramika, 1960, Nr 2, pp 1 - 5 (USSR)

ABSTRACT:

In the present paper the authors describe two tank furnaces of this type designed by the Nauchno-issledovatel'skiy institut elektrotekhnicheskogo stekla (NIIES Scientific Research Institute for Electrotechnical Glass) and installed in the Saratov works in 1957-1958 for the manual processing of borosilicate glass. S. L. Rassadin participated in the design of the first furnace. N. S. Snezhinskiy and N. V. Filimonovich constructed the latter. Figure 1 shows the tank of the first furnace, and figures 2 and 3 show both burner types. The first burner type was designed by B. G. Lukin, the second burner is a standard construction of the "Stal'proyekt". Figure 4 shows the metal recuperator. Compressed air is produced by means of a BK-6 ventilator made by the Zagorskiy zavod sel'skokhozyaystvennogo

Card 1/2

Experience Made in the Introduction of Tank
Furnaces With Direct Heating

3/072/EO/000/02/001/021
B015/B003

mashinostroyeniya (Zagorsk Works for Agricultural Machine Construction). Yu. A. Gastev, L. V. Potemkina, Ye. I. Usova, and N. V. Filimonovich, collaborators of NIIES, as well as M. M. Lagranskiy, V. N. Morozov, S. G. Ponomarev, and V. V. Tyurin, collaborators of the afore-mentioned works, participated in putting the furnace into operation. After a campaign of 14 months the furnace superstructure was in good condition. In the middle of 1958 the second tank furnace of this type with slightly modified dimensions was put into operation in the same works (Figure 5). In conclusion, the authors state that these types warrant high technological qualities and optimum temperature- and gas conditions in the tank and in the processing part of the furnace. These furnaces also exhibit thermal and operational advantages. The limited dimensions of the melting tank and the resulting limited capacity (up to 80 t per day) are indicated as drawbacks of these furnaces. There are 5 figures. ✓

GOL'DENBERG, L.G., inzh.

Design of feeders with gas heating. Stek.1 ker. 19 no.12:3-7
D '62. (MIRA 16:1)

(Glass furnaces)

SHCHEGLOV, Yu.A.; GOL'DENBERG, L.G.; FAKTOROVICH, A.A.; KRASNOCHE, K.Ya.

Automation of cut tomatoes receiving points and pumped transfer
points of continuous lines in tomato processing. Izv. AN Mold.
SSR, no.3:107-112 '63. (MIRA 17:12)

GOL'DENBERG, U.S.S.R. (trans); FRUZHANSKIY, A.M. (trans); SMITULIN, V. I. (trans).

Design of gas and electrically heated glass turbines. 116k.
1 ker. 21 no. 7:6-11 31 '64. (MIRA 17:10)

ACC NR: AP6030158

SOURCE CODE: UR/0120/66/000/004/0204/0205

AUTHOR: Gol'denberg, L. G.; Denisov, A. A.

ORG: Leningrad Polytechnical Institute (Leningradskiy politekhnicheskiy institut)

TITLE: Regulated low-power, high-voltage source

SOURCE: Pribory i tekhnika eksperimenta, no. 4, 1966, 204-205

TOPIC TAGS: power supply, *high voltage line*

ABSTRACT: An adjustable high-voltage supply with an output voltage of up to 20 kv and a current of 0.1 mamp is described. The generator (see Fig. 1) is a balanced-bridge type with its output polarity controlled by the polarity of the input voltage. Positive feedback is obtained from separate windings of sweep transformers T₁ and T₂. Tube V7 is a balanced multivibrator with a frequency of 18 kc; its output together with the feedback signal is applied to the grids of tubes V6 and V8. Tubes V2 and V4 are damping diodes, and V1 and V5 are rectifiers with output voltages of 12—13 kv without and 18—20 kv with positive feedback. Two salient features of the source are its stability for a wide range of component tolerances and its variable output voltage. The output voltage remains constant for resistor and

L 44320-66

ACC NR: AP6030158

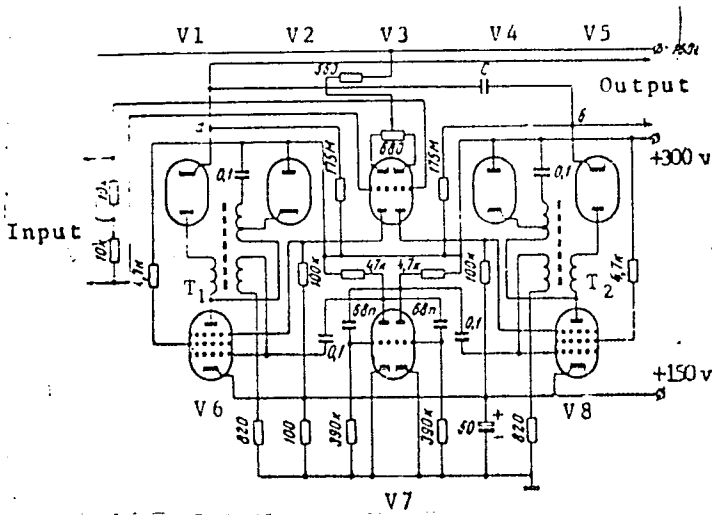

capacitor tolerances of $\pm 30\%$ and can be continuously varied from 0 to ± 18 kv by changing the cathode resistances of tube V3. Orig. art. has: 2 figures. [IV]

SUB CODE: 09/
 SUBM DATE: 02Jul65
 ORIG REP: 002
 ATD PRESS: 5072

Fig. 1. Voltage supply schematic

ACC NO: AP7004783

SOURCE CODE: UR/0413/67/000/002/0000/0000

INVENTOR: Denisov, A.A.; Gol'denberg, L.G.; Reshetikhin, N.V.

ORG: none

TITLE: Electropneumatic (electrohydraulic) converter. Class 42, No. 198898 [announced by Leningrad Polytechnical Institute im. M.I. Kalinin (Leningradskiy politekhnicheskii institut)]

SOURCE: Izobreteniya, promyshlennyye obratzyy, tovarnyye znaki, no. 1, 1967, 96

TOPIC TAGS: electropneumatic control, pneumatic device, hydraulic device, *ELECTRO MECHANIC CONVERTER*

ABSTRACT:

An Author Certificate has been issued for an electropneumatic (electrohydraulic) converter which employs the action of a homogeneous electrostatic or electromagnetic field on a jet of gas or of liquid, with preliminary application of a surface charge to the jet. The converter contains a jet-forming nozzle, corona-producing electrodes, a deflecting system, and receiving nozzles. These nozzles are symmetrically positioned in relation to the axis of the jet-forming nozzle, and the electrostatic or

Card 1/2

UDC: 681.142-525

ACC NR: AP7004783

electromagnetic deflecting system is placed in the interval between the receiving nozzles and the corona-producing electrodes. Converter action

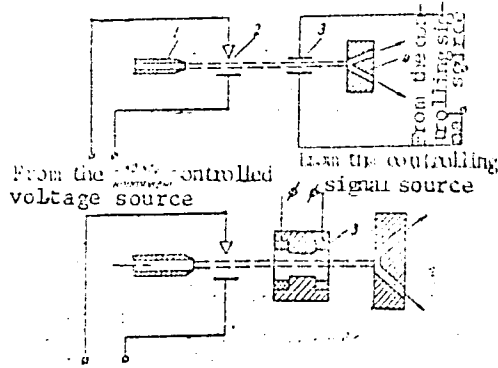

Fig. 1. Converter

- 1 - Nozzle;
- 2 - corona-producing electrodes;
- 3 - deflecting system;
- 4 - receiving nozzles.

is therefore increased and system reliability improved. Orig. art. has: 1 diagram. [JP]

SUB CODE: 13/ SUBM DATE: 11June65/ ATD PRESS: 5116

SMIRNOV, V.A. (Moskva); GOL'DENBERG, L.I. (Moskva)

Affection of the nervous system following rabies vaccination.
Klin. med. 35 no.2:114-118 P 157 (MIRA 10:4)

1. Iz kliniki nervnykh bolezney (dir.-prof. I.N. Pilyonov)
II Moskovskogo meditsinskogo instituta i nervnogo otdeleniya
2-y Gorodskoy bol'nitsy imeni Veysbroda (glavnyy vrach A.I.
Khromova)

(RABIES, prev. & control
vacc., causing lesions of NS)
(NERVOUS SYSTEM, dis.
caused by rabies. vacc.)

GOL'DENBERG, L.I.

Use of iodobromine baths for the treatment of the initial forms of cerebral atherosclerosis. Vop. kur., fizioter. i lech. fiz. kul't. 25 no. 6:525-531 N-D '60. (MIRA 14:2)

1. Iz nevrologicheskogo otdeleniya (zav. - prof. N.S. Chetverikov) Nauchno-issledovatel'skogo instituta kardiologii i fizioterapii v Moskve (dir. - kand. med. nauk G.N. Pospelova).
(KNOBYZHENSKI--MINERAL WATERS) (ARTERIOSCLEROSIS)

GOLDENBERG, L.I.

Production and application of alloyed and special cast-iron.
Lit. proizv. no.10:1-3 N-D '53. (NERA 6:12)
(Iron alloys) (Cast-iron)

GOLDENBERG, L.I.

Distr: 4E2c

Basic problems of selecting high-quality charge materials and of melting technology. L. I. Goldenberg. *Science Proceedings* 1937, No. 10, 2214. General comments of the selection of iron and steel scrap for cupola melting and the practice to be used. Heredity of iron is emphasized.

J. D. Gort

2

[Handwritten signature]

Translation from: Referativnyi zhurnal. Metallurgiya, 1958, No. 8, p. 15 (USSR)

AUTHOR: Gol'denberg, L. I.

TITLE: Gray Cast Irons of Improved Quality Manufactured by Electric Arc Furnaces (Mestnykh shvykovykh chugunov.)

PERIODICAL: V sb. Materialy Soeshchannogo nauchnogo i tekhnicheskogo seminarov prom. st. Nr. 2, Moscow, 1958, pp. 14-16.

ABSTRACT: The quality of cast iron (CI) has a direct bearing on the amount of spoilage in casting production. Metallurgical studies performed on gray CIs manufactured in electric furnaces made it possible to analyze the properties peculiar to certain types of CI. It was established that, depending on their quality, the gray CI manufactured in blast furnaces may be arranged as follows: gray CI manufactured by 1) Zaporozhsk plant; 2) Voroshilov plant; 3) Krivirozhsk plant; 4) Dnepropetrovsk plant; 5) Chelyabinsk plant; 6) Kuznetsk Kombinat; 7) Apatovsk plant; 8) Nizhny Tagil plant; and 9) Magnitogorsk Metallurgical Kombinat. In order to eliminate spoilage, it is essential that the requirements for gray CI be revised by taking into consideration the extent of its contamination with nonmetallic inclusions.

Card 1-2

SOV 137-58-8-17763

Gray Cast Irons of Improved Quality

and that research be performed in order to arrive at standardized values of total C content depending on the grade of CI. Fluctuations in weight of CI pigs must not exceed 20 kg. It is also necessary to revise the existing GOST regulations regarding gray CI so as to arrive at a system whereby gray CI from every supplying region would have its own waybill fully describing its quality characteristics.

A. S.

1. Cast iron--Production
2. Cast iron--Quality control

Card 2/2

00014-00-00-01

AUTHOR: I. I. Gerasimov, L. I. Gerasimov, and V. A. Gerasimov

TITLE: The USSR Standard Project for the Pig Iron (Project: GOSTa na koksnyy chushkovyy litnyy zhelezno)

PERIODICAL: Metallurgiya, 1958, No. 1, pp. 101-103

ABSTRACT: The project of the new state standard, GOST 1934-58 for foundry pig iron, to replace GOST 1934-55, is described. It is pointed out that the grades LK-00 and LK-0 have been deleted and a new, LK-50, grade with silicon content of 0.75-1.25% introduced. In 1958 6 to 10% of the total 6 million tons of foundry iron produced will be in the two deleted grades. The yearly requirement for ferrasilicon, after the new standard comes into effect, is herein calculated. The published project is presented by the Nauchno-issledovatel'skiy institut Chernoy metallurgii (Central Scientific Research Institute of Ferrous Metallurgy).

1. Iron. GOST. 2. Iron-silicon alloys. 3. Iron. Production.

AUTHOR: Goldenberg, L.I. NY 110-58-9-5/16

TITLE: The Quality of Blast Furnace Cast Iron (kachestvo domennykh liteynykh chugunov)

PERIODICAL: Liteynoye proizvodstvo, 1968, Nr 9, pp 7-8 (USSR)

ABSTRACT: Crystallization in iron during solidification is influenced by the structure formation and admixtures, especially in the form of graphite and refining foam. The inclusions of refining foam are most numerous in plants where fluxed agglomerate is used as raw material. The content of free carbon in cast iron may be regulated by varying the time during which the liquid iron is kept in the ladles. A regulated carbon content is very important to many branches of industry. The silicon content is especially high in the cast iron brands LK-C, LK-CC, and LK-1. In LK-C it is 0.5% higher than in LK-1. For many purposes, cast iron with a manganese content of 0.5% is needed, whereas usual cast iron has a content of 0.7 - 0.9%. The state standard GOST permits a phosphorous content of 0.11 - 0.30% in cast iron.

Card 1/2

The Quality of Blast Furnace Iron

SOV-128-58-9-3/26

higher content considerably decreases the mechanical properties of the iron.

1. The iron-oxide content of the blast furnace gas is a function of the iron-oxide content of the iron.

Card 2/2

AUTHOR: S. S. Zelenberg, L.I. ... 1958, No. 10, p. 1000-1001

TITLE: On the Quality of Blast Furnace - Pig Iron
(O kachestve litmennykh ...)

PERIODICAL: Stal', 1958, No. 10, p. 1000-1001 (USSR)

ABSTRACT: An investigation of the phenomena of shrinkage of pig iron produced on blast furnaces, the shrinkage phenomena and the influence of cooling velocity of pig iron on the microstructure of the metal was carried out. Metal from 9 works (Tables 1 and 2) was tested. The testing was carried out on melting charges of 30% foundry pig and 70% scrap iron in a high frequency furnace under standard conditions (acid slag, temperature 1520-1540 °C) and casting them into metal moulds. The volume of shrinkage cavities was determined by weighing or by filling with kerosene. Higher development of shrinkage phenomena was observed for pigs contaminated with kish. It was found that during smelting of foundry-iron from raw iron and sinter on the Magnitogorsk Works or with a proportion of syderitic iron on the Chelyabinsk Works the contamination of the metal with kish is comparatively small. Casting of pig into the form of a small weight on the Cherepovets Works and

Card 12

On the Quality of Blast-Furnace Forecast Pig Irons 007/133-58-10-4/31

Magnesium combine leads to shifting of the accumulated
slag from the central part of the furnace into the solidifying
zone. With increasing iron temperature, the solubility
of slag increases and the contamination of primary iron from
slag increases. Primary iron from
slag has the highest sulfur content and is not con-
taminated with phosphorus. It is suggested that the industry should
use low sulfur primary iron and use 20% ferroilicon
to improve the quality of pig iron. The quality of
pig iron is improved by the use of blast
furnace gas and other gases and dusts.

ASSOCIATION OF IRON AND STEEL

On the Quality of Blast-Furnace Forecast Pig Irons

AUTHOR: Gol'denberg, L.I. W/128-58-12-2/21

TITLE: The New GOST-Standard for Cast Iron in Tires (Novom GOSTe na liteynnye chushkovyye chuguny)

PERIODICAL: Liteynnoye proizvodstvo, 1958, Nr 12, pp 2-3 (GOST)

ABSTRACT: Proposals for a new GOST-Standard for blast-furnace cast iron were discussed at a session of the Academic Council of the NIIChermet Institute of Steel Production. The decisions were submitted to the Committee of Standards, Measures and Measuring Devices. The reorganization of the existing GOST standard in particular concerns the new regulation of carbon content in blast-furnace cast iron. This also necessitates the reorganization of existing technology for the production of cast iron in size. It will be necessary to determine the plants serving as production bases of cast iron. In this connection it is proposed to concentrate cast iron production at the Voroshilovsk and Krivoy Rog plants (southern region), at plants situated

The New GOST-Standard for Cast Iron in Dies

81/120-55-12-2/21

near the Kursk magnetic anomaly (Central region) and at the Chelyabinsk plant in the east. The new GOST-Standard includes instructions on the composition of cast iron (table) and on the change in the ratio of the mold and die weights. A supervisory commission was appointed to deal with the introduction of the new standards. There is 1 table

Card 2/2

GOL'DENBERG, L.I.

Specilization in the blast-furnace production of foundry pig iron is a way to increase the output of acceptable castings.
Lit. proizv. no. 8:1-2 Ag '60. (MIRA 14:2)
(Foundries--Quality control) (Cast iron)

TOTSKIY, O.N., inzh.; GOL'DENBERG, L.I., inzh.

Some special aspects of the design of prestressed steel elements.
Prom. stroi. 40 [i.e. 41], no. 5:43-44. M. 1963. (MIRA 1b:5)
(Steel, Structural)

SECRET

1. The following information was obtained from a source who has provided reliable information in the past.

2. The source has provided information that is of a confidential nature and should be handled accordingly.

GOL'DENBERG, Lev Isaakovich

[Native alloy cast iron is an industrial potentiality]
Prirodnolegirovaniy chugun - rezerv promyshlennosti. Moskva, Izd-vo "Metallurgiya," 1964. 110 p. (MIRA 17:5)

1. The first part of the document discusses the importance of maintaining accurate records of all activities and the need for a systematic approach to data collection and analysis.

2. The second part of the document describes the various methods used to collect and analyze data, including interviews, surveys, and document analysis.

SHKCRUFEYEV, I.S., inzh.; GOL'DENBERG, L.L., inzh.; SIRKES, F., red.;
KUIIMAYEVA, T., tekhn. red.

[Development of the machinery and electric equipment industries
in the Moldavian S.S.R.] Razvitiie mashinostroitel'noi i elektro-
tekhnicheskoi promyshlennosti v Moldavskoi SSR. Kishinev, Gos.
izd-vo "Kartia moldoveniaske," 1960. 61 p. (MIRA 15:4)
(Moldavia--Machinery industry)
(Moldavia--Electric equipment industry)

GOL'DENBERG, I.M.

Method for expressing the hemoglobin content of an erythrocyte.
Lab.olec # no.5:2-9 S-0 '58 (MIRA 11:11)

1. Iz kafedry detskikh infektsionnykh bolezney (zav. -prof. M.N.
Bessonova) Krymskogo meditsinskogo instituta i detskoj infektsionnoy
bol'nitsy (glavnyy vrach R.F. Lyamayeva), Simferopol'.
(ERYTHROCYTES)
(HEMOGLOBIN)

SOV/124-58-5-4992

Translation from Referativnyy zhurnal, Mekhanika, 1958, No 5, p 7 (USSR)

AUTHORS Tsypkin, Ya.Z., Gol'denberg, L.M.

TITLE How to Construct a Transient Process in Automatic Control Systems From the Characteristics of Their Separate Components (Postroyeniye perekhodnogo protsessa v sistemakh avtomaticheskogo regulirovaniya po kharakteristikam ikh otdel'nykh zven'iyev)

PERIODICAL Tr. Vses. zaozn. energ. in-ta, 1957, Nr 7, pp 90-106

ABSTRACT A study is made of the problem of calculating approximately the time characteristics of closed linear systems by using transfer functions or using the time characteristics of the systems' individual components. According to the well-known formula of the theory of impulse control systems, a transition is accomplished from the continuous transfer function to a discrete transfer function. The relationship between the discrete values of the output and input values in a continuous system is written as a summation (the discrete weight function). The weight factors of this summation are equal to the coefficients of the expansion into a series of the discrete

Card 1/2

SOV/124-58-5-4992

How to Construct a Transient (cont.)

transfer function of a closed system. The author neglects to explain the fact that the formula in question, which interrelates the discrete values for input and output values, though essentially precise, nevertheless requires that the poles of the closed system's transfer function be ascertained. An approximate formula is obtained by replacing the exact discrete transfer function with a function comprising the transfer coefficients of the system's individual components. This formula does not require the solving of the closed system's characteristic equation. Simplified examples are given of the use of this procedure for the approximate determination of transient functions. An account is given of several modifications of the procedure which adapt it for use with nondirectional circuits and for determining approximately a discrete transfer function through a substitution for the independent parameter. The article contains references to works published previously on this subject.

A.A. Krasovskii

2. Control systems--Mathematical analysis

Card 2/2

GOLDENBERG, L.N. (Leningrad); MUSEEV, Yu.B. (Leningrad)

Programming of problems for digital differential analyzers. Avtom.
i telem. 22 no.11:1498-1503 N '61. (MIRA 14:12)
(Electronic differential analyzers)

GOL'DENBERG, L.M., dots.; LIPCHIN, G.S., inzh.; OKUNEV, Yu.B., inzh.;
POLYAK, M.N., inzh.; RAKHOVICH, L.M., inzh.; VEYTSMAN, G.I.,
red.; ROMANOVA, S.F., tekhn. red.

[Digital differential analyzer]TSifrovoi differentsial'nyi ana-
lizator, informatsionnyi sbornik. Moskva, Sviaz'izdat, 1962.
109 p. (MIRA 15:3)

1. Sotrudniki Leningradskogo elektrotekhnicheskogo instituta
svyazi imeni prof. M.A. Bonch-Bruyevicha (for Gol'denberg,
Lipchin, Okunev, Polyak, Rakhovich).
(Electronic differential analyzers)

BRUNOV, Boris Yakovlevich, dotsent; GOL'DENBERG, Lev Moiseyovich, dotsent; KLYATSKIN, Isay Gertsovich, prof.; TSEETLIN, Lev Aleksandrovich, dotsent; LOMONOSOV, V.Yu., prof., retsenzent; GOL'DIN, O.Ye., dotsent, red.; ZHITNIKOVA, O.S., tekhn.red.

[Theory of the electromagnetic field] Teoriia elektromagnitnogo polia. By B.IA.Brunov i dr. Moskva, Gosenergoizdat, 1962.
511 p. (MIRA 15:5)
(Electric fields) (Magnetic fields)

W. J.

... ..
niki. Izdat. Gos. Moskva, 1964, 128-vo "sviaz'," 1964, 111 p.
(RISA 17,8)

GOL'DENBERG, L.M. ; MEN'SHIKOV, G.G. ; SOBINSKIY, A.M., ed. red.

[Introduction to the technique of programming; a training manual] Vvedenie v tekhniku programirovaniya; uchebnoe posobie. Leningrad, Leningr. elektrotekhn. in-t svyazi, 1984. 46 p. (NIRA 18:7)

L 3014-66 EWT(1)/EWA(h)

AM4048141

BOOK EXPLOITATION

UR/
621.374 (075.8)

49
B+1

Gol'denberg, Lev Moiseyevich

Principles of ²⁵pulse techniques (Osnovy impul'snoy tekhniki) 2d ed. rev. Moscow, Izd-vo "Svyaz", 1964. 431 p. illus., biblio. 30,000 copies printed.

TOPIC TAGS: radio engineering, electronics, pulse signal, electrovacuum, pulse transformer, pulse generator, electronic circuit, circuit theory, semiconductor device, pulse storage, logic element, junction diode, multi-vibrator.

PURPOSE AND COVERAGE/ The book presents the basic principles in the theory and design of most important pulse devices used in various fields of radio-electronics. The main objective of the book consists in the introduction to the reader the basic concepts and methods of physical process analysis and pulse technology element design. Considered are the pulse units used in electrovacuum and semiconductor devices. The book is designated for students and can be also of use to specialists engaged in pulse technology.

TABLE OF CONTENTS (abridged):

Card 1/2

L 3014-66
AM4048141

- Ch. 1. Introduction -- 7
- Ch. 2. Pulse passing through simple linear circuits -- 34
- Ch. 3. Delay lines -- 62
- Ch. 4. Limiters and keys -- 79
- Ch. 5. Devices with impact excitation circuits -- 112
- Ch. 6. Pulse transformers -- 134
- Ch. 7. Triggers -- 152
- Ch. 8. Multivibrators -- 207
- Ch. 9. Blocking generators -- 248
- Ch. 10. Relaxator synchronization and frequency dividers -- 291
- Ch. 11. Saw-toothed shape voltage and current generators -- 310
- Ch. 12. Logical elements and junctions -- 374
- Ch. 13. Pulse selectors -- 412

Bibliography -- 432

SUB CODE: EC

SUBMITTED: 21May64

NO REF SOV: 015

OTHER: 000

Card 2/2 *md*

GOL'DENBERG, L.S.

Variant of the indirect psychotherapy method in monosymptomatic
hysteria. Vrach. delo no.10:149-150 O '61. (MIRA 14:12)

1. Gorodskoy psikhonevologicheskij dispanser, Krivoy bog.
(HYSTERIA) (PSYCHOTHERAPY)

GOL'DENBERG, Lev Moiseyevich; ZAYEMDNYI, A.M., otv. red ; YAKUBSON,
A.Kh., red.; ROMANOVA, S.F., tekhn. red

[Principles of pulse techniques] osnovy impul'snoi tekhniki.
Moskva, Sviaz'izdat, 1963. 399 p. (MLRA 16:7)
(Pulse techniques (Electronics))

1. GOLDENBERG, M.
2. USSR (600)
4. Cylinders
7. Restoration of cylinder heads for D-54, and a M-46 diesel motors, N. Tolstoyev.
MTS 13 no. 4, 1963.
9. Monthly List of Russian Accessions. Library of Congress. APRIL..... 1963, Uncl.