

827/18 23 1 1/77

24 (3)
AUTHOR:

Golant, V. Ye.

TITLE:

On the Connections Between the Characteristics of Super High Frequency and Direct Current in Gas

PERIODICAL:

Izvestiya Akademii nauk SSSR Seriya fizicheskaya 1977
Vol 25, Nr 6, pp 958 - 961 (USSR)

ABSTRACT:

In the present paper the conditions are to be formulated under which it is possible to set up the corresponding characteristics of direct- and super high-frequency current in gases. Under condition (1) that the frequency of the electric field is higher than the frequency of energy exchange between atoms and electrons the isotropic component of the velocity distribution of the electrons (2) is written down. This distribution function has form (3) for direct current. With equations (4) and (6) the conditions are given at which the functions of velocity distribution of electrons agree for direct- and alternating field. The comparison of the conditions for the velocity distribution of electrons leads to equations (7) to (10) for the identity: electron energy. It is ascertained that the complicated character of these conditions (7) to (10) compared

Card 1/2

On the Connections Between the Characteristics of Super High-frequency and Direct Current in Gas SOV/14 27 11/81

with conditions (4) to (6) is connected with assisted and electron conduction and the diffusion of electrons in the electric field. In conclusion, the possibility of determining the data for super high frequency current from the results of an investigation of direct current within gas is shown and the critical field intensity for neon, argon, krypton, and xenon is computed in an example. These values are compared with experimental data in the four diagrams of figure 1. There is good agreement. There are 4 figures and 11 references, 10 of which are Soviet.

ASSOCIATION: Leningradskiy politekhnicheskoy institut im. M. I. Kalinina (Leningrad Polytechnic Institute) im. M. I. Kalinina

9.1300

77323
SOV/57-30-1-2/18

AUTHORS:

Golant, V. Ye., Zhilinskiy, A. P.

TITLE:

Propagation of Electromagnetic Waves in Waveguides Filled With Plasma

PERIODICAL:

Zhurnal tekhnicheskoy fiziki, 1960, Vol 30, Nr 1, pp 16-24 (USSR)

ABSTRACT:

Propagation of electromagnetic waves through waveguides filled with gaseous discharge plasma is utilized in constructions of ultrahigh frequency commutation devices and in plasma investigations. One would like, therefore, to establish a relationship between the propagation constant of these electromagnetic waves and the complex conductivity of plasma. This problem in the cases of real plasma must take into account the varying conductivity of plasma in the waveguide due to varying concentrations of electrons in the plasma. In the present paper, the authors investigate wave propagation through a uniform waveguide filled with plasma homogeneous along the axis of the waveguide. Waveguide boundaries and plasma conductivity are then independent of the

Card 1,16

Propagation of Electromagnetic Waves in
Waveguides Filled With Plasma77323
837/57-30-1-2/18

longitudinal waveguide coordinates. Method used is analogous to those used by Slater, and by Sal and Walker (see ref). The authors started from Maxwell's equations:

$$\left. \begin{aligned} \operatorname{rot} \mathbf{E}_t - \mu_0 \frac{\partial \mathbf{H}_t}{\partial t} &= 0; \operatorname{div} \mathbf{H}_t = 0; \\ \operatorname{rot} \mathbf{H}_t - \epsilon_0 \frac{\partial \mathbf{E}_t}{\partial t} &= \mathbf{i}_t; \epsilon_0 \operatorname{div} \mathbf{E}_t = \rho_t; \mathbf{i}_t = \sigma \mathbf{E}_t. \end{aligned} \right\} \quad (1)$$

where \mathbf{E}_t and \mathbf{H}_t are strength of the electric and magnetic fields; \mathbf{i}_t is current density; ρ_t = instantaneous value of the space charge density; σ is conductivity of the medium; ϵ_0 and μ_0 are dielectric and magnetic permeability. Using the usual boundary conditions on the infinitely conducting wall, splitting the fields into space and time components, the authors proceed to define transverse components of the field \mathbf{E}_\perp and \mathbf{H}_\perp , and the longi-

Propagation of Electromagnetic Waves in
Waveguides Filled with Plasma

77323
87/87-30-2-3.16

parallel components E_z and H_z . Introducing ortho-
gonal transverse components E_x and H_x of the normal
modes existing in the absence of plasma, one rep-
resents the transverse field by:

$$E_x = \sum a_n E_n; H_x = \sum b_n H_n. \quad (8)$$

The equations are obtained in the usual way as:

$$a_n(G_n^2 - \gamma^2) = \frac{1}{\rho_n} \int \mathbf{E}_n \cdot \mathbf{E}_x dF + \frac{\gamma}{\rho_n} \int \mathbf{E}_n \cdot \mathbf{E}_z dF \quad (14)$$

$$b_n(G_n^2 - \gamma^2) = \frac{\gamma}{\rho_n} \int \mathbf{E}_n \cdot \mathbf{E}_z dF + \frac{1}{\rho_n} \int \mathbf{E}_n \cdot \mathbf{H}_x dF. \quad (15)$$

where

ρ_n and γ_n are the wave number and cutoff :

Propagation of Electromagnetic Waves in
Waveguides Filled With Plasma

1977
GPO: 7-3-1-8, 27

E_{\perp} is the transverse electric field, E_{\parallel} and the E_{\perp} 's are related by means of the following equation:

$$E_{\parallel} = \sum_k b_k E_{\perp k} \quad (16)$$

where ω is the field frequency. To solve (14) and (15), the authors assume σ to be proportional to a small parameter, and expand the coefficients and the propagation constant according to:

$$a_k = \sum_j a_{kj}, \quad b_k = \sum_j b_{kj}, \quad \gamma = \sum_j \gamma_j, \quad E = \sum_j E_j \quad (17)$$

They use perturbation theory and consider the a_{kj} 's to the first approximation and the γ_j 's to the second one. When a plane wave is incident,

Continued

Preparation of Elliptic waveguide
 Waveguides Filled with Dielectric

Equation (1) is valid for
 Elliptic waveguide

The general dispersion equation is then:

$$\epsilon_0 \epsilon_1 \beta^2 - \epsilon_2 \beta^2 = \epsilon_3 \beta^2 \quad (10)$$

must now contain both real and complex parts, due to the complex permittivity constant:

$$\epsilon_3 = \epsilon_3' + j\epsilon_3'' \quad (11)$$

which causes a phase shift $\Delta \beta = \beta - \beta_0$ and damping in the waveguide. In the limit of zero loss the terms are:

$$\epsilon_3 = \epsilon_3' + j\epsilon_3'' \quad (12)$$

$$\epsilon_3 = \epsilon_3' + j\epsilon_3'' \quad (13)$$

Card 5, 11

Propagation of Electrostatic Waves in
Wavelengths Field with Plasma

1963
Sov. J. Plasma Phys. 1-1-1963

waves in a plasma with TE waves and the TM waves. The authors discuss the case when the frequency of electrostatic waves with wave number k is less than the plasma frequency. They also discuss the possibility that the plasma is excited through the waveguide by means of "diode" tubes. One could try to develop relations for scattered fields in the waveguide with the tube, not within the plasma. However, this problem often does not allow exact solutions, and in the case of small tube thickness one can again analyze its contribution in the phase shift and damping by means of the perturbation theory. Finally, the authors calculated the cylindrically symmetrical case. The geometry of the problem is given in Fig. 1.

Fig. 1

Diagram of Electrostatic Wires in
Weymouth Filter Wire Design

Fig. 2
SAC: W-31-1-1-1-1

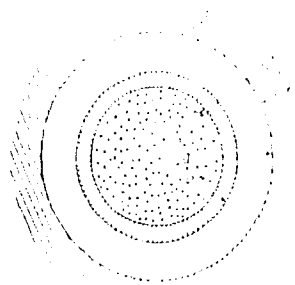

Fig. 2 shows a cross-section of wire which is filled with
plasma: (1) wire; (2) wall; (3) plasma; (4) plasma.

Fig. 2

Interpretation of the results of the experiment...
Wave function $\Psi(x, t)$...

The probability density $P(x, t) = |\Psi(x, t)|^2$ is...
The wave function $\Psi(x, t)$ is a function of position x and time t .

$$E_1 = E_2 = \dots = E_n = \dots = E_{\infty} \quad (52)$$

where $\rho(x, t)$ is the probability density...
The wave function $\Psi(x, t)$ is a function of position x and time t .

$$\rho(x, t) = |\Psi(x, t)|^2 \quad (53)$$

The wave function $\Psi(x, t)$ is a function of position x and time t .

Department of Mathematics
University of Michigan

Ann Arbor, Michigan

$$n = \text{const for } r \rightarrow 0 \quad (54)$$

and the function $\psi(r)$ is determined by the boundary conditions

$$\psi(0) = 0, \quad \psi(\infty) = 0 \quad (55)$$

where $\psi(r)$ is Bessel function of order n . The asymptotic behavior of the solution of the differential equation (54) for large r is given by the Bessel function of order n . The asymptotic behavior of the solution of the differential equation (54) for small r is given by the Bessel function of order n . The asymptotic behavior of the solution of the differential equation (54) for large r is given by the Bessel function of order n . The asymptotic behavior of the solution of the differential equation (54) for small r is given by the Bessel function of order n .

and by the

Preparation of Electrochromic Films in
Way of the MIP-1 With the

Yield
000 (1) (1) (1) (1)

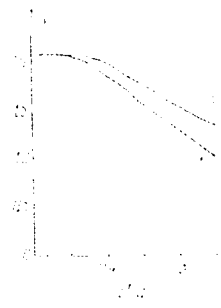

Fig. 2. (O) n_{20} ; (□) n_{20} (100% yield).

000 (1) (1)

Investigation of Electromagnetic Waves in
Waveguide with Thin Plates

Y. G. G.
S. M. P.

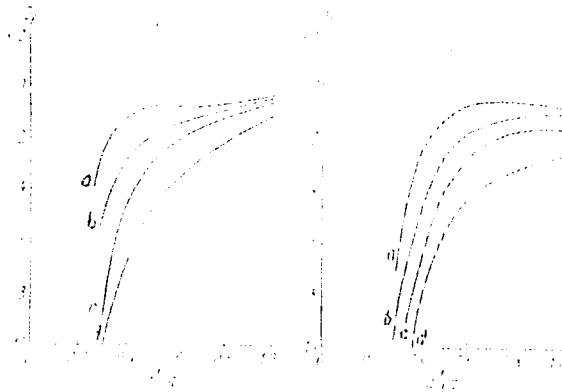

Fig. 1. (1) $\epsilon = 1$; (2) $\epsilon = 1.5$; (3) $\epsilon = 2$; (4) $\epsilon = 3$.
(a) $\lambda = 0.1$; (b) $\lambda = 0.2$; (c) $\lambda = 0.3$; (d) $\lambda = 0.4$.

© 1985 J.

Propagation of Electromagnetic Waves in
Waveguides Filled With Plasma

TTB:G
307/37-38-1-2/18

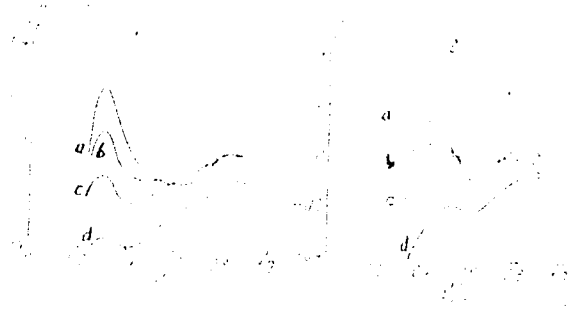

Fig. 4. (1) $\epsilon = \text{const}$; (2) $n = n_p(1 - \frac{\omega_p^2}{\omega^2})$.
 (a) $\frac{\omega}{\omega_p} \lambda = 0.15$; (b) $\frac{\omega}{\omega_p} \lambda = 0.30$; (c) $\frac{\omega}{\omega_p} \lambda = 0.45$; (d) $\frac{\omega}{\omega_p} \lambda = 0.60$.
 (1) $\frac{\omega}{\omega_p} \lambda = 0.15$; (2) $\frac{\omega}{\omega_p} \lambda = 0.30$; (3) $\frac{\omega}{\omega_p} \lambda = 0.45$; (4) $\frac{\omega}{\omega_p} \lambda = 0.60$.
 The coefficient B_{eff} calculated for $\frac{\omega}{\omega_p} \lambda = 0.15$.

Card 13, 1.

Propagation of Electromagnetic Waves in
Waveguides Filled With Plasma

77385
DDI/ST-3 -1-2/18

$$k_z^2 = \omega^2 \left(\frac{1}{c^2} - \frac{1}{v_{ph}^2} \right) - k_x^2 - k_y^2 \quad (56)$$

where v_{ph} = electron plasma velocity frequency,
 ω_{pe} = plasma frequency.

$$v_{ph}^2 = \frac{ce^2}{\epsilon_0 m} \quad (57)$$

e and m = charge and mass of electron.

Card 14/16

Proprietor: E.I. du Pont de Nemours & Co.
 Washington, D.C. 20535

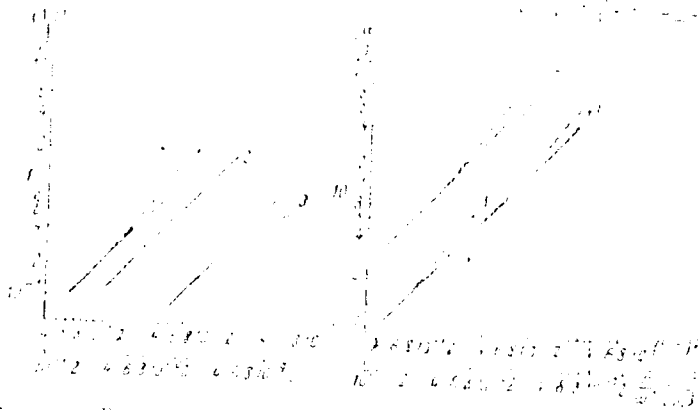

Fig. 1. Frequency response of the system. The curves show the relationship between the input and output signals. The curves are plotted for different values of the parameter λ . The curves are labeled (1) and (2). The curves show that the system is linear and that the output signal is proportional to the input signal.

Card 1, 1

Fig. 1. Illustration of the frequency response of the system. The curves show the relationship between the input and output signals. The curves are plotted for different values of the parameter λ . The curves are labeled (1) and (2). The curves show that the system is linear and that the output signal is proportional to the input signal.

GOLANT, V. Ye.; ZHILINSKIY, A. P.

Experimental investigation of the diffusion decay of plasma in
a magnetic field. Zhur. tekhn. fiz. 30 no.7:745-755 J1 '60.
(MIRA 13:8)

1. Leningradskiy politekhnicheskii Institut Im. M. I. Kalinina.
(Plasma (Ionized gases)) (Magnetic fields)

3/05/60/0*0/006/001/019
30*0/B020

AUTHOR:

Golan, V. Ye

TITLE:

Diffusion of Charged Particles¹⁹ Across a Magnetic Field in a
Three-component Plasma 11

PERIODICAL:

Zhurnal tekhnicheskoy fiziki, 1960, Vol. 30, No. 8,
pp. 881-892

TEXT: By way of introduction, several papers are mentioned including such by I. Ye. Tamm (Ref. 3), Ye. S. Fraikin (Ref. 4), and S. I. Braginskii (Refs. 5, 6), who had studied transport processes in completely ionized two-component plasmas. The present paper deals with the motion of charged particles under the action of concentration and temperature gradients in a plasma consisting of electrons, ions, and neutral atoms. In the first two sections the author examines the oriented motion of electrons and ions across a magnetic field, and derives formulas (27) and (28) for the respective fluxes. It is assumed in this connection that the concentration and temperature gradients as well as the electric field be sufficiently small, so that the distribution functions of electrons and ions can be

Card 1/3

✓

Diffusion of Charged Particles Across a Magnetic Field in a Three-component Plasma S/057/5C/030/008/001/019
B019/B060

represented as sums of undisturbed isotropic components and small oriented ones. The third section studies the bipolar diffusion of electrons and ions across the magnetic field. Here, the author obtains equations (48) and (49) for the electric field strength and the bipolar flux of particles in the direction of the gradients. The simplified formula (54) is derived for (49). The preceding formulas were all obtained on the assumption of the electron-ion collisions bearing no influence on ion motion. It was further assumed for the collision frequency of electrons and ions with neutral particles to be independent of velocity. Finally, the author studies the diffusion of electrons and ions across a strong magnetic field. Collisions of ions, electrons, and neutral atoms are considered here, and an approximation method developed by Braginskii (Ref. 6) is applied. A Maxwellian velocity distribution of neutral atoms is assumed in this connection. Formula (67) is obtained for the electric field strength in bipolar diffusion, and (68) for the bipolar flux of charged particles in the direction of the concentration and temperature gradients. The author finally thanks B. P. Konstantinov, Academician of the AS USSR, and G. A. Grinberg, Corresponding Member, for their discussion of the above-mentioned problems and for their valuable advice, as well as A. Ya. Chernyak

Card 2/3

✓C

ANISIMOV, A.I.; VINOGRADOV, N.I.; GOLANT, V.Ye.; KONSTANTINOV, B.P.

Method for investigating the spatial distribution of electrons in plasma.
Zhur. tekhn. fiz. 30 no.9:1009-1018 S '60. (MIRA 13:11)

1. Fiziko-tekhnicheskiy institut AN SSSR, Leningrad.
(Electrons) (Plasma (Ionized gases))

84559

S/057/60/030/011/002/009
B006/B054

10.8000/42507 only
24.2120

AUTHOR: Golant, V. Ye

TITLE: Superhigh-frequency Methods of Plasma Research 21

PERIODICAL: Zhurnal tekhnicheskoy fiziki, 1960, Vol 30, No. 11.
pp. 1265-1320

TEXT: The author gives a detailed review of the "active" methods of plasma examination in the superhigh-frequency range. Superhigh-frequency methods are particularly suited for studying the elementary processes of the interaction of electrons with atoms and ions, of the plasma disintegration of glow, arc, and high-frequency discharges, of high-temperature effects, and of radiation phenomena. The "active" methods supply data on the plasma characteristics and the relationship between the characteristics and conductivity. Section 1 of the paper gives a detailed review of papers on plasma conductivity in superhigh-frequency fields. The active and reactive components of plasma conductivity proved to be dependent on the electron concentration and the electron collision frequency. By measuring the conductivity components it is, thus, possible to determine

84559

Superhigh-frequency Methods of Plasma Research S/057/60/030/011/002/009
B006/E054

the plasma concentration, and to obtain data on interparticle collisions. If the velocity dependence of the collision frequency of electrons with heavy particles is known, the mean electron energy (electron temperature) can be estimated by measuring conductivity. If plasma in a strong magnetic field is subject to spatial dispersion, there is a direct relationship between the conductivity tensor and the electron temperature. This relationship may be used for high-temperature plasma research. Section 6 gives a discussion of the results of papers dealing with the effect of spatial dispersion on plasma conductivity. The superhigh-frequency methods of plasma examination mainly differ by the method of field generation in the plasma space. The methods can be classified accordingly: If the plasma to be examined is within the volume resonators, resonator method; within waveguides, waveguide method; when probing the plasma in a space free from high-frequency apparatus, method of free space. The theoretical principles of these methods and their applications are described in sections 2, 3, and 5. When studying plasma disintegration by the resonator and waveguide methods, the superhigh frequency field is used in a number of cases, not only to determine the plasma characteristic but also to heat the plasma. This makes it possible to determine the energy dependence of the quantities characterizing the electron collisions. Section 4 of the paper

84559

Superhigh-frequency Methods of Plasma Research S/057/60/030/011/002/009
B006/B054

describes the use of a superhigh frequency field for plasma heating during its investigation by the resonator or the waveguide method. In detail, the sections contain: section 1: plasma conductivity in a superhigh-frequency field (conductivity in a weak field; conditions for small field effects on plasma; conductivity in the presence of a constant magnetic field); section 2: resonator method (parameters of a spatial resonator filled with plasma; determination of electron concentration in plasma; determination of the electron collision frequency; experimental technique; results of the method); section 3: waveguide method (propagation of waves along a waveguide filled with plasma; applications of the method; experimental technique; results of the method); section 4: use of electron gas heated by a high-frequency field for plasma examination (heating of electron gases in a high-frequency field; use of high-frequency heating of electron gas to investigate a disintegrating plasma); section 5: probing of plasma with oriented waves (method of free space) (propagation of electromagnetic waves through plasma; homogeneous isotropic plasma; propagation along a plane layer of inhomogeneous plasma; reflection of waves from the layer with growing electron concentration; reflection of waves from a thin plasma layer; homogeneous plasma in a magnetic field; investigation by means of waves penetrating the plasma; investigation by means

Card 3/4

Superhigh-frequency Methods of Plasma Research 84559
S/087/60/040/011/002/003
B006/2054

of waves reflected from the plasma; determination of the frequency of electromagnetic waves at the critical density at which the reflection coefficient strongly increases); and section 6: the use of spatial dispersion in the superhigh frequency range to investigate high-temperature plasma. There are 22 figures, 3 tables, and 96 references: 32 Soviet, 47 US, 5 Swiss, 2 Swedish, 1 Czechoslovakian, 2 British, 3 German, 1 Italian, and 3 Australian.

ASSOCIATION: Fiziko tekhnicheskii institut AN SSSR, Leningrad
(Institute of Physics and Technology of the AS USSR,
Leningrad)

SUBMITTED: July 8, 1960

S/057/60/030/012/001/011
3019/3056

26.2311
AUTHORS:

Afrosimov, V. V., Glukhikh, V. A., Golant, V. Ye.,
Zaydel', A. N., Komar, Ye. G., Konstantinov, B. P.,
Malyshev, G. M., Malyshev, I. P., Monastov, N. A.,
Stolov, A. M., Fedorenko, N. V.

TITLE: Plasma Studies With "Alfa" Research Installation

PERIODICAL: Zhurnal tekhnicheskoy fiziki, 1960, Vol. 30, No. 12,
pp. 1381 - 1393

TEXT: A research installation for producing high power pulsed discharges in a toroidal chamber with an average diameter of 3.2 m and an inner cross-section diameter of 1 m is described. The chamber is filled with hydrogen, and discharge is obtained at a pressure of about $2 \cdot 10^{-4}$ mm Hg, and with an external magnetic field of 180 G. Discharges are produced by 2-3 msec electric pulses coming from a capacitor battery capable of storing $1.5 \cdot 10^6$ joules of energy. The entire installation is shown in a photograph, and is schematically represented in Fig. 2

87454

Plasma Studies With "Alfa" Research
Installation

S/057/60/030/012/001/011
B019/B055

The electric and magnetic characteristics of a plasma discharge are described in detail, after which microwave studies, spectrum analyses, and studies of the atomic flux emitted by the plasma are discussed. The experiments hitherto carried out on "Alfa" show that the production and character of a discharge do not correspond to the general conceptions of a selfcontracting quasisteady discharge. The authors formed this opinion owing to the lack of a long plasma column, which follows from measurements of the electric and magnetic characteristics, from microwave studies, from the existence of a large azimuthal current, from the asymmetry of discharge, from the occurrence of oscillations therein, and from a considerable inhomogeneity of plasma. Besides there is an inhomogeneous hydrogen-ion distribution, which is indicated by a large quantity of protons with energies exceeding 10 kev. An explanation of these effects is not possible as yet. There are 8 figures and 23 references: 13 Soviet, 3 Swedish, and 6 US.

Plasma Studies With "Al'fa" Research
Installation

S/057/60/030/012/001/011
E019/E055

ASSOCIATION: Fiziko-tekhnicheskiy institut AN SSSR (Institute of
Physics and Technology of the AS USSR). Nauchno-
issledovatel'skiy institut elektrofizicheskoy apparatury
(Scientific Research Institute of Electrophysical
Apparatus)

SUBMITTED: July 15, 1960

X

37151

S/057/60/03C/012/001/011
B019/3056

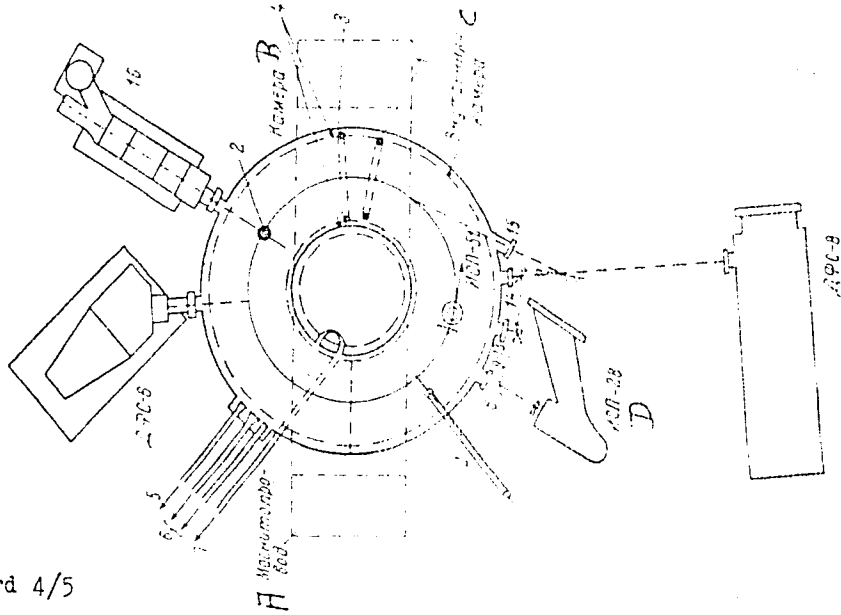

Fig. 2. Схема функционального устройства.

Sheet

3/05/59/010/12/001/01
3070/2056

Legend to Fig. 2. 2) Rogovskiy girddie; 3) Coil for measuring the mag-
netic flux passing through the cross section; 4) Coil for measuring
the magnetic field between the two magnets; 5), 6), and 7) are
emitters of millimeter and centimeter waves. 8) Instrument for study-
ing the atomic flux. A) Magnetic conductor; B) Chamber; C) Inner
chamber

Card 5/5

9.9845
26.2311

1.024
S/007/00/010/000/011
B019/B056

AUTHORS: Anoshkin, V. A., Golant, V. Ye., Konstantinov, E. P.,
Poloskin, B. P., and Shcherbinin, O. N.

TITLE: Microwave Studies of Plasma With "Alfa" Research
Installation

PERIODICAL: Zhurnal tekhnicheskoy fiziki, 1960, Vol. 30, No. 12,
pp. 1447 - 1455

TEXT: The authors studied plasma in the research installation "Alfa" with 3-cm and 8-mm waves. Fig.1 shows a block diagram of the measuring arrangement. The studies were carried out at a voltage of 10 and 15 kv at the discharge capacitors (capacity 4600 microfarads), field strengths of the longitudinal field of 180, 360, 540, and 720 ce, and pressures of the hydrogen atmosphere of $2 \cdot 10^{-3}$, 10^{-3} , and $2 \cdot 10^{-4}$ mm Hg. The results concerning the reflection and the passage of radiowaves through plasma were discussed in detail on the basis of oscillograms and diagrams. From the results obtained by the experiments described, the

87461

Microwave Studies of Plasma With "Alfa"
Research Installation

S/057/80/030/012/006/011
B019/B056

authors conclude that the collective motion of plasma has a complex character. The plasma effects irregular vibrations with frequencies not exceeding 10^5 cps. It first occurs near the chamber with a concentration of 10^{12} cm^{-3} , and later more in the interior. Under the conditions investigated, no continuous production of plasma over the entire cross-section was observed. It was further found that near the chamber wall there exists a region, in which the electron concentration exceeds the original concentration ($4 \cdot 10^{12}$ cm^{-3}). At pressures of more than 10^{-3} mm Hg and at certain values of the magnetic longitudinal field the breakup of plasma has an ordered character. The breakup has a duration of about 0.5 to 2 microseconds. There are 10 figures and 5 Soviet references.

Microwave Studies of Plasma With "Al'fa"
Research Installation

S/057/60/030/012/008/011
B019/B056

ASSOCIATION: Fiziko-tehnicheskiy institut AN SSSR (Institute of
Physics and Technology of the AS USSR). Nauchno-
issledovatel'skiy institut elektrofizicheskoy apparatury
(Scientific Research Institute of Electrophysical
Apparatus)

SUBMITTED: July 15, 1960

Card 3/5

87461
S/057/60/030/012/009/011
B019/B056

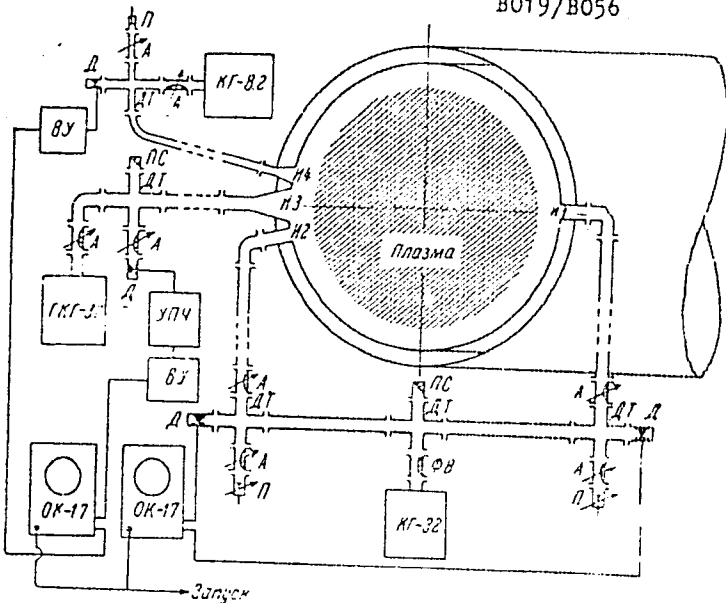

Card 4/5

2003

9,1300 (also 1532)
24,2120 (1049, 1482, 1502)

S/057/61/031/001/002/017
B100/3300

AUTHORS: Gelant, V. Ye., Zhilinsky, A. P., Kravchikov, M. V.,
and Nekrutkina, G. P.

TITLE: Propagation of centimetric waves by a plasma filled
with the plasma of a positive column discharge

PERIODICAL: Zhurnal tekhnicheskoy fiziki, v. 31, no. 1, 1961, 55-62

TEXT: The studies which are the subject of the present report were carried out with a plasma produced in helium at pressures from 0.05 to 10 mm Hg. The wave constant and the velocity of homogeneous waveguides filled with plasma were determined for 3-cm and 10-cm waves. For the 3-cm wave range, two experimental arrangements were used, while one was used for the 10-cm wave range. Fig. 1 shows a summary of these arrangements. The phase shift in the waveguide was measured with a phase bridge, and damping was determined by a substitution method. Results are given in Figs. 2, 3. In evaluating the experimental results, a comparison is made with the results of a theoretical investigation by Gelant et al. (Ref. 11). The relations

Card 1/2

Propagation of centimeter waves ...

9/037/61/011/001/008/017
 8104/0001

✓

$$\Delta \alpha = \frac{1}{2} \frac{\partial \alpha}{\partial F} \frac{\partial F}{\partial n} \left(\frac{\partial n}{\partial F} \right) \quad (2)$$

$$\Delta \alpha = \frac{1}{2} \frac{\partial \alpha}{\partial F} \Delta F$$

were obtained in first perturbation-theoretical approximation for the damping and phase constants. λ_w and λ are the wavelengths in the waveguide and in the free space; $Z = \sqrt{\epsilon/\mu_0}$ is the wave impedance of the free space; n is the electron concentration; F is the plasma cross section; A_{OP} is a form factor; σ_{11} and σ_{12} are the reactive and active components of the specific high-frequency conductance of the plasma per electron. The relations

$$\sigma_{11} = \frac{W}{V} = \frac{2\pi F}{V} \frac{A_{OP}}{A_{OP}} \frac{1}{Z} \quad (3)$$

$$\Delta \alpha / \Delta F = \sigma_{12} / \sigma_{11}$$

3063

Propagation of centimetric waves ...

S/057/61/031/001/008/017
B104/B204

are obtained, which establish a connection between the components of conductance and the discharge current. These relations permit the determination of 4β and $\Delta\alpha$ if the electron distribution over the plasma cross section determined by the form factor A_{oP} , the longitudinal field in the positive column, and the components of conductance are known. A_{oP} was determined previously on the assumption of a diffuse electron distribution in the positive column. Furthermore, the relations

$$\frac{\sigma_{1i}}{\sigma_{1n}} = \frac{(\omega/\nu)}{1 + (\omega/\nu)^2} \quad \text{and} \quad \sigma_{1i}/\sigma_{1n} = \omega/\nu \quad (6) \quad \text{were substituted}$$

in formulas (5); σ_{1n} is the specific conductance in a constant field per electron. As follows from the comparisons shown in Figs. 3, 4, and 5, the deviation never attains more than 30%. The ratio $\Delta\alpha/\Delta\alpha$ shows better agreement with experimental values. This is explained by the fact that this ratio is independent of the spatial electron distribution and the strength of the longitudinal field. There are 7 figures and 17 references:

Card 3/7

Propagation of centimetric waves ...

S/057/61/03/001/008/017
B104, B104

8 Soviet-bloc and 8 non-Soviet-bloc.

ASSOCIATION: Leningradskiy politekhnicheskii institut im. M. I. Kalinina
(Leningrad Polytechnic Institute imeni M. I. Kalinin)

SUBMITTED: July 13, 1960

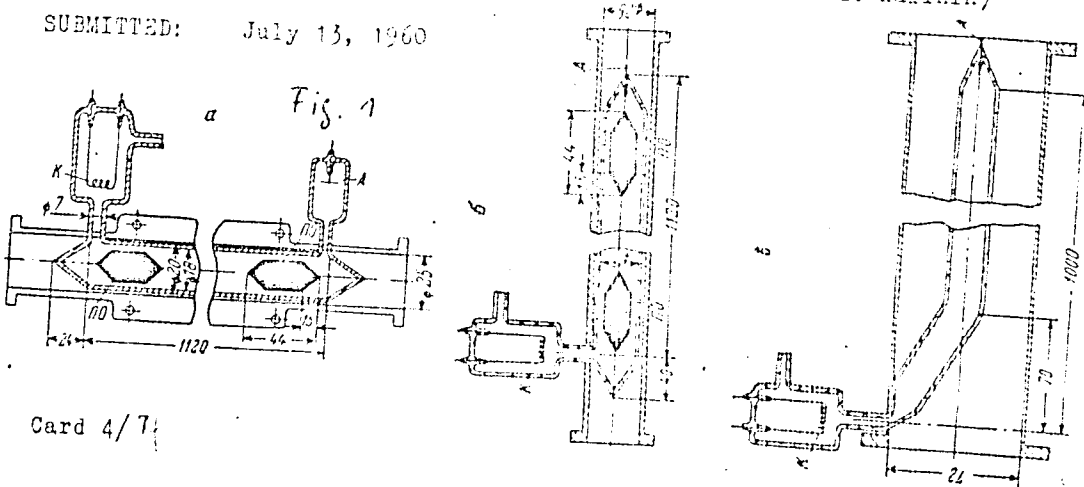

Card 4/7:

Preparation of plasma

844
570 001 001 001 001 001
001 001

The plasma is prepared by the ionization of a gas mixture at low pressure and low temperature. The ionization is not done by the general method of the discharge, but by the presence of a high frequency field. The ionization is done by the presence of a high frequency field.

$$\int_{\text{plasma}} \frac{1}{\epsilon_0} \nabla \cdot \mathbf{E} = \rho_{\text{plasma}} \quad \text{where } \mathbf{E} = -\nabla \phi - \dot{\mathbf{A}}$$

The plasma is prepared by the ionization of a gas mixture at low pressure and low temperature. The ionization is not done by the general method of the discharge, but by the presence of a high frequency field. The ionization is done by the presence of a high frequency field. E_{plasma} the field strength of the ionization field, B_{plasma} the strength of the high frequency field, ρ_{plasma} the plasma density, ϵ_0 the permittivity of free space, $\nabla \cdot \mathbf{E}$ the divergence of the electric field, ρ_{plasma} the plasma density. A similar expression is given for the case of the discharge current produced by applying the high frequency field. From these results it may be seen that the discharge is a discharge with a positive column and a negative column.

Card 2/4

20604

Propagation of centimetric waves ...

S/057/61/031/001/009/017
SIC4/BEC2

temperature, but leads to a decrease of the longitudinal constant field and to an increase of the concentration of charged particles. The authors state that in first perturbation-theoretical approximation, the wave propagation constant changes proportional to the electron concentration, when a plasma is introduced into a waveguide. The changes in the phase constant $\Delta\beta^*$ and the damping constant $\Delta\alpha^*$ in the presence of a high-frequency field are determined in first perturbation-theoretical approximation by the relation

$$k = \Delta\alpha^*/\Delta\alpha = \Delta\beta^*/\Delta\beta \quad (7),$$

where $\Delta\alpha^*$ and $\Delta\beta^*$ were determined at a given high-frequency field strength, and $\Delta\alpha$ and $\Delta\beta$ at an infinitely low high-frequency field strength. The experimental determination of the dependence of the phase constant upon field strength was carried out by means of the facilities described in the previous paper (Ref. 1). The results obtained are graphically represented in Figs. 2-5. As may be seen, deviations between theoretical and experimental values for helium are below 15%, and for argon below 30%. The causes for these deviations are said to be

Card 3/7

20664

Propagation of centimetric waves ...

5/007/6/001/001/000/017
B104/B204

J

changes in the flux of force, inhomogeneities of the field, inexact determination of field longitudinal components, and of conductivities. Finally, the use of nonlinear effects for the stabilization of the power of super-high frequencies occurring in a waveguide filled with a plasma is discussed. Fig. 9 shows the scheme of such a stabilizer. This scheme represents a power divider made from three-decibel slit-bridges. The superhigh-frequency signal is divided between the input channels, and the ratio of the power-flows in the various output channels is determined from the phase difference between the waves passing through the upper and lower waveguides. If a waveguide contains a gas discharge and phase shifter, a possibility offers itself in that power range in which nonlinear interaction effects of the plasma with the superhigh-frequency field occur, of stabilizing the power flow at the output of the power divider. There are 9 figures and 8 references: 6 Soviet-bloc.

ASSOCIATION: Leningradskiy politekhnicheskii institut im. M. I. Kalinina
(Leningrad Polytechnic Institute imeni M. I. Kalinin)

SUBMITTED: July 13, 1960

Card 4/71

2105

3/03/76:03:007/018/02
3*08/1.09

9,4120

AUTHORS: Golant, V. Ya., Orlov, A. I., Fakhomov, L. P.

TITLE: Production of a high-density plasma by a hot-cathode discharge in a magnetic field

PERIODICAL: Zhurnal tekhicheskoy fiziki, v. 31, no. 7, 1961, 797-801

TEXT: The authors present the results of an investigation of a hot-cathode discharge in a magnetic field. In such a discharge with a current density of over 10 A/cm^2 in an inhomogeneous magnetic field ($H_{\text{in}} > 1 \text{ kG}$) magnetic field strength in the region under examination, H_0 - magnetic field strength near the cathode, a plasma concentration of over 10^{14} cm^{-3} may be attained theoretically. It was the aim of the present investigation to determine the concentration of charged particles in such a plasma. The emitting area on the conical or ring-shaped cathode was 1 cm^2 , its temperature over 2000°C . The distance between the tungsten anode and cathode was 1 cm . The measurements were made in both a homogeneous and an inhomogeneous magnetic field.

J

25025

3 100 71/03: 017/10/02:
3'08 291

Plasma in a magnetic field,

with fields up to 200 gauss. The discharge was kept in a hydrogen
at a pressure of 10^{-4} mm. at a mixture of 1000 V and 100 volts. In a
homogeneous field, the discharge had the shape of a cylinder with a radius
of 1 mm; at a current of $I = 10^{-2}$ A was 10^{-2} cm. In the case
of an inhomogeneous magnetic field, the plasma cord was found to be cylin-
drical in shape, however, with variable thickness, due to an azimuthal
distribution of the particles in the inhomogeneous field. In a homogeneous
field of up to 200 gauss, the concentration of the plasma as measured
by a probe gave a number, expressed 10^{14} cm $^{-3}$. Finally, the authors thank
V. V. Rebnestvenskiy for the optical measurements, V. V. Rebnestvenskiy for the
measurements of the backscattered radiation, and
V. F. Konstantinov for discussion. There are 4 figures and
4 references. 2 Soviet-bloc and 2 non-Soviet-bloc

AGORATION: Fiziko-tekhnicheskii institut im. A. F. Ioffe at USSR
Leninrad (Institute of Physics and Technology imeni
A. F. Ioffe AS USSR Leninrad)

Car 1/7

S/057/62/032/001/017/018
B111/B102

26.1410

AUTHORS: Golant, V. Ye., and Zhilinskiy, A. P.

TITLE: Experimental study of the diffusion decomposition of a plasma
in a magnetic field. II

PERIODICAL: Zhurnal tekhnicheskoy fiziki, v. 32, no. 1, 1962, 127 - 129

TEXT: The authors measured the dependence of the diffusion rate in a helium plasma on pressure (0.02 - 0.8 mm Hg) and on the longitudinal magnetic field (up to 2400 oe). The measurements were made in pulsed operation (20 cps, pulse duration 1-2 μ sec); in the intervals between the pulses the plasma electron concentration was measured by the waveguide method. The diffusion coefficients measured are in good agreement with a formula calculated in Ref. 1 (V. Ye. Golant and A. F. Zhilinskiy, ZhTF, 30, 745, 1960). It is found that the transverse escape rate of charged particles in the magnetic field is considerably higher than the diffusion rate calculated from collisions between electrons and atoms. The plasma decomposition constant was found to depend practically linearly both on the magnetic field and on pressure. The orbital velocity of charged particles along the
Card 1/2

GOLANT, V.Ye.; ZHILINSKIY, A.P.

Diffusion decay of a plasma in a magnetic field. Part 3. Zhur.
tekh. fiz. 32 no.11:1313-1318 N '62. (MIRA 15:11)

1. Leningradskiy politekhnicheskii institut imeni M.I.Kalinina.
(Plasma (Ionized gases)) (Magnetic fields)

S/057/63/033/001/017
B125/B186

AUTHOR: Golant, V. Ye.

TITLE: The diffusion of charged plasma particles in a strong magnetic field which influences the particle collision

PERIODICAL: Zhurnal tekhnicheskoy fiziki, v. 33, no. 1, 1963, 3 - 15

TEXT: The diffusion currents of charged plasma particles across a strong magnetic field were investigated for different ratios between the Larmor radii of the particles and the Debye radius. The Coulomb field of the interaction between the particles is cut off at the Debye radius. The deformation of the screening region is neglected. For $r_d \ll \bar{r}_e$ the diffusion vector flux is given by

The diffusion of charged ...

S/057/63/033/001/001/017
B125/B186

$$\left. \begin{aligned} \Gamma_{a3} = -\frac{4}{3} D_{13} n_a n_3 Z_a \left(\ln \frac{r_0}{r_a} \right) \cdot \left[Z_a \frac{1}{n_a} \nabla n_a - Z_a \frac{1}{n_3} \nabla n_3 + \right. \\ \left. + \left(\frac{m_a Z_a - m_3 Z_3 + \frac{1}{2} m_a Z_a - \frac{1}{2} m_3 Z_3}{m_a + m_3} \right) \cdot \frac{1}{T} \nabla T \right]; \\ D_{a3} = \left[\frac{2\pi m_a m_3}{(m_a + m_3) T} \right]^{1/2} \frac{e^2 a^2}{H^2}; \quad r_0 = \begin{cases} r_c & \text{при } r_c \gg r_a \\ r_a & \text{при } r_a \gg r_c \end{cases} \end{aligned} \right\} \quad (6d),$$

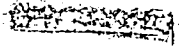

where n_a is the concentration of the particles of kind a , \vec{v}_a is the velocity, r_a is the radius vector, $\vec{R}_a = \vec{r}_a + \vec{\rho}_a$ the radius vector of the guiding center, $\rho_a = (m_a c / Z_a e \hbar) \cdot \sqrt{v_a / \hbar}$ the Larmor radius, m_a the mass of the particle, Z_a its charge, \hbar the unit vector in the direction of the magnetic field, ρ is the collision parameter, and T the temperature in energy units. The electron ion collisions lead to the diffusion vector flux

Card 2/4

The diffusion of charged ...

S/057/63/035/001/001/017
B125/B186

$$\Gamma_{i1} = Z_i \Gamma_{i2} = -D_{i1} n_i n_i Z_i \left(\frac{4}{3} \ln \frac{\bar{r}_e}{r_0} + \ln \frac{r_d}{\bar{r}_e} \cdot \ln \frac{v_e^2}{v_0^2} \right) \cdot \left[Z_i \frac{1}{n_i} \nabla n_i + \frac{1}{n_i} \nabla n_i + \left(1 - \frac{Z_i}{2}\right) \frac{1}{T} \nabla T \right]; \quad (69)$$

$$\frac{v_e^2}{v_0^2} = \frac{m_i}{m_e} \text{ or } \frac{(r_d \bar{r}_e)^{1/2}}{r_e} \text{ (the smaller of the two quantities)}$$

In both the regions $p > \bar{r}_e$ and $p < \bar{r}_e$, the electron-electron collisions produce zero fluxes. The collisions between ions of different kinds yield the flux (68). When $\bar{r}_d \gg \bar{r}_i$ the total diffusion vector flux for the three regions $p < \bar{r}_e$, $\bar{r}_e < p < \bar{r}_i$, $p > \bar{r}_i$ is given by

$$\Gamma_{i1} = Z_i \Gamma_{i2} = -D_{i1} n_i n_i Z_i \left\{ \left[\frac{4}{3} \ln \frac{\bar{r}_e}{r_0} + \frac{1}{2} \ln \frac{m_i}{m_e} \ln \frac{v_e^2}{v_0^2} + \ln \frac{r_d}{\bar{r}_e} \ln \frac{(r_d \bar{r}_e)^{1/2}}{r_e} \right] \cdot \left[Z_i \frac{1}{n_i} \nabla n_i + \frac{1}{n_i} \nabla n_i - \frac{1}{2} Z_i \frac{1}{T} \nabla T \right] + \left(\frac{4}{3} \ln \frac{\bar{r}_e}{r_0} + \frac{1}{2} \ln \frac{m_i}{m_e} \ln \frac{v_e^2}{v_0^2} \right) \frac{1}{T} \nabla T \right\}; \quad (70)$$

The diffusion of charged ...

S/057/63/033/001/001/017
B125/B186

$$\Gamma_{\pm 0} = -D_{\pm} n_{\pm} Z_{\pm} \left\{ \frac{1}{3} \ln \left(\frac{v_0}{v_0} \right) + \ln \left(\frac{v_0}{v_0} \right) \right\} \cdot \left[Z_{\pm} \frac{1}{n_{\pm}} \nabla n_{\pm} + \right. \\ \left. + \frac{1}{2} \left(\frac{m_1 Z_1 - m_2 Z_2}{m_1 + m_2} \right) \frac{1}{T} \nabla T \right] + \frac{1}{3} \ln \left(\frac{m_1 Z_1 - m_2 Z_2}{m_1 + m_2} \right) \frac{1}{T} \nabla T \quad (71)$$

Here the particles of the kinds "1" and "2" are ions. The present results are valid for Maxwell velocity distribution. For small longitudinal electron velocities and for $\left| \frac{v_0}{v_0} \right|$ significant change in the diffusion current may result from deviations from the Maxwell distribution. There are 4 figures.

ASSOCIATION: Fiziko-tekhnicheskiy institut AN SSSR im. A. F. Ioffe, Leningrad (Physicotechnical Institute AS USSR imeni A. F. Ioffe, Leningrad)

SUBMITTED: February 15, 1962

Card 4/4

ACCESSION NR: AT4025298

S/0000/63/000/000/0095/0103

AUTHORS: Anisimov, A. I.; Vinogradov, N. I.; Golant, V. Ye.

TITLE: Investigation of spatial distribution of the particles in a decaying plasma

SOURCE: Diagnostika plazmy* (Plasma diagnostics); sb. statey. Moscow, Gosatomizdat, 1963, 95-103

TOPIC TAGS: plasma atom distribution, plasma density, plasma decay, charged particle distribution, plasma instability

ABSTRACT: Curves showing the spatial distribution of charged particles in a decaying plasma in the concentration range 10^{12} -- 10^{13} cm^{-3} are obtained from previously reported experimental data (Zh. tekhn. fiz. v. 32, 197, 1962). It is shown that the procedure for the determination of the spatial distribution of the charged particles used in this research (Zh. tekhn. fiz. v. 30, 1009, 1960) can

Card 1/4

ACCESSION NR: AT4025298

be greatly improved in the case of a decaying plasma, because the charge-particle distribution remains practically the same at the later stages of the plasma decay. A theoretical procedure for processing the experimental data is derived on the basis of the geometrical-optics approximation, and the resultant curves are confirmed by data on the spatial distribution of the plasma glow, showing that the experimental results are in agreement with the theory of plasma decay. Orig. art. has: 5 figures and 7 formulas.

ASSOCIATION: None

SUBMITTED: 19Oct63

DATE ACQ: 16Apr64

ENCL: 02

SUB CODE: ME

NR REF SOV: 007

OTHER: 002

S/057/63/033/003/001/021
B104/B180

AUTHOR: Golant, V. Ye.

TITLE: Effect of collisions between equally charged particles
on plasma diffusion across a strong magnetic field

PERIODICAL: Zhurnal tekhnicheskoy fiziki, v. 33, no. 3, 1963, 257-262

TEXT: Plasma diffusion across a magnetic field is investigated taking account of the higher derivatives of concentration and the non-uniform electric field due to charge separation by the collisions. The magnetic field is assumed to be strong enough for ω the Larmor frequencies to be greater than ν the collision frequencies and r_L the Larmor radii much smaller than l the characteristic lengths. Then the concentration gradient and the field are small and the diffusion current can be given as a p/l expansion. Only the first non-vanishing terms of this expansion are considered. The electric field produced by the charge separation has a strength of $\sim T/e l$, and provides a bipolar diffusion mechanism in a totally ionized gas. If the ion Larmor radii are smaller than l the bipolar diffusion currents due to collisions of equal particles will be

Card 1/2

Effect of collisions between equally ...
negligible.

S/057/63/033/003/001/021
B104/B180

ASSOCIATION: Fiziko-tehnicheskij institut AN SSSR im. A. F. Ioffe,
Leningrad
(Physicotechnical Institute AS USSR imeni A. F. Ioffe,
Leningrad)

SUBMITTED: March 8, 1962

GOLANT, V.Ye.; DANILOV, G.P.; ZHILINSKIY, A.I.

Plasma decomposition in a toroidal magnetic field, Zhur.
tekh. fiz. 33 no.9:1603-1606, 1963. (MIRA 16411)

1. Leningradskiy politehnicheskiy institut imeni Kalinina.

GOLANT, V.Ye.; GRINBERG, G.A.

Solution of a nonlinear equation describing the decomposition of a plasma in a magnetic field, Zhur. tekhn. fiz. 33 no.9:1139-1141 S 163, (MIRA 16:11)

1. Fiziko-tekhnicheskoy institut AN SSSR imeni A.F. Ioffe, Leningrad.

ANISIMOV, A.I.; VINOGRADOV, N.I.; GOLANT, V.Ye.

Determining the coefficients of volume removal of electrons
by plasma break-up in oxygen. Zhur. tekh. fiz. 33 no.9:1141-
1143 S '63. (MIFA 16:11)

1. Fiziko-tekhnicheskii institut imeni A.F. Ioffe AN SSSR,
Leningrad.

ANISIMOV, A.I.; VINOGRADOV, N.I.; GOLANT, V.Ye.

Use of the resonator method in studying the break-up of a plasma
in a magnetic field. Zhur. tekhn. fiz. 33 no.11:1370-1377 N '63.
(MIRA 16:12)

1. Fiziko-tekhnicheskii institut imeni A.F.Ioffe, Leningrad.

GOLANT, V.Ye.

Diffusion of charged plasma particles in a magnetic field. Usp.
fiz. nauk 79 no.3:377-440 Mr '63. (MIRA 16:3)
(Diffusion) (Plasma (Ionized gases)) (Magnetic fields)

ACCESSION NR: AP4009923

S/0057/64/034/001/0077/0083

AUTHOR: Ganichev, A.A.; Golant, V.Ye.; Zhilinskiy, A.P.; Khotimskiy, B.Z.; Shilin, V.N.

TITLE: Investigation of the diffusion of charged particles in a decaying plasma in a magnetic field

SOURCE: Zhurnal tekhnicheskoy fiziki, v.34, no.1, 1964, 77-88

TOPIC TAGS: plasma, plasma decay, diffusion, charged particle diffusion, diffusion in magnetic field, ambipolar diffusion, helium plasma, helium plasma decay, helium ion diffusion

ABSTRACT: Previous measurements (V.Ye.Golant and A.P.Zhilinskiy, ZhTF, 32, 127, 1962) have shown an anomalously high rate of decay of plasma in a longitudinal magnetic field when the diameter of the discharge tube is small. In order to investigate this phenomenon, the decay of spectroscopically pure helium plasmas was observed in glass and quartz discharge tubes with diameters ranging from 0.4 to 6.6 cm. Longitudinal magnetic fields up to 6000 Oe were employed with the smaller discharge tubes, and fields as high as 1300 Oe were employed with the largest tube. The plasmas were formed by hot cathode pulse discharges in He at pressures from 0.05 to 1.5 mm Hg.

Card 1/3

ACC.NR: AP4009923

The decay was followed by observing the shift of the resonant frequency of a microwave resonant cavity surrounding part of the discharge tube. In some cases the change in the Q of the cavity was also followed in order to obtain information about electron collision rates. Wavelengths in the neighborhoods of 3 and 30 cm were employed. Transverse diffusion coefficients were calculated from the observed decay curves with the aid of suitable assumptions concerning the longitudinal diffusion. The transverse diffusion coefficients obtained for plasmas in discharge tubes with diameters of 4 cm or greater agreed well with theoretical values. Those for plasmas in smaller discharge tubes did not, the observed transverse diffusion coefficients being greater than the theoretical by a quantity that is roughly independent of the magnetic field. The following possible causes for this anomalous behavior are briefly discussed and rejected: impurities in the gas; enhanced electron temperatures; disturbance of the ambipolar diffusion mechanism by magnetic field inhomogeneities. The authors consider it most likely that an instability develops and gives rise to anomalous transverse diffusion. The excitation of oblique drift waves or ionic-acoustic waves, and the development of small scale flute instability are mentioned as possibilities. During the experiments it was noted that even a very small misalignment of the discharge tube with respect to the magnetic field would greatly increase the plasma decay rate. The diffusive decay of a plasma in a rec-

Card 2/3

ACC.NR: AP4009923

tangular discharge tube in an oblique magnetic field is treated theoretically. It is shown that when the angle between the discharge tube axis and the magnetic field lies between certain limits, the ambipolar diffusion mechanism is disturbed and the electrons diffuse primarily along the magnetic field while the ions diffuse mainly transversely to it. The relation between obliquity to the magnetic field and plasma decay rate calculated for a rectangular discharge tube accounts reasonably well for the effect observed with cylindrical tubes. "The authors express their deep gratitude to V.V.Bulanin, who participated in some of the experimental investigations. The authors are deeply grateful to O.P.Bochkova, in whose laboratory the spectrum analysis of the gas was conducted." Orig.art.has: 28 formulas, 8 figures and 2 tables.

ASSOCIATION: Leningradskiy politekhnicheskii institut im.M.I.Kalinina (Leningrad Polytechnic Institute)

SUBMITTED: 09Jul63

DATE ACQ: 10Feb64

ENCL: 00

SUB CODE: PH

NR REF SOV: 012

OTHER: 003

Card ^{3/3}

ACCESSION NR: AP4009924

S/0057/34/034/001/0089/0052

AUTHOR: Anisimov, A. I.; Budnikov, V. N.; Vinogradov, N. I.; Golant, V. Ye.

TITLE: On the reasons for anomalously rapid decay of a plasma in a magnetic field

SOURCE: Zhurnal tekhnicheskoy fiziki, v.34, no.1, 1934, 89-92

TOPIC TAGS: plasma, plasma decay, plasma decay in magnetic field, anomalous plasma decay, electron temperature, recombination, oblique drift waves, flute instability

ABSTRACT: Several experiments [Orig. art. cites 6 references] have shown that a weakly ionized plasma in a cylindrical container of small diameter in a longitudinal magnetic field decays more rapidly than can be accounted for by current diffusion theory. In order to determine whether this anomalous behavior may be due to enhanced electron temperature, the decay of helium plasmas in a 0.5 cm diameter glass discharge tube was observed at ambient temperatures of 300 and 500°K. The gas pressure was 0.1 mm Hg, and longitudinal magnetic fields up to 4800 Oe were employed. The plasma decay was followed by observing the shift in the resonant frequency of a cavity resonator enclosing a portion of the discharge tube. The intensity of the light emitted by the decaying plasma was monitored with a photomultiplier in order

Card 1/3

ACC.NR: AP4009924

to observe changes in the recombination rate. Raising the ambient temperature from 300 to 500°K produced a small increase in the plasma decay rate. The radiated light intensity was proportional to the square of the electron density and was independent of the magnetic field. The light intensity was greater by a factor 3 or 4 at 300° than at 500°. From these data and the roughly known temperature dependence of the recombination rate, it is concluded that the electron temperature could not exceed the ambient temperature by more than a factor 2.5. It is accordingly concluded that enhanced electron temperature cannot be responsible for the anomalous decay rate. That the rapid decay might be due to recombination is excluded by the fact that the decay rate increased with increasing ambient temperature, whereas the recombination rate decreased. It is inferred that the anomalously rapid decay of a plasma in a magnetic field is due to the development of instability. The excitation of oblique drift waves, and the development of small-scale flute instability due to rotation of the non-uniform plasma in the magnetic field are mentioned as possibilities. Orig.art.has: 1 formula and 3 figures.

2/3

Card

ACC.NR: AP4609924

ASSOCIATION: Fiziko-tekhnicheskiy institut im.A.F.Ioffe AN SSSR, Leningrad (Physi-
cal-Technical Institute, AN SSSR)

SUBMITTED: 18Jul63

DATE ACQ: 10Feb64

ENCL: 00

SUB CODE: PH

NR REF SOV: 009

OTHER: 004

Card 3/3

ACCESSION NR: AP4040294

S/0057/64/034/006/0953/0960

AUTHOR: Golant, V.Ye.; Krivosheyev, M.V.; Privalov, V.Ye.

TITLE: Investigation of a hot cathode discharge in a magnetic field

SOURCE: Zhurnal tekhnicheskoy fiziki, v.34, no.6, 1964, 953-960

TOPIC TAGS: plasma, gas discharge, discharge plasma, impulse discharge, ion density, argon plasma, plasma-magnetic field interaction

ABSTRACT: The charged particle density in a hot cathode argon discharge was investigated at pressures from 0.001 to 1 mm Hg and currents up to 25 A in the presence of a longitudinal magnetic field of 2500 Oe or less. A brief theoretical discussion is also given, based on the work of I.Langmuir and L.Tonks (Phys.Rev.33,954,1929; 34,876,1929), which leads to expressions for the ion density in the two limiting cases that the ion mean free path is long or short, respectively, compared with the dimensions of the apparatus. The discharge took place in a 6 cm diameter glass tube between a 4 cm diameter molybdenum anode and a directly heated spiral tungsten cathode located 20 cm from it. The emitting surface of the cathode was 0.5 cm². A 3 mm long 0.3 mm diameter molybdenum probe was provided on the axis of the tube to

Card 1/3

ACCESSION NR: AP4040294

measure the ion density. The charged particle density was also determined from the attenuation of microwaves, focused with elliptical reflectors. The ratio of the probe ion current to the ion density was determined from the microwave measurements at densities below the critical value. This ratio was assumed to remain constant at higher densities and was used to determine the ion density from the probe current. The apparatus was operated under steady state conditions at currents up to 2 A and was pulsed at higher currents. Preliminary experiments with He, A and Xe showed that, in agreement with the theory, the ion density increased with ion mass under otherwise similar conditions. The ion density was approximately proportional to the total current. For fixed current, the ion density increased with decreasing cathode temperature; this is a consequence of the increasing fraction of the cathode current carried by ions. In the absence of the magnetic field, the ion density for fixed current increased monotonically with the pressure. With the magnetic field present, the ion density reached a maximum at a pressure between 0.01 and 0.1 mm Hg and decreased at higher pressures. The pressure for maximum ion density increased with increasing magnetic field, and the decrease in density at higher pressures is ascribed to loss of ions to the walls by transverse diffusion. At 25 A and 2500 Oe the rising portion of the experimental ion density versus pressure curve agreed with the theo-

Card 2/3

ACCESSION NR: AP4040294

retical curve within about a factor of 2. This agreement can be considered satisfactory. For fixed current the ion density rose rapidly with increasing magnetic field. Ion densities of the order of 10^{15} cm^{-3} were attained, which correspond to a degree of ionization of several tenths. "In conclusion, the authors express their deep gratitude to V.A.Yermakov, who participated in some of these investigations." Orig.art.has: 14 formulas and 7 figures.

ASSOCIATION: Leningradskiy politekhnicheskii institut im. M.I.Kalinina (Leningrad Polytechnic Institute)

SUBMITTED: 15Jun63

DATE ACQ: 19Jun64

ENCL: 00

SUB CODE: MS

NR REF SCV: 003

OTHER:003

L 6313-65 APPROVED FOR RELEASE Thursday, September 20, 2002 CIA-RDP86-00513R000515610010-2
APPROVED FOR RELEASE Thursday, September 16, 2002
ACC NR: AP5028318 JD/GB/AT SOURCE CODE: UR/0057/65/035/011/2034/2041 LIP(c)

AUTHOR: ^{49.55} Golant, V.Ye.; ^{49.55} Zhilinskiy, A.P.; ^{49.55} Liventseva, I.F.; ^{49.55} Sakharov, I.Ye.

ORG: ^{49.55} Leningrad Polytechnic Institute im. M.I.Kalinin (Leningradskiy politekhni-⁸⁹cheskiy institut)

TITLE: ^{21.74} Electromagnetic radiation from an electron beam traversing a plasma in a magnetic field

SOURCE: Zhurnal tekhnicheskoy fiziki, v. 35, no. 11, 1965, 2034-2041

TOPIC TAGS: ^{21.74} helium plasma, ^{21.74} plasma beam interaction, plasma, plasma oscillation, plasma wave, cyclotron resonance, electron beam

ABSTRACT: The authors have investigated the microwave (3 cm wavelength) fields in and radiation from plasmas produced by 20 to 900 mA beams of 0.8 to 2 keV electrons traversing helium at pressures from 5×10^{-3} to 1×10^{-1} mm Hg in the presence of a 2kOe or weaker uniform longitudinal magnetic field. The plasmas were produced in a 5 cm diameter 40 cm long glass tube containing at one end an electron gun producing a 0.5 cm diameter beam. The electron gun was operated with 2 μ sec pulses at a repetition rate of 50/sec. The radial distribution of the longitudinal microwave electric field was determined with the aid of a uhf probe consisting of a section of twinlead with 4 mm spacing, and the radiated microwaves were received with an open ended wave-

Card 1/2

UDC: 533.9

L 6313-66

ACC NR: AP5028318

guide section located close to the discharge tube. The uhf signals were recorded with a superheterodyne receiver with a 2 Mc passband and a sensitivity of $5 \times 10^{-12} W$. One conductor of the uhf probe was employed also as a Langmuir probe to determine the plasma density. The discharge tube contained in the end opposite the electron gun an anode and a directly heated cathode, with the aid of which a gas discharge plasma could be produced. This plasma was employed to calibrate the Langmuir probe in the presence of the magnetic field and in some other auxiliary experiments. The plasma produced by the electron beam was found to extend far beyond the limits of the beam. The microwave field strength and radiation intensity were investigated as functions of the magnetic field strength, gas pressure, beam current, and electron energy, and the results are presented graphically and discussed. The intensity of the uhf radiation varied greatly with the conditions of operation, but such radiation was observed at magnetic field strengths an order of magnitude lower than that corresponding to the electron cyclotron resonance, and in some cases in the absence of a magnetic field. Further work will be required to elucidate the nature of the coupling between the longitudinal plasma oscillations and the transverse electromagnetic waves which makes the radiation possible. Orig. art. has: 9 figures. [15]

SUB CODE: ME, EM/ SUBM DATE: 18Feb65/ ORIG REF: 011/ OTH REF: 006/ ATD PRESS:
4143

Card 2/2

ACC NR: AP5028319

SOURCE CODE: UR/0057/65/035/011/2042/2051

AUTHOR: Anisimov, A.I.; Budnikov, V. N.; Vinogradov, N.I.; Golant, V.Ye.

87

ORG: Physico-technical Institute im. A.F.Ioffe, AN SSSR, Leningrad (Fiziko-tekhnicheskii institut AN SSSR)

TITLE: Use of open cylindrical resonators in plasma research

SOURCE: Zhurnal tekhnicheskoy fiziki, v. 35, no. 11, 1965, 2042-2051

TOPIC TAGS: plasma diagnostics, electron density, microwave, resonator, resonator Q factor, resonance frequency, helium plasma, *plasma research*

ABSTRACT: Advantages are pointed out of the use of open-ended circular cylindrical resonators rather than closed resonators for measuring electron concentrations in plasmas by the resonance frequency shift method; formulas are presented (most of these are taken directly from the literature) for calculating resonance frequencies, field distributions, and Q-factors of open resonators; and experiments are described which prove the feasibility of using open resonators in plasma diagnostics. There are two basic advantages of the open resonator; the open ends facilitate introduction of the plasma into the resonator, particularly if the plasma is confined in a cylindrical tube; and the resonant frequencies are widely separated, so that the higher modes are relatively easily identified. These features of the open resonator afford the following possibilities; the diameter of the resonator can be made only slightly larger than that of the tube containing the plasma, thus enabling the plasma

UDC: 633.9.07

ACC NR: AP5028319

to fill a large fraction of the resonator volume; a wide range of frequencies can be employed (by using the higher resonant modes), so that a wide range of electron concentrations can be measured; several different modes at widely differing frequencies can be simultaneously excited and their frequency shifts measured; information concerning the radial distribution of electron concentration can be obtained by measuring the frequency shifts of different modes having different radial distributions of the longitudinal electric field component; and an open resonator can be mounted within the plasma container itself. One can also excite the resonator at a frequency above the cutoff frequency at some point near the axis of the plasma column and determine the cutoff radius with the aid of the theory of a coaxial resonator. A 2.3 cm diameter 20 cm long open copper resonator excited in the 3 cm and 8 mm wavelength regions was employed to measure electron concentrations between 3×10^9 and 10^{11} cm^{-3} in helium plasmas excited in a 1.6 cm diameter 50 cm long quartz tube containing helium at 0.2 mm Hg by 20 μ sec discharges. Control measurements were made in the 10 cm wavelength region with a 9.1 cm diameter 3 cm long closed resonator having 2.6 cm diameter openings in the end walls to admit the plasma tube. The effect of the quartz tube on the Q-factor was found to be negligible, and its effect on the resonant frequency shift was determined experimentally. Measurements were made using the E_{011} , E_{012} and E_{221} modes of the open resonator and the E_{010} mode of the closed resonator, and the different measurements were found to be in good agreement with each other. The logarithm of the electron concentration decreased linearly with time, and the scatter of the 25 experimental points from the straight line did not exceed

Card 2/3

~~L 10069-86~~
ACC NR: AP5028319

10%. It is concluded that an open cylindrical resonator can be employed to measure electron concentrations in plasmas. Orig. art. has: 16 formulas, 3 figures and 3 tables.

SUB CODE: 20 SUBM DATE: 15Mar65/ ORIG. REF: 013 OTH REF: 001

Card 3/3

L 13450-66

APPROVED FOR RELEASE: Thursday, September 26, 2002 CIA-RDP86-00513R000515810010-2
APPROVED FOR RELEASE: Thursday, September 26, 2002 EWG (M) IJP(c) AIT

ACC NR: AP6002440

SOURCE CODE: UM/0057/63/035/012/2176/2184

AUTHOR: Golant, V. Ye.; Kaganskiy, M.G.; Ovsyannikov, V.A.; Piliya, A.D.

ORG: Physico-technical Institute im. A.F.Ioffe, AN SSSR, Leningrad (Fiziko-
tekhnicheskij institut AN SSSR)

TITLE: A toroidal machine for adiabatic compression of plasma

SOURCE: Zhurnal tekhnicheskoy fiziki, v. 35, no. 12, 1965, 2176-2184

TOPIC TAGS: plasma heating, plasma compression, ~~plasma confinement, plasma devices,~~
nonhomogeneous magnetic field, *magnetic field, physical laboratory experiment*

ABSTRACT: There is briefly described a new machine, the "Tuman", for ohmic heating and subsequent adiabatic compression of plasma. The chamber is in the form of a racetrack with 60 cm long straightaways and 20 cm radius semicircular ends. In order to meet the conflicting requirements for stable, efficient ohmic heating and high adiabatic compression ratio, the quasistationary longitudinal magnetic field (half-period 3 millisecc) was made strong (up to 50 kOe) in the semicircular end regions and weak (1.5-3 kOe) in the straightaways. The radius of the chamber in the semicircular end regions is 2 cm, and the plasma is stabilized by a 5 mm thick copper liner, which is slotted to permit penetration of the magnetic field. The radius of the chamber in the straightaways is 8.5 cm and the walls are of glass, there being no metallic liners that might reduce the rate of rise of the compressing magnetic

Card 1/2

UDC: 533.9

Card 2/2

SOURCE CODE: UR/0057/66/036/066/1027/1033

AUTHOR: Golant, V. Ye.; D'yachenko, V.Y.; Novik, K.M.; Fodushnikova, K. A.
ORG: Physicotechnical Institute im. A.F.Ioffe, AN SSSR, Leningrad (Fiziko-tekhnicheskii Institut AN SSSR)

TITLE: Investigation of electron cyclotron heating of plasma
SOURCE: Zhurnal tekhnicheskoy fiziki, v. 36, no. 6, 1966, 1027-1033

TOPIC TAGS: plasma heating, cyclotron resonance, hydrogen plasma, magnetic mirror, plasma electron temperature

ABSTRACT: The authors' experiments on heating plasmas in a magnetic mirror system by supplying energy at the electron cyclotron resonance differed from other such experiments in that separate oscillators were employed to produce the plasmas and to heat them. The plasmas were produced in 9 cm diameter, 18.5 or 30 cm long copper resonators containing hydrogen at from 5×10^{-6} to 10^{-3} mm Hg. The shorter resonator communicated via a 3.5 cm diameter hole in an end wall with a glass tube. The resonator in use was mounted between magnetic mirrors (mirror ratio, 1.8) 30 cm apart. When the shorter resonator was employed, the glass tube was in the region of one of the magnetic mirrors; in all cases the copper resonator was between the mirrors. Approximately 100 W of rf power at 9.3-9.5 kHz was continuously supplied to the

UDC: 533.9

ACC NR: AP6018747

SOURCE CODE: UR/0057/66/036/006/1144/1146

AUTHOR: Golant, V.Yo.; Krivosheyev, M.V.; Guchnev, I.L.

ORG: Leningrad Polytechnic Institute im. M.I.Kalinina (Leningradskiy politekhnicheskiy institut)

TITLE: Some properties of an ultrahigh frequency discharge in a magnetic field

SOURCE: Zhurnal tekhnicheskoy fiziki, v. 36, no. 6, 1966, 1144-1146

TOPIC TAGS: rf plasma, discharge plasma, plasma magnetic field, argon, cyclotron resonance, waveguide

ABSTRACT: The authors have investigated plasmas produced by high-frequency discharges in argon at 0.001 to 1 mm Hg in the presence of an up to 1.9 kG magnetic field. The gas was contained in a 1 cm diameter, 80 cm long quartz tube mounted on the axis of a 7 cm diameter waveguide of circular cross section, excited in the TE_{11} mode at 3.15 KMc. The waveguide was so terminated that the standing wave ratio did not exceed 1.3. Approximately 15 cm of the length of the quartz tube was within the high field portion of the waveguide, and the magnetic field strength did not vary by more than 15 over that portion of the tube. The plasmas produced in the quartz tube were investigated with a needle probe and by means of loading by the plasmas of a resonant cavity operating in the 3 cm wavelength region. Visible radiation from the plasmas was recorded with a photomultiplier. The rf electric field strength

Card 1/2

UDC: 533.9

27.6.1966

GOLANTSEVA, N.V. (Dobrinckiy rayon Lipetskoj oblasti)

Midwife's work in a collective farm maternity hospital. Fel'd.
i akush. 2: no.5:48-49 Ny'63. (MIRA 16:7)

(MEDICINE, RURAL) (MIDWIVES)

GOLANSKIY, P.G.

Pneumatic portable saw. Mashinostroitel' no.6:29 Je '63.
(MIRA 16:7)
(Power tools)

20017-001, p. 11. "Mentioned 'Journal of the Medical Services Classification of the
Activity Section for Patients in Medical Institutions."

Verzno-Meditskiy Zhurnal, No. 11, 1961, pp. 1-27.

GOLANTSOV, B.N., podpolkovnik meditsinskoy sluzhby

Classification of the movement regimen for patients in therapeutic
institutions. Voen.-med. zhur. no.11:77 N 1961. (MLA 15:6)
(CARE OF THE SICK)

GOLANTSOV, A.N. (Ivanovo)

Conditions of action regimen for patients in therapeutic institutions.
Sov.med. 28 no.7:135-136 JI '65.

(MIRA 18:8)

GOLAR, Iozef [Golar, Josef] (Praga).

Developing the creative initiative of the masses is the basis for
a labor upsurge on the railways of Czechoslovakia. Zhel. dor. transp.
39 no.5:9-11 My '57. (MLRA 10:6)

1. Zamestitel' ministra transporta Chekhoslovatskoy Respubliki.
(Czechoslovakia--Railroads)

GOLAS, F.Ya.; CHECHIK, V.S.

Boiler rooms with a single unit for heating and hot-water supply.
Vod. i san. tekhn. no.5:6-8 My '58. (MIRA 11:6)
(Boilers)

ORLOV, V.V.; GOLASHVILI, G.V.; VASHIN, A.I.

[Resonance absorption of neutrons by a block] rezonansnoe
pogloshchenie neitronov blokom. Moskva, Glav. upr. po is-
pol'zovaniyu atomnoi energii, 1960. 16 s. (MIRA 17:1)

431
3/6/61, 10, 000/111/037
B104/B112

36.2242
AUTHORS: Gelev, V. V., Golachvili, T. V., Haskin, A. I.

TITLE: Neutron resonance absorption in a lump

SYNOPSIS: Armenian, A. A., Soviet Neutronics Links; Armenian Link; London, 1961, 115 - 122

NOTE: The authors develop a general formula for the effective resonance integral which takes account of the scattering and the slowing down of neutrons in a lump as well as the possibility of a neutron passing through the lump. A survey is given of the formulae of the effective resonance integral which have already been built with (Arakian G. I., Chislovan, Setoye such to yadryakh reaktorey, - Numerical methods of reactor calculation - St. Akh. Atomist, 195; Galois A. B., Teoriya yadryakh reaktorov na toplotykh naybavkakh - Theory of thermal reactors - Atomist; Galois A., Chernick J., Germolov, Lecture no. 1017, 1957 and international Conference on the Peaceful Uses of Atomic Energy, Geneva, 1958). The authors derive Birmer's formula for the resonance integral I_{eff} as follows:

Cont 1/2

SECRET
CONFIDENTIAL

Document number:

Reference to the document type is to the document number. The document
is classified as CONFIDENTIAL and is not to be disseminated outside the
agency. It is to be controlled in accordance with the provisions of the
Executive Order on the subject of the document.

SECRET

26.2245
 S/089/62/012/002/011/013
 B102, B138

AUTHOR: Golashvili, T. V.

TITLE: The effect of a resonance absorber on the absorption of slowed-down neutron by a nucleus with smoothly varying absorption cross section

PERIODICAL: Atomnaya energiya, v. 12, no. 2, 1962, 155-156

TEXT: An expression is derived for calculating capture cross section allowing for a resonance absorber, and another one is obtained for the screening factor. This latter was calculated for U^{235} in a natural $U^{235}-U^{238}$ mixture and for 10% enrichment at 66 eV. The absorption cross section of nucleus A is taken as constant and the resonance integral for A,

$$I_{\sigma}^{(A)} = \int \frac{\sigma_A \sigma_A^R}{\sigma_A + \sigma_A^R + \sigma_A^N (1-x)} \frac{dE}{E} \quad (1)$$

Card 1/3

33277
S/089/62/012/002/011/013
B102/B138

The effect of a resonance absorber...

($\mu \neq \text{eff.}$, eff. per.) The numerical results are tabulated. W. V. Orlov is the lead for discussions, M. G. Zuyev for calculations. There are 2 tables and 1 non-Soviet reference. The reference to the English-language publication reads as follows: D. Hughes et al. Neutron Cross Section. McGraw Hill Co., Jan. 1960.

SUBMITTED: May 8, 1961

Card 3/3

21/1/62
13/11/62

S/089/62/013/005/001/012
B102/B104

AUTHORS: Golashvili, T. V., Kibili, I. M.

TITLE: Screening effect of U²³⁸ resonances on U²³⁵-resonance absorption

PERIODICAL: Atomnaya energiya, v. 13, no. 5, 1962, 435-439

TEXT: The problem of the mutual influence of neutron resonance absorption by U²³⁸ and by U²³⁵ inside the fuel lump where resonance absorption can be considered as volume absorption, is treated both theoretically and practically. This problem is important for elements operating with natural or enriched uranium because the U²³⁸ resonance levels are near those of U²³⁵ and the U²³⁸ absorption cross sections are larger than those of U²³⁵. For fuel with the enrichment x the effective resonance integral

$$I_{235}^{(e)} = \int_E \frac{\sigma_a^{235} \sigma_a^{238}}{\sigma_a^{235} + \sigma_a^{238} x + \sum_i \sigma_{0i}^{235} (1-x)} \frac{dE}{E} \quad (3)$$

Screening effect of U^{238} resonances on ...

S/089/62/013/005/001/012
B102/B104

can be represented by

$$I_{\text{eff}}^{5(3)} = \sigma_0 \int \frac{1}{1 + \left(\frac{E - E_n}{\Gamma} \right)^2} \frac{dE}{E} \left[\sigma_4 + \left[\frac{\sigma_a}{1 + \left(\frac{E - E_n}{\Gamma} \right)^2} \right] \left(1 + \frac{\Gamma_n \Gamma_x}{\Gamma^2} \right) r \right] + \left[\frac{\sigma_s}{1 + \left(\frac{E - E_n}{\Gamma} \right)^2} \right] \left(1 + \frac{\Gamma_n}{\Gamma_x} \right) (1 - r) \quad (4)$$

using the Breit-Wigner formula and allowing for the neutrons absorbed by U^{238} . Summation is made over all U^{238} levels influencing the U^{235} -neutron absorption. $\sigma_0 = \sigma_a + \sigma_s + \sigma_f$ is the sum of resonance absorption, resonance scattering, and fission cross sections, σ_s is the potential scattering cross section, the superscripts 5 and 8 refer to U^{235} and U^{238} .

S/089/62/013/005/001/012

Screening effect of U^{238} resonances on...B102/B104

$I_{\text{eff}}^5 = \int_a^b \frac{\sigma_s}{\sigma_t} dE/E$ and $I_{\text{eff}}^{5(8)}$ were calculated for the neutron energy range 4 ev $\leq E \leq 60$ ev for natural uranium and uranium enriched to 10%. The screening coefficient $k_{\text{scr}}^{5(8)} = \frac{\sum_i I_{\text{eff } i}^{5(8)}}{\sum_i I_{\text{eff } i}^5}$ was 0.76 for natural and 0.81 for enriched uranium. The experiments were made with a quadratic lattice of U^{238} rods 35-mm thick and enriched in U^{235} to 2% in a uranium-graphite reactor. Direct measurements of the effective resonance integral of U^{238} gave $RI_1 \approx 9.2 \pm 0.3$, a value close to that of volume resonance absorption (8.1b). $k_{\text{scr}}^{5(8)}$ was 0.88 ± 0.03 . The deviation from the theoretical value may be due to the fact that the neutrons contributing to this effect are not only of the energy range 4-60 ev but of all energies above 0.4 ev. There are 2 figures and 1 table.

SUBMITTED: January 11, 1962

Card 3/3

GOLASHVILI, T.V.

Resonance absorption of neutrons in heterogeneous reactors.
Trudy Inst.fiz.AN Gruz,SSR 8:41-50 '62. (MIRA 16:2)
(Nuclear reactors) (Neutrons--Capture)

L 04222-97 ENT(2)

ACC NR: AR6031860

SOURCE CODE: UR/0058/66/000/006/V055/V055

AUTHOR: Golashvili, T. V.

16
B

TITLE: Multiplication factor in fast neutrons in a ring unit with an internal scatterer

14

SOURCE: Ref. zh. Fizika, Abs. 6V460

REF SOURCE: Byul. Inform. tsentra po yadern. dannym, vyp. 2, 1965, 288-290

TOPIC TAGS: fast neutrons, multiplication factor, internal scatterer

ABSTRACT: Formulas and numerical values are given for the probability of a first collision in a ring unit between a fast neutron and an arbitrary scatterer inside the unit for three values of the total cross-section of the scatterer. [Translation of abstract]

SUB CODE: 18, 20/

Card 1/1 *glw*

1/10/68

1/10/68

1/10/68

1/10/68

GOLASKI, Janusz

Techniques of inventory and land partition in the 13th
century as shown by the city and land records of Poznan.
Przeł gl geod 36 no. 4:141-143 Ap '64.

KRZYSZKOWSKA, Anna; ZIOLECKA, Izabella; RZUCIDLO, Ludwik; GOLASZEWSKA, Wiktoria; STUDNICKA, Krystyna; TYSZKA, Krystyna; WERYŚ, Ryszard

Comparative tuberculin reactions to the A or A + B proteins and to the PPD tuberculin prepared from the Moreau strain of tubercle bacilli in tuberculous and BCG-vaccinated children. Gruzlica 31 no.9:945-954 '63.

1. Z Zakładu Epidemiologii Instytutu Gruzlicy w Warszawie
Kierownik: doc. dr O. Buraczewski Dyrektor: dr M. Juchniewicz
Z Wytworni Surowic i Szczepionek w Warszawie Dyrektor: dr
S. Brzezinski Z Dziecięcego Ośrodka Sanatoryjno-Prewentoryjnego
w Rabce Dyrektor: dr J. Rudnik Z Beskidzkiego Ośrodka Sana-
toryjno-Prewentoryjnego w Jaworzu Dyrektor: dr M. Nizegorodcew
Z Sanatorium Przeciwgruzliczego dla Dzieci w Łagiewnikach
Dyrektor: prof. dr A. Margolisowa Z Wojewodzkiej Przychodni
Przeciwgruzliczej w Krakowie Dyrektor: dr K. Mulak.
(BCG VACCINATION) (TUBERCULOSIS IN CHILDHOOD)
(TUBERCULIN REACTION)

13. NAME, Given Names

Country: Poland

Academic Degrees:

Affiliation:

Source: Warsaw, Medycyna Weterynaryjna, Vol XVII, No 5, May 1961, pp 281-285.

Data: "Infectious Virus Gastroenteritis in Pigs."

Authors:

JANCUSKI, Henryk, Docent dr., Director of the Department of Hog Diseases (Zakład Chorob Swin), Veterinary Institute (Instytut Weterynaryjny), Pulawy.

GOLASZEMSKI, Henryk, Dr., Director of the Wojewodztwo Veterinary Hygiene Department (Wojewodzki Zakład Higieny Weterynaryjnej), Szczecin

GPO 981643

, 18

OTA GOLASZEWSKI, W

1494
GOLASZEWSKI, R. Portable Steel Casing for Concreting Bridge Piers
Przenośny pałasz stalowy dla betonowania filarów mostów
Inżynierstwo No. 8, 1971, pp. 244-247, 10 figs

Conception of a portable steel casing consisting of a number of 4 mm gauge steel sheets, stiffened by 50 x 50 x 5 mm angle plates which at the same time serve by means of bolts to interconnect the individual casing elements. The casing is intended for concreting pier walls in layers. Description of a number of work phases carried out with the casing. The casing is removed when the facing part of the wall begins to rise above water level. Drawing illustrating the device. Annual savings estimate. One unit can, on the basis of an estimated life of five years, be used for carrying out 30 bridge piers, which is tantamount to a saving of timber of approximately 2000 m³.