

GLAZKOV, Ye. V.

11-4-6 19/50

AUTHOR: Glazkov, Ye. V.

TITLE: Infrared Reflection Spectra of Crystallization Products of Certain Glasses of the $\text{Na}_2\text{O}-\text{SiO}_2$ System.(Infračervená spektra strážbených produktů krystalizace některých skelných systémů $\text{Na}_2\text{O}-\text{SiO}_2$)

PERIODICAL: Optika i Spektroskopiya, 1959, Vol. IV, No. 3, pp. 400-402 (USSR)

ABSTRACT: The present paper reports results of measurements of the reflection spectra of compounds $\text{Na}_2\text{Si}_2\text{O}_6$ and Na_2SiO_3 in the 7-24 μ region and the reflection spectra of crystallization products of glasses of the $\text{Na}_2\text{O}-\text{SiO}_2$ system. The reflection spectra were measured using an IKS-11 spectrometer with NaCl and KBr prisms in non-polarized light at an angle of incidence of about 25° . Crystallization of glasses was carried out by heating for 5 hours in a platinum furnace. Fig. 1 shows the reflection spectra of glasses crystallized at temperatures near to the liquidus. Curve 1 represents the reflection spectra of a glass containing

Card 1/3

604-2-15/30

Infrared Reflection Spectra of Crystallization Products of
Certain Glasses of the $\text{Na}_2\text{O}-\text{SiO}_2$ System.

50 mol.% of Na_2O and 50 mol.% of SiO_2 , which is the composition of sodium metasilicate, crystallized at 10^{10} - 10^{12} °C. The results of the reflection spectrum of a crystallized glass containing 33.3 mol.% of Na_2O and 66.6 mol.% of SiO_2 (sodium metasilicate composition). Fig.2 shows the spectra of a series of glasses crystallized at 620°C (curves 3-7). Thermal treatment of the samples represented by curves 3-7 in Fig.2 is given in the table on p.400. Fig.2 contains also the reflection spectra of quartz (curve 1) and cristobalite (curve 2) drawn using the data given in Ref.5. The results obtained indicate that in crystallization of glasses whose composition is the same as composition of chemical compounds, the crystallization product is the corresponding compound. On crystallization of glasses with a stoichiometric composition separation out of silicates with a higher content of silicon than in sodium metasilicate probably

Card 2/5

Infrared Reflection Spectra of Crystallized Products of Certain
Glasses of the $\text{H}_2\text{O}-\text{SiO}_2$ System. 3. 4. 19/30

There are 2 figures, 1 table and 1 reference,
of which 5 are Soviet and 1 American.

ASSOCIATION: State Optics Institute, Leningrad, U.S.S.R.
(Geodachennyy opticheskiy institut im. S.I. Vavilova.)

SUBMITTED: June 5, 1957.

1. Glass--Crystallization
2. Furnaces--Applications
3. Glass--Properties--Reflection spectra

Card 5/5

GLAZKOV, Yu.V.

Applying infrared spectroscopy in studying the crystallization
of $\text{Na}_2\text{O-SiO}_2$ -system glass [with summary in English]. Inzh.-fiz.
zhur. no.1:96-100 Ja '59. (MIRA 12:1)

1. Institut fiziki i matematiki AN BSSR, Minsk.
(Glass-Spectra) (Crystallization)

SOV. JTC- 9-3-11/70

AUTHOR: Glazkov, Yu.V.

TITLE: The Application of Infrared Spectroscopy to the Study of Crystallization of Glasses of the $\text{Na}_2\text{O}-\text{SiO}_2$ System (Primeneniye infrakrasnoy spektroskopii k izucheniyu kristallizatsii stekol sistemy $\text{Na}_2\text{O}-\text{SiO}_2$)

PERIODICAL: Inzhenerno-fizicheskiy zhurnal, 1959, Nr 6, pp 97-99 (USSR)

ABSTRACT: Results of crystallization study of a glass whose composition is equivalent to the eutectic one are described in the article. A peculiarity of such compounds consists in that two chemical compounds comprising the eutectic structure appear simultaneously in crystallization of an alloy of two-component systems. The author investigated the glass containing 39.5 mol. per cent Na_2O , and the chemical compounds expected to appear in crystallization should be sodium disilicate and silica. The spectra of these compounds are known, and this provides a possibility to study the process of crystallization of the glass of eutectic structure. The investigation was carried out by studying infrared reflection spectra of partially and fully crystallized glasses in the range from 7 to 15 microns. The spectra obtained, however, differ from those expected and therefore cannot be interpreted as those of a eutectic silicate-silica alloy.

Card 1/2

SOV/170-59-3-14/20

The Application of Infrared Spectroscopy to the Study of Crystallization of Glasses of the $\text{Na}_2\text{O}-\text{SiO}_2$ System

Because of the lack of spectroscopic data on crystallization of two-component systems, the number and type of crystals obtained cannot be precisely identified, although there are indications as to the presence of cristobalite and some other silicates distinctive from the solid solution. This investigation was performed under the guidance of V.A. Florinskaya. There are 3 graphs and 6 Soviet references.

ASSOCIATION: Institut fiziki i matematiki AN BSSR (Institute of Physics and Mathematics of the AS of the Belorussian SSR), Minsk.

Card 2/2

5274
09/13-50-1-5/2

2A(2,7)

AUTHOR: GLAZKOV, Ya.V.

TITLE: The Application of Infrared Spectroscopy to the Study of Crystallization of Glass of the Na₂O - SiO₂ System

PERIODICAL: Inzhenerno-fizicheskiy zhurnal, 1959, No. 7, pp. 29 - 34 (USSR)

ABSTRACT: The author studied the crystallization process of glass of the Na₂O - SiO₂ system containing 20 and 30 mol.% of Na₂O under conditions of high overcooling. The identification of crystallization products was made by infrared reflection spectra in the region of 7 to 15 microns. Figure 1 presents spectra of glass crystallization products heated during 22 hours up to different temperatures including 1,000°C. The changes in spectra are described and analyzed. The changes can be interpreted with the aid of the equilibrium diagram. For crystallization at temperatures of 500 - 1,000°C a characteristic feature is formation of very small crystals scattered over the entire volume of glass. On the surface of the specimens a thin, but sufficiently microlithic film was formed. A comparison of the spectrum of these crystals with that obtained by Sevchenko [Ref 7] shows that it agrees with the spectrum of tridymite. Figure 2 shows reflection spectra of glass heated to 600°C, i.e., below

Card 1/3

05274

00V10-3-1-572

The Application of Infrared Spectroscopy to the Study of Crystallization of Glass of the $\text{Na}_2\text{O} - \text{SiO}_2$ System

eutectic temperature. In this case, crystallization can not be described with the aid of the equilibrium diagram. A crystallo-optical investigation of its products, carried out by Mukhin, has shown that the main mass of crystallization products is a substance with refraction index differing considerably from those of sodium disilicate and silica (Table II). It can be assumed that the surface of glass contains small crystals of cristobalite. There is a difference between the spectra of crystallization products formed on the surface of the specimens and inside of them. Figure 3 shows crystallization spectra of glass containing 50% of Na_2O . It was found that during the process of lengthy crystallization, the silicates formed are subject to considerable changes the nature of which has not as yet been clarified. Crystallization products formed on the surface of the specimens were also studied, and the results of the earlier studies on the

Card 2/3

05274

SOV/170-59-7-5/20

The Application of Infrared Spectroscopy to the Study of Crystallization of Glass of the
 $\text{Na}_2\text{O} - \text{SiO}_2$ System

surface crystallization were confirmed. In conclusion the author thanks
V.A. Florinskaya for the guidance and assistance in this investigation.
There are: 3 graphs, 1 table and 8 Soviet references.

ASSOCIATION: Institut fiziki i matematiki AN BSSR (Institute of Physics and Mathematics
of the AS Belorussian SSR), Minsk.

Card 3/3

Glazkov, Yu. Yu.

1978-01-15

AUTHORS: Kozlov, I. K., Zamiatyevskiy, V. S., Grigoryev, I. V.,
Korotkiy, I. V., Glazkov, Yu. Yu., Babitskiy, B. S.

TITLE: Test Reactor With Gaseous Active Material (HE) and Secondary
reflector a gaseobraznyy dolyabotomayk reaktor s HE,

PERIODICAL: Energiya, 1978, Vol. 1, No. 1, pp. 101-102 (1978)

ABSTRACT: The reactor is of the heterogeneous type, the moderator consists of metallic beryllium (170 kg), and graphite is used as a reflector. The beryllium was available in form of cubes the edges of which had a length of 40 mm. The active zone is a cylinder of 160 mm diameter and 690 mm height. The active zone (not enriched) uranium hexafluoride filled 128 channels which were arranged in form of a quadratic lattice with a spacing of 80 mm. The channels consisted of quadratics of uranium tubes of 40 x 40 x 1 mm. 4, 8, 10, 12, and 14 channels are arranged in a row, one beside the other. The working volume of a channel within the domain of the active zone is 140 cm³. The total volume of the active zone is 114 l. The lateral graphite reflector has a thickness of 200 mm, which is the radius of the

Page 1 of 4

A Test Reactor With Gaseous Fissile Material ^{235}U

15

Upper and lower reflectors is 400 mm. A 100 mm diameter, 100 mm long, 10 mm diameter pass through the upper reflector is available to feed the gas into the reactor. Two vertical channels are provided for regulation of the gas flow. The reactor can be heated from the outside by means of electrical resistance of 45 kw. Heating the reactor to a temperature of 40 - 90°C takes 10 - 15 hours. The reactor is located in a shield casing of 200 mm diameter. The reactor is hermetically sealed. Rubber gaskets are used for the seal. The system for the blowing-in and out of gas consists of a pump for uranium-hexafluoride, emergency system, a number of apparatus, and remote-controlled valves. Reactor control is carried out by hand. The regulating rods are 100 mm long, with a diameter of 32 and 9 mm, which are filled with boron carbide. In August 1957 the reactor became critical for the first time. The quantity of gas operating was 1.10 g ^{235}U . The maximum power output has not been attained. The maximum power output is 100 kW. At this power level a neutron flux of 10^{14} neutrons/cm² was measured at the center of the reactor. The maximum neutron flux is 10¹⁴ neutrons/cm² at the center of the reactor.

A Test Reactor With Gaseous Fissile Material (UF_6)

SOV/89-8-3-8/15

plotted. For the reactivity ρ the value

$$\rho = 1,55 \cdot 10^{-4} \Delta m g$$

was found. The dependence $\rho(t)$ is plotted (t denotes the time within which the neutron flux increases up to e -fold its amount). The temperature coefficient was measured and shown in form of a graph. The dissociation rate of the molecules UF_6 was determined as amounting to 0,32 mol/kWh. The addition of chlorotrifluoride shows that working conditions can be found in which stability of radiation of the uranium-hexafluoride in the reactor can be attained. A. M. Susova assisted in assembling the apparatus in collaboration with A. A. Krasin. There are 12 figures and 3 references, 1 of which is Soviet.

Card 3/3

21.1800

S/089/61/010/004/015/027
B102/B205

AUTHORS: Glazkov, Yu. Yu., Dubovskiy, B. G., Kuznetsov, F. M.,
Semenov, V. A., Pen Fan

TITLE: Study of thermal-neutron spectra in physical reactors by
means of monochromators

PERIODICAL: Atomnaya energiya, v. 10, no. 4, 1961, 481-483

TEXT: The experiments described in this "Letter to the Editor" were carried out in a uranium-graphite reactor, in the center of which a sub-critical assembly was installed. In order to determine the optimum diameter of the sub-critical assembly, the experiments were made at different diameters of the assembly. The monochromators used for the purpose were designed for measuring thermal-neutron spectra in physical low-power reactors (cf. A. P. Senchenkov, F. M. Kuznetsov, Atomnaya energiya, 2, vyp. 2, 124 (1958)). The number of neutrons recorded by the detector per second was calculated from the relation

X

$$N = \frac{n(v_0)v_0}{4} \frac{1}{2\pi} Sdh \frac{d}{H} \frac{S}{L} \frac{h}{L} \frac{v_0^2 \eta \delta}{(\omega_{rcp})^2} \nu \frac{n}{60}$$

Card 1/5

22612

S/089/61/010/004/015/027
B102/B205

Study of...

where N is the number of counts of the detector per second, $n(v_0)v_0$ the neutron flux in the center of the reactor per unit interval of velocity, n the speed of the rotor per minute; S , L , and h are the width, length, and height of the collimator; d is the width of the rotor gap, H the length of the rotor, r_{cp} the distance between the axis and the center of the rotor gap, ν the number of rotor gaps, $v_0 = \omega r_{cp} / \alpha_0$ the velocity of fission neutrons for a given angle of rotation α_0 and a given angular velocity ω of the rotor, η the efficiency of the detector for neutrons of velocity v_0 , and δ a coefficient accounting for the absorption of neutrons of velocity v_0 in air. The resolution of the monochromator is given by

$$\frac{\Delta v}{v_0} = \frac{v_0}{\omega r_{cp}} \left[\frac{S}{L} + \frac{1}{3} \frac{d}{H} + \frac{1}{4} \frac{h}{r_{cp}} \left(1 + \frac{H}{L} \right) \frac{\omega r_{cp}}{v_0} \right],$$

where Δv is the half-width of the resolution curve and $S/L + d/3H$ the half-width of the statistical transmission curve. The resolutions of the

Card 2/5

Study of...

22612
S/022/61/010/004/015/027
B101/E205

monochromator for $\omega = 5000$ rpm are compiled in a table. The medium column gives the neutron energy. Uranium enriched to 1.2% was used in the sub-critical assembly, whereas the uranium used in the outer zones of the reactor was enriched to 2% (see Fig. 1). The neutron spectrum was taken for three different sizes of the central sub-critical assembly. These spectra, as well as the neutron distribution in a lattice consisting entirely of working channels with uranium enriched to 2%, vary only slightly. All of them attain a maximum at $v_0 = 3$ km/sec and drop to zero at 7-8 km/sec. Fig. 3 shows the temperature of the neutron gas versus the number of working channels with uranium enriched to 1.2% in the sub-critical assembly. It is seen that the spectrum of the assembly having 37 cells is equal to that of a critical assembly consisting of working channels only. The authors tested assemblies with 13, 25, and 37 cells. The assembly having 37 cells had an equivalent radius of 63 cm, the moderation length was 17 cm, and the diffusion length was 14 cm. Such a monochromator can therefore be used to determine thermal-neutron spectra in low-power reactors. The effective temperature of the neutron gas can be calculated with an error of $\pm 4\%$, provided the spectrum

Cont 3/5

22612

Study of...

S/082/51/013/004/015/027
B102/8205

deviates only slightly from the Maxwellian spectrum. There are 3 figures, 1 table, and 1 Soviet-bloc reference.

SUBMITTED: December 7, 1960

Legend to Fig. 1: I - cell;
II - channel with uranium
enriched to 2 %; III - channel
with uranium enriched to 1.2 %;
1) steel.

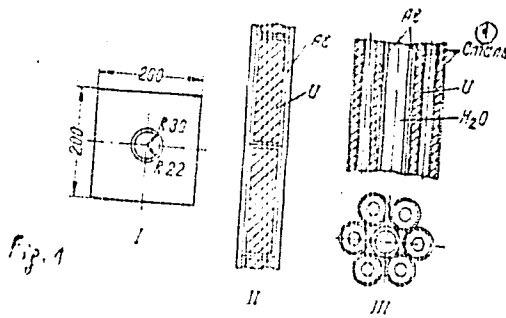

См. 4/5

GLAZKOV, Yu. Yu.

21(4)
International Conference on the Peaceful Uses of Atomic Energy,
2nd, Geneva, 1958.

Doklady sovetskikh uchenykh; Vvedeniye reaktory i yadernaya energiya. (Reports of Soviet Scientists; Nuclear Reactors and Nuclear Power) Moscow, Atomizdat, 1959. 707 p. (Series: Its Study, vol. 2) Krata slup inserted. 3,000 copies printed.
General Eds.: N.A. Dollezhal, Corresponding Member, USSR Academy of Sciences, A.K. Kuznetsov, Doctor of Physical and Mathematical Sciences, A.I. Leybnitskiy, Member, USSR Academy of Sciences, V.V. Kovikov, Corresponding Member, USSR Academy of Sciences, V.V. Kuznetsov, Doctor of Physical and Mathematical Sciences, and V.S. Alyubayev; Tech. Ed.: Ye. I. Mazur.

PURPOSE: This book is intended for scientists and engineers engaged in reactor designing as well as for professors and students of higher technical schools where reactor design is taught.

COVERLET. This is the second volume of a six-volume collection on the peaceful use of atomic energy. The six volumes contain the reports presented by scientists at the Second International Conference on Peaceful Uses of Atomic Energy held from September, October, and November, 1958 in Geneva. Volume 2, Atomic Energy, held from September, October, and November, 1958 in Geneva. The book is devoted to atomic power plants of three parts. The first part, entitled "Theoretical Problems of the Design of Atomic Power Plants," is carried out on them, and the second part, the atomic power reactors, is carried out on them. The third part, the nuclear reactor, is predominantly theoretical. The book is written by Soviet scientists and engineers. The editor of this volume is Yu. Yu. Glazkov.

Kostovoy, V.I., V.S. Dikarev, M.B. Yegorov, and Yu. S. Galitskov. Measuring Neutron Spectra in Uranium Ester Lattices (Report No. 2154)	546
Krasin, A.K., B.D. Dobovskiy, M.M. Lantsov, N.Yu. Olszich, R.K. Zomcharov, A.V. Gerasimov, G.A. Gerasova, V.V. Vityayev, Ye. I. Chiryatov, and A.P. Zhurav. Studying the Physical Characteristics of a Beryllium Moderator Reactor (Report No. 2146)	555
Galenin, A.D., S.A. Kozlovskiy, A.P. Rudik, Yu. G. Abay, V.P. Beikin, and P.A. Krupnikitskiy. Theoretical Experiment on an Experimental Heavy-water Reactor (Report No. 2036)	570
Karchuk, G.I., V. Ya. Pukko, Ye. I. Popudalova, V.V. Selez, I.P. Tyuterev, S. Ya. Akachova, and G.I. Druzhinina. Research in Nuclear Reactor Physics and Methods of Calculation (Report No. 2151)	588
Shoyutin, G.V. and V.N. Sazonov. Determination of Control Rod Effectiveness in a Cylindrical Reactor (Report No. 2207)	613
Gel'fand, I.M., S.K. Pavlov, A.S. Frolov, and M.Z. Zhuravskiy. Using the Monte Carlo Method to Study the Kinetic Equation (Report No. 2147)	624
Malatin, M.I. Neutron Distribution in a Heterogeneous Medium (Report No. 2145)	634
Karamovskiy, R.V., A.V. Stetsko, and P.L. Shaplov. Neutron Thermalization and Diffusion in a Heavy Water Reactor (Report No. 2143)	651
Yemik, A.I., V.S. Yermakov, and V. Ya. Lyub. Using the Operator Method for Studying Neutron Diffusion in the Absorbing Media of Nuclear Reactors (Report No. 2224)	663
Brodskiy, D.L., S.A. Kurkin, A.A. Kutuzov, V.V. Levin, and V.V. Orlov. Studying the Spatial and Energy Distribution of Neutrons in Different Media (Report No. 2147)	674
Matryayev, A.B. Boron Ionization Chambers for Work in Nuclear Reactors (Report No. 2034)	690
Kirillin, V.A. and S. G. Glavin. Experimental Determination of Specific Volumes of Heavy Water in a Wide Temperature and Pressure Range (Report No. 247)	696

CHAZKOV, Yu. Yu.

21(4) PHASE I BOOK EXPLOITATION SOV/253
 International Conference on the Peaceful Uses of Atomic Energy,
 Zhd, Geneva, 1958.
 Doklady sovetskikh uchenykh; Yadernyye reaktory i yadernyye ener-
 getika (Report of Soviet Scientists; Nuclear Reactors and
 Nuclear Power), Moscow, Atomizdat, 1959. 707 p. (Series; 1st
 Trudy, vol. 2) Extra slip inserted. 5,000 copies printed.
 General Eds.: M.A. Dollezhal, Corresponding Member, USSR Academy of
 Sciences, A.K. Krasin, Doctor of Physical and Mathematical Sciences,
 A.I. Kovalev, Candidate of Physical and Mathematical Sciences,
 V.I. Kovilny, Member, Ukrainian SSR Academy of Sciences, I.
 Purov, Doctor of Physical and Mathematical Sciences, I.
 Alyabyev; Tech. Ed.: Ye. I. Mizel.
 PURPOSE: This book is intended for scientists and engineers engaged
 in reactor designing, as well as for profs, students and students of
 higher technical schools where reactor design is taught.
 COVERAGE: This is the second volume of a six-volume collection on the peaceful
 use of atomic energy. The volumes contain the reports pre-
 sented by Soviet scientists at the Second International Conference
 on the Peaceful Uses of Atomic Energy held in Geneva, Switzerland,
 in 1958. Volume 1 contains the reports presented at the first
 session of the conference, which took place in Geneva from September 13 to 17,
 1958. Volume 2 consists of reports presented at the second session, which
 took place in Geneva from September 18 to 22, 1958. The first is
 devoted to atomic power plants under construction. The first is
 devoted to the present status and development of atomic energy in the
 USSR and in other countries. The second is devoted to the design of
 power reactors, which is the main theme of the book. The third is
 devoted to the physics and engineering aspects of nuclear reactors. The
 fourth is devoted to the theory of neutron multiplication. The fifth is
 devoted to the theory of neutron moderation. The sixth is devoted to
 the theory of neutron detection. The book contains many references
 to other articles in the series. References appear at the
 end of the articles.

PART II. EXPERIMENTAL AND RESEARCH REACTORS

219
 Lomonosov, V. V., and M. M. Mikhlin. (Referred to in the text as "Mikhlin and Lomonosov") Experimental and research reactors in the USSR. (Report No. 219)
 220
 Koncharov, Z. V., and G. L. ... Some new and results thermal research
 reactors (Report No. 215)
 221
 Bronnikov, B. V., ... Disassembling an electric power plant from
 isotope producing reactor after four years of operation (Report
 No. 2207)

PART III. DESIGN AND ENGINEERING OF REACTOR DESIGN

222
 Lavrenko, A. I., A. I. Abramov, V. N. ... Homogeneous natural Uranium reactor
 (Report No. 2246)
 223
 Feynberg, S. M., Ye. T. Antiferov, V. P. ... Self-regulation in a water-cooled power reactor
 (Report No. 2188)
 224
 Sidorenko, V. A. ... Self-regulation in a water-cooled power reactor
 (Report No. 2188)

24472

S/082/81/01/001/001/010
R/02/5811

21,1000

AUTHORS:

Glazkov, Ya. Ya., Peresov, L. A., Dubovskii, B. G.
Krasov, A. M., Kuznetsov, I. M., Kuznetsov, F. M., Semakova
Ya. M., Shchegoleva, Ye. V., Stetsko, A. V., Tolstunov

TITLE:

Investigation of the physical characteristics of the
of a certain crystalline structure by means of a certain
insert

PERIODICAL:

Atmospheric Physics, 1981, Vol. 27, No. 1, p. 1-10

TEXT: This paper gives a description of the experiments carried out from
the beginning of 1978 to investigate the physical properties of the
lattice of a certain graphite and its structure. The lattice constant
A quadratic lattice (period 100 nm) was studied; the shape of the lattice
high and wide diameter of 1 cm; its height was 1 mm. The thickness of the
depending on the radius this was 1 mm. The thickness of the lattice was
thick; the height of the lattice was 1 mm. The thickness of the lattice
the composition of the lattice. The structure of the lattice was studied

Card 1/2

35-2

Handwritten notes: s/... /.../...
1972

Investigation of the

were different. The tubes were arranged in a grid and the outer one was...
 and the outer one... reactor structure. The... of the...
 uranium were... the type Bel parashaya IRIS (Bel...
 ring-shaped... enriched uranium...
 insert. Each fuel element... around a central tube.
 The reactor of the IRIS also... and
 steam-superheating channels; they were... the central
 tube filled with water... and having...
 latter. The characteristics of the systems studied were...

✓

25412

INVESTIGATION OF THE ACTS OF
TERRORISM COMMITTED BY
THE ORGANIZATION OF THE
ARAB BOYCOTT

1. The Organization of the Arab Boycott (OAB) is a
terrorist organization which has been active in
the Middle East since 1945. It is a
branch of the Arab League and is
dedicated to the destruction of the
State of Israel. The OAB has
been responsible for a number of
acts of terrorism, including the
bombing of the King David Hotel in
Jerusalem in 1946 and the
bombing of the Tel Aviv
Embassy in 1954. The OAB
has also been responsible for
the assassination of the
Prime Minister of Israel,
Ben-Gurion, in 1956.

X

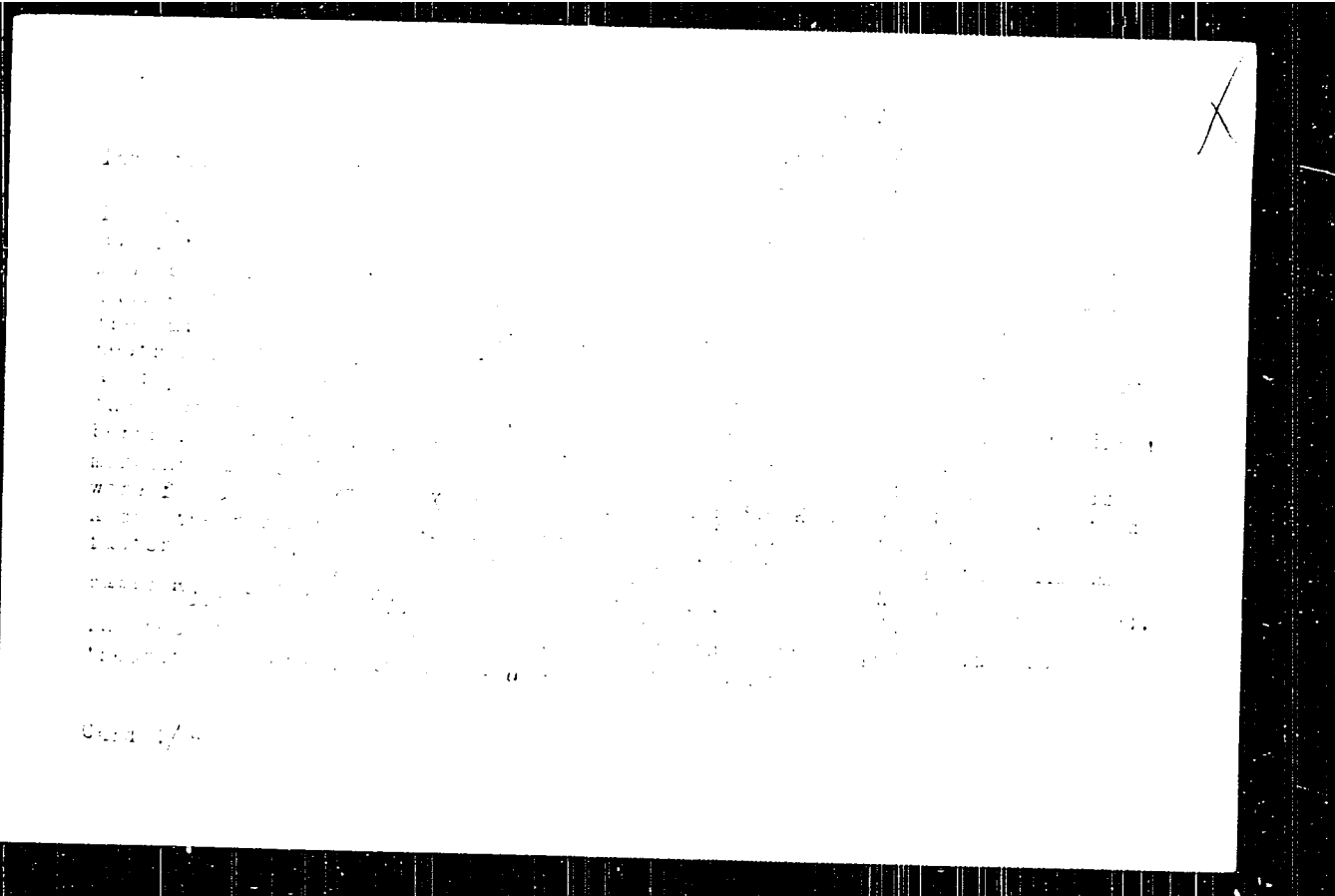

25372
S/089/61/011/001/001/010
B102/B214

Investigation of the ...

Position of the channel

	Value of μ	
	experimental	theoretical
Central channel of an insert of 21 channels with water	1.040±0.005	1.033
One channel with water in the center of a thermal graphite column of 70 cm diameter	1.035±0.005	1.030
Central channel of an insert of 21 channels without water	1.04±0.005	1.035

θ for the GRES type reactor was found to be 0.64 (for channel with water) and 0.65 (without water). It was found that, in order to adjust the neutron spectrum in the center of the subcritical insert so that it is characteristic of the given uranium - graphite lattice, it is necessary to choose the dimensions of the insert so that its equivalent radius is

$\sim 3(\sqrt{\tau+L^2})$ cm ($\sqrt{\tau}$ is the slowing down length in the moderator and L the diffusion length). To measure μ it is sufficient to arrange one cell of the lattice under study in the center of the reactor with ϵ_2 enriched uranium. The authors thank Ye. F. Zakharov, I. M. Viatnikov, I. I. Sidakov,

Caru 5/8

25372

Investigation of the ...

5/10/1961/2.1/21/510
31.2/3214



V. N. Fofanov, V. V. Vavilov, V. A. Semenov, A. N. Galanin, M. V. Bakhtina, M. K. Timonina, A. T. Anfilatov, Yu. S. Birjukin, Yu. I. Starykh and A. P. Delgolenko for collaboration; and A. V. Kamayev, M. Ia. Minashin, G. Ya. Rumyantsev and I. G. Morozov for their interest and discussions. There are 3 figures, 4 tables, and 12 references: 3 Soviet-bloc and 4 non-Soviet-bloc. The three references to English-language publications read as follows: M. Kuche, Nucl. Sci. Engng. 2, No. 1, 96 (1957); D. Klein et al. Nucl. Sci. Engng. 2, No. 4, 403 (1958); J. Volpe et al. Nucl. Sci. Engng. 2, No. 6, 360 (1959).

SUBMITTED: December 12, 1960

Legend to Table 3: 1) number of the cells in the insert, 2) homogeneous lattice, 3) construction of the elements and enrichment of the uranium, 4) ring-shaped elements with water, 1.2%, 5) idem, 6) the same without water, 7) 35 cm thick rods of natural uranium, 8) 35 mm thick rods of 2% enriched uranium, 9) experimental, 10) calculated, 11) in the fuel element (according to fragment accumulation), 12) in the graphite of the central cell, 13) in the fuel element. *calculated according to V.V. Orlov; **in agreement with the measurements of M.B. Yegiazarov.

Card 5/8

KISIL, I. M.; DUBOVSKIY, E. G.; KAYAZEV, A. F.; GERABOVA, L. A.; GLAZKOV, Yu. Yu.

"The Role of Critical Experiments in Designing the First Atomic Power Station and the Beloyarsk Atomic Power Station."

Report presented at the IAEA Symposium on Exponential and Critical Experiments, Amsterdam, Netherlands, 2-6 Sep 63.

GLAZKOV, Yu.Yu.; DUBOVSKIY, B.G.; ILYASOVA, G.A.; KOZLOV, V.I.; SMELOV, V.V.;
SHARAPOV, V.N.

Measurement of slow neutron spectra on the physical test stand
of the reactor of the I.V. Kurchatov Atomic Power Plant at
Beloyarskoye. Atom. energ. 15 no.6:481-485 D '63.
(MIRA 17:1)

BOILNITSYN, Ye. Ya.; KWIROV, A. G.; GLAZKOV, Ye. Ya.

"The study of neutron termination in water and graphite-water reactor lattices."

report submitted for int'l conf. on the theory of atomic energy, Moscow, 31 Aug- 6 Sept 64.

3/17/03/00/00010020
R052/1101

AUTHORS: Blyum, I. A., Glazkova, A. F.

TITLE: The methods of determining selenium and tellurium in ores

PERIODICAL: Referativnyy zhurnal, Estellurgiya, no. 3, 1968, 3, abstract PER
(V sb. "Khim., fiz., khim. i spektr. metody issled. rud i rask. i
rasseyan. elementov", Moscow, Gosgeoltekhizdat, 1968, 1-18)

TEXT: At a separated quantitative determination of Se and Te, the weighed
portion of ore is decomposed with HNO_3 . To oxidize Se, KI is used. 5 - 6 ml of
 HNO_3 is left, the volume is brought by adding water to 5-8 ml, hydrazine
chloride is added and the whole is left overnight. The Se residue is filtered
off, dissolved and the Se content is determined by the photocolometric method.
Fe is precipitated in the filtrate by Sn chloride, the residue is filtered off
and the Fe content is determined by the photocolometric method.

L. Vorob'yeva

[Abstracter's notes: 1) Complete translation.
2) The paper is supposed to deal with the determination of
tellurium (Te) but the reviewer is talking throughout about
iron (Fe), which is probably a misprint.]

Card 1/1

ANDREYEV, K.K.; GLAZKOVA, A.P.

Theory of anti-firedamp action. Doklady Akad. Nauk S.S.S.R. 86, 801-3 '52.
(CA 47 no.19:10229 '53) (MLRA 5:11)

1. D.I.Mendeleev Chem.-Technol. Inst., Moscow.

GLZ - 1/2, st. p

Category: USSR

B-9

Abs Jour: Zh-Kh, No 3, 1957, 7557

Author: Andreyev, K. K. and Glazkova, A. P.
Institution: Academy of Sciences USSR

Title: On the Effect of the Decomposition Products and Some Impurities on the Thermal Decomposition of Nitroglycerine

Orig Pub: Dokl AN SSSR, 1955, No 2, 286-289

Abstract: It has been shown by means of a membrane-type glass manometer that the decomposition of nitroglycerine (I) which has been purified of volatile impurities (water, etc.) is not accelerated by the presence of large amounts of decomposition products. When I contains water, a sharp acceleration of the decomposition is observed after a certain induction period (IP). The authors explain this acceleration by the hydrolysis of nitrocellulose, which is cata-

Card 1/2

13

Category: USSR

B 9

Abs Jour. Zh Kh. No 3, 1957, 7557

lyzed by the acid decomposition products of I, and the subsequent oxidation reactions. The addition of acids to I markedly decreases the IP. Partly decomposed I, after washing with water, reacts at the same rate as fresh I. The water which is formed also catalyzes the decomposition. The removal of the decomposition products by the application of suction does not completely suppress the catalyzing action. The addition of HNO_3 and of glyceridinitrate to I catalyzes the decomposition; in the latter cases, however, the reaction rate increases only after a considerable IP. The effect of water and acids described above is also observed in the case of nitroglycol and (under certain conditions) in the case of nitrocellulose.

Card 2/2

14.

GLAZKOVA, A.P.

✓ The influence of decomposition products and of some impurities on the thermal nitroglycerin decomposition. K. K. Andrey and A. P. Glazkova (D. I. Mendeleev Military Chemical Institute, Moscow, U.S.S.R.). *Dokl. Akad. Nauk SSSR*, 103, 286-287 (1955). Nitroglycerin decomps. in an auto-catalytic reaction in which gaseous products are formed; auto-catalysis is the more evident the larger the ratio of the mass of nitroglycerin to the vol. of the vessel. When nitroglycerin is carefully washed with water, it decomps. without auto-acceleration at much higher velocities and at lower temps. On addn. of H₂O, decomps. then rapidly, then drops, and rises again at a more rapidly accelerating pace. This is attributed to soln. of the gaseous decompn. products in water with the formation of HNO₃, and the catalytic action of the acid formed. HNO₃, and especially H₂SO₄, catalyze decompn., the latter particularly strongly because it is nonvolatile. The addn. of substances combining with HNO₃ and HNO₂ formed, e.g. diphenylamine, prevents the acid action. Nitroglycol and occasionally nitrocellulose behave similarly. W. M. Sternberg

RM [signature]

SC7726-52-9-3/57

AUTHORS: Andreyev, K. K., Glazkova, A. P., Marina, B. L., Svatlov, B. S.

TITLE: The Thermal Decomposition of Nitro esters (Teplovicheskii raspad nitroestirov) I. Investigation of the Kinetics of the Decomposition of Nitroglycerin and Nitroethyl alcohol according to the Manometric Method (I. Issledovanie kinetiki raspada nitroglitserina i nitroetilolova manometricheskim metodom)

PERIODICAL: Zhurnal Fizicheskoy khimii, 1958, Vol. 32, Nr 8, pp. 1726-1730 (USSR)

ABSTRACT: In the introduction the authors mention the investigations already carried out in this field and explain them; the papers by Robertson (Ref 1), Will (Vill) (Ref 2), S. E. Roginskiy et al. (Ref 4), and A. Ya. Apin, O. M. Todor and Yu. B. Kharitch (Ref 7) are mentioned. As the high temperature-coefficient of the decomposition rate of nitroglycerin does not depend on a high resistance of its molecule but on the heterogeneity of the course of decomposition a further investigation of this thermal decomposition is of special interest under simple conditions. It is interesting. A glass manometer with a thin-walled crescent-shaped glass membrane was used for the present experiments. The

Card 1/3

SCW 76-32-5-5/37

The Thermal Decomposition of Nitro Esters. I. Investigation of the Kinetics of the Decomposition of Nitroglycerin and Nitroethylacetamide by the Manometric Method

Investigations in the paper under review were carried out at 140, 150, and 165° and the maximum limit values of m/v were calculated according to the data of Brainer (ref. 1). It is assumed that in the thermal decomposition of nitroglycerin at least two macroscopic reaction stages exist as far as could be observed; also a reduction of the nitrogen dioxide to the oxide may take place. Thus, the rate of gas formation does not vary with time in strict accordance with an equation of a first order reaction. In the case of nitroethyl a similar result was obtained, with the difference that this process proceeded more quickly in the beginning. Experiments carried out in the liquid phase at small m/v and at temperatures of from 80 to 165° yielded values agreeing with those obtained by Robertson, although the intermediates were not removed. The decomposition in the liquid phase differs from that in the gas phase by the character of the $p = f(t)$ curves and the absolute value of the initial rate of gas formation. The effect of the decomposition products on the decomposition was investigated. Those with nitrogen dioxide were carried out by L. Ye. Tsubaknovskaya, and those with water by

Card 2/3

SOV/76-30-8-5/37

The Thermal Decomposition of Nitro Esters. I. Investigation of the Kinetics of the Decomposition of Nitroglycerin and Nitroethyl Acetate by the Manometric Method

G. N. Bupalov, student. Then the author thanks N. K. Emanuel'. There are 10 figures, 2 tables, and 12 references, 6 of which are Soviet.

ASSOCIATION: Khimiko-tekhnologicheskii institut im. D. I. Mendeleeva, Moskva (Institute of Chemical Technology imeni D. I. Mendeleev, Moscow)

SUBMITTED: January 13, 1957

Card 3/3

89:75

S/076/61/035/002/013/015
B107/3220

//5100

AUTHORS: Andreyev, K. K., Glazkova, A. P., and Tereshkin, I. A.
(Moscow)

TITLE: The influence of pressure on the burning of liquid explosives

PERIODICAL: Zhurnal fizicheskoy khimii, v. 35, no. 2, 1961, 426-430

TEXT: The study concerns the combustion of nitroalcohol in a glass tube of 3-4 mm diameter at pressures of up to 150 atm. The rate of combustion increases slowly up to about 20 atm pressure in proportional to the pressure: $u_M = 0.048 p$; then it rises much quicker: $u_M = -7.5 + 0.518 p$ (u_M in $\text{g/cm}^2 \text{ sec}$; p in kg/cm^2) (Fig. 1). This higher rate is due to turbulent intermittent burning. The aim of the present investigation was to study the zone of transition to intermittent burning. The fact that the higher rate of combustion depends on the turbulence of the combustion front and not only on the increased amount of heat was proved by tests with gelatinous nitroglycol: Throughout the pressure range investigated, a mixture of 97% nitroglycol and 3% Kolloxoline showed a uniform and slow increase of the combus-

Card 1/3

89576

S/O76/61/035/002/013/015
B107/B220

The influence of pressure ...

tion rate with pressure: $u_M = 0.075 + 0.0315$ (Fig. 2). The combustion products of nitroglycol are NO, CO, CO₂ (approximate ratio 7:1), slight amounts of methane, and possibly formaldehyde. Above a certain pressure - about 10 atm - a secondary flame appears due to the final combustion of NO. The distance between the secondary and primary flames is 18 mm for pure nitroglycol, $p = 12$ atm, and an internal tube diameter of 5 mm - 18 mm. This distance decreases rapidly with increasing pressure: $l = l_0 p^{-1.05}$ (Fig. 6)

For gelatinous nitroglycol, the distance is shorter. For pure nitroglycol, however, this distance begins to vary already at 16-20 atm pressure. Photographs taken with a high-speed camera and a photorecorder have shown that these variations may be regular or irregular. Finally, it is stated that the behavior of the secondary flame does not follow the theory of Ya. B. Zel'dovich and is, thus not decisive for the burning of the liquid. The tendency of the products of combustion to create a secondary flame is attributed not only to thermal but also to more complicated phenomena. According to studies made by I. I. Polyakov, a secondary flame will appear even at lower pressures when tubes of larger diameters are used. The au-

Card 2/4

The influence of pressure ...

S/C76/61/025/002/C13/015
3107/B22C

thors thank S. V. Chuyko for making available some illustrations of his diploma thesis. A paper of A. F. Belyayev and L. D. Komkova is mentioned. There are 13 figures and 1 Soviet-bloc reference.

ASSOCIATION: Akademiya nauk SSSR Institut khimicheskoy fiziki (Academy of Sciences USSR, Institute of Chemical Physics)

SUBMITTED: June 25, 1959

Legend to Fig. 1: (x) p in kg/cm^2 ; (y) u_M in cm. Pressure dependence of the rate of combustion of liquid nitroglycol.

Legend to Fig. 2: (x) p in kg/cm^2 ; (y) u_M in cm; (1) liquid nitroglycol; (2) gelatinous nitroglycol.

Legend to Fig. 6: (x) p in kg/cm^2 ; (y) l in mm; variation of the distance between primary and secondary flames as dependent on pressure: (1) liquid nitroglycol; (2) gelatinous nitroglycol. The zone of intermittent burning is indicated by a broken line.

Card 3/4

11.6300

26345
S/076/61/035/007/C-6/019
B132/B220

AUTHORS: Glazkova, A. P., and Tereshkin, I. A.

TITLE: Pressure dependence of the combustion rate of explosives

PERIODICAL: Zhurnal fizicheskoy khimii, v. 35, no. 7, 1961, 1622-1628

TEXT: The pressure dependence of the combustion rate was studied in a wide pressure range. Trotyl, picric acid, tetryl, Hexogen, Ten, and some mixtures such as Amatol 80:20, nitro-glycerin powder and black powder, and mixtures of ammonium perchlorate with several fuels were tested. Combustion was studied in bombs at constant pressures of 350 and 1000 atm. These bombs were designed by the Institut khimicheskoy fiziki AN SSSR (Institute of Chemical Physics AS USSR). The explosive was pressed into columns of organic glass of 7 mm diameter. Ignition was effected by means of a nichrome coil in nitrogen atmosphere. The combustion process was photographed on the moving film of a photographic recorder. The combustion rate was calculated from the equation $u_m = (L \cdot d \cdot \rho / k)$, where u_m is the mass velocity during combustion, L the circumference of the

Card 1/3

26345
S/076/61/035/007/0.6/0.9

Pressure dependence of the combustion . . . B132/E220

recording drum, n the speed of the drum, α the inclination of the combustion front to the horizontal, ρ the specific density of the specimen, and k the reduction of the specimen on the film. Accuracy was $\pm 5\%$. With trotyl and picric acid, the combustion rate increased linearly with pressure from minimum up to 1000 atm. With tetryl, $u_m = 0.04 - 0.014p$ holds

in the range of 250-1000 atm, whereas $u_m = 0.663p^{0.695}$ holds below 250 atm.

The combustion rate of Hexogen is much lower, and shows considerable variation above 200 atm. The combustion rate of Ten increases linearly in the range of 16-750 atm. In the case of Dynal, the combustion rate above 1000 atm increases faster than linearly with pressure. The combustion rate of nitro-glycerin (26%) powder increases with pressure according to the relation $u_m = 0.12 + 0.158p^{0.95}$ up to 50 atm. From 50-1000

atm, $u_m = 0.62 + 0.00926p$. For Amatol 80:20, the increase was a little slower than linear in the range of 150-300 atm. $u_m = 0.58 + 0.00554p$ holds

as from 40 atm. Gunpowder no. 1 was used in tests with black powder. The equation $u_m = Bp^V$ was derived for pressures between 10 and 1000 atm. The Card 2/4

Pressure dependence of the combustion ...

26345
S/076/61/035/007/016/019
B132/B220

values of coefficients A, B, and ν are tabulated for all substances tested; moreover, the combustion rates at 100 atm, and the combustion temperatures calculated. Professor K. K. Andreyev is thanked for his interest and assistance. A. P. Bakayev is mentioned. There are 14 figures, 1 table, and 4 references: 3 Soviet-bloc and 1 non-Soviet-bloc.

ASSOCIATION: Akademiya nauk SSSR, Institut khimicheskoy fiziki AN SSSR
(Academy of Sciences USSR, Institute of Chemical Physics
AS USSR)

SUBMITTED: December 25, 1959

Table. Values of coefficients A, B, and ν for a number of explosives.
Legend: (A) Explosive; (B) pressure range for which the equation holds, atm; (C) combustion rate at 100 atm; (D) combustion temperature T, °K; (E) trotyl; (F) picric acid; (G) tetryl; (H) Hexogen; (J) Ten; (K) Dyna; (L) nitro-glycerin 28% powder; (M) black powder; (N) Amatol 80:20. ✓

Card 3/4

ANDREYEV, K.K.; GLAZKOVA, A.P.; TERESHKIN, I.A.

Effect of pressure on the burning of liquid explosives. Zhur.
fiz. khim. 35 no.2:426-430 F '61. (MIRA 16:7)

1. Institut khimicheskoy fiziki AN SSSR.
(Explosives) (Combustion)

GLAZKOVA, A.P. (1941-)

Effect of pressure on the deflagration rate of ammonium perchlorate. PMTF no. 6:121-125 (3-0) (63). (MIRA 16:11)

1. Institut Khimicheskoi Fiziki, Akad. Nauk SSSR.

L 10533-63

EPR/EPF(c)/EWT(m)/BDS--APPTC/RPL--Pb-1/Pr-L...BII-2/

RM/WW/JW/JWD/H

ACCESSION NR: AP3000421

S/0076/63/037/005/1119/1123

AUTHOR: Glazkova, A. P.

78
72

TITLE: The effect of a liquid layer in the combustion of composite systems

SOURCE: AN SSSR. Zhurnal fizicheskoy khimii, v. 37, no. 5, 1963, 1119-1123

TOPIC TAGS: combustion of composite explosives, burning rate, pressure, ammonium perchlorate, potassium perchlorate, paraffin wax, triethylene glycol dimethacrylate

ABSTRACT: The role of a molten oxidizer and combustible layers formed in the combustion of composite explosives has been studied. Ammonium perchlorate or potassium perchlorate was mixed in stoichiometric proportions with low-melting-point combustibles (monomeric triethylene glycol dimethacrylate, paraffin wax) or with nonmelting combustibles (polymerized triethylene glycol dimethacrylate, coke, cellulose, naphthalene, urotropine). Mixtures with a particle size of less than 250 μ were compacted in plexiglass tubes 7 mm in diameter, and the burning rates at pressures ranging from atmospheric to 350 atm were determined photographically in a nitrogen-filled constant-pressure bomb. The burning-rate versus pressure

Card 1/32

L 10533-63

ACCESSION NR: AP3000421

3

curves showed that mixtures of ammonium perchlorate with liquid or low-melting combustibles burn faster and mixtures with nonmelting combustibles burn slower than the perchlorate alone. Mixtures of potassium perchlorate, which forms a molten layer, with nonmelting and melting combustibles burned at about identical rates. In other tests, mixtures of ammonium nitrate with monomeric and polymeric methacrylate burned at the same rate at 350-1000 atm. The experimental results are explained on the basis of the following mechanism: In the presence of a molten combustible layer the oxidizer particles are covered with the melt, which increases their reactivity and therefore the combustion rate. The presence of the combustible melt eliminates the buffer flame which is formed by decomposition of the oxidizer, and therefore the zone of maximal temperature is shifted to the surface of the condensed phase. Further experiments with ammonium nitrate of less than 250 μ and 1--10 μ in particle size showed that in the presence of a melting combustible the grain size has little effect on the combustion rate, but does affect it in the presence of nonmelting combustibles. Previous studies are also discussed which showed that in the combustion of mixtures of ammonium perchlorate and paraffin wax, the burning rate increased exponentially with pressures up to 300 atm and linearly at more than 300 atm. "The author considers it her pleasant duty to express thanks to K. K. Andreyev and V. K. Bobolev, in whose laboratory the experiments were set up, and also to her coworkers L. G. Bolkhovitinov and A. D. Margolin for their observations."

Card 2/2

L 13332-63

EPA/EPR/EPF(c)/EWT(m)/BDS/ES(s)-2 ABDC/AFPC/AFGT/

RPL/SSD Paa-4/Ps-4/Pr-4/Pt-4 RM/WW/EM-2/JW/JW/JWD/H

ACCESSION NR: AP3003856

S/0020/63/151/003/0604/0607

AUTHOR: Bobolev, V. K.; Glazkova, A. P.; Zenin, A. A.; Luyppanik, G. I.

90
88

TITLE: Temperature profile in ammonium perchlorate combustion

SOURCE: AN SSSR. Doklady*, v. 151, no. 3, 1963, 604-607

TOPIC TAGS: ammonium perchlorate, temperature profile, flame temperature, surface temperature, condensed phase, gas phase, pressure effect, burning rate, heat release

perchlorate combustion

ABSTRACT: The anomalous combustion pattern of ammonium perchlorate at pressures above 150 atm has prompted a study of the temperature profile of the condensed and gas phases in the combustion process. Flame-temperature measurements were carried out by the method of thin thermocouples developed by A. M. Zelin. Compressed samples of ammonium perchlorate were held at a constant pressure within the 30-350-atm range in a nitrogen atmosphere. Simultaneous photorecording of the burning rate and combustion pattern and oscillographic recording of temperature were provided. The recorded oscillograms and derived temperature profiles

Card 1/3

L 13332-63

ACCESSION NR: AP3003856

showed two distinct combustion patterns: a stable one within 40--150 atm and an unstable one within the 160--350 atm. The region of unstable combustion was characterized by temperature fluctuations with a high (up to 500C) amplitude in the gas phase, followed by a leveling off of temperature at about 2700C, which was assumed to be also the temperature at the surface. The surface temperature (T_g) was determined either indirectly from the maximum heat release in the condensed phase or directly by a method proposed by P. F. Pokhil (Sborn. Fizika vzry*va, no. 4, 1955 and no. 2, 1956). The increase in overall heat release with increasing pressure observed within the region of stable combustion was attributed in part to a simultaneous increase in heat release in the gas phase and in part to a change in the mechanism of chemical reactions. The heat release in the condensed phase, and hence T_g , decreased with increasing pressure and approached the temperature of phase transition within the range of unstable combustion. The existence of a heat barrier (80 cal/g) between the two combustion regions was determined from the identity of the experimental heat release at 150 atm in the condensed phase and the calculated amount of heat required to bring the condensed phase to 270C. Heat absorption in the phase transition might be responsible for the decrease in burning rate which leads to flame extinction. The surface temperature in the 50--150 atm pressure range was found

Card 2/3

L 13332-63

ACCESSION NR: AP3003856

to be relatively low (300—430C), which indicates a heat flow and hence diffusion of molecules and free radicals from the flame zone towards the surface. Activated combustion products are assumed to act as catalysts of thermal decomposition on the perchlorate surface. The assumption is extended to the combustion of any condensed system in which heat flows from the gaseous reaction zone toward the surface. The article was presented by Academician Ya. B. Zel'dovich on 9 April 1963. Orig. art. has: 4 figures.

ASSOCIATION: Institut khimicheskoy fiziki Akademii nauk SSSR (Institute of Chemical Physics, Academy of Sciences SSSR)

SUBMITTED: 31Mar63

DATE ACQ: 15Aug63

ENCL: 00

SUB CODE: CH

NO REF SOV: 006

OTHER: 004

Card 3/3

ACCESSION NR: AP4041206

S/0207/64/000/003/0153/0158

AUTHORS: Bobolev, V. K. (Moscow); Glazkova, A. P. (Moscow); Zenin, A. A. (Moscow);
Loypunskiy, O. I. (Moscow)

TITLE: A study of the temperature distribution in the combustion of ammonium perchlorate

SOURCE: Zhurnal prikladnoy mekhaniki i tekhnicheskoy fiziki, no. 3, 1964, 153-158

TOPIC TAGS: temperature distribution, combustion rate, pressure effect, flame temperature, grain effect, phase change, decomposition, point thermocouple, sublimation, condensation, combustion stability, heat liberation, oscillograph H 700

ABSTRACT: Studies of the combustion of preheated ammonium perchlorate at below-atmospheric pressure show that the combustion rate is limited by the equilibrium endothermic decomposition of NH_4ClO_4 to NH_3 and HClO_4 . A zone combustion treat-

ment of burning indicated, however, that the decomposition was exothermic. The point thermocouple method, developed by A. A. Zenin (Izucheniye raspredeleniya temperatury* pri goronii kondensirovannykh veshchestv. Dissertatsiya, Moscow, 1962) was used in this paper to study the temperature distribution of

Card 1/3

ACCESSION NR: AP4041206

ammonium perchlorate combustion. Two p-type thermocouples, W-Re (5 and 20%Re) with diameters of 15 and 30 μ and a thickness of 3.5 and 7 μ respectively, were used. The 7-mm samples of unfiltered perchlorate (pressed to a density of 1.93-1.94g/cm³) were treated over the pressure range 40-350 atmos of nitrogen. The thermocouples were impressed in the samples at a pressure of 3000-3500 kg/cm². Maintaining the pressure for 15-20 minutes produced transparent samples. The temperature distribution was recorded on a loop oscillograph H-700, and the speed and character of combustion were photographed. It was discovered that at the end of combustion there was a temperature fluctuation (50 msec and 500-1000C). The flame temperature fluctuation and plateau agreed well with the decreased brightness in the photographs, but complete examination of the oscillogram for unstable burning was not possible. This would require more precise recording of the fluctuation of the burning rate (perhaps with high-speed motion pictures). In some cases the burning was extinguished. Temperature profiles were obtained from 40-350 atm, which showed the presence of 2 combustion schemes for ammonium perchlorate, stable (40-150 atm) and unstable (160-350 atm). Abnormalities were discovered in the relation of the surface temperature and heat liberation (in the condensation phase) to the pressure. Assumptions were made concerning; 1) the variation of the ammonium perchlorate combustion mechanism with the growth of pressure; 2) the qualitative effect of the products passing from the reaction

Card 2/3

ACCESSION NO: AP4041206

zone in the gas phase to the surface by gasification of the condensation phase. An hypothesis was proposed concerning the reason for the decrease in the ammonium perchlorate combustion rate with an increase in pressure above 150 atm. An important discrepancy was established between the kinetic thermal decomposition and the kinetic gasification of perchlorate with combustion. Orig. art. has: 6 figures.

ASSOCIATION: none

SUBMITTED: 15Apr63

SUB CODE: GC

NO REF SOV: 004

ENCL: 00

OTHER: C05

Card 3/3

1950-1951

...

...

GLAZKOVA, E.L.

Crystallization of glucose and sodium chloride primary compounds
from hydrochloric wood hydrolyzates. Sher. Izv. NII Kh. 12:165-171
'64. (MIRA 18:3)

GLAZKOVA, G.

Balancing income and expenditures by districts. Dën. i kred. 17
no.8:59-60 Ag '59. (MIRA 12:11)

1. Starshiy kreditnyy inspektor Sverdlovskoy oblastnoy kontory Gosbanka.
(Sverdlovsk Province--Banks and banking---Accounting)

5.2500
5.4500(B)

S/O20/60/132/03/43/066
B004/B007

AUTHORS: Spitsyn, Vikt. I., Academician, Torchenkova, Ye. A.,
Glazkova, I. N.

TITLE: The Influence of the Radioactive Radiation¹⁹ of a Solid on
the Processes of Its Dissolution

PERIODICAL: Doklady Akademii nauk SSSR, 1960, Vol. 132, No. 3,
pp. 643-645

TEXT: The authors investigated the solubility of $BaSO_4$ which was traced with S^{35} . They describe the production of $BaSO_4$, the specific surface of which was determined by means of a microscope and an electron microscope. The particles had a size of $2.7-8.1\mu$. Furthermore, the activity of precipitate and solution was measured in intervals of time. Fig. 1 shows the kinetics of $BaSO_4$ dissolution of different activities at $20^\circ C$. $BaSO_4$ was obtained by mixing equivalent quantities of 0.1 N solutions of $BaCl_2$ and Na_2SO_4 . With a specific radioactivity of the preparation of 0.7-1.0 milli-
Card 1/3

The Influence of the Radioactive Radiation of
a Solid on the Processes of Its Dissolution

S.020/60/132/03/43/066
B004/B007

curie/g considerable oversaturation was observed, which decreased after 25 h. In the case of preparations with 9-20 millicuries/g the concentration of the dissolved BaSO_4 increased proportionally with time. The solubility of BaSO_4 is increased by an excess of Na_2SO_4 , but especially by an excess of BaCl_2 (Fig. 2). If instead of Na_2SO_4 a 0.1 N H_2SO_4 is used for the production of BaSO_4 , solubility decreases (Figs. 3,4), but the kinetics of solubility shows the same phenomena as represented in Fig. 1. The authors explain this phenomena as being due to β -radiation, by which the electric double layer at the interface is influenced. This influence acts in a similar way on the dissolution as the ion strength of the solution. The occurrence of a maximum is ascribed to a change in the interaction between β -particles and the substance with an increased number of β -particles. There are 4 figures and 14 references: 9 Soviet, 1 Austrian, 1 French, 1 German, and 1 Dutch.

ASSOCIATION: Institut fizicheskoy khimii Akademii nauk SSSR (Institute of
Physical Chemistry of the Academy of Sciences, USSR)

Card 2/3

The Influence of the Radioactive Radiation of
a Solid on the Processes of Its Dissolution

S/O20/60/132/03/43/066
B004/B007

SUBMITTED: February 24, 1960

4

Card 3/3

SPITSYN, Vist.I., akademik; TORCHEMKOVA, Ye.A.; GLAZKOVA, I.N.

Process of solution of barium sulfate tagged with two radioactive indicators. Dokl.AN SSSR 133 no.5:1111-1112 Ag '60.

(MIRA 13:8)

1. Institut fizicheskoy khimii Akademii nauk SSSR.

(Barium sulfate) (Barium--Isotopes) (Sulfur--Isotopes)

ACCESSION NR: AT4013959

S/2659/63/010/000/0239/0246

AUTHOR: Arkharov, V. I.; Konev, V. N.; Nesterov, A. F.; Andrianovskiy, B. P.; Glazkova, I. P.

TITLE: Investigation of metal oxidation in sulfur-saturated air

SOURCE: AN SSSR. Institut metallurgii. Issledovaniya po zharoprochnym splavam, v. 10, 1963, 239-246

TOPIC TAGS: oxidation, sulfur, titanium chromium, maganese, cobalt iron, nickel, metal oxidation, transition element

ABSTRACT: The presence of sulfur in the air frequently leads to acceleration of the oxidation rate, and sometimes to dangerous accidents. The present paper describes the results of investigating the oxidation of Ti, Cr, Mn, Co, Fe and Ni in air containing two chemically active components: oxygen and sulfur. For this group of metals the importance of sulfur in oxidation increases from titanium to nickel. This is explained by the fact that the sulfur activity rises and the oxygen activity drops. The percentage of sulfur in the oxidation scale increases from 0.004% for titanium to complete sulfuration of all the nickel under the layer of NiO. This explains the brittleness of nickel during heat treatment in sulfur-containing media. The process of metal oxidation in sulfur-oxygen media corrobo-

Card 1/2

ACCESSION NR: AT4013959

rates the previously published opinions of the authors. Orig. art. has: 2 figures and 2 tables.

ASSOCIATION: Institut metallurgii AN SSSR (Institute of Metallurgy AN SSSR)

SUBMITTED: 00

DATE ACQ: 27Feb64

ENCL: 00

SUB CODE: MM

NO REF SOV: 011

OTHER: 002

Card 2/2

L 18102-63 EWP(q)/EWT(m)/BDS AFFTC/ASD JD/JG
ACCESSION NR: AP3004596 S/0126/63/016/001/0086/0090

61
60

AUTHORS: Konev, V. N.; Nesterov, A. F.; Glazkova, I. P.

TITLE: Study of the reaction diffusion in the systems "metal-gas mixture." 7.
Molybdenum - Silicon - Boron 16

SOURCE: Fizika metallov i metallovedeniye, v. 16, no. 1, 1963, 86-90

TOPIC TAGS: diffusion, ternary system, Mo-Si-B

ABSTRACT: Experimental results obtained in the investigation of the reaction diffusion in the system Mo-Si-B are discussed. The experiments were made at temperatures 800-1200C following the procedure described by A. F. Gerasimov, V. N. Konev, and N. P. Timofeyeva (FMM, 1961, 11, 596). It was established that a diffusive layer is formed in the system Mo-(B + Si) in the atmosphere $BCl_3 + SiCl_4 + H_2$. The layer consisted of phases with the structure Mo_2B_5 (to 1000C), and Mo_2B_5 with α -MoB (above 1000C). Apparently silicon participated in this process (the diffusion of boron was slow and the activation energy of boron diffusion had a greater value than it would have in the absence of Si). It was

Card 1/2

L 18102-63

ACCESSION NR: AP3004596

assumed that the diffusion in the systems Mo-B, Mo-Si, and Mo-B-Si proceeds due to the inward penetration of the component gas atoms through the space lattice of the layers formed. The basic reaction-front in such systems is the intraphasal boundary "case-metal." The comparison of the radii of Mo, B, and Si ($r_{\text{Mo}} = 1.40$; $r_{\text{B}} = 0.87$; $r_{\text{Si}} = 1.17 \text{ \AA}$ correspondingly) indicates the correctness of this hypothesis. Orig. art. has: 3 figures.

ASSOCIATION: Ural'skiy gosudarstvennyy universitet im. A. M. Gor'kogo (Ural State University)

SUBMITTED: 12Sep62

DATE ACQ: 27Aug63

ENCL: 00

SUB CODE: ML, PH

NO REF SOV: 022

OTHER: 009

Card 2/2

DANILOV, P.M.; KRAMAROV, A.D.; YEREMENKO, S.N.; GLAZKOVA, L.V.

Oxygen content and nonmetallic inclusions in steel with its
deoxidation by aluminum. Izv. vys. ucheb. zav.; Chern. met. 4
no. 8:48-55 '61. (MIRA 14:9)

1. Kuznetskiy metallurgicheskiy kombinat i Sibirskiy metallurgicheskiy
institut.
(Steel--Oxygen content) (Aluminum)

BLAZKOVA, H. A. J. Appl. Phys.-Math. Sci. (Mag) "Infrared Spectra
of Various Forms of Silicon." *Vysokaya Fizika*, 1972, 14, 1, 1-4. (Acad. of Sci.
USSR, Combined Journal of Institute of Physics, Institut of
Math. and Computer Technique and Dept. of Physics and
Semi-Conductors) OST Series (NL sup 11-61, 70).

L 38707-66 EWT(m)/T/EWP(t)/ETI LJP(c) JD/WW/JG/JWD/GE
ACC NR: AT6016861 (A) SOURCE CODE: UR/0000/65/000/000/0086/0092

AUTHOR: Pavlyuchenko, M. M.; Glazkova, N. I.

ORG: none

TITLE: Zinc carbonate decomposition in vacuo and in melts of alkali metal nitrates

SOURCE: Geterogennyye khimicheskiye reaktsii (Heterogenous chemical reactions).
Minsk, Nauka i Tekhnika, 1965, 86-92

TOPIC TAGS: nonferrous metal, zinc compound, reaction rate, thermochemistry, heat of decomposition, carbonate, activation energy, *alkali metal, nitrates*

ABSTRACT: The kinetics of thermal decomposition of $ZnCO_3$ was studied in vacuo and in a 58% KNO_3 +42% $LiNO_3$ melt in the 250°-280°C range. The object of the work was to verify the pertinent information in the literature. It was found that $ZnCO_3$ decomposition is a self-accelerating reaction and that its rate increases with increasing temperature. It was also found that at 280°C and at 250°C, the $ZnCO_3$ decomposition in the KNO_3 + $LiNO_3$ melt and in vacuo was 129 and 178 times greater, respectively than in vacuo in the absence of the melt. The dependence of the

Card 1/2

Card 2/2 *2/2*

BASHENINA, Natal'ya Viktorovna; GLAZKOVA, N.M., red.; LAZAREVA,
L.V., tekhn. red.

[Ecology of the common vole (*Microtus arvalis*) and some
characteristics of its geographical variability] Ekologiya
obyknovennoi polevki i nekotorye cherty ee geograficheskoi
izmenchivosti. Moskva, Izd-vo Mosk. univ., 1962. 308 p.
(MIKA 15:7)

(Field mice)

MIRISANFOVA, Yelena Nikolayevna; GLAZKOVA, N.M., red.; LAZAEVA,
L.V., tekhn. red.

[Theoretical problems in the variability of the human spine
and chest] Teoreticheskie voprosy izmenchivosti pozvonochnika
i grudnoi kletki cheloveka. Moskva, Izd-vo Mosk. univ., 1962.
52 p. (MIRA 15:7)

(SPINE) (CHEST)

SHOSTAKOVSKIY, M.F.; SKVORTSOVA, G.G.; DOMINA, Ye.S.; GLAZKOVA, N.F.

Some features of vinylindole chlorination in halogenation reactions.
Izv. AN SSSR, Ser. khim. no.3:529-531 '65. (MIRA 18:5)

1. Irkutskiy institut organicheskoy khimii Sibirskogo otdeleniya
AN SSSR.

... ..
... ..
... ..
... ..
... ..

KUZYAKINA, O., kand.tekhn.nauk; GLAZKOVA, S., inzh.

Partial replacement of the cement in concrete and reinforced
concrete elements with fly ash from burning brown coal at the
Aleksandrovskaya Thermal Electric Plant. Bud.mat.i konstr. 4
no.6:30-33 N-D '62. (MIRA 15:12)
(Ukraine—Fly ash) (Lightweight concrete)

GLAZKOVA, T.A., kandidat meditsinskikh nauk

Treatment of cholecystitis and cholangitis with antibiotics as related to the microflora of the duodenum. Sov.med.20 no.10:60-64 0 '56.

(MLRA 10:1)

1. Iz kafedry gospital'noy terapii (nauchnyy rukovoditel' prof. V.M.Karatygin) Sverdlovskogo meditsinskogo instituta.

(CHOLECYSTITIS, ther.

antibiotics, eff. of duodenal macroflora on indic.)

(ANTIBIOTICS, ther. use

cholecystitis and cholangitis, eff. of duodenal microflora on indic.)

(CHOLANGITIS, ther.

antibiotics, eff. of duodenal microflora on indic.)

(DUODENUM, microbiol.

eff. on indic. for antibiotic ther. in cholecystitis & cholangitis)

1. The first part of the document is a list of names and titles of the members of the committee. The names are listed in alphabetical order. The titles are listed in the order in which they appear in the document. The names and titles are as follows:

GLAZKOVA, T.S.

Comparative evaluation of the effect of biomycin and of other drugs
in the treatment of patients with dysentery. Trudy LSGMI 46:153-
161 '59. (MLA 13:11)

1. Kafedra infektsionnykh bolezney Leningradskogo sanitarno-
gigiyenicheskogo meditsinskogo instituta (nav. kafedroy - prof.
V.V.Kosmachevskiy).

(AUREOMYCIN)

(DYSENTERY)

SOKOLOVSKAYA, Ya.I.; KOZLOVA, A.A.; SMIENOVA, S.A.; KHYLOVA, O.M.;
GLAZKOVA, T.S.; ALEKSANDROVA, V.E.; KAPETANAKI, K.S.

Viacheslav Viktorovich Kosmachevskii; on his 75th birthday. Zhur.
mikrobiol., epid. i immun. 33 no.4:154-155 Ap '62. (MIRA 15:10)
(KOSMACHEVSKII, VIACHESLAV VIKTOROVICH, 1987.)

L 11877-67 EMT(1) SOTB DD/GD

ACC NR: AT6036311

SOURCE CODE: UR/0000/66/000/000/0085/0036

AUTHOR: Vakar, M. I.; Chernyakov, N. I.; Maksimov, I. V.; Glazkova, V. A.;
Acheyskiy, P. Ya. 20

ORG: none

TITLE: Moisture loss in the human organism at high altitudes [Paper presented at
the Conference on Problems of Space Medicine held in Moscow from 24 to 27 May 1966]SOURCE: Konferentsiya po problemam kosmicheskoy meditsiny, 1966. Problemy
kosmicheskoy meditsiny. (Problems of space medicine); materialy konferentsii,
Moscow, 1966, 85-86TOPIC TAGS: high altitude physiology, alpine acclimatization, hypoxia, human
physiology, perspirationABSTRACT: Moisture loss in man during exposures of several hours to high altitudes
(30,000 m and above) during pressure oxygen breathing was studied.

The subjects wore altitude compensating suits which did not prevent contact between the skin and the high vacuum and did not impede evaporation of moisture from the surface of the body and from underclothing. Water loss was calculated by weighing the subjects before and after the experiment. Decrease in temperature of the skin and underclothing was recorded with a thermocouple and served as an indirect index of evaporation intensity.

Card 1/2

L 11387-67

ACC NR: ATD66-111

The subjects were at rest in some experiments and performed physical work of medium difficulty in others.

It was found that during prolonged resting exposure to high altitudes moisture loss increases by 1.5 to 2 times (from 40-50g/hr to 70-120g/hr). This increase is due to increased evaporation from the skin in a rarefied atmosphere. Increased perspiration due to emotional tension was also sometimes seen.

Step test exercises caused still greater water loss (120 to 225 g/hr). Increased moisture loss at high altitudes was primarily due to the wearing of altitude equipment which hindered movement, as well as to rarefied atmosphere and emotional tension.

Skin temperature dynamics confirmed the intensification of evaporation from the body and underclothing at high altitudes. [W.A. No. 22; ATD Report 66-116]

SUB CODE: 06 / SUBM DATE: 00May66

Card 2/2 egk

ACC NR: AT6036531

SOURCE CODE: UR/0000/66/000/000/0122/0123

AUTHOR: Glazkova, V. A.; Maksinov, I. V.; Chornyakov, I. H.

ORG: nono

TITLE: Dynamics of blood oxygen saturation in man during excess pressure breathing at high altitudes [Paper presented at the Conference on Problems of Space Medicine held in Moscow from 24 to 27 May 1966.]

SOURCE: Konferentsiya po problemam kosmicheskoy meditsiny, 1966. Problemy kosmicheskoy meditsiny. (Problems of space medicine); materialy konferentsii, Moscow, 1966, 122-123

TOPIC TAGS: high altitude physiology, blood chemistry, human physiology, hypoxia, oxyhemography, blood oxygen saturation

ABSTRACT: Blood oxygen saturation during excess pressure breathing (150 and 180 mm Hg) at altitudes of 30000 m and higher with counterpressure altitude compensation was studied in man by the oxyhemograph method. Saturation level obtained during pure oxygen breathing on the ground was taken as 98 to 100%.

Above 12000 m, blood oxygenation depends on absolute intrapulmonary pressure which in turn determines alveolar pO_2 . At an intrapulmonary pressure ≈ 150 mm Hg (alveolar $pO_2 \approx 60$ mm Hg), blood oxygen satura-

Card 1/3

ACC NR: AT6036531

tion varied between 84% and 88% at all altitudes from 12000--36000 m. At a higher intrapulmonary pressure of 180 mm Hg (alveolar $pO_2 \approx 90$ mm Hg), oxyhemoglobin rose to 90% -- 95%.

Breathing air at 3000 m gives an alveolar pO_2 about equal to that obtained by breathing oxygen without excess pressure at 12000 m with an absolute intrapulmonary pressure of 150 mm Hg at altitudes above 12000 m. Nonetheless, blood oxygen saturation was lower (76% to 78%) while breathing air at 3000 m than while breathing oxygen at 12000 m and above (84% and 86%, respectively). It is suggested that the exclusion of nitrogen from the alveoli during oxygen breathing at 12000 m and above improves oxygenation of the blood.

Conversation or counting aloud produced a 3% to 5% increase in blood oxygen saturation provided speech activity did not interfere with respiration rhythm and provided the subject did not speak too softly and slowly. This increase is due to hyperventilation accompanying active speech and not to enhanced cerebral blood circulation due to mental effort.

During light physical exercise, saturation plunged to 74% to 78%, the rate of decrease depending on intensity of the exercise and impairment of external respiration.

Card 2/3

ACC NR: AT6036531

On longer exposure to the maximum altitude, oxyhemoglobin gradually decreased by 4% to 6% though the absolute intrapulmonary pressure did not change. This decrease is not yet explained.

In two cases in which presyncope states developed, oxyhemoglobin fell gradually to 70% or 60%, then increased sharply to 95% or 96%. These disturbances were evidently due not to hypoxic hypoxia, but to circulatory hypoxia.

Recordings of linear blood flow velocity and the endurance of voluntary apnea showed these indices also to depend on oxyhemoglobin percents.

[N. A. No. 22; ATD Report 66-116]

SUB CODE: 06 / SUBM DATE: 00May66

Card 3/3

GLAZKOVA, V.L., mladshiy mashinnyy sotrudnik

Simplified methods for the analysis of the physico-mechanical
properties of twisted yarn. Tekst. prom. 23 no.6:32-34 Ja '63.
(MIRA 16:7)

1. Tsentral'nyy nauchno-issledovatel'skiy institut khlopkato-
bunazhnoy promyshlennosti (TSNKhBI).
(Yarn--Testing)

GLAZKOVA, V.N., akusherka

Prevention of toxicoseptic diseases in the newborn. Fel'd. i akush.
21 no.9:29-32 S '56. (MLRA 9:10)

1. Rodil'noye otdeleniye zheleznodorozhnoy bol'nitay, stantsiya
Smolensk.

(INFANTS (NEWBORN)--DISEASES)

MAVCHENKO, Nikolay Antonovich; LEBEDEV, A.M., nauchn. red.; LAMONOSOVA,
Ye.I., red.; BESMYSLOVA, L.M., tekhn. red.

[Electric tool for assembly and repair work] Elektrifitsirovannyi instrument dlia montazhnykh i remontnykh rabot.
Moskva, Proftekhizdat, 1963. 169 p. (KIFA 44:1)

GLAZOVA, V.V.; KURNAKOV, N.N.; LYASHCHENKO, A.B.

Investigating atomic interaction in titanium-zirconium-tin
solid solutions. Fiz. met. i metalloved. 12 no.5:656-659 N
'61. (MIRA 14:12)

1. Institut metallurgii AN SSSR imeni A.A.Baykova i Institut
metallokeramiki i spetsial'nykh spalvov AN SSSR.
(Titanium-zirconium-tin alloys---Testing)
(Crystal lattices)

GLAZOVA, V.V. (Moskva); KURNAKOV, N.N. (Moskva) [deceased]

Creep of titanium-zirconium-tin alloys. Izv. AN SSSR. Otd. tekhn. nauk.

Met. i gor. delo no.1:161-167 Ja-² '63. (MIRA 16:3)

(Creep of metals) (Titanium-zirconium-tin alloys--Testing)

USSR / General and Specialized Zoology. Insects. Pests of Food
Stuffs. P

Abstr Jour : Ref Zhur - Biologiya, No 16, 1958, No. 73545
Author : Glazkova, Ye. B.
Inst : North Osetian State Agricultural Experimentation
Station
Title : Aerosol Method for Disinfecting Granaries From Pests
Orig Pub : Byul. nauchno-tekhn. inform. Sev.-Osetinsk. gos. s.-kh.
opyt. st., 1957, No 1, 43-45
Abstract : No abstract given

Card 1/1

25

ZHEBIN, Moisey Isaakovich; SHAMIRGON, S.A., nauchnyy red.; IONOV,
V.N., red.; GLAZKOVA, Ye.I., red.; DORODNOVA, L.A., tekhn.
red.

[Molder employed in manual molding] Formovshchik ruchnoi for-
movki. Moskva, Proftekhizdat, 1962. 294 p. (MLRA 16:1)
(Molding (Founding))

SIL'CHENKO, Serafim Semenovich; ZUBOV, V.T., inzh., nauchnyy red.;
GLAZKOVA, Ye.I., red.; NESMYSLOVA, L.K., tekhn. red.

[Mechanization and automation of fitting and assembling work]
Mekhanizatsiia i avtomatizatsiia slesarno-sborochnykh opera-
tsii. Moskva, Proftekhizdat, 1962. 147 p. (MIRA 16:4)
(Machine-shop practice) (Automation)

SLAVCHENKO, Nikolay Antonovich; LEDEEV, A.S., red.;
GLAZKOVA, Ye.I., red.; NESYMCOVA, L.K., tech. P.

[Electric tools for assembly and repair work] Elektrifitsirovannyi instrument dlia montazhnykh i remonta rabot.
Moskva, Proftekhizdat, 1963. 109 p. (1963)
(Power tools)

GLAZOVSKAYA, M. A.

Geochemical principles in the classification of natural
landforms. Vop. geog. no. 59:6-52 '62. (MIRA 16:1)

(Landforms--Ural Mountains--Classification)
(Geochemical prospecting)

IVANOV, K.I., red.; BELOTSERKOVSKIY, M.Yu., red.; BOLSHEV, N.N., red.;
GEDYMIN, A.V., red.; GLAZOVSKAYA, M.A., red.; GOLOVENKO, S.V.,
red.; ZVORYKIN, K.V., red.; IGNAT'YEV, G.M., red.; KUZNETSOV,
G.A., red.; LEBEDEV, N.P., red.; LEBEDEV, P.N., red.;
RAKITNIKOV, A.N., red.; SHEYNIN, L.B., red.; GREBTSOV, P.P.,
red.; YERFAKOV, M.S., tekhn. red.

[Accounting for and the evaluation of agricultural land]
Uchet i otsenka sel'skokhoziaistvennykh zemel'. Pod red. K.I.
Ivanova. Moskva, Izd-vo Mosk. univ., 1963. 385 p.

(MIRA 16:7)

(Farm--Valuation) (Soils--Classification) (Cadasters)

VITOSHINSKAYA, M.I., bibliograf; GEKKER, I.F., bibliograf; SHNEIDER, R.A., bibliograf; GLAZKOVSKAYA, Ya.A.; KLYASHTORNIY, S.G.; SOLOV'YEV, S.P., doktor geologo-mineral.nauk, red.; KULIKOV, M.V., kand. biolog.nauk, red.; PERLIN, S.S., red.izd-va; GUROVA, O.A., tekhn.red.

[Geological literature of the U.S.S.R.; a bibliographical year-book for 1954] Geologicheskaya literatura SSSR; bibliograficheskiy ezhegodnik za 1954 g. Moskva, Gos. nauchno-tekhn.izd-vo lit-ry po geol. i okhrane nedr, 1957. 185 p. (MIRA 12:1)

1. Moscow. Vsesoiuznaya geologicheskaya biblioteka.
(Bibliography--Geology)

VITOSHINSKAYA, M.I., bibliograf; GEKKER, I.F., bibliograf; SNEYDER, R.A., bibliograf; GLAZKOVSKAYA, Ye.A., bibliograf; KLYASHTORNYI, S.G., bibliograf; SOLOV'YEV, S.P., doktor geologo-minerolog. nauk, red.; KULIKOV, M.V., kand.biolog.nauk, red.; IVANOVA, A.G., tekhn. red.

[Geological literature in the U.S.S.R.; bibliographical year-book for 1955] Geologicheskaya literatura SSSR; bibliograficheskii ezhegodnik za 1955 g. Moskva, Gos.nauchno-tekhn.izd-vo lit-ry po geologii i okhrane nedr, 1959. 333 p. (MIRA 12:11)

1. Moscow. Vsesoyuznaya geologicheskaya biblioteka. 2. Vsesoyuznaya geologicheskaya biblioteka Vsesoyuznogo geologicheskogo nauchno-issledovatel'skogo instituta (for Vitoshinskaya, Gekker, Sneyder, Glazkovskaya, Klyashtornyy). (Bibliography--Geology)

BEREGOVSKIY, V.Ye.; VASILENKO, M.I.; VELLER, R.L.; VERBLOVSKIY, A.M.;
VERNER, B.F.; VOYDALOVSKAYA, Ya.N.; VOL'SKIY, A.N.; GLAZKOVSKIY, A.A.;
GRANOVSKIY, B.L.; GREYVER, N.S.; GUDIMA, N.V.; DOLGOCOLOVA, V.I.;
KARCHEVSKIY, V.A.; KOVACHEVA, Ya.B.; KUDRYAVTSEV, P.S.; LEBEDEV, A.K.;
LISOVSKIY, D.I.; LIKHNITSKAYA, Z.P.; MATVEYEV, N.I.; MEL'NITSKIY, A.H.;
MIRONOV, A.A.; MIKHEYEVA, A.A.; MURACH, N.N.; OKUL', A.B.; OL'KHOV, N.P.;
OSIPOVA, T.B.; PAVLOV, V.P.; ROTINYAN, A.L.; SAZHIN, N.P.; SEVRYUKOV, N.N.;
SIDOROV, P.M.; SOBOL', S.I.; KHYFETS, V.L.; TSEYNER, V.M.;
SHAKHNAZAROV, A.K.; SHEYN, Ya.P.; SHEREMET'YEV, S.D.; SHERMAN, B.P.;
SHISHKIN, N.N.; SHLOPOV, A.P.

Georgii Ivanovich Blinov. TSvet.met. 28 no.6:62 N-D '55.
(MIRA 10:11)

(Blinov, Georgii Ivanovich, 1911-1955)

SOV/137-58-7-14515

Translation from: Referativnyy zhurnal, Metallurgiya, 1958, Nr 7, p 83 (USSR)

AUTHOR: Glazkovskiy, A.A.

TITLE: The Current State and Outlook of Ore Supply in the Nickel and Cobalt Industry (Sostoyaniye i perspektivy rudnoy bazy nikel'evoy i kopal'tovoy promyshlennosti)

PERIODICAL: Materialy Soveshchaniya po vopr. intensiv. i usoversh. dobychi i tekhnol. pererabotki medno-nikelevykh i nikel'evykh rud. 1956 g. Moscow, Profizdat, 1957, pp 18-28

ABSTRACT: The USSR has the world's greatest total prospected Ni resources. Sulfide Cu-Ni ores represent 81% of the total reserves; silicates constitute the remaining 13.9%. The pure Co ores are negligible; 90% of the Co is obtained as a by-product of Ni recovery. Among the large sulfide ore occurrences, those of Noril'sk, Pechenga, and Monchegorsk are described. New major occurrences with high Cu, Ni, and platinoid contents have been discovered in recent years in the vicinity of Pechenga and Monchegorsk. Major new discoveries of oxidized Ni and Co ores have been made in the Southern Urals and the vicinity of Ufaley. An Ni deposit has been found in

Card 1/2

SOV/137-58-7-14515

The Current State and Outlook of Ore Supply (cont.)

Kirovograd Oblast' in the Ukraine, and another near Nikopol'.

L.P.

1. Nikopol' area -- 1970. 2. Nikopol' area -- 1970. 3. Nikopol' area -- 1970.
4. Nikopol' area -- 1970.

Card 2/2

GLAZKOVSKIY, A.A.; KRUTOV, G.A., nauchnyy red.; ZVEREV, L.V., nauchnyy red.; FATIS, T.I., red. izd-va; BYKOVA, V.V., tekhn. red.

[Industry's requirements as to the quality of mineral raw materials] Trebovaniia promyshlennosti k kachestvu mineral'nogo syr'ya; spravochnik dlia geologov. Moskva, Gos. nauchno-tekhn. izd-vo lit-ry po geol. i okhrane neдр. No.55.[Cobalt] Kobal't. Nauch. red. G.A.Krutov i L.V.Zverev. Izd.2., perer. 1961. 49 p. (MIRA 15:2)

L. Moscow. Vsesoyuznyy nauchno-issledovatel'skiy institut mineral'nogo syr'ya.

(Cobalt)

GLAZECVSEIY, Aleksandr Aleksandrovich; YERCHOV, A.D., glavnyy red.;
TUBBEV, I.N., zamestitel' glavnogo red.; KOGAN, G.B., red.;
GIBALIN, G.G., red.; KUPCHENOV, B.Ya., red.; MOISEVI, G.S., red.;
KOZHARITSKIY, K.L., red.; SMIRNOV, V.I., red.; SLOVAK, A.P.,
red.; TOBYANOV, A.T., red.; FISHKOVSKAYA, T.B., red.

[Nickel.] Nikel'. Moskva, Gospolitekhizdat, 1963. 181 p.
(Otsenka mostorozhdenii pri polskakh i razvedkakh, no. 30)
(MIRA 17:5)

Mineralogic investigation of copper ores of the Dzhetkazganakii deposit of the Casak A. S. S. R. (I. S. Yagovskii and V. A. Glazkovskii) *Izv. Akademiya Nauk Kazakhskoi SSR Seriya Fiziko-Matematicheskii Nauki* 1979, No. 1, p. 10-15.

The minerals of the enclosing ores are: quartz, siderite, orthoclase, oligoclase, albite, apatite, calcite and aluminous shale. The ores contain mainly primary sulfides such as chalcopyrite and bornite, secondary pyrrhotite, pyrite and tetrahedrite, while among the secondary sulfides only chalcocite is found. The samples contained iserrite, chalcopyrite, algodonite, with up to 12.4 and 3.0% of Cu in the first 2 minerals. Numerous photomicrographs are given. A. A. B.

