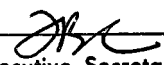

EXECUTIVE SECRETARIAT
Routing Slip

TO:		ACTION	INFO	DATE	INITIAL
1	DCI				
2	DDCI				
3	EXDIR				
4	D/ICS				
5	DDI	X			
6	DDA				
7	DDO				
8	DDS&T				
9	Chm/NIC				
10	GC				
11	IG				
12	Compt				
13	D/EEO				
14	D/Pers				
15	D/OEA		X		
16	C/PAD/OEA				
17	SA/IA				
18	AO/DCI				
19	C/IPD/OIS				
20					
21					
22					
		SUSPENSE	22 Oct		
			Date		

Remarks:
 Please prepare response for DCI's signature - forward through D/OEXA.

Executive Secretary
 18 October 1982
 Date

CHARLES H. PERCY, ILL., CHAIRMAN

HOWARD H. BAKER, JR., TENN.
JESSE HELMS, N.C.
S. I. HAYAKAWA, CALIF.
RICHARD G. LUGAR, IND.
CHARLES MC C. MATHIAS, JR., MD.
NANCY L. KASSEBAUM, KANS.
RUDY BOSCHWITZ, MINN.
LARRY PRESSLER, S. DAK.

CLAIBORNE PELL, R.I.
JOSEPH R. BIDEN, JR., DEL.
JOHN GLENN, OHIO
PAUL S. SARBANES, MD.
EDWARD ZORINSKY, NEBR.
PAUL E. TSONGAS, MASS.
ALAN CRANSTON, CALIF.
CHRISTOPHER J. DODD, CONN.

United States Senate

COMMITTEE ON FOREIGN RELATIONS

WASHINGTON, D.C. 20510

EDWARD G. SANDERS, STAFF DIRECTOR
GERYLD B. CHRISTIANSON, MINORITY STAFF DIRECTOR

Executive Registry
82-12541

DDI-8882-82

October 15, 1982

Mr. William J. Casey
Director, Central Intelligence
Washington, D.C. 20505

Dear Mr. Casey:

In the attached article published in this month's issue of Scientific American, Lynn R. Sykes and Jack F. Evernden state that their analysis of Soviet weapons tests seismic data leads them to conclude that the Soviets have abided by the 150 kiloton threshold provided for under the Threshold Test Ban Treaty. These writers also claim that using a relatively small seismic network within the Soviet Union, the United States could verify a comprehensive test ban with an extremely high degree of confidence.

I should appreciate having the Central Intelligence Agency's assessment of this article's conclusions, especially the above mentioned claims.

Sincerely,

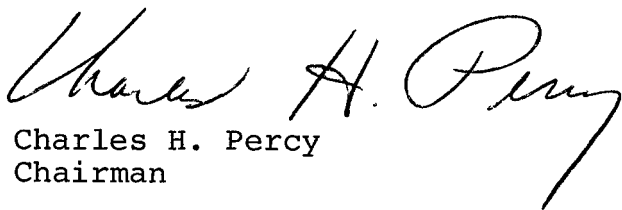
Charles H. Percy
Chairman

CHP:gld

Enclosure

DCI
EXEC
REG

The Verification of a Comprehensive Nuclear Test Ban

Networks of seismic instruments could monitor a total test ban with high reliability. Even small clandestine explosions could be identified even if extreme measures were taken to evade detection

by Lynn R. Sykes and Jack F. Evernden

Two treaties put into effect over the past 20 years have set limits on the testing of nuclear weapons. The Limited Test Ban Treaty of 1963, which has been signed by more than 120 nations, prohibits nuclear explosions in the atmosphere, the oceans and space, allowing them only underground. The Threshold Test Ban Treaty of 1976, a bilateral agreement between the U.S. and the U.S.S.R., prohibits underground tests of nuclear weapons with a yield greater than 150 kilotons. In the present climate of widespread pressure for more effective control of nuclear arms the idea of a comprehensive ban on all nuclear testing is receiving renewed attention. Such an agreement would be an important measure. It might inhibit the development of new weapons by the major nuclear powers, and it might also help to prevent the spread of nuclear-weapons technology to other countries.

A halt to all testing was the original goal of the negotiations that led to the 1963 Limited Test Ban. New talks with the aim of achieving a total ban were begun in 1977 by the U.S., the U.S.S.R. and Britain, but the talks were suspended in 1980. In both cases the main impediment to a comprehensive treaty was the contention by the U.S. and Britain that compliance with the treaty could not be verified because sufficiently small underground nuclear explosions could not be reliably detected and identified. In July the Reagan Administration announced that the test-ban negotiations with the U.S.S.R. and Britain will not be resumed. Once again the primary reason given was a lack of confidence in methods of verifying compliance.

In 1963 the reliability of measures for the verification of a treaty banning explosions larger than about one kiloton may have been arguable, but it no longer is. We address this question as seismologists who have been concerned for many years with the detection of underground explosions by seismic methods and with means of distinguishing underground explosions from earthquakes. We are certain that the state of knowledge of seismology and the techniques for monitoring seismic waves are sufficient to ensure that a feasible seismic network could soon detect a clandestine underground testing program involving explosions as small as one kiloton. In short, the technical capabilities needed to police a comprehensive test ban down to explosions of very small size unquestionably exist; the issues to be resolved are political.

An underground explosion sets up elastic vibrations that propagate as seismic waves through the earth and along its surface. The waves travel great distances, and seismic monitoring instruments in common use are sensitive enough to record even those generated by very small explosions. Once the waves have been detected the main task is to distinguish the seismic signals of explosions from those of earthquakes. This can be done with a network of several widely separated seismometers.

Two types of elastic vibrations can propagate through the solid body of the earth, that is, through the crust and the mantle. The first waves to arrive at a seismometer are compressional waves, which are similar to sound waves in

air or water; the seismological name for them is *P* (for primary) waves. The slower body vibrations are shear waves, which are similar to the waves on a vibrating string; they are called *S* (for shear or secondary) waves. An underground explosion is a source of nearly pure *P* waves because it applies a uniform pressure to the walls of the cavity it creates. An earthquake, on the other hand, is generated when two blocks of the earth's crust rapidly slide past each other along the plane of a fault. Because of this shearing motion an earthquake radiates predominantly *S* waves.

A result of the spherical symmetry of the explosion source is that all the seismic waves it generates have a nearly radial symmetry around the focus of the explosion. In contrast, the highly directional character of an earthquake source gives rise to seismic waves with strongly asymmetric patterns. The asymmetry in the amplitude of the waves received at seismometers throughout the world provides the means whereby seismologists can determine the faulting mechanism of a given earthquake.

In addition to the *P* and *S* body waves there are also two types of seismic waves that propagate only over the surface of the earth. They are called Rayleigh waves and Love waves, and they result from complex reflections of part of the body-wave energy in the upper layers of the earth's crust. A simple explosion can generate Rayleigh waves but not Love waves, whereas an earthquake generates waves of both types.

Seismologists characterize the size of a seismic event by means of magnitudes. A given event can be assigned several

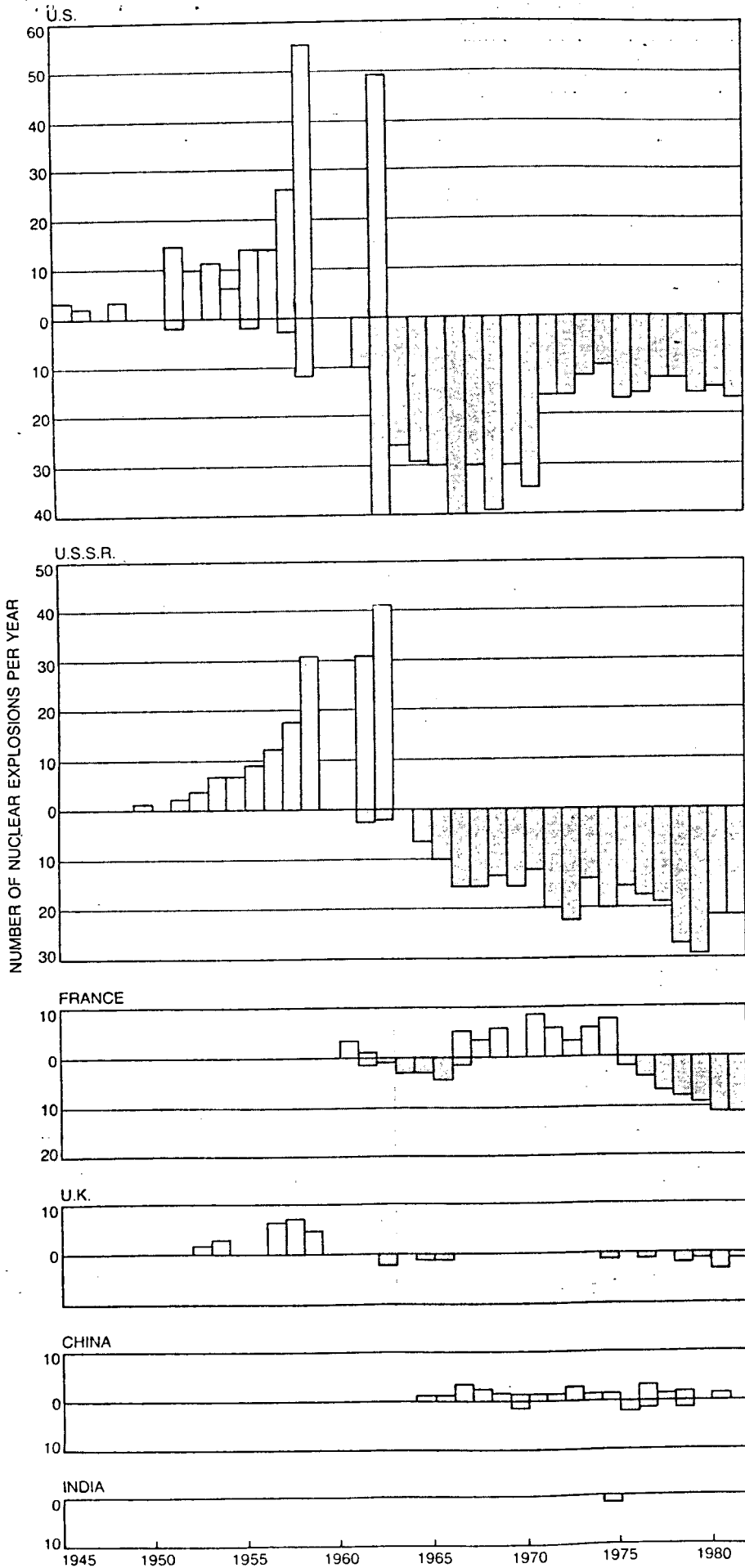

magnitudes, each one based on a different kind of seismic wave. A magnitude is the logarithm of the amplitude of a particular type of wave normalized for distance and depth of focus. Of the numerous magnitudes that can be defined for a single seismic event we shall discuss only two, which in seismological notation are designated M_S and m_b . The former is generally based on Rayleigh waves with a period of 20 seconds, the latter on one-second P waves. The magnitude of a seismic signal is ultimately related to the energy released at the site of the event. For a nuclear explosion the customary measure of energy release is the yield in kilotons, where one kiloton is the energy released by detonating 1,000 tons of TNT.

Every year there are numerous earthquakes whose magnitudes are in the range corresponding to the yields of underground explosions. Several methods can be applied to several types of waves to distinguish the seismic waves of explosions from those of earthquakes. The location of a seismic event and its depth below the surface are important criteria; indeed, the great majority of routinely detected events can be classified as earthquakes simply because they are either too deep or not at a plausible site for an explosion. The remaining events can be reliably classified by the amount of energy radiated in the several kinds of waves at various frequencies.

The location of an event in latitude and longitude is a powerful tool for classification. The position is determined by recording the arrival time of short-period P waves at several seismographic stations in various parts of the world. The travel time of the P waves to each station is a function of distance and depth of focus. From the arrival times it is possible to determine the location of the source with an absolute error of less than 10 to 25 kilometers if the seismic data are of high quality.

The identification of seismic events at sea is quite simple. It is assumed that the network monitoring a test-ban treaty would include a small number of simple hydroacoustic stations around the shores of the oceans and on a few critical islands to measure pressure waves in seawater. The hydroacoustic signal of an underwater explosion is so different

NUCLEAR TESTS CONTINUE to be carried out at a rate of about 50 per year, principally by the two leading nuclear-weapons powers: the U.S. and the U.S.S.R. As this bar chart shows, the main effect of the Limited Test Ban Treaty of 1963 (broken vertical line) was not to reduce the number of test explosions but merely to drive most of them underground. Nuclear test explosions in the atmosphere and underwater are represented by colored bars, those underground by gray bars.

from that of an earthquake and can be detected at such long range that the identification of a seismic event at sea as an explosion or an earthquake is simple and positive. Hence any event whose calculated position is at least 25 kilometers at sea (a margin allowing for errors) can be classified as an earthquake on the basis of its location and the character of its hydroacoustic signal.

The accuracy with which the position of a seismic event can be determined in an area offshore of an island arc has been tested with an array of ocean-bottom seismometers off the Kamchatka Peninsula and the Kurile Islands in the U.S.S.R. The tests indicate that the accuracy of a seismic network under these circumstances is much better than 25 kilometers. Holding to that standard, however, one finds that well over half of the world's seismic events are definitely at sea and are therefore easily identified as earthquakes.

Another large group of detected events have their epicenters on land but in regions where no nuclear explosions are to be expected; these events too can be safely classified as earthquakes. Indeed, almost all the world's seismic activity is in regions that are of no concern for monitoring compliance with a comprehensive test ban. Thus the simple act of locating seismic events classifies most of them as earthquakes.

Calculating the depth of focus provides a means of identifying a large fraction of the remaining earthquakes. From 55 to 60 percent of the world's earthquakes are at depths of more than 30 kilometers; at least 90 percent are more than 10 kilometers deep. Any seismic event as deep as 15 kilometers is certainly an earthquake. No one has yet drilled into the earth's crust as far down as 10 kilometers, and the deepest nuclear explosions have been at a depth of about two kilometers.

Several seismological procedures can be employed to determine an event's depth of focus. In most cases the depth is calculated at the same time as the location. When a seismic event is detected at 20 stations or more, a routinely calculated depth of 30 kilometers or more ensures with a 95 percent degree of confidence that the event was at least 15 kilometers below the surface.

A powerful technique for estimating depth can be applied if at least one seismological station is within a few hundred kilometers of the detected event. (A monitoring network for a comprehensive test ban would be quite likely to meet this condition in areas where nuclear testing might be expected.) A pair of *P* and *S* waves generated at the same instant and recorded by a station near the event follow identical paths but propagate at different speeds. The difference in their times of arrival, or in

P WAVE

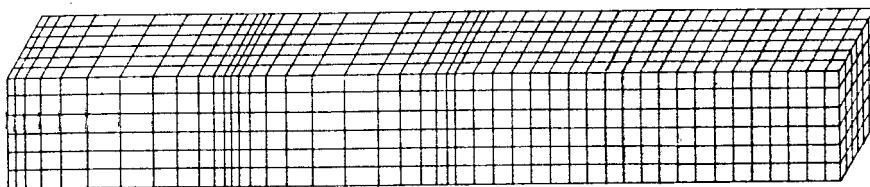

S WAVE

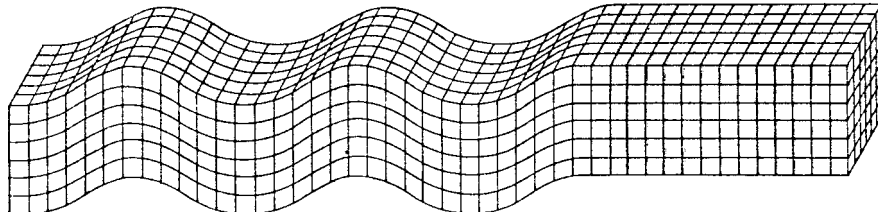

LOVE WAVE

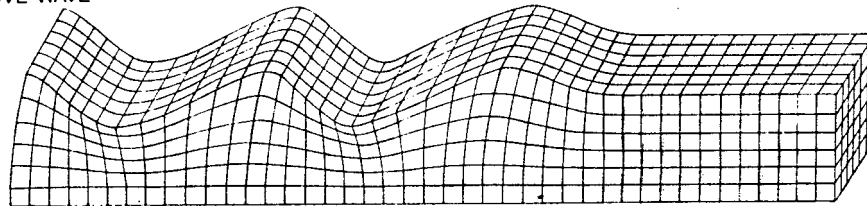

RAYLEIGH WAVE

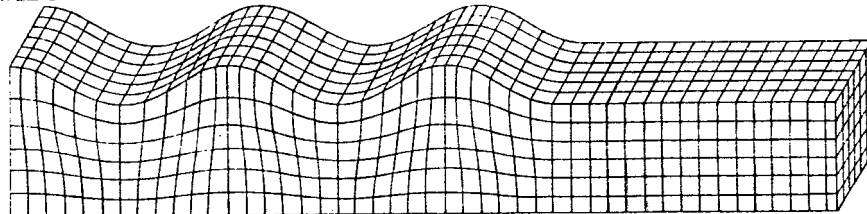

FOUR TYPES OF SEISMIC WAVE are illustrated. The two waves at the top propagate through the solid body of the earth; the two at the bottom propagate only near the surface. The compressional body waves called *P* (for primary) waves travel fastest and are the first ones to arrive at a seismometer; they are the predominant type of body wave produced by an underground explosion. The slower body waves called *S* (for shear or secondary) waves vibrate in a plane transverse to their direction of propagation; they are the predominant type of body wave produced by an earthquake. The surface waves called Rayleigh waves and Love waves result from complex reflections of the *P* and *S* body waves in the upper layers of the earth's crust.

other words the difference in their phases, therefore serves to determine the time of origin of the event. With experience the seismograms of a station near the event can be successfully analyzed to detect at least one pair of such *P* and *S* phases. Given the time of origin determined in this way and the arrival times of the *P* waves at only a few distant receivers, an accurate estimate of the depth of focus can be made.

There may remain critical seismic regions where nearby stations do not exist. Data from large events can then be employed to refine the calculated depth and location of smaller events. The essence of the technique is to correct the observed times of small events by noting the differences between the observed and the calculated times for a large event in the same area. The procedure is in routine use by several networks.

The combined effectiveness of location and depth in distinguishing earth-

quakes from explosions is impressive. More than 90 percent of all earthquakes either are under oceans or are at least 30 kilometers deep (or both). Most of the remaining earthquakes are of little interest because they are in countries that are unlikely to be testing nuclear weapons or in countries where clandestine testing would be impossible. For the U.S., of course, the U.S.S.R. is the country of prime interest. About 75 percent of the earthquakes in and near the U.S.S.R. are in the eastern part of the country near the Kamchatka Peninsula and the Kurile Islands. Almost all of the shocks in these areas either have a focal depth greater than 50 kilometers or are well offshore. It turns out that seismic events whose calculated position is on land in the U.S.S.R. or less than 25 kilometers at sea and whose calculated depth is less than 50 kilometers constitute only about .5 percent of the world's earthquakes. This amounts to about 100 earthquakes

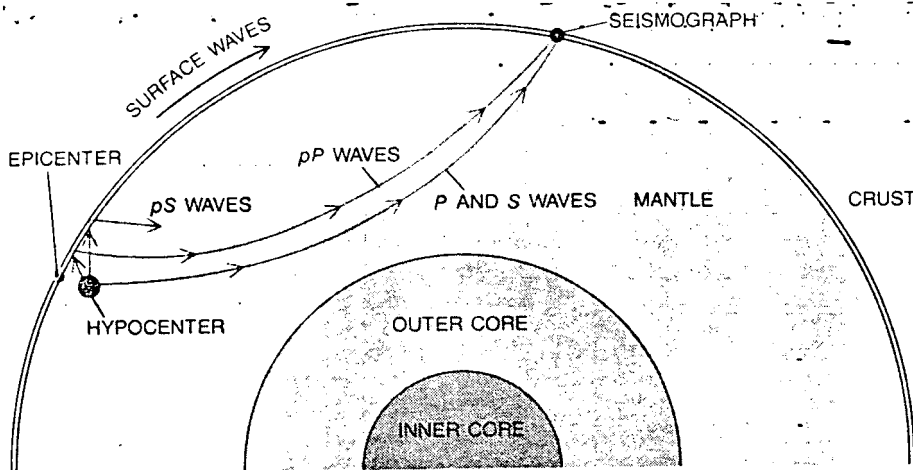

PATHS OF SEISMIC WAVES are traced on a cross section of the earth. Body waves from an earthquake or an explosion travel through the crust and mantle along the curved paths labeled *P*, *S*, *pP* and *pS*. A *pP* wave is a compressional wave that is produced by the reflection of a *P* wave from the surface of the earth just above an earthquake or an explosion; a *pS* wave is a shear wave that results from the conversion of part of the compressional energy of an upward *P* wave into transverse energy as the *P* wave is reflected from the surface. Surface waves such as Rayleigh waves and Love waves diminish rapidly in amplitude with increasing depth. The hypocenter is the focal point of an earthquake or an underground explosion from which the waves radiate. The epicenter is the point on the earth's surface directly over the hypocenter.

per year with an m_b magnitude greater than 3.8 for which other seismic discriminants must be employed.

None of the measures we have discussed so far relies on the detailed characteristics of the waves radiated by earthquakes and explosions. Several powerful discriminants are based on those characteristics, in particular on the relative amounts of energy in waves of different types and periods. For example, a shallow earthquake generates 20-second Rayleigh waves with amplitudes at least several times greater than those of an explosion that releases the same amount of energy. In the notational practice of seismology the comparison of the two magnitudes is referred to as the $M_S:m_b$ ratio, that is, the ratio of long-period to short-period waves.

A second spectral discriminant is based on the observation that long-period *P* and *S* waves are rarely or never seen in association with explosions but one type or the other is routinely detected today by simple seismometers for most earthquakes that have a one-second *P*-wave magnitude of at least 4.5. More sophisticated seismic stations and more sophisticated analysis of the signals could lower the magnitude at which such waves can be detected.

A third distinction is that surface waves of the Love type are generated far more strongly by shallow earthquakes than they are by underground explosions, including even abnormal explosions. Still another characteristic feature of the seismic signal from explosions is that the first motion of the earth stimulated by *P* waves is always upward because the explosion itself is directed

outward; the first *P*-wave motion in an earthquake can be either upward or downward.

An important factor contributing to the separation of earthquakes from explosions on an $M_S:m_b$ diagram is that *P* waves from the two kinds of events have different radiation patterns. Explosions radiate short-period *P* waves equally in all directions, whereas earthquakes have very asymmetric patterns. Hence most earthquake sources show a decrease of from .4 to one magnitude unit from the peak values when the *P*-wave amplitudes are averaged over pertinent radiation angles. A simple explosion does not initially radiate any shear waves; earthquakes typically generate large shear waves. As a result Rayleigh waves generated by many types of earthquakes have a larger amplitude than the corresponding waves generated by underground explosions of the same m_b .

There is a characteristic time for the formation of the source of a seismic event; the time is equal to the maximum source dimension divided by the velocity of source formation. The source dimension for earthquakes is the length of the break where most of the short-period energy is released; it is from three to 20 times greater, depending on the state of stress in the rocks, than the radius of the cavity and shatter zone of a comparable explosion. The velocity of source formation for earthquakes is from somewhat less to much less than the velocity of shear waves in the rocks surrounding the fault, whereas the relevant velocity for explosions is the velocity of shock waves in the rock, which is essentially the velocity of compressional waves. As a result

of these differences in the size of the source and the velocity of source formation the characteristic times for earthquakes and explosions differ by a factor of from six to 40. It is therefore not surprising that differences are observed between the short-period *P*-wave spectra of earthquakes and explosions.

Observations of several U.S. explosions have demonstrated the existence of a phenomenon called overshoot. It is related to shock waves in strong rock, but it can be thought of as the equivalent of cavity pressure rising to high values followed by a decrease in pressure by a factor of four or five; the lower pressure is then maintained for many tens of seconds. Overshoot, when it occurs, provides additional *P*-wave spectral discrimination and augments discrimination by means of the $M_S:m_b$ ratio for larger events.

It was once thought that an explosion could not give rise to any Love waves at all. A phenomenon that was of great significance in thwarting President Kennedy's effort to achieve a comprehensive test-ban treaty in 1963 was the observation that many underground nuclear explosions at the U.S. testing site in Nevada, particularly those in hard rock, generated unmistakable Love waves. The failure of the qualitative criterion "No Love waves from explosions" (at a time when such quantitative criteria as the comparison of the magnitudes of long-period and short-period waves were not adequately established) left seismologists unable to guarantee their ability to distinguish the seismic waves of underground explosions from those of earthquakes.

The presence of Love waves in the Nevada tests has since been explained. What was not considered in the earlier analyses was the influence of the natural stressed state of the earth on the waves generated by an explosion. The creation of a cavity and its surrounding shatter cone by an underground explosion leads to the release of some of the natural stress, which in turn generates seismic waves equivalent to those of a small earthquake, including Love waves. The observed waves are a superposition of the waves from the explosion and from the release of the stress.

The release of natural stress also alters the amplitude of Rayleigh waves. The perturbation has never been large enough, however, to put in doubt the nature of an event identified by the ratio of long-period to short-period waves. Only rarely does the perturbation significantly affect the amplitude of *P* waves; it is not known ever to have changed the direction of their first motion. Moreover, if the magnitude M_S is determined from Love waves rather than Rayleigh waves, the ratio method ($M_S:m_b$) provides an excellent discriminant.

In short, if seismologists had done their homework thoroughly by 1963, the nations of the world might well have achieved a comprehensive test-ban treaty then. Today the release of natural stresses in the earth is significant only as a perturbing factor that must be taken into account when the yield of an explosion is estimated from Rayleigh waves.

Reports that earthquakes occasionally have $M_S : m_b$ values like those of explosions have been cited as a factor that might impede the effective monitoring of a comprehensive test ban. In analyzing a large set of earthquakes in all parts of the world and of underground explosions in the U.S. and the U.S.S.R. we found only one example of this kind of ambiguity. The focus of the event was far from the area in which the seismometer network gave its best results.

In 1972, at a meeting of the UN Committee on Disarmament, the U.S. submitted a list of 25 "anomalous" events that were said to be indicative of a problem in discrimination. In 1976 the 25 events were reanalyzed by one of us (Sykes) and two other seismologists, Robert Tatham and Donald Forsythe. It was established that about half of the events had $M_S : m_b$ values that put them clearly in the earthquake population. Most of the original magnitudes had been determined from only one or two stations, and much existing information had not even been consulted. When

the records of other available stations were examined, the events ceased to be "anomalous."

For the remaining problem events $M_S : m_b$ measurements based on 20-second Rayleigh waves gave values in the range characteristic of explosions. Several of these events were at depths of from 25 to 50 kilometers, where the possibility of nuclear testing can be excluded in any case, but the magnitude ratio nonetheless demanded explanation. It is known from seismological theory that certain types of earthquakes at these depths excite long-period Rayleigh waves poorly. The theory predicts, however, that Love waves and vibrations called higher-mode Rayleigh waves are in many instances vigorously generated in these circumstances. An analysis of recordings of the Love waves and the higher-mode Rayleigh waves identified several more of the problem events as earthquakes.

Only a single sequence of events at one place in Tibet remained as a problem. In that region underground nuclear testing is unlikely, but the nature of the events could not be determined with certainty from the magnitude ratios. We think the reason is that with the seismographic networks of the 1960's, when the events were recorded, Love waves could not be detected for small-magnitude events because they were obscured by background earth noise. New instal-

lations and new modes of data processing have greatly reduced the problem. If the same series of events or a similar series were to take place today, we think they would be identified unambiguously. Long-period seismographs in boreholes and routine digital processing of seismograms lead to a suppression of background noise and increase the detectability of many types of waves, including Love waves.

As it happened, the nature of the Tibetan problem sequence was resolved in spite of the inadequacies of the long-period data of the time. At several stations the first motion of the P waves was downward, which is not possible for an explosion. Hence the events must have been small earthquakes.

It seems reasonable to say that for the networks we shall describe below there should no longer be any problem events at m_b 4 or more. We know of no Eurasian earthquake with a one-second P -wave magnitude of 4 or more in the past 20 years whose waves are classified as those of an explosion. (Of course, numerous smaller Eurasian earthquakes during that period went unidentified because of inadequate data.) Furthermore, to our knowledge not one out of several hundred underground nuclear explosions set off in the same period radiated seismic waves that could be mistaken for those of an earthquake. Our experience indicates an extremely low proba-

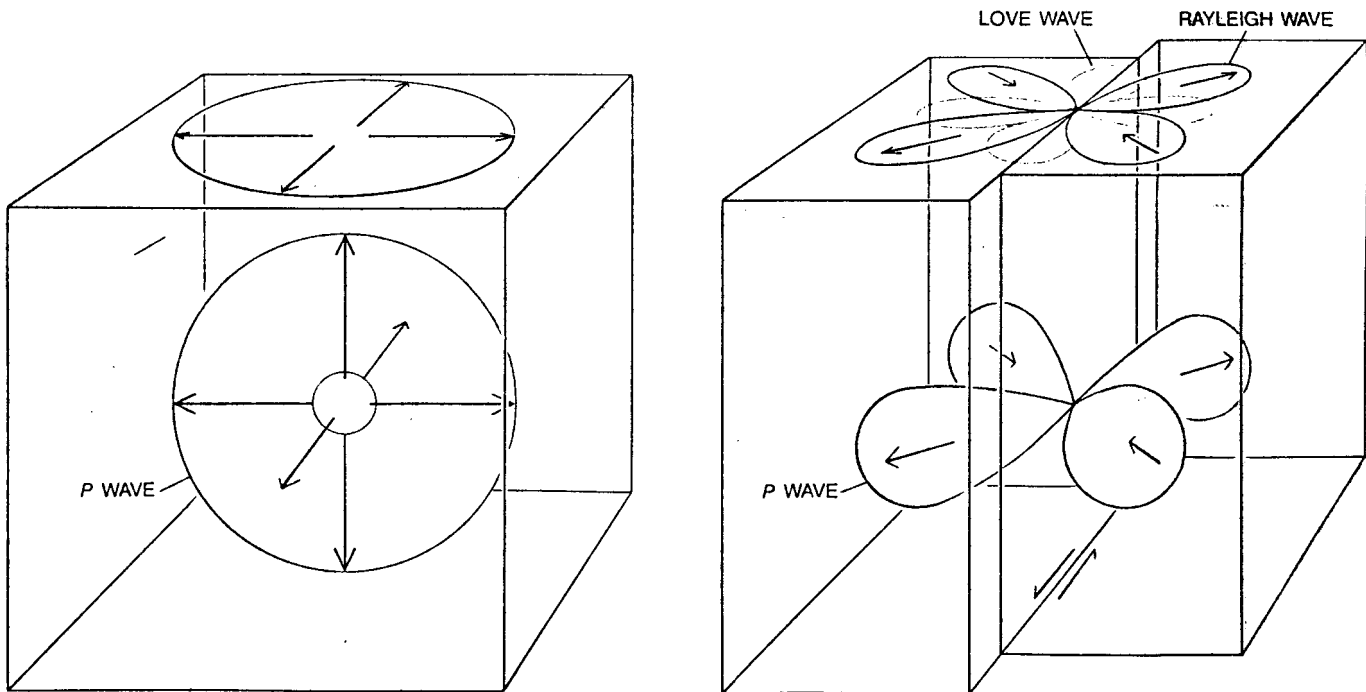

RADIATION PATTERNS of the P waves resulting from an underground explosion (left) and an earthquake (right) are compared. The first motion of the P waves from an explosion is uniformly outward and hence is generally observed as an upward displacement at all seismic stations. The first motion of the P waves from an earthquake is outward in some directions and inward in others; the pattern of the waves at the surface depends on the orientation of the plane of the

earthquake fault. In the comparatively simple case of a vertical strike-slip fault, shown here, the four-lobed radiation pattern observed at the surface for both P waves and Rayleigh waves is a simple projection of the three-dimensional P -wave configuration emanating from the hypocenter of the earthquake. The radiation pattern of the Love waves emitted by the same source is rotated by 45 degrees with respect to the surface pattern of the P waves and the Rayleigh waves.

bility that an event will remain unidentified when all the available techniques of discrimination are brought to bear.

No monitoring technology can offer an absolute assurance that even the smallest illicit explosion would be detected. We presume that an ability to detect and identify events whose seismic magnitude is equivalent to an explosive yield of about one kiloton would be adequate. It is often assumed that for the U.S. to subscribe to a comprehensive test ban it would require 90 percent confidence of detecting any violation by another party to the treaty. Developing a new nuclear weapon, however, generally requires a series of tests, and the probability that at least one explosion will be detected rises sharply as the number of the tests is increased. Moreover, a 90 percent level of confidence for the detection of even a single explosion probably is not needed. For a country seeking to evade the treaty the expected probability of detection would certainly have to be less than 30 percent, and perhaps much less, even if only one illicit test were planned. The test-ban agreements that have been considered over the years all include an "escape clause" through which a country could renounce its treaty obligations. Unless the probability of detection were very low, a country whose national interest seemed to demand a resumption of testing would presumably invoke the escape clause rather than risk being caught cheating.

Given these standards of reliability for a monitoring system, it is possible to specify the size and the sensitivity of the

seismic network that would be needed to verify compliance with a comprehensive test ban. Two kinds of network can be considered for maintaining seismic surveillance of the U.S.S.R. One network consists of 15 stations outside the borders of the U.S.S.R. In the second network the 15 external stations are supplemented by 15 internal ones.

The ultimate limit on the detection of seismic signals is imposed by microseisms, or random vibrations of the earth's surface. Most microseisms are induced by the earth's atmosphere and oceans. In order to detect a one-kiloton explosion in much of the U.S.S.R. a monitoring network would have to be able to recognize above the background noise any event with a short-period *P*-wave magnitude of 3.8 or more. In order to distinguish an explosion from an earthquake by comparing the long-period magnitude with the short-period one, the network would also have to be able to detect surface waves with an M_S magnitude of 2.5 or more. The network of 15 external stations could achieve these goals. Indeed, since almost all the seismic areas of the U.S.S.R. are along its borders, the external network would be sensitive to events of even smaller magnitude there. The mere detection of a seismic event in most areas of the interior would constitute identification of the event as an explosion.

The lower limit of one kiloton on the yield of an explosion that could be detected by an external network is based on the assumption that the coupling between the explosion and the seismic radiation is efficient and that the explosion

was not set off during or soon after a large earthquake. If one must consider the possibility that a country would try to evade a test-ban treaty by decoupling, or muffling, an explosion and thereby reducing the amplitude of the emitted seismic signals, an improved network would be required. In principle such muffling could be done by detonating the explosion in a large cavity or by using energy-absorbing material in a smaller cavity. The former stratagem might reduce the seismic signal of an explosion by 1.9 magnitude units as measured by one-second *P* waves (that is, by m_b). The latter stratagem might bring a reduction of one unit.

The use of an oversize cavity is clearly the more worrisome possibility, but it could be attempted only in certain geologic formations: a salt dome or a thick sequence of bedded salt deposits. Few areas of the U.S.S.R. have deposits of salt in which the construction of a cavity large enough for decoupling a several-kiloton explosion would be possible. The maximum size of a cavity that could reasonably be constructed and maintained sets a limit of two kilotons on explosions that might be muffled in this way and escape detection by the 15-station external network.

Another way to reduce the amplitude of radiated seismic waves is by detonating an explosion in a low-coupling medium such as dry alluvium. The maximum thickness of dry alluvium in the U.S.S.R. sets a limit of 10 kilotons on explosions that might be concealed by this means, again assuming that only the 15 external stations were installed.

ARCTIC EARTHQUAKE
SEPTEMBER 8, 1972 $m_b=5.9$

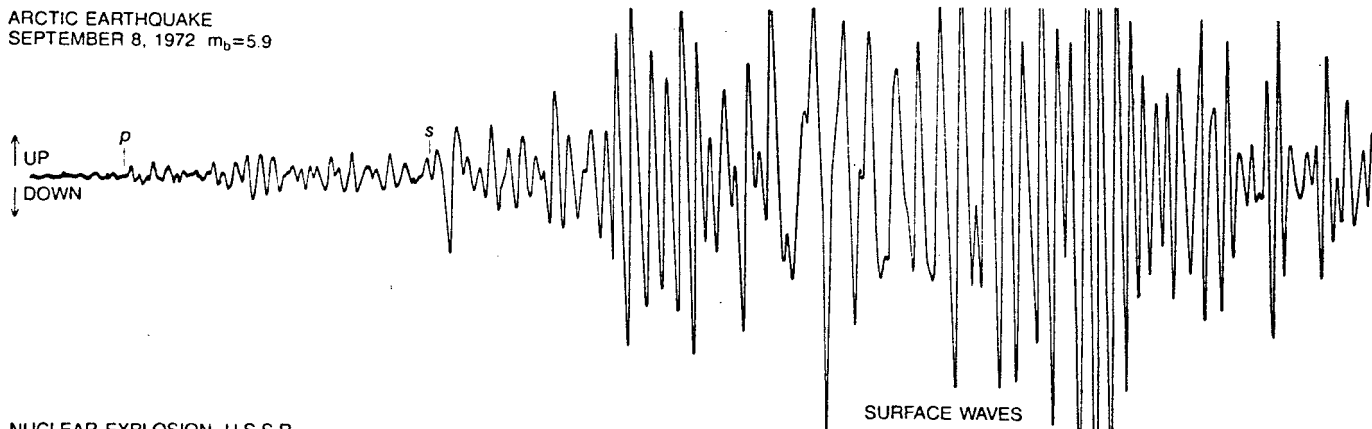

NUCLEAR EXPLOSION, U.S.S.R.
AUGUST 28, 1972 $m_b=6.3$

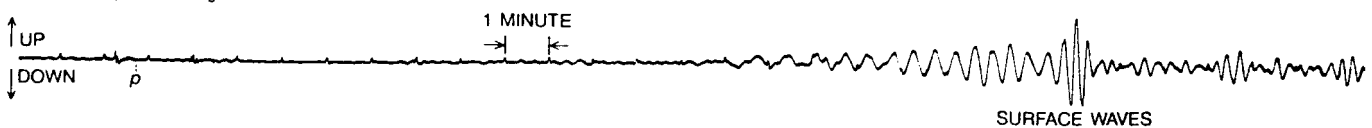

SEISMOGRAMS OF LONG-PERIOD WAVES from an earthquake in the Arctic near the U.S.S.R. (top) and an underground nuclear explosion in the U.S.S.R. (bottom) were recorded at a seismic station in Elath, Israel, roughly equidistant from the two events. The short-period body waves generated by the two shocks were observed to have almost the same magnitude. The magnitude of the long-period Rayleigh waves recorded in these traces, in contrast, is clearly

much greater for the earthquake than it is for the explosion. The ratio of long-period surface waves to short-period body waves has been shown to be a reliable criterion for distinguishing the seismic waves of earthquakes from those of explosions. In addition the *P* wave of the explosion has more high-frequency energy than the *P* wave of the earthquake. The *S* wave of the earthquake is large, whereas that of the explosion is small and not easily identified in the seismogram.

Another possible drawback of an exclusively external network should be mentioned. Confusion could arise when signals from two or more earthquakes reached a station simultaneously. The effect would be most troublesome when the long-period waves from a small event in the U.S.S.R. arrived at the same time as similar waves from a much larger earthquake elsewhere in the world. Under these circumstances it might be difficult to establish with certainty by comparing M_S with m_b the identity of the event in the U.S.S.R. With a network of 15 external stations there would be a few events per year in which the smaller earthquake was in the territory of the U.S.S.R. or within 25 kilometers of its borders and at a depth of less than 50 kilometers.

A monitoring network made up of 15 seismographic stations outside the U.S.S.R. and 15 inside it would largely eliminate the problem of coincident earthquake signals and would greatly reduce the maximum yield of an explosion that might escape detection, even if decoupling were attempted. The internal monitoring stations would be simple unattended ones, with the capability of measuring vertical ground motion and two orthogonal components of horizontal motion, so that the distance and direction of a nearby event could be estimated from the data of a single short-range station. With such a network in place, and assuming that muffling was attempted in the presence of normal earth noise, the largest explosion that would have a 30 percent chance of escaping detection in any setting except a salt dome would be .5 kiloton.

For salt domes the main area of concern in the U.S.S.R. is the region north of the Caspian Sea. Our hypothetical network has three stations there. Even a small explosion in a large salt-dome cavity would emit certain P and S waves with an amplitude large enough to be detected by nearby stations. Furthermore, detection by even one of the stations would immediately identify the event as an explosion because the area has no natural seismic activity. As a result evasion would not be likely to be attempted at a yield greater than one kiloton even in the salt-dome area.

A possible strategy for evasion that has been mentioned from time to time is the one of hiding the seismic signal of a nuclear explosion in the signal of a large earthquake, which might be near the site of the explosion or far from it. For the U.S.S.R. the only credible possibility is a distant earthquake because the only possible testing sites where earthquakes are frequent enough to make the effort worth while are on the Kamchatka Peninsula and in the Kurile Islands. Clandestine testing there is not likely because seismic activity in the area can be moni-

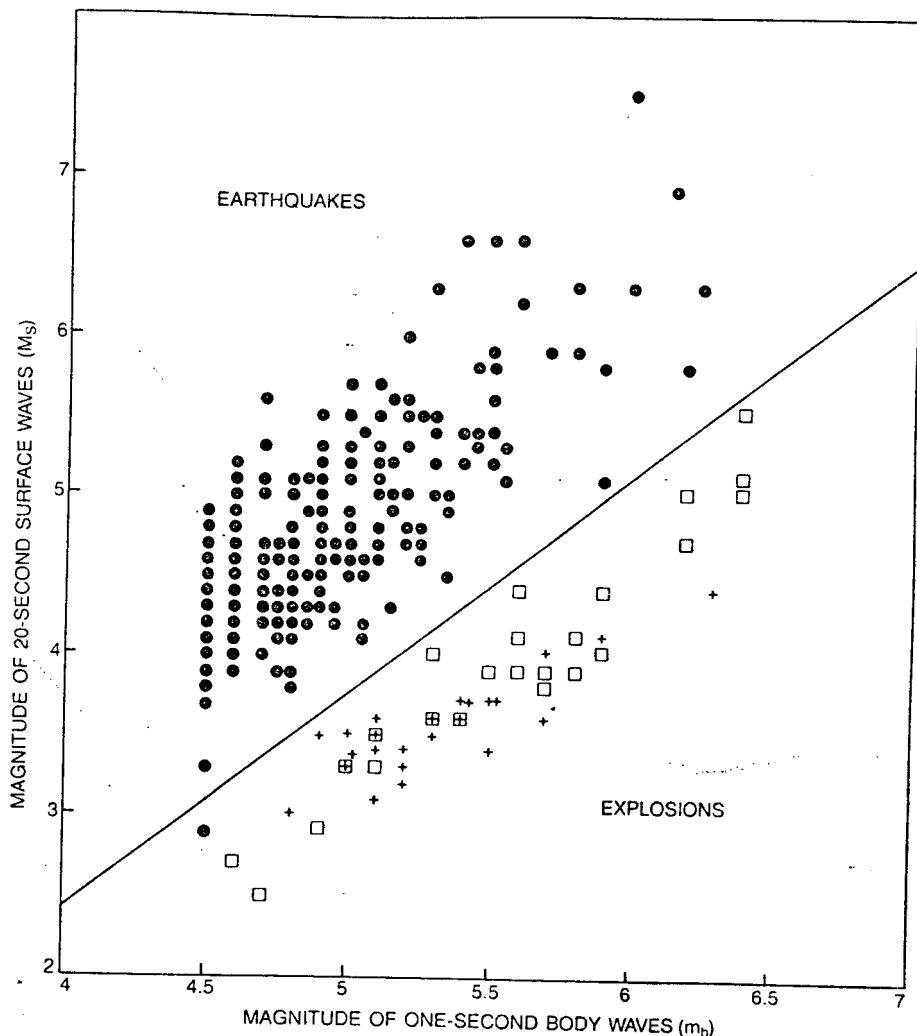

CLEAR DISTINCTION between earthquakes and explosions is evident in this plot of the magnitude of long-period surface waves (M_S) against that of short-period body waves (m_b). The 383 earthquakes represented by the black dots were compiled from a set of all the earthquakes recorded worldwide in a six-month period that had an m_b value of 4.5 or more and a focal depth of less than 30 kilometers. (There are fewer dots than earthquakes because the magnitudes of some of them coincided.) The colored squares designate underground explosions in the U.S. and the colored crosses underground explosions in the U.S.S.R. Only one earthquake falls within the explosion population, as defined by the straight line separating the two groups of events. This single event, which had the smallest magnitude of any of the earthquakes in the survey, took place in the southwest Pacific Ocean, a region where the sensitivity of the network of seismic stations is poorer than it is in most of the Northern Hemisphere. The m_b values were adjusted to take into account regional variations in the amplitudes of short-period waves.

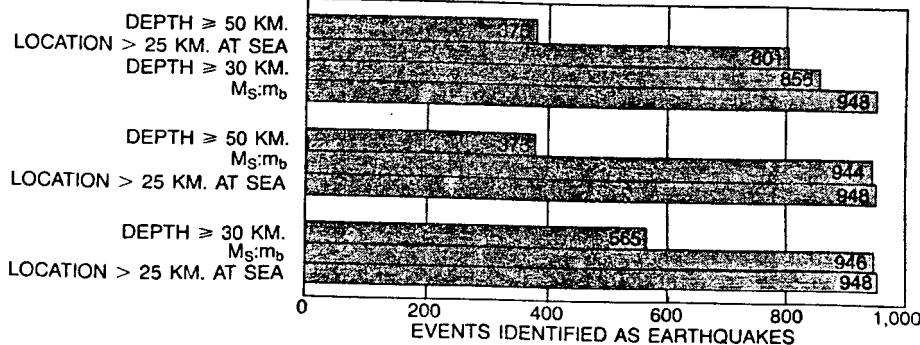

METHODS OF DISTINGUISHING earthquakes from explosions were tested by applying the methods to all the earthquakes with a magnitude of 4.5 or more recorded during a 162-day period in 1972. The sample consisted of 948 events. Many of them could be classified as earthquakes (rather than explosions) by their location or their depth. The remaining events could be classified by comparing the magnitude of long-period surface waves with the magnitude of short-period body waves (the ratio $M_S:m_b$). The sequence in which the tests were applied affected the efficiency of the procedure, but all events were identified regardless of the sequence.

ored in detail from stations in Japan and the Aleutian Islands. Indeed, ocean-bottom seismometers and hydroacoustic sensors could be placed just offshore.

The first defense against evasion by the masking of a test in a large earthquake is the questionable feasibility of the subterfuge. Unless the evader maintained several testing sites the number of opportunities per year for clandestine testing would be quite limited. In addition the evader would have to maintain his weapons in constant readiness for firing. To attain the evasion capability given below he would have to set off an explosion within 100 seconds of the time of arrival of the short-period waves of the earthquake. He would have to estimate the maximum amplitude and the decay rate of the earthquake waves with high accuracy, and he would have to be certain of the amplitude of the P waves generated by the explosion to within .1 magnitude unit. Even after taking these precautions the evader would have to accept a high probability that the event would be detected by at least one monitoring station and a small probability that three stations would detect it. He would also have to install and operate his testing site (including a large cavity) and his own seismological network in total secrecy over a period of years.

In contrast to these daunting requirements for successful evasion, the only requirements for a monitoring nation are to operate a network of high-quality seismic stations and to process the data with determination. Against a network of 15 external stations and 15 internal

ones the only effective evasion schemes at yields of one kiloton or more would require both decoupling and hiding the explosion signal in an earthquake.

The issues relating to the monitoring of a comprehensive test ban can be summarized as follows. The understanding of seismology and the testing of seismometer networks are sufficiently complete to ensure that compliance with a treaty could be verified with a high level of confidence. The only explosions with a significant likelihood of escaping detection would be those of very small yield: less than one kiloton provided the monitoring system includes stations in the U.S.S.R.

It is important to view the question of yield in the context of the nuclear weapons that have been tested up to now. The ones that ushered in the nuclear age in 1945 had a yield of from 15 to 20 kilotons. Yields increased rapidly to the point where the U.S.S.R. tested a 58,000-kiloton weapon in 1961. The largest underground explosion had a yield of almost 5,000 kilotons. Unclassified reports place the yield of the weapons carried by intercontinental missiles in the range from 40 to 9,000 kilotons. The yields of underground explosions that might go undetected or unidentified under a comprehensive test ban are therefore much smaller than those of the first nuclear weapons. If the threshold of reliable detection and identification is one kiloton, that is only one-150th of the limit specified by the Threshold Test Ban Treaty of 1976.

From the viewpoint of verification a comprehensive test ban would actually establish the equivalent of a very low threshold, since weapons of extremely low yield could be tested underground without the certainty of being detected and identified. A treaty that imposed a threshold near the limit of seismological monitoring capability might therefore be considered an alternative to a comprehensive test ban. Such a treaty might be preferable to the present quite high threshold, but it would have the disadvantage that arguments could arise over the exact yield of tests made near the threshold. Indeed, the judgment of whether or not a test has taken place will always be less equivocal than an exact determination of yield.

In recent years there have been reports that the U.S.S.R. may have repeatedly violated the 1976 treaty by testing devices with a yield greater than the 150-kiloton limit. Such reputed violations were recently cited as evidence that the threshold treaty, which has not been ratified by the U.S. Senate, is not verifiable and should be renegotiated. On the basis of our analysis we conclude that the reports are erroneous; they are based on a miscalibration of one of the curves that relates measured seismic magnitude to explosive yield. When the correct calibration is employed, it is apparent that none of the Russian weapons tests exceed 150 kilotons, although several come close to it.

Observations at the Nevada Test Site (NTS), where American nuclear-weapons tests are held, indicate there are lin-

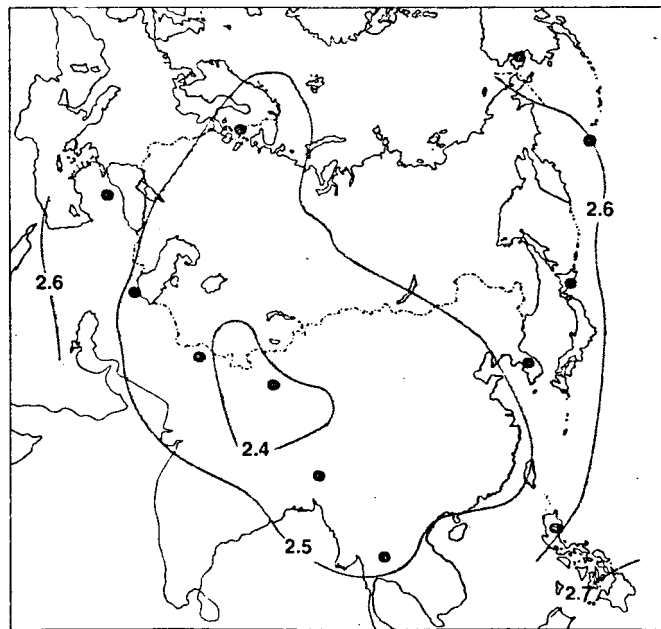
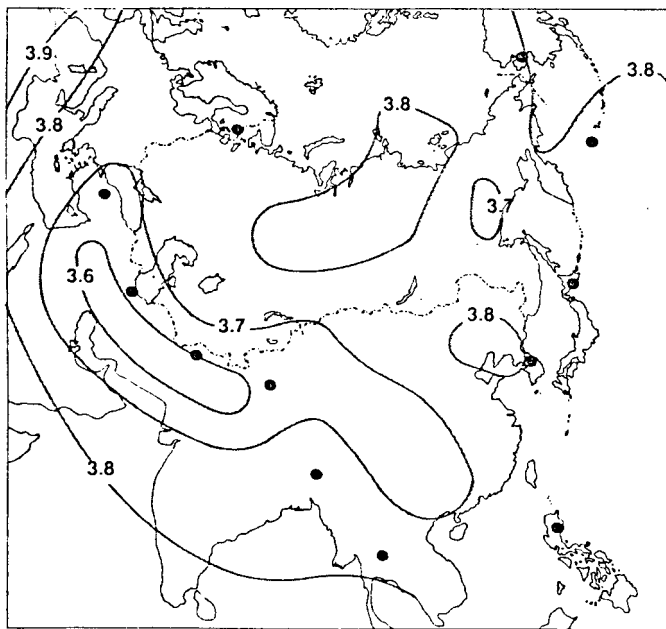

THRESHOLDS OF DETECTION for seismic events in the Eastern Hemisphere are delineated by the two sets of contours drawn on this pair of maps for a proposed network of 15 seismic stations established outside the U.S.S.R. Colored dots give the location of 12 of the 15 stations; three others are off the maps. The number on each contour indicates that an event of that magnitude or larger has at least a 90

percent probability of being detected by four or more stations. The contours on the map at the left represent the detection thresholds for short-period body waves and those on the map at the right the detection thresholds for long-period surface waves. On these maps and the ones on the opposite page the only seismic noise taken into account is the microseismic noise generated by the atmosphere and oceans.

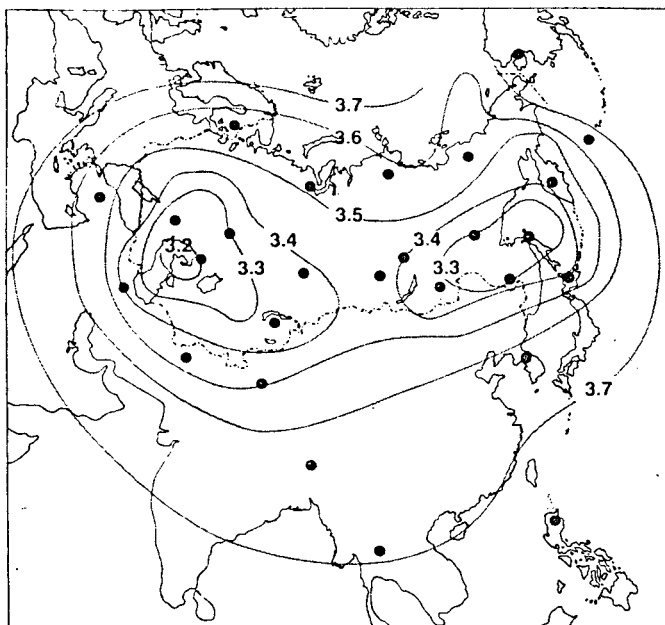

IMPROVED DETECTION THRESHOLDS for seismic events in the Eastern Hemisphere are delineated by the two sets of contours drawn on this pair of maps for a proposed network of 30 seismic stations: 15 outside the U.S.S.R. and 15 inside. For most of the U.S.S.R. the effect of adding the 15 interior stations would be to lower the de-

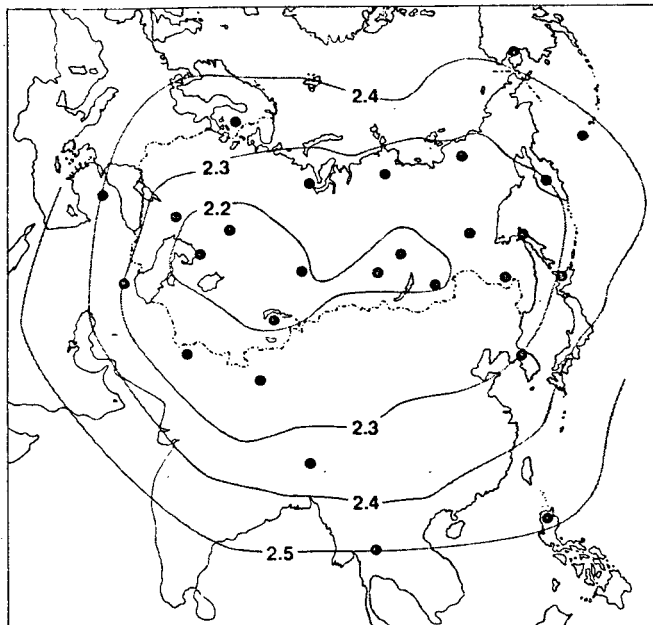

tection threshold for short-period body waves from a magnitude of 3.8 to one of 3.4 (left); the corresponding effect for long-period surface waves would be to lower the detection threshold from a magnitude of 2.6 to one of 2.3 (right). The interior stations would also provide more accurate information on the focal depth of a seismic event.

ear correlations between the logarithm of the explosive yield and the two magnitude values, M_S and m_b , for explosions with yields greater than 100 kilotons. When the measured M_S and m_b values of explosions at the Russian test site near Semipalatinsk are inserted into the NTS formulas, however, the resulting estimates of yield given by m_b are more than four times as great as those given by M_S . For explosions in hard rock at many test sites estimates of yield based on the NTS M_S formula have invariably agreed with actual yields, whereas estimates based on the NTS m_b formula have sometimes been in drastic disagreement with the actual yield.

A strong correlation has been found between m_b values measured at individual stations and P -wave travel times to these stations. The U.S.S.R. routinely publishes seismological bulletins that include P -wave arrival times of earthquakes, and it is straightforward to interpret the times-for stations in central Asia in terms of the expected pattern of m_b values near Semipalatinsk. From an analysis of the P -wave signals it is predicted that the m_b value for an explosion at Semipalatinsk is 40 percent greater than an equivalent explosion at NTS. This is the same correction that must be applied to the curve relating m_b to yield at NTS to make the m_b estimates of the yield of Russian explosions consistent with the M_S estimates. Thus two modes of analysis lead to the conclusion that there is an essentially universal relation between M_S and yield whereas the curve relating m_b to yield must be calibrated for each test site.

A comprehensive treaty would have an additional advantage over a low-threshold treaty: all technological uncertainties would work against the potential evader. A country planning a surreptitious nuclear test could not know the exact seismic-detection capability of other nations or the exact magnitude of the seismic waves that would be generated by his test. A ban on nuclear explosions of all sizes would also have the important conceptual value that nuclear weapons, no matter what their size, would be recognized as inherently different from conventional weapons.

It is sobering to consider how the state of the world would differ if a full test ban had been achieved in 1963. The number of nuclear weapons has grown tremendously since then and is now estimated at from 50,000 to 100,000. The loss of life and the social damage that would be inflicted in a major nuclear exchange are vastly greater than they were in 1963. Furthermore, both the U.S. and the U.S.S.R. are less secure now than ever before, not because of any failure to develop arms but because of the growing stockpiles of weapons and the inability of any nation to defend itself against nuclear attack.

A comprehensive test-ban agreement should not be regarded as a substitute for disarmament. Meaningful reductions in the nuclear threat must include a continuing and serious process of arms control; in this process, however, a comprehensive test-ban treaty could have an important part. The problems of negotiating such a treaty are overwhelmingly

political rather than technical and must be recognized as such.

Before the suspension of negotiations between the U.S., Britain and the U.S.S.R. in 1980 tentative agreement had been reached on a number of issues. All three nations agreed that a test-ban treaty would include a prohibition of all tests of nuclear weapons in all environments, a moratorium on peaceful nuclear explosions until arrangements for undertaking them could be worked out, provisions for on-site inspections, a mechanism for the international exchange of seismic data and the installation of tamperproof seismic stations by each country in the territory of the others. The proposed treaty would have a term of three years. The agreements on the long-standing issues of on-site inspection, peaceful explosions and the placement of monitoring stations in each country represented important breakthroughs. It would be a setback for the cause of international security if this hard-won ground were now lost.

For many years the stated policy of the U.S. has emphasized the desirability of a complete test ban if verification could be ensured. The policy was not fundamentally altered by the recent decision of the Reagan Administration to put off further negotiations on the test ban. On the contrary, it was reported that the Administration still supports the ultimate goal of a comprehensive ban on nuclear testing but has doubts about the efficacy and reliability of seismic methods of verification. As we have attempted to show here, there can be no substance to such doubts.