

C 28168

FIELD AND LABEL LINE IDENTIFIERS

CPYRGHT

THERE ARE SEVERAL TYPES OF PAPER MACHINES IN OPERATION TODAY. EACH TYPE HAS MODIFICATIONS TO SUIT LOCAL CONDITIONS, AS WELL AS THE ACTUAL MARKET REQUIREMENTS. PAPER MACHINES ARE NOT BUILT AS STANDARD PIECES OF EQUIPMENT BUT ARE CONSTRUCTED ACCORDING TO THE GRADE OF PAPER TO BE MANUFACTURED. THROUGHOUT THE VARIED TYPES OF PAPER MACHINE DESIGNS, THE SAME ESSENTIAL PARTS ARE FOUND IN EVERY MAKE OF MACHINE.

THE FIRST PAPER MACHINES HAD NO SUCTION BOXES OR SUCTION ROLLS AND REQUIRED NO VACUUM PUMPS BECAUSE OF THE EXTREMELY SLOW SPEED. AS MACHINE SPEEDS WERE INCREASED TO OBTAIN GREATER PRODUCTION, VARIOUS METHODS OF REMOVING WATER BY VACUUM WERE USED. THE TREND TODAY IS FOR CONTINUED INCREASE IN MACHINE SPEEDS, REQUIRING MORE WATER REMOVAL EQUIPMENT AND MORE VACUUM PUMPS.

FOURDRINIER MACHINE

THE FOURDRINIER MACHINE IS DIVIDED INTO TWO MAIN SECTIONS, THE WET AND THE DRY END. THE PULP FIBRES WHICH HAVE BEEN PREPARED BY THE BEATERS, OR THE JORDANS, ARE BROUGHT TO THE WET END OF THE MACHINE AND FELTED INTO A SHEET OF PAPER OR BOARD. THIS SHEET IS CARRIED IN THROUGH THE PRESS SECTION TO THE DRYER SECTION WHERE THE REMAINING MOISTURE IS REMOVED AND THE SHEET THEN IS WOUND ON ROLLS READY FOR SHIPMENT.

TO SERVE AS A GUIDE IN THE STUDY OF THE FOURDRINIER MACHINE, THE FOLLOWING LIST OF ESSENTIAL PARTS IS GIVEN:

- | | | |
|---------------------|-------------------------|-----------------------|
| 1. HEAD BOX | 7. SUCTION BOXES | 13. FELT CONDITIONERS |
| 2. APRON | 8. DANDY ROLL | 14. WET FELTS |
| 3. SLICES | 9. SHAKE | 15. DRYERS |
| 4. FOURDRINIER WIRE | 10. SUCTION COUCH ROLLS | 16. CALENDERS |
| 5. TABLE ROLLS | 11. SUCTION PRESS ROLLS | 17. REELS |
| 6. DECKLE STRAPS | 12. PLAIN PRESS ROLLS | 18. WINDER |

Approved For Release 1999/09/10 : CIA-RDP83-00423R001000470002-7

HEAD BOX

THE PULP FIBRES ARE DELIVERED TO THE HEAD BOX, WHICH IS DESIGNED TO ALLOW THE WATER AND PULP MIXTURE TO FLOW UPON THE APRON AND THE WIRE. THE OUTLET FROM THIS BOX IS DESIGNED SO THAT THE STOCK STREAM IS SMOOTH AND FREE FROM ANY TURBULENCE WHICH WOULD CAUSE UNEVEN CONSISTENCY AS IT FLOWS ON TO THE WIRE.

APRON AND SLICES

THE APRON IS MERELY A CONDUIT OR SHALLOW TROUGH WHICH GUIDES THE STOCK FROM THE HEAD BOX TO THE WIRE. THE SLICES ARE PLACED ACROSS THE WIRE IN A VERTICAL POSITION AND ACT AS A DAM IN HOLDING BACK THE STOCK, THUS INSURING A STEADY FLOW OF WATER AND FIBRE AT THIS POINT. THERE ARE USUALLY TWO SLICES AND THESE ARE ADJUSTED TO CONFORM WITH THE WIDTH OF THE SHEET.

FOURDRINIER WIRES

THE FOURDRINIER WIRE HAS A SEVERE DUTY TO PERFORM AND THEREFORE IT MUST BE CAREFULLY MADE FROM THE BEST MATERIALS AVAILABLE. HIGH GRADE PHOSPHOR BRONZE, HIGH GRADE BRASS WIRE AND MONEL METAL ARE COMMONLY USED IN ITS MANUFACTURE. THE RANGE OF MESH OF THESE WIRES VARIES, DEPENDING UPON THE GRADE OF PAPER TO BE MADE. THE FINER MESH WOULD BE USED FOR SPECIAL PAPERS SUCH AS CONDENSER AND CIGARETTE PAPER. THIS WIRE IS JOINED TOGETHER IN THE FORM OF AN ENDLESS BELT AND CARRIES THE STOCK OVER THE SUCTION BOXES AND COUCH ROLL TO THE PRESS SECTIONS. FROM HERE THE SHEET IS CARRIED ON FELTS TO THE DRYER SECTION OF THE PAPER MACHINE. WIRES ON HIGH SPEED MACHINES, SUCH AS NEWSPRINT, WHICH RUN AS HIGH AS 1500 FEET PER MINUTE OR MORE, MAY BE RAISED AT THE BREAST ROLL. THIS FEATURE IS SOMETIMES EMPLOYED UNLESS A PRESSURE HEAD BOX IS USED, TO ENABLE THE STOCK TO MOVE AT THE SAME RATE OF SPEED AS THE FOURDRINIER WIRE. IF THE STOCK WERE MOVING MORE SLOWLY THAN THE WIRE, THE SHEET WOULD BE ROUGH AND NOT PROPERLY FELTED. IF THE STOCK WERE RUNNING FASTER THAN THE WIRE, A STREAKY SHEET MIGHT RESULT AS THE STOCK MAY ACCUMULATE IN PUDDLES.

A SHEET OF PAPER BEGINS TO FORM SOON AFTER THE STOCK HAS TRAVELED A SHORT DISTANCE ON THE WIRE. A GUIDE ROLL CONTROLLED BY AN AUTOMATIC DEVICE CALLED THE "WIRE GUIDE" IS USED TO KEEP THE WIRE IN PROPER ALIGNMENT. IT IS USUALLY LOCATED BETWEEN THE SUCTION COUCH ROLL AND THE LAST SUCTION BOX AND IS AT THE SAME ELEVATION AS THE SUCTION BOX.

TABLE ROLLS

THE FOURDRINIER WIRE TRAVELS OVER, AND IS SUPPORTED BY A SERIES OF ROLLS CALLED "TABLE ROLLS". THESE ROLLS ARE PLACED IN A PARALLEL POSITION, FORMING A TABLE, AND THEY AID IN DRAINING THE WATER FROM THE STOCK BEING CARRIED ON THE WIRE. THE COMPARATIVELY FINE MESH HAS ENOUGH CAPILLARY ATTRACTION TO HOLD MOST OF THE LIQUID ON TOP OF THE WIRE. THE TABLE ROLLS ARE ROTATED BY THE TRAVELING WIRE, OVERCOMING THIS ATTRACTION AND ALLOWING THE WATER TO DRAIN AWAY. IT WILL BE NOTED THAT THERE IS A CONTINUOUS STREAM OF WATER LEAVING THE FORWARD SIDE OF EACH ROLL.

DECKLE STRAPS

IN SOME CASES A NARROW ENDLESS BELT OR STRAP IS LOCATED ON EACH SIDE OF THE FOURDRINIER WIRE, WITH THE UNDERSIDE LYING FLAT ON THE WIRE. THESE ARE CALLED "DECKLE STRAPS" AND PREVENT THE FIBRES FROM SPREADING BY FORMING A DAM ON THE SIDE OF THE WIRE. THESE DECKLE STRAPS ARE CARRIED ON INDIVIDUAL PULLEYS WHICH CAN BE MOVED IN OR OUT, THUS FIXING THE WIDTH OF THE SHEET. THE STRAPS HOLD THE EDGES OF THE SHEET UNTIL IT BECOMES SUFFICIENTLY FELTED AND DRAINED TO A CONSISTENCY WHERE IT CAN STAND UP WITHOUT SPREADING FOR THE REMAINING TRAVEL ON THE WIRE.

SUCTION BOXES

AS CAN BE SEEN, IT IS NECESSARY TO EMPLOY SOME FURTHER METHOD OF DRAINAGE IN ORDER TO FACILITATE THE REMOVAL OF WATER FROM THE WIRE AND SHEET WITHIN A REASONABLE TIME. SUC-

TION BOXES ARE INSTALLED FOR THIS PURPOSE AND ARE USUALLY MADE OF BRONZE AND FITTED WITH COVERS OF VARIOUS MATERIALS. THEY EXTEND FOR THE FULL WIDTH OF THE MACHINE AND THE COVERS IN MOST CASES HAVE 1/2" DRILLED HOLES OR OTHER OPENINGS WHICH ALLOW THE WATER TO DRAIN FROM THE WIRE AS IT PASSES OVER THE BOX. AS MANY AS TWELVE OF THESE SUCTION BOXES MAY BE USED ON ONE PAPER MACHINE. THESE BOXES ARE TIGHTLY CONSTRUCTED AND HAVE A CONNECTION AT EITHER OR BOTH ENDS WHICH IS PIPED TO A VACUUM PUMP. PLUNGERS, OR ADJUSTABLE PLUGS, ARE INSTALLED IN THE ENDS OF EACH BOX SO THAT THE VACUUM AREA MAY BE INCREASED OR DECREASED, DEPENDING UPON THE WIDTH OF SHEET DESIRED.

THE DESIGN OF PAPER MACHINES HAS BEEN IMPROVED TO ALLOW FOR GREATER WIDTH OR GREATER SPEEDS BUT THE CROSS SECTIONAL AREA AND SIZE OF THE END OPENING ON THESE SUCTION BOXES IN SOME CASES HAS NOT BEEN CHANGED; CONSEQUENTLY THERE ARE MACHINES OPERATING TODAY WHICH DO NOT HAVE ADEQUATE OPENINGS TO HANDLE THE AMOUNT OF WATER BEING PULLED INTO THE BOX. THE PRESSURE DROP THROUGH THIS OPENING MAY AMOUNT TO THE EQUIVALENT OF 6" OF MERCURY. THIS CONDITION MAKES FOR AN UNEQUAL DISTRIBUTION OF VACUUM IN THE BOX ACROSS THE WIDTH OF THE MACHINE, WHICH MAY CAUSE BLOWING OR STREAKS IN THE SHEET, AS WELL AS HAVING THE SHEET WET ON THE BACK SIDE OF THE MACHINE.

THE AMOUNT OF VACUUM CARRIED IN THESE SUCTION BOXES VARIES WITH THE TYPE OF PAPER BEING MADE. SOME PAPER MAKERS FIND IT ADVISABLE TO CARRY A DIFFERENT VACUUM ON EACH BOX. PLEASE REFER TO SKETCH 1965 SHOWING TYPICAL ARRANGEMENT OF THESE SUCTION BOXES WITH PIPING AND VALVES ARRANGED SO THAT THE VACUUM MAY BE VARIED ON EACH INDIVIDUAL BOX. THE MINIMUM VACUUM FOR MAXIMUM WATER REMOVAL SHOULD BE CARRIED TO PROLONG WIRE LIFE. THE FIRST BOXES REMOVE THE GREATEST AMOUNT OF WATER; THE LAST OR DRY BOXES THEREFORE WILL HANDLE MORE AIR.

YOU WILL NOTE THAT THE WATER THROUGH EACH OF THESE BOXES IS CARRIED IN A BAROMETRIC LEG TO AN OPEN SEAL TANK OR TROUGH IN THE BASEMENT OF THE MILL. THE WHITE WATER IN THIS OPEN TANK IS USUALLY RETURNED TO THE SYSTEM, AS IT IS TOO VALUABLE TO WASTE. ELEVATIONS, SIZES OF PIPE, ETC., DEPEND UPON THE TYPE OF PRODUCT, WIDTH OF MACHINE, ETC., AND MUST BE SPECIFIED FOR EACH PARTICULAR APPLICATION. ON MOST GRADES OF PAPER THE QUANTITY OF AIR IS TOO GREAT TO BE HANDLED BY BAROMETRIC ACTION ALONE. THE PRESSURE DROP THROUGH A PIPE LINE CARRYING WATER AND AIR IS APPRECIABLY GREATER THAN WITH WATER OR AIR ALONE. IT IS ADVISABLE THEREFORE TO USE A VACUUM PUMP WITH A BAROMETRIC SYSTEM TO INSURE ADEQUATE WATER REMOVAL.

IN SOME MILLS THE SUCTION BOXES ARE CONNECTED TO A VACUUM PUMP WHICH ALSO SERVES SOME OTHER PART OF THE PAPER MACHINE. THIS IS NOT CONSIDERED GOOD OPERATING PRACTICE AS VACUUM CONTROL AT THE SUCTION BOXES IS MORE DIFFICULT. IF IT IS SATISFACTORY TO CARRY THE SAME VACUUM ON ALL OF THE SUCTION BOXES, A PIPING ARRANGEMENT SIMILAR TO THAT SHOWN ON SKETCH 1964 MAY BE USED. HERE AGAIN THE SIZE OF PIPE MUST BE SPECIFIED FOR EACH MACHINE.

BOTH OF THE PRECEDING ARRANGEMENTS ARE BASED ON THE ASSUMPTION THAT THE PAPER MILL HAS A BASEMENT OF SUFFICIENT DEPTH TO ALLOW FOR WATER REMOVAL FROM THE BOX BY BAROMETRIC SEPARATION. IF THE DESIGN OF THE PAPER MILL IS SUCH THAT A BAROMETRIC LEG ARRANGEMENT CANNOT BE USED, THEN IT BECOMES NECESSARY TO EMPLOY THE USE OF A SEPARATING TANK AND CENTRIFUGAL PUMP TO ACCOMPLISH THIS TASK AS THE AMOUNT OF WATER REMOVED IS TOO GREAT FOR THE VACUUM PUMP TO HANDLE. A CHECK VALVE SHOULD BE PLACED IN THE DISCHARGE LINE OF THE CENTRIFUGAL PUMP TO PREVENT THE VACUUM PUMP FROM PULLING IN AIR DURING THE START-UP PERIOD. GENERAL DETAILS OF SUCH AN INSTALLATION ARE SHOWN ON SKETCH 1958. IT WILL BE APPRECIATED, OF COURSE, THAT IF THIS WHITE WATER IS NOT REMOVED AHEAD OF THE VACUUM PUMP, NOT ONLY WILL MORE POWER BE CONSUMED, BUT THE PUMP IS LIABLE TO HAVE A SHORTER LIFE OWING TO CORROSION OR ABRASION IN HANDLING THE WHITE WATER WITH AIR.

THE AMOUNT OF VACUUM CARRIED ON THE SUCTION BOXES VARIES IN DIFFERENT INSTALLATIONS. THERE MAY BE ONLY 2" OF VACUUM IN SOME INSTANCES WHEREAS IN OTHER MILLS THIS MAY BE AS GREAT AS 10" OF MERCURY. THE LOAD ON THE WIRE AND THE FRICTION CAUSED BY THE MOVING WIRE ON THE STATIONARY BOXES IS DIRECTLY PROPORTIONAL TO THE AMOUNT OF VACUUM CARRIED. FOR THIS REASON IT IS BEST NOT TO HAVE THE VACUUM TOO HIGH AS IT WOULD CAUSE CONSIDERABLE WEAR

ON THE WIRE AND FURTHERMORE IT MAY BE IMPOSSIBLE TO DRIVE THE WIRE IF THE VACUUM IS TOO GREAT. SLIPPAGE AT THE COUCH, DUE TO TOO MUCH DRAG OVER THE FLAT BOXES, CAUSES EXCESSIVE WEAR OF THE WIRE AT THE COUCH ROLL.

DANDY ROLL

THE DANDY ROLL IS DESIGNATED AS SUCH PROBABLY BECAUSE OF ITS EFFECT UPON THE APPEARANCE ON THE FINISHED SHEET. THIS ROLL AS USED IN PRESENT-DAY MANUFACTURE PERFORMS TWO IMPORTANT FUNCTIONS; FIRST TO SMOOTH DOWN AND HARDEN THE SHEET; SECOND TO WATER-MARK THE SHEET.

THE SHAKE

AS THE FIBRES FLOW FROM THE HEAD BOX ON TO THE FOURDRINIER WIRE THEY MAY HAVE A NATURAL TENDENCY TO SET THEMSELVES WITH THEIR LENGTHS PARALLEL TO THE STREAM. IF THIS CONDITION WERE NOT CORRECTED, THE PAPER PRODUCED WOULD BE VERY WEAK WHEN TESTED AT RIGHT ANGLES TO ITS LENGTH. IT IS SOMETIMES NECESSARY TO PROVIDE SOME MEANS OF SHAKING THE WIRE SO THAT THE FIBRES WILL INTERMINGLE, THUS PRODUCING A SHEET OF PAPER WHICH IS MORE PROPERLY FELTED. THERE ARE A NUMBER OF METHODS USED TO PRODUCE THIS SIDE MOTION.

SUCTION COUCH ROLL

THE SUCTION COUCH ROLL CONSISTS OF A PERFORATED BRONZE SHELL. IT IS SO NAMED BECAUSE AT THIS POINT ON THE PAPER MACHINES THE SHEET OF PAPER IS STRONG ENOUGH TO CARRY ITS OWN WEIGHT. THE WORD "COUCH" COMES FROM THE FRENCH WORD "ACCOUCHER" SIGNIFYING BIRTH. IN THIS CASE IT SIGNIFIES THE BIRTH OF THE SHEET OF PAPER. THE SHEET OF PAPER, AFTER BEING CARRIED ALONG ON THE WIRE, PASSES OVER THE SUCTION COUCH ROLL. THIS COUCH ROLL CONTAINS A STATIONARY BOX WHICH IS SUPPORTED AGAINST THE INNER SURFACE OF THE REVOLVING SHELL AND IS SEALED WITH SPECIAL PACKING. A CONNECTION ON THE END OF THE SUCTION BOX INSIDE THE SURFACE OF THE REVOLVING COUCH ROLL IS PIPED TO A VACUUM PUMP. THE WIDTH OF THIS BOX IN THE SUCTION COUCH ROLL VARIES FROM 6" TO AS MUCH AS 16"; IN FACT ON SOME NEWSPRINT MACHINES A DOUBLE SUCTION BOX IS USED, THE FIRST COMPARTMENT BEING DESIGNED FOR LOW VACUUM AND THE SECOND COMPARTMENT FOR HIGH VACUUM. THE TOTAL WIDTH OF THESE TWO COMPARTMENTS MAY BE AS GREAT AS 21", WITH A VACUUM AS HIGH AS 24" BEING CARRIED ON THE SECOND OR DRY BOX. THE ADVANTAGE OF OPERATING SUCTION COUCH ROLLS UNDER A HIGH VACUUM IS AT PRESENT A CONTROVERSIAL SUBJECT AMONG MACHINE BUILDERS.

PRESS ROLLS

THE SHEET, AFTER LEAVING THE COUCH ROLL, PASSES TO THE PRESS SECTION. THIS IS USUALLY MADE UP OF ONE OR MORE SUCTION PRESS ROLLS AND ALSO PLAIN PRESS ROLLS. THE SHEET IS CARRIED ON ENDLESS WET WOOLEN FELTS FROM THE WIRE THROUGH THIS PART OF THE PAPER MACHINE. THE BOTTOM ROLL OF EACH SUCTION PRESS IS CONSTRUCTED SIMILAR TO A SUCTION COUCH ROLL, WITH A STATIONARY SUCTION BOX HELD NEXT TO THE INNER SURFACE OF THE SHELL. THIS BOX IS MUCH NARROWER THAN THE ONE USED IN THE SUCTION COUCH ROLL, USUALLY BEING ABOUT 4" IN WIDTH. WIDER BOXES AND DOUBLE BOXES ARE NOW BEING DEVELOPED. THEREFORE IN SELECTING A VACUUM PUMP FOR SUCTION PRESS ROLLS IT IS ADVISABLE TO INQUIRE INTO THE BOX WIDTH. THE PLAIN PRESS ROLLS OF COURSE DO NOT HAVE ANY SUCTION BOXES AS THEIR FUNCTION IS TO SMOOTH AND FLATTEN OUT THE SHEET OF PAPER BETWEEN THE TWO ROLLS BEFORE IT IS CARRIED TO THE DRYERS. THESE PRESS ROLLS, WHICH ARE SUPPORTED IN BEARINGS, ARE SUBJECT TO BENDING FROM THEIR OWN WEIGHT, AS WELL AS THE PRESSURE EXERTED UPON THEM. THEY ARE THEREFORE DESIGNED WITH A CROWN THAT IS LARGER IN DIAMETER AT THE MIDDLE THAN AT THE END AND GRADUALLY TAPERING FROM THE MIDDLE. THESE ROLLS ARE USUALLY RUBBER COVERED.

WET FELTS

THE WET FELTS PREVIOUSLY MENTIONED ARE USUALLY MADE OF WOOL. THEY ACT AS A CARRIER TO SUCCEEDING PARTS OF THE MACHINES AND ALSO AS A BLOTTER, ALLOWING WATER PRESSED FROM THE PAPER TO BE REMOVED.

DRYERS

THE FUNCTION OF THE DRYER SECTION OF THE PAPER MACHINE IS TO REMOVE THE MOISTURE FROM THE SHEET AFTER IT LEAVES THE LAST PAIR OF PRESS ROLLS. AT THIS POINT THE PAPER WILL CONTAIN 60 PERCENT TO 70 PER CENT OF WATER. THIS SECTION CONSISTS OF A SERIES OF HOLLOW CAST IRON CYLINDERS. STEAM IS ADMITTED TO THE REVOLVING CYLINDERS WHICH DRY THE SHEET. THE CONDENSATION IS REMOVED FROM THE CYLINDERS BY VARIOUS METHODS. [REDACTED] HAS BEEN MOST SUCCESSFUL IN MEETING THE REQUIREMENTS IN PAPER MILLS BY FURNISHING SPECIAL DRYER DRAINAGE EQUIPMENT FOR THIS APPLICATION.

CALENDERS

FROM THE DRYERS THE PAPER GOES TO THE CALENDER SECTION, WHICH IS A VERTICAL BANK OF HIGHLY POLISHED, CAST IRON ROLLS. THE PURPOSE OF THE CALENDERS IS TO GIVE A SMOOTH AND EVEN SURFACE TO THE PAPER.

REELS AND WINDERS

THE PAPER LEAVES THE CALENDERS AND IS WOUND ON REELS FROM WHICH IT GOES TO THE WINDER. THE PAPER IS THEN CUT BY A SLITTER AND WOUND INTO ROLLS OF THE DESIRED SIZE AND WIDTH FOR SHIPMENT.

CYLINDER MACHINE

A CYLINDER MACHINE LIKE THE FOURDRINIER IS DIVIDED INTO TWO MAIN SECTIONS - THE WET END AND THE DRY END. THE WET END OF THE CYLINDER MACHINE DIFFERS MATERIALLY FROM THAT OF THE FOURDRINIER IN CONSTRUCTION BUT THE DRY END IS ESSENTIALLY THE SAME.

THIS MACHINE GETS ITS NAME FROM THE FACT THAT A HORIZONTAL CYLINDER, HOLLOW IN THE CENTER, OPEN AT THE ENDS, AND COVERED WITH A WIRE CLOTH, REVOLVES PARTLY SUBMERGED IN A VAT OR TROUGH THROUGH WHICH PREPARED PULP IS CONTINUALLY CIRCULATED.

AS THE CYLINDER ROTATES, WATER FROM THE STOCK PASSES THROUGH THE WIRE MESH TO THE INTERNAL SECTION OF THE ROLL. THE FIBRES CLING TO THE OUTSIDE. THE HEAD CREATED BY THE DIFFERENCE IN ELEVATION BETWEEN THE STOCK LEVEL IN THE VAT AND THE LEVEL OF THE WATER INSIDE THE CYLINDER FORMS THE THIN WEB ON THE OUTSIDE SURFACES. THE WATER IS REMOVED FROM THE INTERNAL SECTION AT THE ENDS.

IT WAS DISCOVERED THAT TWO OR MORE LAYERS OF PAPER COULD BE BROUGHT TOGETHER BY MEANS OF ADDITIONAL CYLINDERS AND FORMED INTO A SINGLE SHEET. A SHEET OF PAPER MADE BY THIS METHOD HAS DESIRABLE QUALITIES DUE TO ITS LAMINATED STRUCTURE. FROM THIS FOLLOWED THE DEVELOPMENT OF THE PRESENT-DAY MULTI-CYLINDER MACHINE. THE CYLINDER MACHINES CAN THEREFORE BE CLASSIFIED INTO A SINGLE CYLINDER OR MULTI-CYLINDER TYPE.

COUCH ROLL

THE WEB IS CARRIED TO THE TOP OF THE CYLINDER AND THERE COMES IN CONTACT WITH AN ENDLESS TRAVELING WET FELT WHICH IS PRESSED AGAINST THE SURFACE OF THE REVOLVING CYLINDER BY MEANS OF A COUCH ROLL. THE FUNCTION OF THE COUCH ROLL ON A CYLINDER MACHINE IS DIFFERENT FROM THE SUCTION COUCH AS USED ON THE FOURDRINIER. SINCE A WET SHEET OF PAPER WILL ALSO STICK TO THE SMOOTHER SURFACE, THE WEB IS TRANSFERRED TO THE FELT. FROM HERE IT IS CARRIED ALONG THROUGH THE SUCTION OR PRESS ROLLS WHERE THE WATER IS REMOVED FROM THE FIBRES AND THE SHEET PRESSED INTO A FIRM MAT. THE SHEET IS THEN CARRIED THROUGH THE DRYER SECTION TO THE CALENDERS.

PLAIN PRESSES

TO FACILITATE WATER REMOVAL, THE FELT AND SHEET IS ALLOWED TO PASS THROUGH A SERIES OF SMALL PRESS ROLLS CALLED "BABY" PRESSES AND THENCE TO THE MAIN PRESSES WHERE THE MAIN PRESSURE IS APPLIED TO SQUEEZE OUT THE WATER.

PLAIN EXTRACTOR

A PLAIN EXTRACTOR HAS BEEN DEVELOPED WHICH IS PLACED ON THE CYLINDER MACHINE IMMEDIATELY FOLLOWING THE LAST COUCH. A SMALL ROLL IS PLACED ON TOP OF THE PLAIN EXTRACTOR, WITH THE SHEET AND FELT RUNNING BETWEEN. THIS COMBINATION MAY NOT REMOVE SUFFICIENT WATER AT HIGHER MACHINE SPEEDS; CONSEQUENTLY THE SUCTION EXTRACTOR WAS DEVELOPED. THIS IS A DRILLED BRONZE ROLL COVERED WITH WIRE MESH AND HAVING A SOFT RUBBER ROLL RIDING ON TOP. THE SHEET AND FELT PASS BETWEEN THESE ROLLS, THE SHEET BEING IN DIRECT CONTACT WITH THE WIRE MESH. A 4" SUCTION BOX IS SUPPORTED INSIDE THE PERFORATED PRESS ROLL AND IS CONNECTED TO A VACUUM PUMP. THIS ROLL REMOVES A GREAT QUANTITY OF WATER AND THEREFORE IT IS ADVISABLE TO USE SOME METHOD OF SEPARATION AHEAD OF THE VACUUM PUMPS.

SUCTION DRUM

ANOTHER DESIGN OF WATER REMOVAL EQUIPMENT CALLED THE "SUCTION DRUM" IS SOMETIMES USED IMMEDIATELY FOLLOWING THE LAST COUCH. THIS IS A DRILLED BRONZE ROLL HAVING A SUCTION BOX WITH WIDTHS FROM 14 TO 21". THE BOX IS ALSO CONNECTED TO A VACUUM PUMP. SEPARATION OF WATER AHEAD OF THE VACUUM PUMP IS RECOMMENDED.

SUCTION DRUM PRESS ROLL

THE SUCTION DRUM PRESS ROLL WAS LATER DEVELOPED, WHICH IS SIMILAR TO THE SUCTION DRUM BUT HAVING A HARD RUBBER ROLL RIDING ON TOP. TWO FELTS ARE USED WITH SUCTION DRUM PRESS, WITH THE SHEET BETWEEN.

SUCTION PRESS ROLL

THE CONSTRUCTION OF THE SUCTION PRESS ROLL AS USED ON THE CYLINDER MACHINE IS SIMILAR TO THE TYPE PREVIOUSLY DESCRIBED IN CONNECTION WITH THE FOURDRINIER.

SUCTION FELT BOXES

THESE BOXES ARE OF VARIED DESIGNS BUT ARE OFTEN SIMILAR TO A PIPE SECTION HAVING AN OPEN SLOT WITH ROUNDED EDGES 1/2" TO 5/8" WIDE OVER WHICH THE FELT TRAVELS. THESE BOXES EXTEND FOR THE FULL WIDTH OF THE MACHINE. ONE OR BOTH ENDS OF THESE BOXES ARE CONNECTED TO A VACUUM PUMP OR TO A BAROMETRIC LEG SEPARATION SYSTEM. IT IS ADVISABLE TO SEPARATE THE WATER AHEAD OF THE PUMP BECAUSE OF THE PIECES OF LINT AND OTHER FOREIGN PARTICLES EXTRACTED FROM THE FELT. THESE PARTICLES MAY BUILD UP IN THE VACUUM PUMP AND CAUSE EXCESSIVE WEAR IN THE CLEARANCES.

SUCTION FELT ROLLS

SUCTION FELT ROLLS ARE USED IN PREFERENCE TO FLAT BOXES AS THERE IS LESS WEAR ON THE FELTS. A STATIONARY BOX IS HELD INSIDE THE ROLL NEXT TO THE FELT AND THE WATER IS EXTRACTED BY MEANS OF APPLIED VACUUM. HERE AGAIN SEPARATION OF WATER AHEAD OF THE PUMP IS RECOMMENDED.

VICKERY CONDITIONERS

A FELT CLEANER WHICH MOVES BACK AND FORTH ACROSS THE FELT MAY BE USED ON ALL TYPES OF MACHINES. THESE ARE CALLED "VICKERY CONDITIONERS". THE NUMBER AND SIZE OF SHOES APPLIED DEPEND UPON THE SPEED AND WIDTH OF THE MACHINE, AS WELL AS THE PRODUCT MADE.

HARPER FOURDRINIER MACHINE

THE HARPER FOURDRINIER MACHINE CLOSELY RESEMBLES THE STANDARD FOURDRINIER MACHINE. THE ONLY DIFFERENCE IS IN THE WET END. THE WET END OF THE HARPER IS LIKE THAT OF THE FOURDRINIER EXCEPT THAT THE ENTIRE PORTION PRECEDING THE PRESS SECTION IS TURNED AROUND END FOR END. THE PAPER FORMED ON THE WIRE IS CARRIED BACK ON THE COUCH ROLL OR SUCTION ROLL ON A LONG FELT TO THE PRESS ROLLS. THE FELT IS CARRIED ON ROLLS HIGH OVER THE WIRE

AND SUPPORTS THE PAPER UNTIL IT ENTERS THE PRESSES AND IN SOME CASES UNTIL IT ENTERS THE DRYERS. THE FELT REQUIRED FOR THIS MACHINE IS OFTEN 100 FEET OR MORE IN LENGTH AND THIS MAKES IT DIFFICULT TO KEEP THE FELT FREE FROM INJURY. BECAUSE THERE ARE NO GAPS FOR THE SHEET TO BRIDGE AS BETWEEN THE COUCH ROLLS AND THE PRESSES IN THE STANDARD FOURDRINIER, ITS CHIEF USEFULNESS IS IN THE MANUFACTURE OF VERY DELICATE PAPERS SUCH AS TISSUES, CREPE, CIGARETTE, ETC. FREQUENTLY ONLY ONE SET OF PRESS ROLLS IS USED AS SUCH DELICATE PAPERS REQUIRE LITTLE PRESSING.

THE YANKEE MACHINE

THE CONSTRUCTION OF THE YANKEE MACHINE IS SIMILAR TO THE FOURDRINIER, CYLINDER OR THE HARPER IN THAT IT HAS ONE VERY LARGE DRYER ROLL WHICH IS ALSO USED IN FINISHING AND SURFACING, AS WELL AS DRYING THE SHEET OF PAPER. THE DRYER ROLL IS OFTEN TEN OR TWELVE FEET IN DIAMETER IN THIS COUNTRY AND IN EUROPE AS LARGE AS SEVENTEEN FEET IN DIAMETER. IT HAS A VERY HIGHLY POLISHED SURFACE AND THE SHEET OF PAPER IS PRESSED ON TO THIS SURFACE WHILE IT IS STILL WET BY MEANS OF A PRESSURE ROLL OR SUCTION PRESSURE ROLL. IN SOME INSTALLATIONS THE YANKEE DRYER HAS DUAL PRESSURE ROLLS WHILE IN OTHERS A COMBINATION PLAIN SUCTION ROLL AND SUCTION PRESSURE ROLL ARE USED WITH THE DRYER. THE WET END OF THE MACHINE IS VERY SIMILAR TO THE FOURDRINIER OR HARPER MACHINES - IN FACT THE YANKEE MACHINE RECEIVES THE NAME FROM ITS SPECIAL TYPE OF DRYER. THIS DRYER MAY BE USED IN CONJUNCTION WITH A PORTION OF A STANDARD DRYER SECTION OF A PAPER MACHINE OR THERE MAY EVEN BE TWO YANKEE DRYERS ON ONE MACHINE.

GENERAL ADVANTAGES CREDITED TO THE USE OF A YANKEE DRYER ON A PAPER MACHINE ARE:

- INCREASED DRYING CAPACITY PER SQUARE FOOT OF DRYER SURFACE
- IMPROVED FINISH
- IMPROVED QUALITY
- CREPING
- SMALLER MACHINE SPACE REQUIREMENTS, ETC.

THIS TYPE OF MACHINE IS PARTICULARLY ADAPTED TO THE MAKING OF THIN PAPERS SUCH AS TISSUE, MACHINE-GLAZED OR CREPE PAPERS.

GENERAL

THERE ARE MANY MODIFICATIONS IN THE DESIGN OF THE TYPES OF PAPER MACHINES PREVIOUSLY MENTIONED. THE METHODS OF MAKING PAPER ARE OF COURSE DEPENDENT ON SUCH THINGS AS THE AVAILABILITY OF RAW MATERIALS, POWER SUPPLY, MARKET CONDITIONS AND THE PERSONAL ELEMENT. FURTHERMORE PAPER MACHINE BUILDERS ARE CONTINUALLY EXPERIMENTING AND IMPROVING THE PERFORMANCE OF THE PAPER MACHINES.

APPLICATION

MANY FACTORS SUCH AS THE SPEED OF THE MACHINE, PRODUCTION RATE, KIND OF RAW MATERIALS, CHARACTERISTICS AND QUALITY OF THE PRODUCT, DESIGN OF THE MACHINE, AS WELL AS THE PERSONAL PRACTICES OF THE PAPER MILL OPERATING STAFF AFFECT THE FINAL SELECTION OF PUMPING EQUIPMENT. IN THIS CONNECTION YOU WILL FIND A FORM WHICH MAY BE USED IN TABULATING VACUUM PUMP DATA RELATING TO THE SIZE OF THE PUMP TO BE USED ON MISCELLANEOUS APPLICATIONS ON PAPER MACHINES. THE DATA COVERING ANY PARTICULAR APPLICATION SHOULD BE REFERRED TO THE FACTORY FOR CHECKING AS TO THE PROPER VACUUM PUMP SELECTION.

YOU WILL ALSO FIND A PAPER MILL QUESTIONNAIRE WHICH MAY BE OF SOME HELP IN RECORDING DATA FOR ANY PARTICULAR APPLICATION. IT WILL ALSO SERVE AS A GUIDE IN OBTAINING MILL DATA FOR FUTURE REFERENCE.

IT IS SUGGESTED THAT ALL THE INFORMATION POSSIBLE BE COLLECTED FOR EACH PAPER MACHINE IN YOUR TERRITORY FOR RECORD PURPOSES. WE WOULD BE PLEASED TO HAVE A COPY OF THIS INFORMATION FOR OUR FILES NOT ONLY FOR FUTURE REFERENCE BUT TO ENABLE US TO MAKE STUDIES OF ALL POSSIBLE PHASES OF THE APPLICATION OF OUR PRODUCTS TO THIS IMPORTANT INDUSTRY.

WATER REMOVAL EQUIPMENT

THE CONSTRUCTION DETAILS AND LOCATION OF WATER REMOVAL EQUIPMENT VARIES WITH THE TYPE OF PAPER MACHINE AND THE PRODUCT BEING MADE. SIMPLIFIED SKETCHES OF SOME OF THE MORE IMPORTANT EQUIPMENT DESIGNED FOR WATER REMOVAL ARE ATTACHED.

SEVERAL DRAWINGS ARE ATTACHED SHOWING THE GENERAL ARRANGEMENT OF ACCESSORY EQUIPMENT AND PIPING ARRANGEMENTS USUALLY INSTALLED WITH  VACUUM PUMPS. COMMENTS ON THESE SKETCHES FOLLOW:

B-7424 - SEPARATING PUMP ARRANGEMENT

WHEN PUMPING FROM A TANK UNDER VACUUM, IT IS NECESSARY TO INSTALL A CENTRIFUGAL REMOVAL UNIT. THE  CENTRIFUGAL REMOVAL PUMP IS SPECIALLY DESIGNED FOR THIS SERVICE, HAVING FEATURES WHICH PREVENT AIR BINDING. THE SUCTION CONNECTION CAN BE ROTATED TO A VERTICAL AS WELL AS A HORIZONTAL POSITION. IT IS PREFERABLE TO INSTALL THE PUMP DIRECTLY BENEATH THE TANK, WITH THE SUCTION NOZZLE IN A VERTICAL POSITION, AS SHOWN IN THE VIEW ON THE RIGHT SIDE OF THE DRAWING REFERRED TO ABOVE. WITH THIS ARRANGEMENT THE VAPORS OR ENTRAINED AIR MAY BE LIBERATED READILY THROUGH THE NOZZLES BACK INTO THE TANK. IF IT IS NECESSARY TO MOUNT THE PUMP AT THE SIDE OF THE TANK, A VENT CONNECTION SHOULD BE PIPED FROM THE SUCTION PASSAGES SO THAT ANY ENTRAINED VAPORS MAY BE VENTED BACK TO THE TANK AND SO PREVENT THE PUMP FROM BECOMING VAPOR BOUND. IN THESE TYPES OF INSTALLATIONS IT IS RECOMMENDED THAT THE STUFFING BOX BE PROVIDED WITH A LANTERN GLAND AND SEALED WITH CLEAR WATER FROM AN INDEPENDENT SUPPLY. A CHECK VALVE SHOULD BE PLACED ON THE CENTRIFUGAL TO PREVENT THE VACUUM PUMP FROM PULLING IN AIR DURING THE START-UP PERIOD.

SKETCH 1958 - SEPARATING TANK ARRANGEMENT

IN CASES WHERE IT IS NECESSARY TO SEPARATE THE WATER AHEAD OF THE VACUUM PUMP, IT IS OFTEN ADVANTAGEOUS TO SUSPEND THE TANK UNDERNEATH THE MACHINE ROOM FLOOR TO SUIT THE PARTICULAR INSTALLATION SO THAT THE CENTRIFUGAL PUMP WILL HAVE SUFFICIENT SUCTION HEAD. THE WATER AND AIR ARE CARRIED TO THE TANK WHERE SEPARATION TAKES PLACE, THE WHITE WATER BEING HANDLED BY A CENTRIFUGAL PUMP ESPECIALLY DESIGNED FOR THIS SERVICE. THIS CENTRIFUGAL PUMP CAN RETURN THE WHITE WATER TO THE SYSTEM OR TO THE SEWER, AS REQUIRED. WHEN IT IS DESIRED TO LOCATE THE VACUUM PUMP ON THE MACHINE ROOM FLOOR IT IS OFTEN BETTER TO INSTALL THE TANK WITH THE TOP SECTION ABOVE THE FLOOR AND THE LOWER SECTION EXTENDING THROUGH THE FLOOR TO THE ROOM BELOW.

WITH THIS ARRANGEMENT THE PIPE FROM THE SUCTION ROLL MAY BE RUN EITHER ALONG THE FLOOR OR IMMEDIATELY BELOW THE FLOOR INTO THE TANK. THE AIR PIPING IS CARRIED FROM THE TOP OF THE SEPARATING TANK TO THE VACUUM PUMP AND THE WATER PIPING EXTENDS FROM THE BOTTOM OF THE TANK TO THE CENTRIFUGAL PUMP BELOW. SEPARATION IS NECESSARY WHEN THE QUANTITY OR QUALITY OF WATER WOULD BE DETRIMENTAL TO THE OPERATION OF THE VACUUM PUMP.

SKETCH 1964 - BAROMETRIC SEPARATION

THE MOST SATISFACTORY METHOD OF HANDLING WATER FROM SUCTION BOXES SERVING THE FOUR-DRAINER WIRE OR THE FELTS ON A PAPER MACHINE IS BY MEANS OF BAROMETRIC SEPARATION. ON THE SKETCH REFERRED TO ABOVE YOU WILL NOTE THAT ALL OF THE WATER COMING FROM THE WIRE OR FELT BOXES IS PIPED TO A COMMON MANIFOLD WHICH CARRIES THE WATER TO A BAROMETRIC LEG HAVING ITS OUTLET IN A BOX IN THE BASEMENT OF THE MILL. THE WHITE WATER FROM THE SEAL BOX MAY BE RETURNED TO THE SYSTEM OR ALLOWED TO SPILL INTO THE SEWER, WHICHEVER IS DESIRED.

THE RISER PIPE "A" WHICH IS CONNECTED TO TEE "D" IS OF AMPLE SIZE TO ALLOW THE AIR TO DISCHARGE UPWARD AND THENCE TO THE VACUUM PUMP. A VACUUM RELIEF VALVE SET AT THE RE-

REQUIRED OPERATING VACUUM SHOULD BE INSTALLED AT A CONVENIENT LOCATION IN THE PIPE LINE LEADING TO THE VACUUM PUMP. THE RELIEF VALVE PREVENTS THE VACUUM PUMP FROM PULLING AN EXCESSIVE VACUUM ON THE SHEET OF PAPER AND ALSO ELIMINATES THE POSSIBILITY OF THE PUMP OVERLOADING AS WELL AS RUINING THE WIRE OR FELT. THIS PIPING ARRANGEMENT IS NOT POSSIBLE, OF COURSE, WHERE THERE IS NO BASEMENT. PROPER DIMENSIONS FOR THIS PIPING CAN BE FURNISHED FOR EACH INSTALLATION.

SKETCH 1965 - BAROMETRIC SEPARATION

IN A NUMBER OF MILLS IT IS DESIRED TO OPERATE WITH VARYING VACUUMS ON THE FLAT BOXES. THE PRINCIPLE OF OPERATION UNDER THIS ARRANGEMENT IS VERY SIMILAR TO THAT SHOWN ON SKETCH 1964, THE ONLY DIFFERENCE BEING IN THE INDIVIDUAL BAROMETRIC LEG FEATURES. HERE YOU WILL NOTE THAT A CONTROL VALVE IS INSTALLED IN EACH RISER PIPE BETWEEN THE BOX AND THE COMMON AIR HEADER LEADING TO THE VACUUM PUMP. BY MEANS OF THIS VALVE A PREDETERMINED VACUUM CAN BE CARRIED ON EACH BOX, WITH THE MAXIMUM VACUUM OF THE SYSTEM BEING HELD IN THE MAIN SUCTION LINE LEADING TO THE PUMP. HERE AGAIN SIZES WILL BE RECOMMENDED FOR EACH PAPER MILL INSTALLATION. SOME INSTALLATIONS USE A BAROMETRIC SEPARATION SYSTEM WITHOUT A VACUUM PUMP. WITH SUCH AN ARRANGEMENT THERE IS LIKELY TO BE SURGING IN THIS BAROMETRIC PIPING FROM THE ACTION OF THE COMBINED AIR AND WATER AND THE VACUUM WILL BE LOW AND UNEVEN. THIS OF COURSE MIGHT HAVE A DIRECT EFFECT ON THE SHEET CAUSING STREAKS AS WELL AS BREAKS.

B-7331 - SEPARATING TANK

THE ABOVE DRAWING SHOWS GENERAL DIMENSIONS OF A NEW TYPE OF TANGENTIAL TANK WHICH IS RECOMMENDED FOR VACUUM PUMP INSTALLATIONS REQUIRING SEPARATION. THE TANK DESIGN PROVIDES BETTER SEPARATION OWING TO THE TANGENTIAL STREAM OF AIR AND WATER AS IT ENTERS THE TANK. THE OUTLET CONNECTION IS LOCATED ON THE BOTTOM AND NEAR THE SIDE OF THE TANK. THIS CONSTRUCTION PROVIDES MORE ROOM FOR WORKING ON THE CENTRIFUGAL PUMP, WHICH IS PLACED DIRECTLY BENEATH THE TANK OUTLET CONNECTION. IT ALSO REQUIRES LOWER SUBMURGENCE BECAUSE THE OUTLET IS FURTHER FROM THE CENTER OF ANY VORTEX WHICH MAY DEVELOP INSIDE THE TANK.

D-9098 - LIFT FITTING

IN SOME INSTALLATIONS IT IS NECESSARY TO USE A RISER PIPE TO THE TANK INLET. HERE WE RECOMMEND THE USE OF A LIFT FITTING, DETAILS OF WHICH ARE INDICATED ON THE ABOVE DRAWING. WITH THIS ARRANGEMENT A STEADY FLOW OF AIR AND WATER TO THE TANK IS ASSURED. THESE FITTINGS CAN BE MADE UP BY THE CUSTOMER BUT WE WILL GLADLY FURNISH THE SIZES NECESSARY. THIS ARRANGEMENT SHOULD ONLY BE USED WHEN IT IS IMPOSSIBLE TO HAVE GRAVITY FLOW AS THE LIFT CAUSES A LOSS IN VACUUM, THE AMOUNT OF LOSS DEPENDING ON THE NET LIFT AND THE QUANTITY OF WATER HANDLED.

BIRD MACHINE COMPANY DRAWING VCJP-2/6

THIS DRAWING WAS PREPARED IN COLLABORATION WITH [REDACTED] COMPANY AND WILL BE OF ASSISTANCE IN SELECTING VACUUM PUMPS FOR VICKERY CONDITIONERS.

Approved For Release 1999/09/10 : CIA-RDP83-00423R001000470002-7

LOCATION

PERSONNEL: MANAGER
CHIEF ENGINEER
PAPER MILL SUPERINTENDENT

MACHINE DATA: TYPE (FOURDRINIER, CYLINDER, YANKEE, ETC.)

MACHINE BUILDER

WIDTH IN INCHES

SPEED IN FEET PER MINUTE

PRODUCT

DOES MILL HAVE A BASEMENT? IF SO GIVE DEPTH.

PUMP APPLICATION

WIRE BOXES: Box WIDTH

NUMBER OF BOXES

TYPE OF SEPARATION - BAROMETER OR TANK

VACUUM CARRIED ON BOXES

DOES CUSTOMER DESIRE MULTIPLE DROP LEG ARRANGEMENT FOR INDIVIDUAL CONTROL?

SUCTION COUCH ROLL: MAKE

DIAMETER OF ROLL

WIDTH OF BOX

VACUUM REQUIRED

SUCTION PRESS ROLL: MAKE

DIAMETER OF ROLL

WIDTH

VACUUM REQUIRED

FELT BOXES: WIDTH OF SLOT IN BOX

STATE WHETHER ON OPEN FELT, SINGLE FELT AND SHEET
OR TWO FELTS AND SHEET

SUCTION EXTRACTOR, SUCTION DRUM, FELT ROLL, ETC.: DIAMETER OF ROLL

WIDTH OF BOX

VACUUM REQUIRED

VICKERY CONDITIONERS: SIZE OF SHOES

NUMBER OF SHOES

VACUUM REQUIRED

USED ON WHICH FELT

SUCTION SLICE: WIDTH OF SLOT

WHERE USED

CURRENT CHARACTERISTICS

SEAL WATER: TEMPERATURE AND QUALITY OF WATER USED FOR SEALING PUMPS

DRYER DRAINAGE: WHICH SYSTEM IS NOW BEING USED?

Approved For Release 1999/09/10 : CIA-RDP83-00423R001000470002-7

HEIGHT OF LIQUID "A" DEPENDS ON VACUUM
INSIDE OF TANK AS WELL AS VAPOR PRESSURE
AND CHARACTERISTICS OF LIQUID.

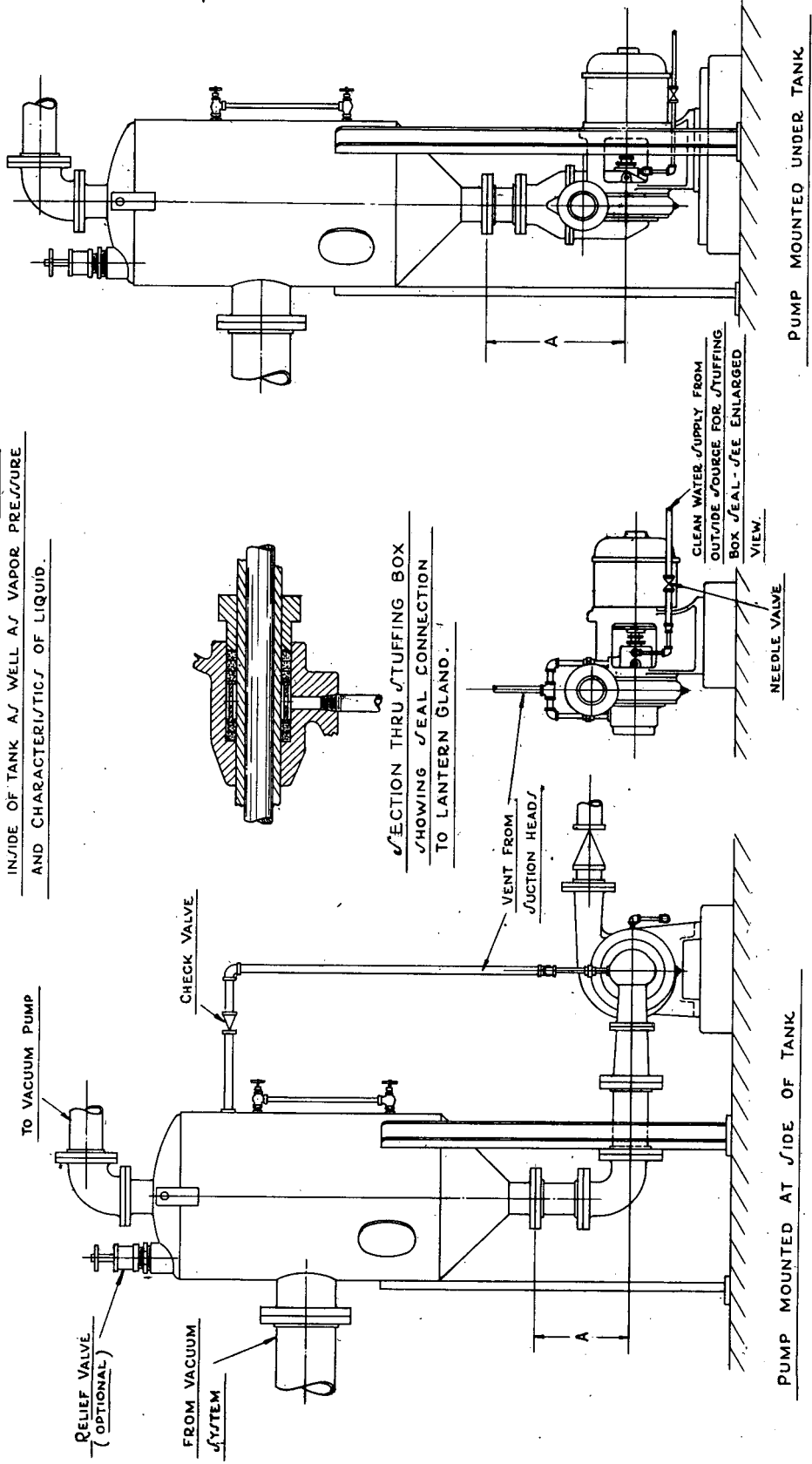

PUMP MOUNTED UNDER TANK

PUMP MOUNTED AT SIDE OF TANK

DO NOT SCALE. REFER ALL REFERENCES TO FIG. NO. THROUGH FACTORIAL REFERENCES FOR PARTS.

G	SCALE	DRWN	TRCD	CH'G'D	APPR'D	BY	NO.
F							
E							
D							
C							
B							

TITLE: TYPICAL ARRANGEMENTS SHOWING METHODS OF CONNECTING CENT. PUMP TO SEPARATING TANKS & VAC. SYSTEM
 No. B-7424

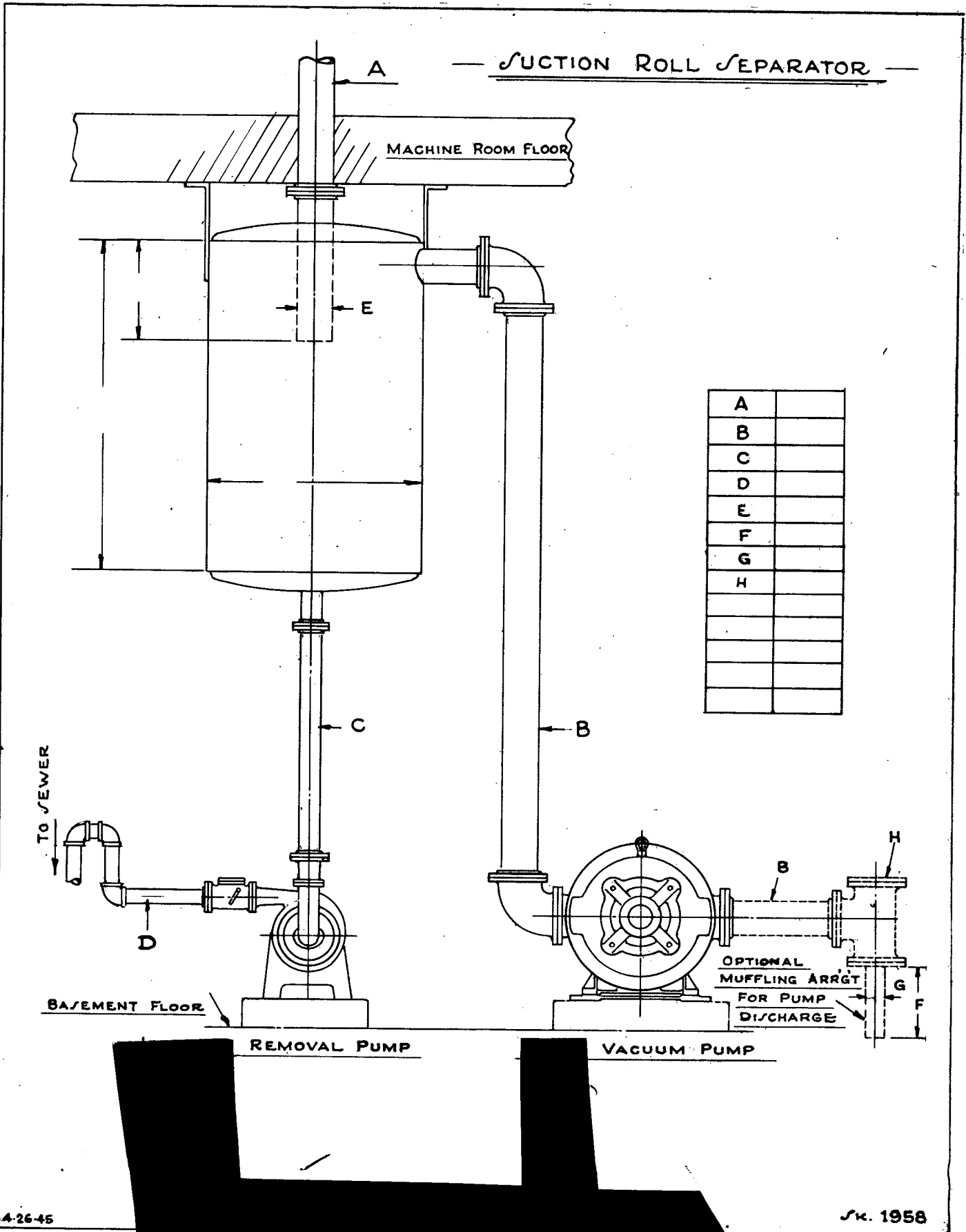

A-26-45

SK. 1958

**BELFIELD RELIEF VALVE SETTING
CORRESPONDS TO THE AVAILABLE
LENGTH OF DROP LEG**

**FLAT BOXES ON THE
WIRE, FELT BOXES OR
CONDITIONERS**

**NOT LESS
THAN 6 FEET**

**H - MUST BE 3 FEET
GREATER THAN THE
VACUUM EXPRESSED
IN INCHES OF MERCURY**

**BAROMETRIC SEPARATION OF FLAT BOX RETURNS
WITH SINGLE LEG & SEAL BOX**

SK-1964

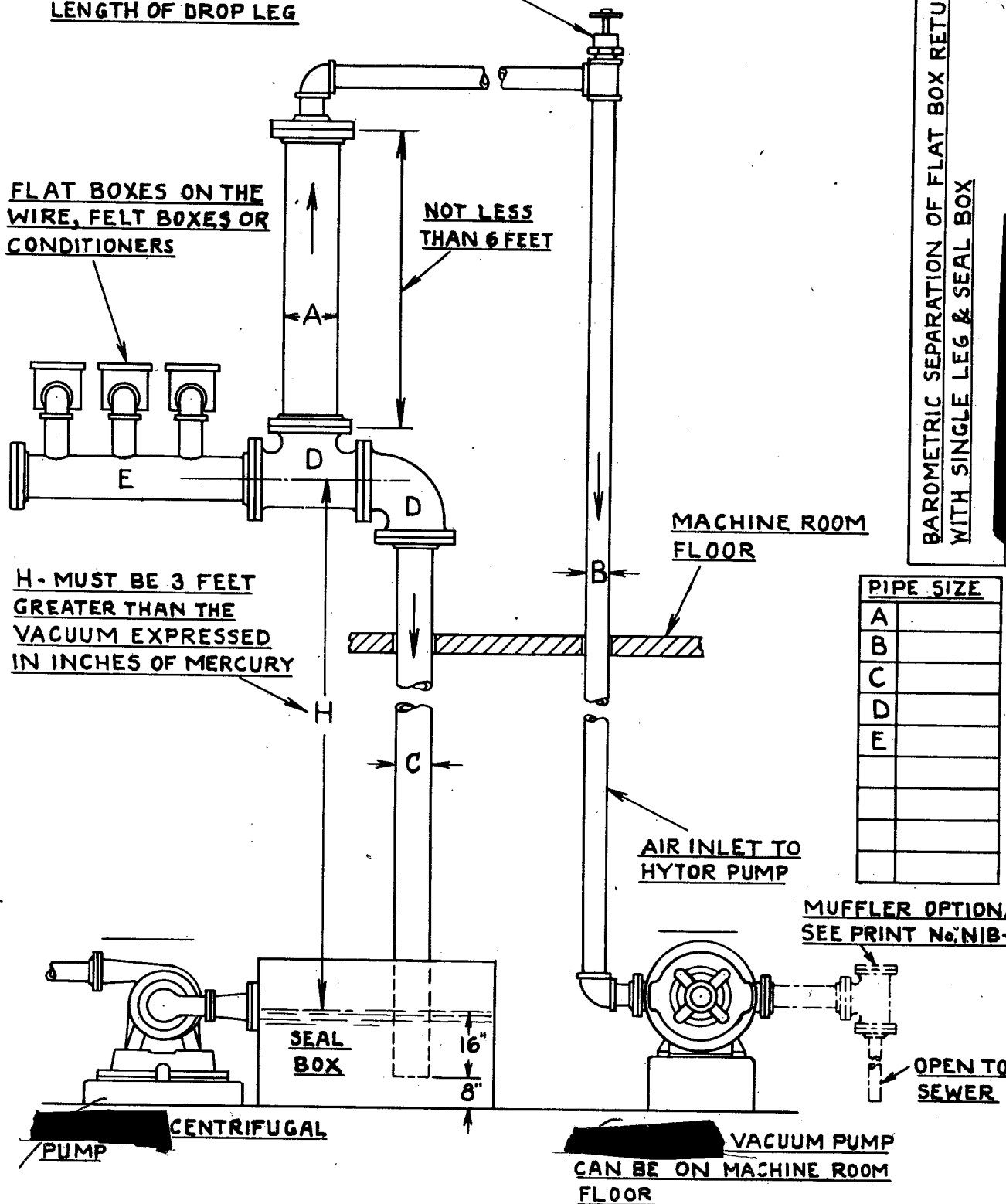

PIPE SIZE	
A	
B	
C	
D	
E	

**MUFFER OPTIONAL
SEE PRINT No. NIB-11B**

**CENTRIFUGAL
PUMP**

**VACUUM PUMP
CAN BE ON MACHINE ROOM
FLOOR**

**OPEN TO
SEWER**

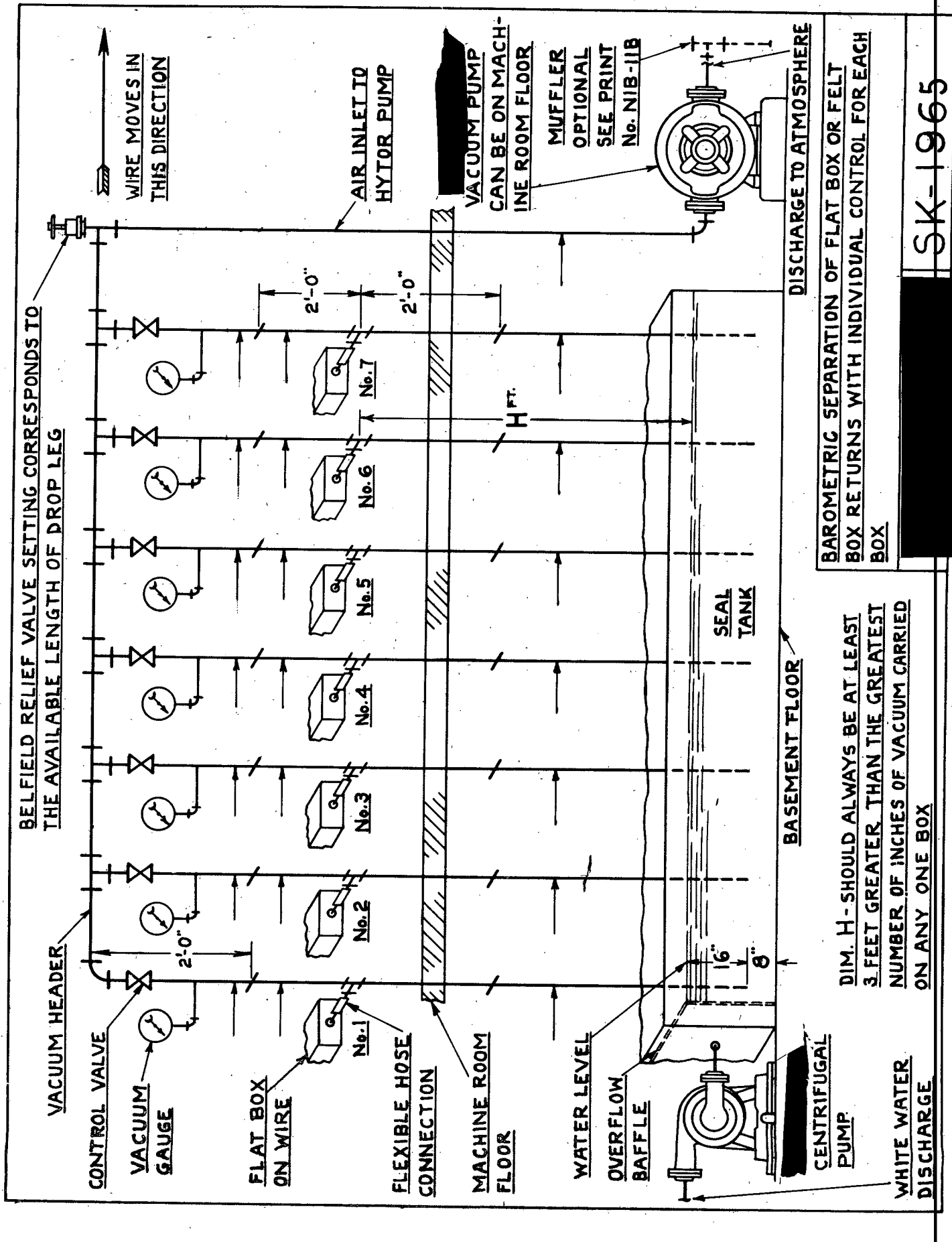

SK-1965

A.
B-7331

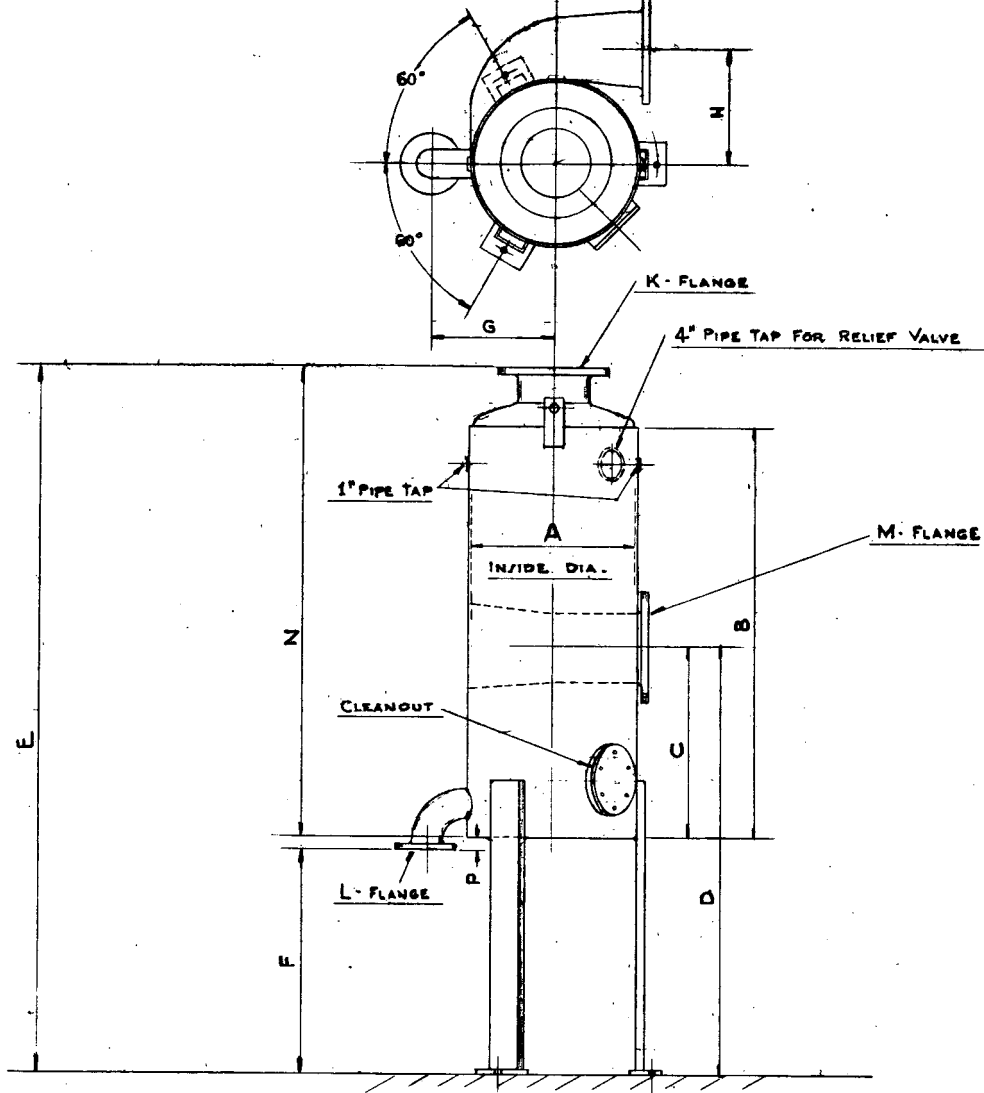

DIMENSION/ - SEPARATING TANKS - TYPE T

JAN-22-46

TANK DIMENSION/ IN INCHES/														
PUMP SIZE	A	B	C	D	E	F	G	H	J	K	L	M	N	P
L5 & L6	16	54	24				13 ³ / ₄	10 ³ / ₄	9	6x11	4x9	6x11	61	2 ¹¹ / ₁₆
L7 & L8	24	72	27				20 ¹ / ₄	16 ³ / ₈	12	10x16	6x11	10x16	80	4
L9	30	84	30				23 ¹ / ₂	20 ⁷ / ₁₆	14	12x19	6x11	12x19	94	4 ¹ / ₂
L10	36	84	36				29 ¹ / ₄	24 ⁵ / ₈	18 ¹ / ₂	14x21	8x13 ¹ / ₂	14x21	95	5 ¹ / ₂
	48	108	42				35 ¹ / ₂	32 ¹ / ₂	24 ¹ / ₂	20x27 ¹ / ₂	8x13 ¹ / ₂	20x27 ¹ / ₂	123	5

NOTE: ALL PIPING CONNECTION DIMENSION/ APPROXIMATE
SIZES/ OF TANK/ CORRESPONDING TO VACUUM PUMPS SHOWN
ARE FOR SUCTION ROLL SERVICE ONLY.

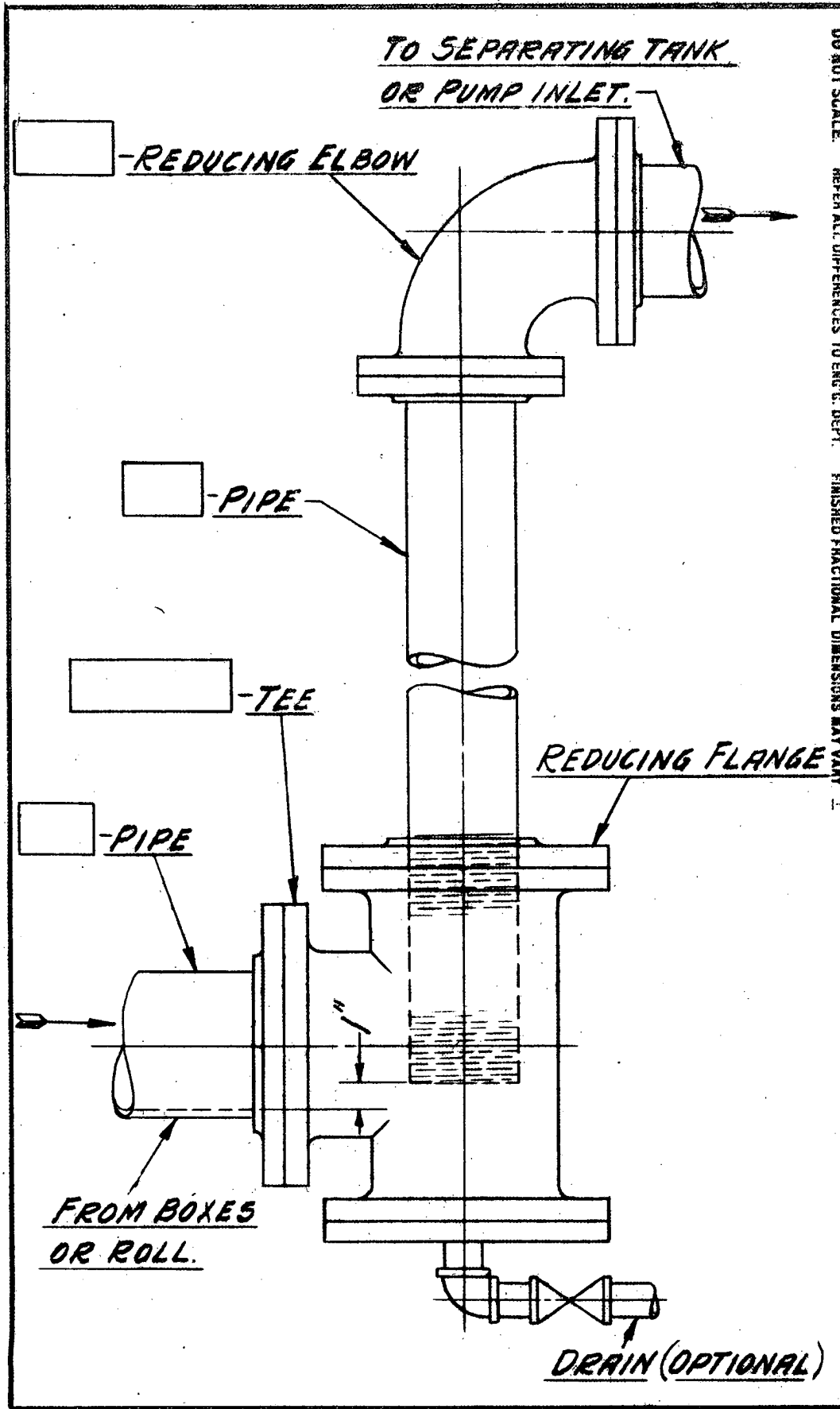

DO NOT SCALE. REFER ALL DIFFERENCES TO ENGR. DEPT. FINISHED FRACTIONAL DIMENSIONS MAY VARY ±

LIFT FITTING DETAIL				REVISIONS																			
SCALE	DRAWN	DATE	CHK'D	DATE	REVIS.	ION NO.																	
3/4"	JEM	4-30-57	EJM	4-30-57																			
D-9098							E	WAS	DE	BY	F	L											
							A				G	M	N										
							B				H	O											
							C				I	P											
							D				J												
							E				K	O											

