

FORM NO. 51-4AA
FEB 1952

CENTRAL INTELLIGENCE AGENCY

CLASSIFICATION

SECRET
SECURITY INFORMATION

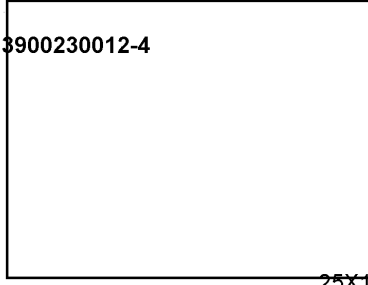

25X1

INFORMATION REPORT

REPORT NO.

CD NO. 25X1

COUNTRY USSR (Moscow and Kalinin Oblasts)

DATE DISTR. 30 Sept. 1952

SUBJECT Activities at Podlipki and Gorodomliya of
German Scientists from Institute Rabe in Bleicherode

NO. OF PAGES 1

25X1 DATE OF INFO.

NO. OF ENCLS. 1 (7 pages)
(LISTED BELOW) 25X1

PLACE ACQUIRED

SUPPLEMENT TO REPORT NO.



OF THE UNITED STATES, WITHIN THE MEANING OF TITLE 18, SECTIONS 793 AND 794, OF THE U.S. CODE, AS AMENDED. ITS TRANSMISSION OR REVELATION OF ITS CONTENTS TO OR RECEIPT BY AN UNAUTHORIZED PERSON IS PROHIBITED BY LAW. THE REPRODUCTION OF THIS FORM IS PROHIBITED.

THIS IS UNEVALUATED INFORMATION.

25X1



RETURN TO RECORDS CENTER
IMMEDIATELY AFTER
JOB 56-372 BOX 19

23780

CLASSIFICATION

SECRET

STATE	<input checked="" type="checkbox"/>	NAVY	<input checked="" type="checkbox"/>	NSRB		DISTRIBUTION										
ARMY	<input checked="" type="checkbox"/>	AIR	<input checked="" type="checkbox"/>	FBI		ATTC	<input checked="" type="checkbox"/>									

Incl 18

157-10180-R

SECRET
SECURITY INFORMATION

25X1

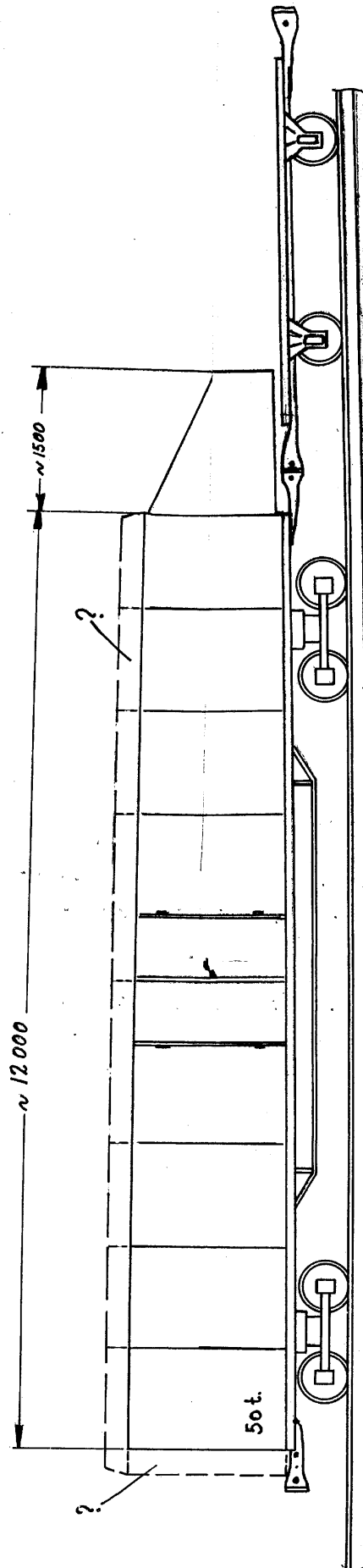

RAILROAD CAR (1950) - PODLIPKI
SEEN AT PODLIPKI - USSR
Enclosure (C)

SECRET
SECURITY INFORMATION

25X1

Approved For Release 2006/03/03 : CIA-RDP82-00457R013900230012-4

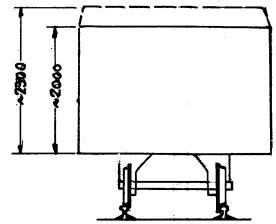
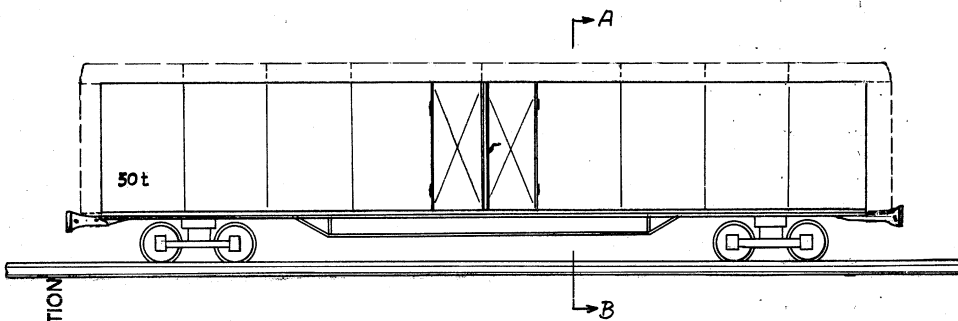

SECRET
SECURITY INFORMATION

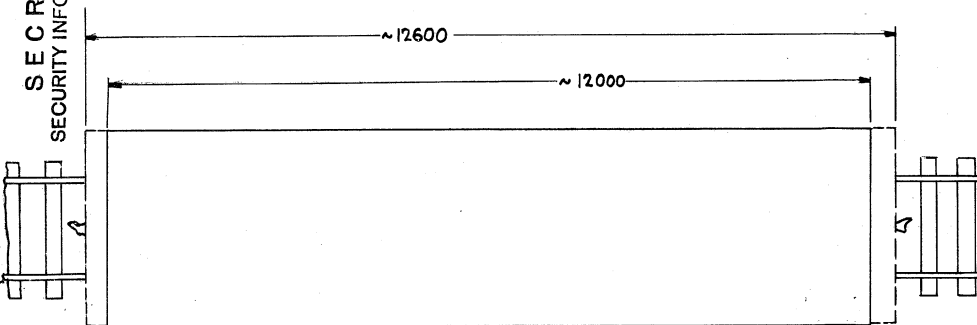

RAILROAD CAR FOR V-2 ROCKETS
Observed at PODLIPKI-USSR
Enclosure (B)

SECRET
SECURITY INFORMATION

Approved For Release 2006/03/03 : CIA-RDP82-00457R013900230012-4

SECRET
SECURITY INFORMATION

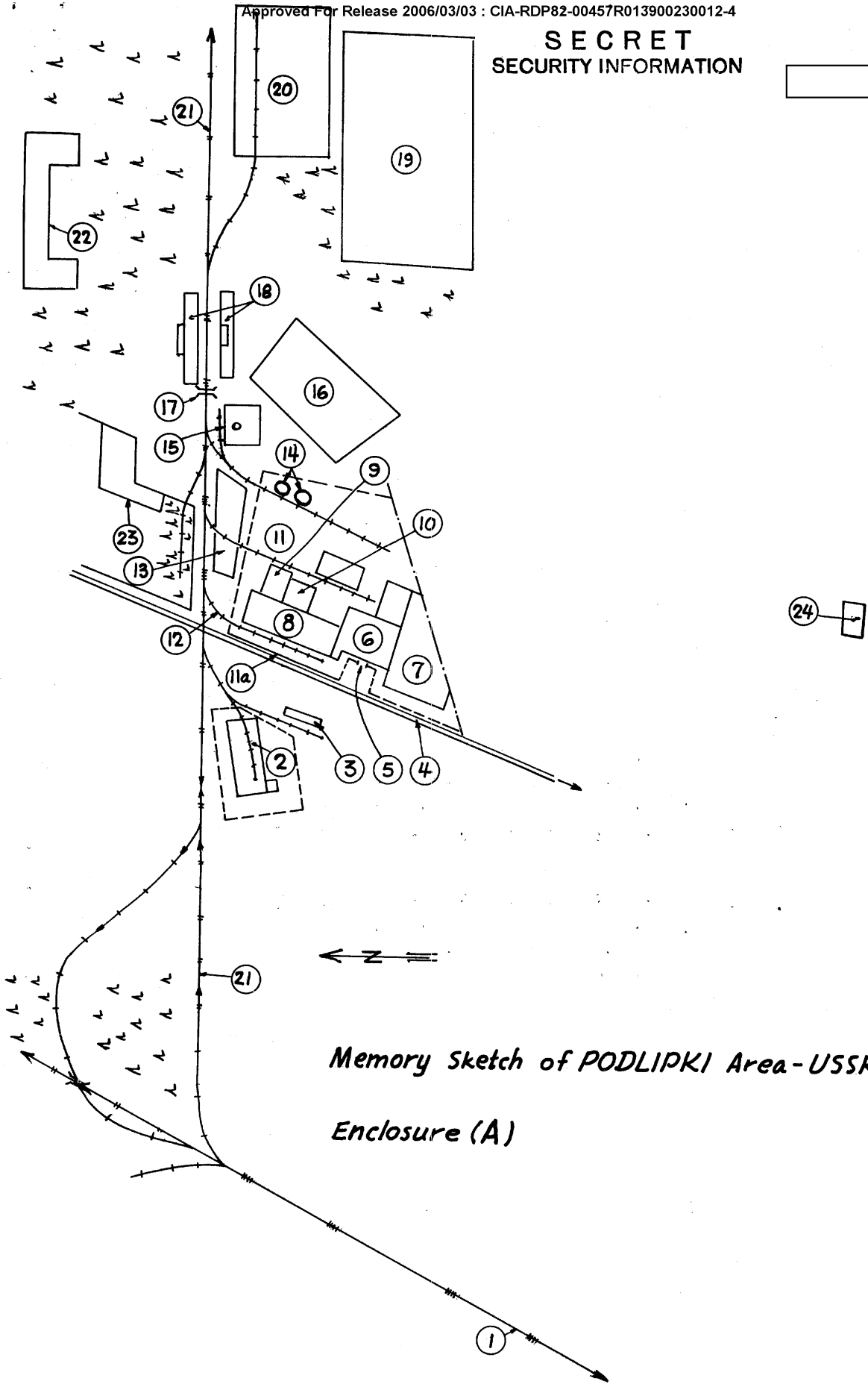
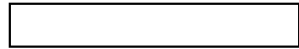

Memory Sketch of PODLIPKI Area-USSR

Enclosure (A)



SECRET
SECURITY INFORMATION

Next 1 Page(s) In Document Exempt

SECRET

25X1

[REDACTED]
 dated 1st September, 1952.
Page No. 1.

GUIDED MISSILES

1. The following details were obtained in connection with the Activities of Zavod 88, (PODLIPKI) and FILIALE WERK 88 (on the Island GORODOMLJA in Lake SEELIGER, near OSTASCHKOV.

Zavod 88

- (a) The BLEICHERODE group were only allowed in one building of the PODLIPKI complex.
- (b) No research or production machinery in the building used by the BLEICHERODE group.
- (c) Work consisted in the writing of technical reports in connection with the V-1, V-2, Wasserfall, and Schmetterling type weapons.
- (d) By May 1948 this whole group had moved to OSTASCHKOV.

FILIALE WERK 88 (OSTASCHKOV) (Fig. 1 refers)

- (a) No weapon productions took place here.
- (b) It is known that the Aerodynamic department contained a wind tunnel and a water channel.
- (c) From time to time small conical shaped models were sent from PODLIPKI to the Aerodynamic department at OSTASCHKOV for test in the water channel and wind tunnel.
- (d) Models were sometimes prepared at OSTASCHKOV.
- (e) Very frequently an aircraft (type unknown) circled the island. It was generally understood at OSTASCHKOV that the circling aircraft had some connection with the work of the High Frequency department.
- (f) In June or July 1951, the Russians declared officially that the work of the island was no longer secret.

Personnel Movements in Russia. (For detailed list of personnel refer STIB Report No. 69.)

- 2. On the 22nd October 1946, [REDACTED] all members of the Institute RABE (BLEICHERODE) was transported to Russia. 25X1
- 3. They were accommodated at PUSHKINO (a northern suburb of MOSCOW) in a convalescent home, and until November 1946 they did no work.
- 4. Sometime in November 1946 they were detailed to work in the Institute 88 at PODLIPKI, and were allotted a building in the PODLIPKI complex; they travelled between PUSHKINO and PODLIPKI by omnibus daily.

SECRET

-3-

757-101804

SECRET

25X1

[REDACTED]
 dated 1st September, 1952.
Page No. 2.

5. Immediately after arrival in PODLIPKI about 50 personnel were transferred to OSTASCHKOV, including the following:-

Prof. FRIESER
 " PAUR
 Dr. SCHWARZ
 Dr. STRZELBA
 Dr. REICHARDT
 Dip. Ing. SHOEFFMANN
 Ing. SCHOLTZ
 Fritz SCHRADER

6. In the first half of 1948, the remaining personnel at PODLIPKI were transferred in two groups to OSTASCHKOV, the last group, [REDACTED] left for OSTASCHKOV in May 1948.

7. During 1950, six persons were sent from OSTASCHKOV to an unknown destination (now known to be Postfach 908 - [REDACTED])

8. In June 1952, approx. 105 specialists and families returned to the ROZ of Germany, in two transport groups.

9. [REDACTED] approx. 25 specialists with families are still at OSTASCHKOV, although she believed at the time of the departure of the 1st and 2nd transports that the third transport would soon follow.

Activities of Zavod 88

10. The group were all contained in one building in the PODLIPKI complex, and no practical work of any nature was carried out by any member of the group.

11. The building itself was divided into a number of (a) general offices, (b) drawing offices.

12. The organizing head of this group was Dipl. Ing. GRÖTTRUP who was the only person in the group allowed out of the PODLIPKI complex. He was understood to have made several trips to OSTASCHKOV. (Even when GRÖTTRUP moved to OSTASCHKOV in 1948, he occasionally made journeys to an unknown destination. It was rumoured that he went to PODLIPKI. Other personnel were only allowed to leave the island to visit OSTASCHKOV in order to buy fresh meat, and even then they were accompanied by Russians.)

13. The work of the group was confined to the writing of reports concerning their previous work in Germany, and to producing drawings of the V-1, V-2, Wasserfall and Schmetterling type weapons, and/or parts thereof, and associated equipment.

14. The equipment contained within the building consisted of:-

- (a) General office equipment.
- (b) Slide rules and electrical calculating machines.

SECRET

-4-

SECRET

25X1

SECRET[REDACTED]
dated 1st September, 1952.

Page No. 3.

15. Before the first group was transferred to OSTASCHKOV approx. 130 specialists were employed in this building at PODLIPKI.

16. The Russian in charge of the building was Col. POBEDONOSOV, who had been seen previously in BLEICHERODE.

Activities of FILIALE WERK 88 (OSTASCHKOV) (Fig. 1)

17. By May 1948 the whole of the PODLIPKI group had been transferred to OSTASCHKOV, and Frau QUOOS was in the last transport.

18. All German personnel she met on arrival at OSTASCHKOV she had met before at PODLIPKI.

19. There was one main building on the island which formed the complete technical accommodation for the OSTASCHKOV group. Rumour had it that this building was originally put up by the British or the Americans as a Bacteriological Institute for the study of 'horse diseases' (Pferdekrankheiten).

20. Later the building fell into disuse, and after a period of years the site was levelled, and the existing building erected.

21. The building was split into five Sections and two Departments, viz:-

Section 1 - Ballistics	under Dr. WOLFF
" 2 - Aerodynamics	" Dr. ALBRING
" 3 - Thermodynamics (Wärmetechnik)	" Dr. UMFENBACH
" 4 - H.F. and Control	" Ing. Gerd MÜLLER
" 5 - Design Office	" Dipl. Ing. BLAS
Chemical Dept.	" Dr. MATHIAS
Building "	" JAFFKE

Each section or department was considered as one independent unit, and non-specialist personnel from one section were not allowed to visit any other. Until June or July 1951 the work carried out at OSTASCHKOV was secret. After June or July 1951 the work at OSTASCHKOV was officially declared to be no longer secret.

25X1

SECRET**SECRET**

SECRET

[Redacted]

25X1

dated 1st September, 1952.
Page No. 4.

Details of the Aerodynamic Section at OSTASCHKOV

25. [Redacted] the aerodynamic section contained the following items:-

- (a) Water channel - approx. $\frac{1}{2}$ meter deep)
- " $1\frac{1}{2}$ " broad) No further
- (b) Wind tunnel - " 5 or 6 meters long) details
- ") available.
- (c) Photographic apparatus)

26. [Redacted] the tunnel was compressor operated, and stated that the figure of 3.5 Mach was frequently quoted in connection with this tunnel.

27. From time to time small conical shaped models were received from PODLIPKI for test in the water channel and wind tunnel. The length of these objects varied between 3 to 6 inches. Some models were also made at OSTASCHKOV. (Note: In connection with the shape of the models, besides using the word 'conical' (Kegel), informant said they were similar to 'church steeples'.)

28. The models were not round but were wedge shaped.

29. During the tests photographs were made, [Redacted] 25X1
[Redacted] the purpose of the tests was to photograph the air and water current flow past the models. She mentioned that the terms "streamline flow", "turbulence" and Prandtl's number or coefficient were used frequently in connection with these tests.

30. [Redacted] an aircraft frequently circled the island, and that it was common knowledge that the aircraft had some connection with the work of the H.F. department.

31. A vertical rod type aerial was seen situated near a part of the island's perimeter. [Redacted] 25X1

SECRET

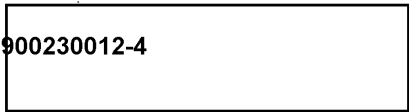

~~SECRET~~

NOTE: APART FROM ITEMS SHOWN, PLUS A ROU TYPE AERIAL SOMEWHERE ON THE ISLAND, THE ISLAND SHOULD BE CONSIDERED TO BE DENSELY WOODED.

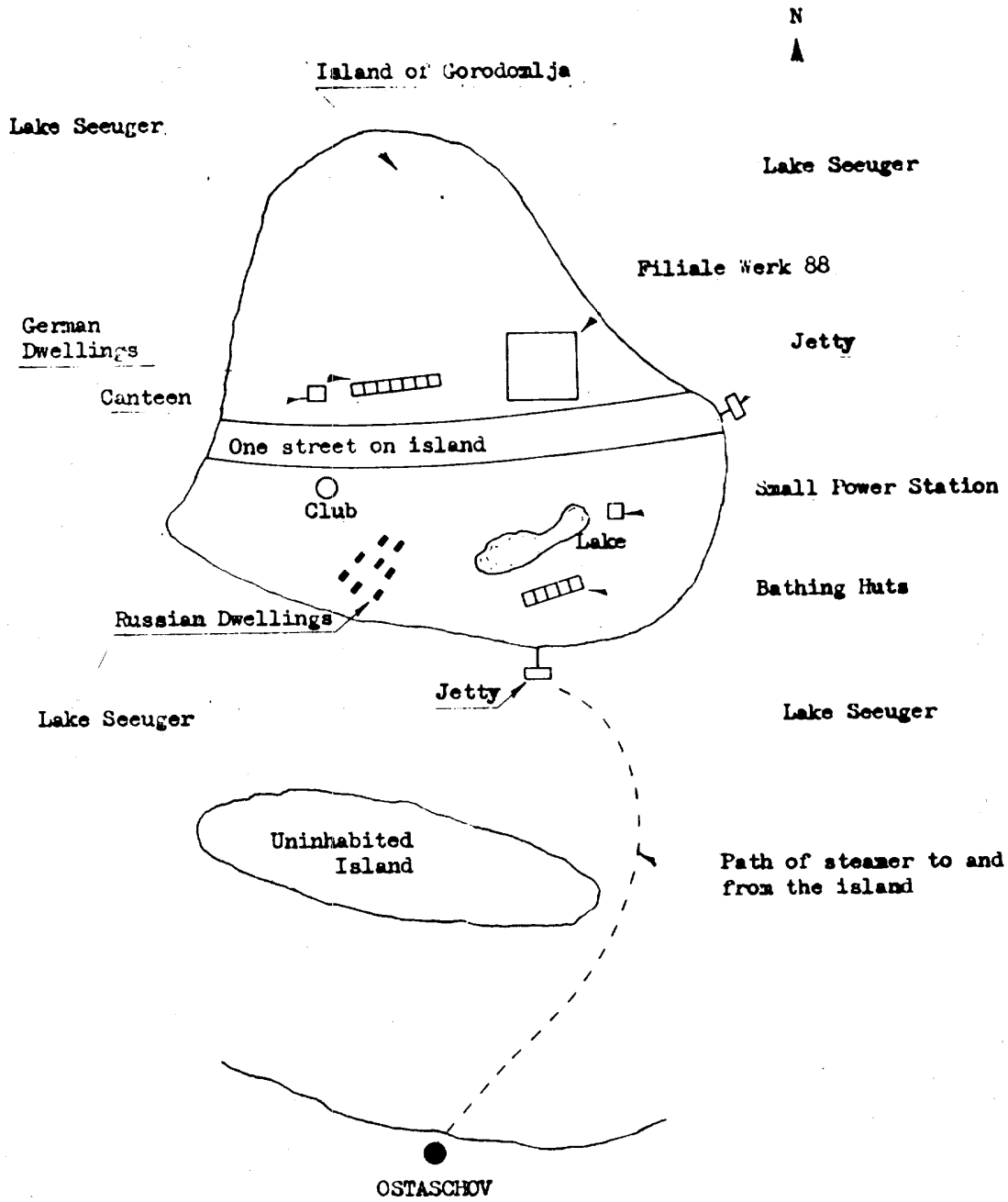

ROUGH SKETCH SHOWING LAKE SEEUGER, ISLAND OF GORODOMLJA AND OSTASCHOV. (Not to scale: not orientated)

7574018UR