

TELETYPE
FEB 1952

CENTRAL INTELLIGENCE AGENCY

CLASSIFICATION

SECRET

SECURITY INFORMATION

25X1

INFORMATION REPORT

REPORT

CD NO.

COUNTRY USSR (Caspian)

DATE DISTR. 22 August 1952

SUBJECT Soviet Submarines in the Caspian
25X1

NO. OF PAGES 2

DATE OF INFO.

NO. OF ENCLS. 3
(LISTED BELOW)

PLACE ACQUIRED

25X1

SUPPLEMENT TO REPORT NO.

[Redacted]

THIS DOCUMENT CONTAINS INFORMATION AFFECTING THE NATIONAL DEFENSE OF THE UNITED STATES, WITHIN THE MEANING OF TITLE 18, SECTIONS 793 AND 794, OF THE U.S. CODE, AS AMENDED. ITS TRANSMISSION OR REVELATION OF ITS CONTENTS TO OR RECEIPT BY AN UNAUTHORIZED PERSON IS PROHIBITED BY LAW. THE REPRODUCTION OF THIS FORM IS PROHIBITED.

[Redacted]

THIS IS UNEVALUATED INFORMATION

[Redacted]

25X1 1. In the Fall of 1950, probably in September, three submarines loaded on floating docks
25X1 came down the Volga and were towed to the Shipyard i/n Karl Marks at Astrakhan. [Redacted]

25X1 [Redacted]
25X1 [Redacted] submarines for
25X1 the first time at the above shipyard in October 1950. They were still in the float-
25X1 ing docks, painted green, in which they had arrived.

25X1 2. In each dock there was a submarine, covered by canvas. The submarines were painted
25X1 with red lead and had no deck construction, no masts, no weapons, only a conning
25X1 tower. The submarine's hull was about 80 m long and eight m wide. The submarine
25X1 docks, made of steel, were 12 m high, 16 m wide, including the sides, but were not
25X1 long enough to accomodate the whole submarine. One end of the hull - [Redacted]

25X1 [Redacted] it was the stern in all three cases - protruded about 10 m beyond the
25X1 dock. /See Encl A./ [Redacted] the three
25X1 submarines were of the same series and looked identical.

25X1 3. [Redacted]
[Redacted] The conning tower had an irregular shape, about 7 to 12 m in diameter,
and was 3 to 3.5 m high. /See Encl B/ It was most probably made of cast steel [Redacted]
[Redacted] there were no rivets connecting its parts. On the back of the
tower there were several openings,

CLASSIFICATION

SECRET

STATE	<input checked="" type="checkbox"/>	NAVY	<input checked="" type="checkbox"/>	NSRB		DISTRIBUTION									
ARMY	<input checked="" type="checkbox"/>	AIR	<input checked="" type="checkbox"/>	FBI	<input checked="" type="checkbox"/>										

SECRET/SECURITY INFORMATION

-2-

15-20 cm in diameter. There may have been some openings on the front part too, 25X1
 the bow of all three submarines was considerably higher than the stern. the bow was six m high and the stern three m. there were no wooden parts or any constructions whatever on these submarines. 25X1

4. The three submarines were left in their floating docks at the Karl Marks shipyard during the Winter 1950-51 and no work of any kind was done on them during this period. 25X1

5. Early in the Spring of 1951, about 25-30 March, ReydTanker received an order through the Naval Kommandatura in Astrakhan that the submarines were to be towed to Baku (by ReydTanker) and therefore were to be transferred to the Ship Repair Yard imeni Tenth Anniversary of the October Revolution which belonged to ReydTanker. This was apparently being done to give the tugboat captains time to familiarize themselves with the floating docks which they were to tow to Baku. After four days in this shipyard, the submarines were towed by three 900 hp propeller-type tugs to Baku. The docks were towed with the open side forward.

6. In Baku, the docks with the submarines were taken to Pier No 26 and attached to it /See Encl (C)7. They were received in Baku by naval personnel from the destroyer "Sekstan"; after the documents were signed, the tugboats returned to Astrakhan. 25X1

7. The chief engineer of ReydTanker, Smirnov (fnu), these floating submarine docks were a special kind which could be used as construction docks, launchers, and transport docks. 25X1

these submarines and docks had arrived from Gorkiy and that the submarines and docks had been manufactured in Zavod imeni Zhdanov (formerly Krasnoye Sernovo). Since Smirnov had been in charge of all the negotiations concerning the move from Astrakhan to Baku, it had been necessary for him to get in touch with the plant where the submarines were built. 25X1

8.

Attachments: 1 - Sketch of Submarine Dock
 2 - Sketch of Submarine
 3 - Location of Submarines at Baku

SECRET

ENCLOSURE (A)

SECRET/SECURITY INFORMATION

25X1

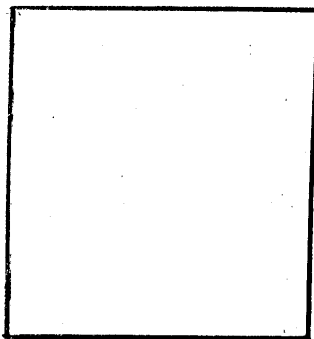
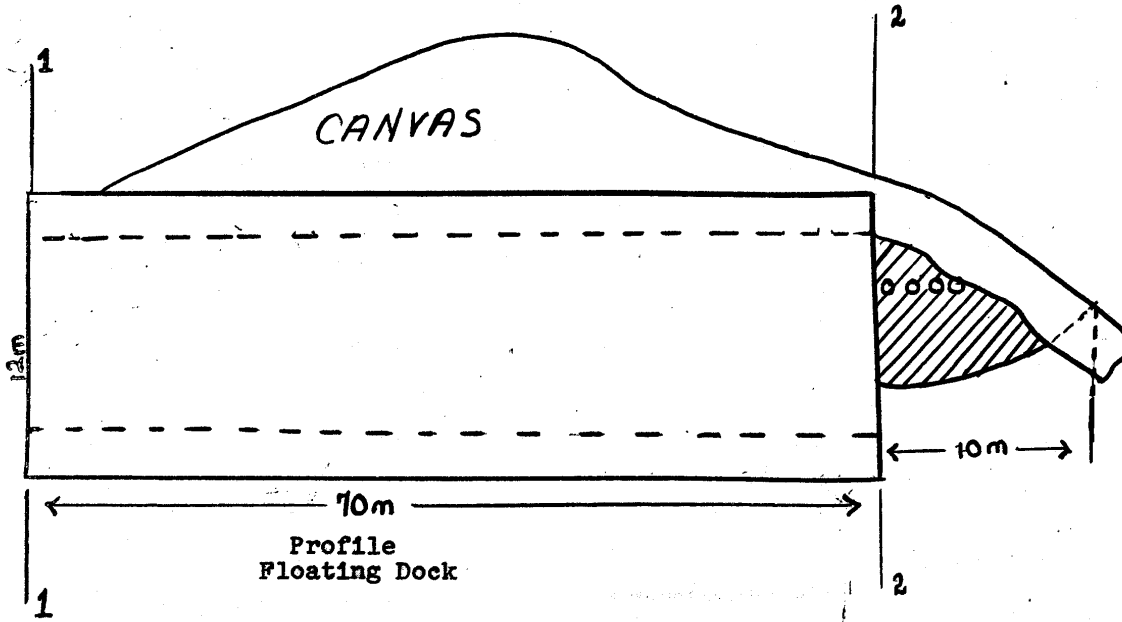

Rear View

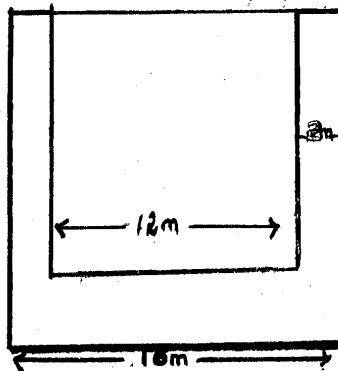

Front View

Cross Sections

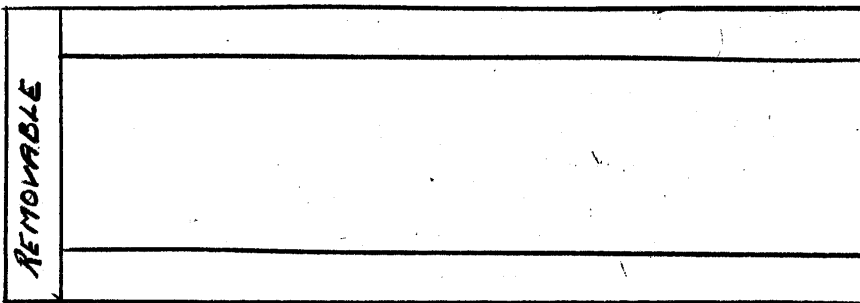

Plan

Submarine Dock
Memory Sketch

SECRET

ENCLOSURE (B)

SECRET/SECURITY INFORMATION

25X1

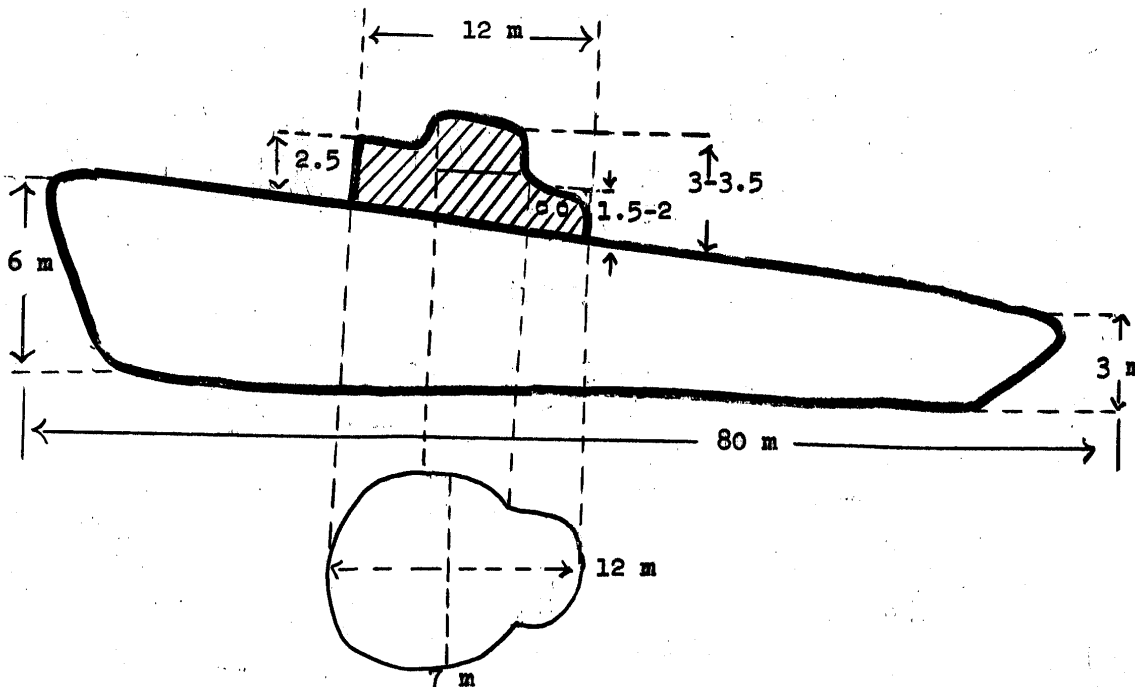

Submarine
Memory Sketch

SECRET

ENCLOSURE (C)

SECRET/SECURITY INFORMATION

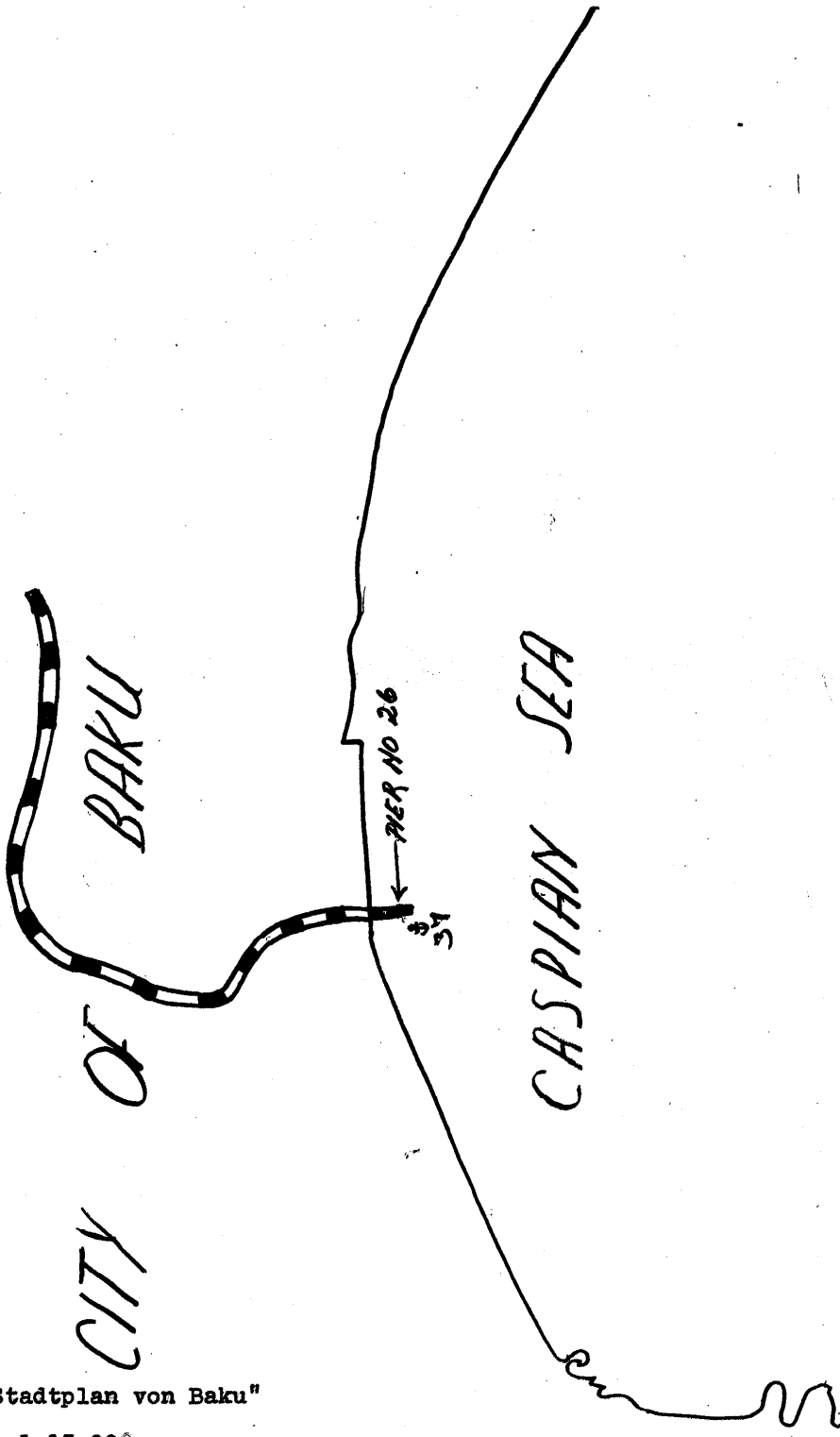

Overlay "Stadtplan von Baku"

Scale appr 1:15,000

SECRET