

INTELOFAX 13

000

CLASSIFICATION ~~SECRET~~ CONTROL-US OFFICIALS ONLY
SECURITY INFORMATION
CENTRAL INTELLIGENCE AGENCY

25X1

INFORMATION REPORT

CD NO.

COUNTRY USSR (Moscow)
SUBJECT Aircraft Observed Over Moscow

DATE DISTR. 11 Feb. 1952

NO. OF PAGES 3

NO. OF ENCLS. 4
(LISTED BELOW)

SUPPLEMENT TO REPORT NO. 25X1

25X1

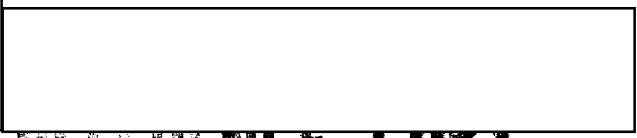
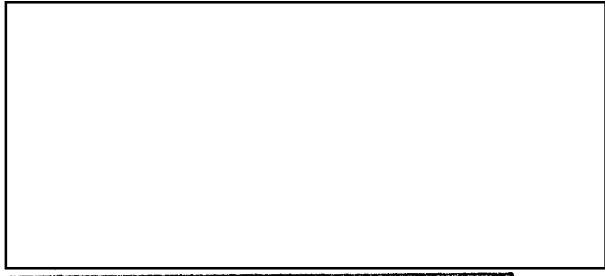

THIS DOCUMENT CONTAINS INFORMATION AFFECTING THE NATIONAL DEFENSE OF THE UNITED STATES, WITHIN THE MEANING OF TITLE 18, SECTIONS 793 AND 794, OF THE U. S. CODE, AS AMENDED. ITS TRANSMISSION OR REVELATION OF ITS CONTENTS TO OR RECEIPT BY AN UNAUTHORIZED PERSON IS PROHIBITED BY LAW. THE REPRODUCTION OF THIS FORM IS PROHIBITED.

CONFERENCE COPY
THIS IS UNEVALUATED INFORMATION
DO NOT CIRCULATE



25X1

1. Double-fuselage plane fitted with a ring (Annex 1). Individual planes of this type were seen over the town. The same type was later seen several times near Riga. (1)

2. Descriptive data:

Two in-line engines over the wings, rear part of engines projecting far beyond trailing edge of wings; through wings without sweep-back or dihedral. Double rudder assembly set at rear of fuselage, shape not remembered; through and straight elevator assembly set between the two fuselages. No landing gear was seen. The two fuselages were set above the wings, their cross section was smaller than that of the engines. No cockpit was seen. Details on the mounting of the ring and the size of the craft were not available. The craft appeared very slow. (1)

3. Aircraft seemingly flying rearward:

On 10 different days an individual blue biplane and a red shoulder-plane were seen at an altitude of from 200 to 300 meters. [redacted] the planes had their tail assemblies set at the front.

25X1

Document No. 008

No Change in Class.

Declassified

Class. Changed To: TS S **(C)**

Auth.: HR 70-2

Date: SEP 11 1978

CLASSIFICATION ~~SECRET~~ CONTROL-US OFFICIALS ONLY

STATE #	NAVY	<input checked="" type="checkbox"/>	NSRB											
ARMY #	AIR #	<input checked="" type="checkbox"/>	FBI											

~~CONFIDENTIAL~~ CONTROL-US OFFICIALS ONLY

CENTRAL INTELLIGENCE AGENCY [redacted]

25X1

Their speed was that of the standard Soviet bi-planes and their engines produced the sound of the craft known as "sewing machines". Both planes had a fixed landing gear. [redacted]

25X1

[redacted] the propeller at the engine was standing still, although the noise of the flying craft was heard. No other propeller was seen. (2)

4. Four four-engine bombers (Annex 2), flying in single file at an altitude of about 800 meters. The bombers were escorted by three or four conventional fighters.
5. About 27 twin-engine aircraft (Annex 3), flying in flights one after the other at an altitude of about 600 meters. The formation was escorted by six to eight conventional fighters. (3)
6. Forty to 50 jet planes flying in flights one after the other (Annex 4).
7. About 20 twin-engine aircraft towing one cargo glider each and flying in flights one after another (Annex 3). No details available on cargo glider. (3)
8. During the entire time jet planes were flying individually and in flights at various altitudes. The jet planes made dives, steep climbs and acrobatics, also in flight formation. [redacted] all the jet planes were of a uniform type. No details available (Annex 4).
9. Descriptive data:
 - a. Four-engine bomber (Annex 2):

25X1

Four radial engines mounted in slim wings of large span, engines projecting rather far beyond leading edge of wings. Single rudder assembly. Blunt rear of fuselage. The very slim fuselage had a circular cross section. No glazing of nose noted, the nose was painted darker than the rest of the plane. Tortoise-shaped cockpit set on top of fuselage with struts. A rod about 1 1/2 meters long, believed to be a flexible gun, projected from the nose. A hemispherical attachment, painted darker than the fuselage, was distinctly seen under the fuselage. A rod of the same size as that observed at the nose and also believed to be a flexible gun projected to the fore. Another gun station with weapon pointing to the rear was on the fuselage.

~~CONFIDENTIAL~~ CONTROL-US OFFICIALS ONLY

~~CONFIDENTIAL~~ CONTROL-US OFFICIALS ONLY

CENTRAL INTELLIGENCE AGENCY [REDACTED]

25X1

b. Twin-engine aircraft (Annex 3):

Two radial engines, low-wing monoplane without sweep-back or dihedral, leading edge of wings straight, trailing edge tapering, rounded wing tips. The fuselage projected a little over the tail assembly. Single-strut main landing gear with duals retracting rearward into the fuselage, faired with two covers attached to the fuselage. The tail wheel was not retracted during the flight. A short rod, possibly a flexible weapon, projected downward from the nose. Under the nose was a black circular body attached to a curved leg; [REDACTED]

c. Jet planes (Annex 4):

No details available on the power plant; only a nozzle was seen at the rear of the fuselage. The tail assembly, attached to thin tail booms, was mounted high above the rear of the fuselage, swept-back elevator assembly, angular tips, no dihedral. Weapons or other attachments were not seen.

[REDACTED] Comment:

- fitted
- (1) The craft is a mine-locating plane/with a magnetic ring. Such aircraft were previously observed near Khimki and Stakhanovo. Near Khimki both Ju-52 (Jausi) and twin-engine planes were seen. In Stakhanovo Li-2 or IL-12 planes fitted with this magnetic ring were reportedly seen. If the observation concerning the double fuselage should be correct, type 23 may be assumed to be put to a new use.
 - (2) The shoulder plane presumably is the Mig Utka fitted with the M-11 engine. A biplane of this type is not known.
 - (3) The ^{details} duals of the main landing gear and the nose wheel of the twin-engine plane shown in Annex 3 indicate the IL-12 which was also used as a towing craft on the Moscow Air Show.

- 4 annexes, sketches on ditto:
1. Double-Fuselage Aircraft fitted with Ring Seen over Moscow
 2. Four-Engine Bomber Seen over Moscow.
 3. Twin-Engine Transport Aircraft Seen over Moscow.
 4. Jet Plane Seen over Moscow.

~~CONFIDENTIAL~~ CONTROL-US OFFICIALS ONLY

Double-Fuselage Aircraft Fitted with Ring Seen over Moscow

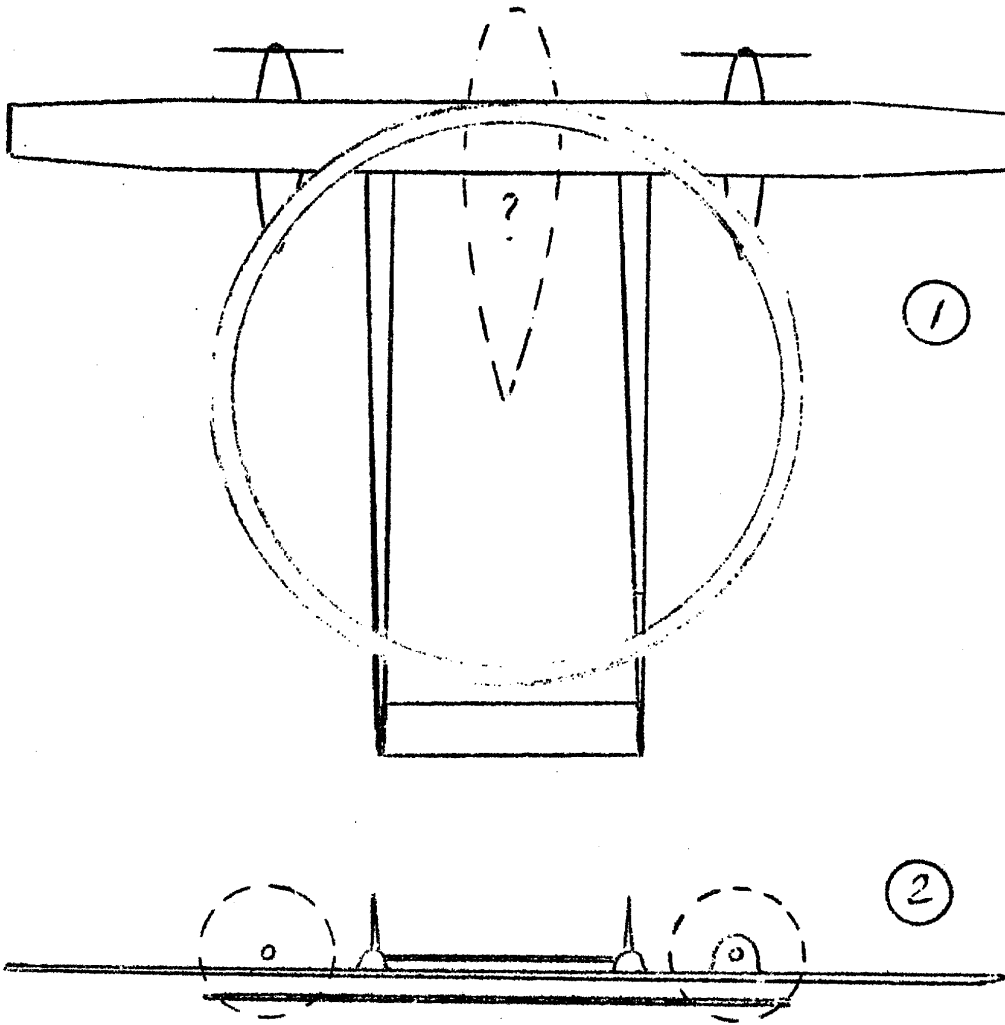

~~CONFIDENTIAL~~ CONTROL-US OFFICIALS ONLY

Four-Engine Bomber Seen over Moscow

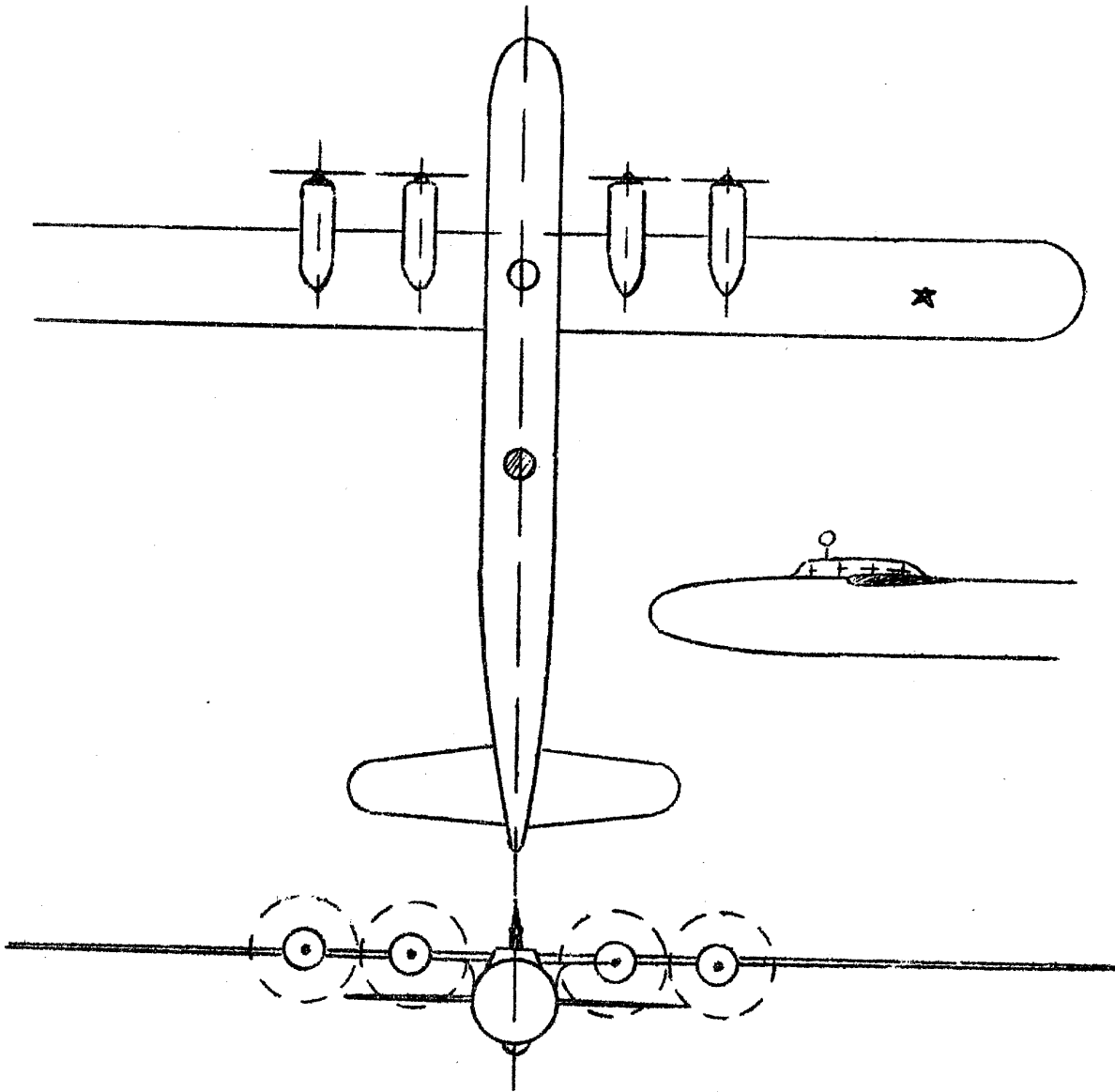
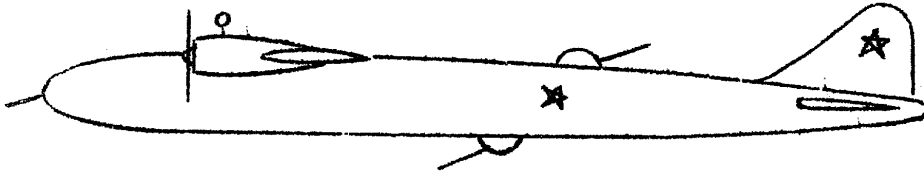

~~CONFIDENTIAL~~ CONTROL-US OFFICIALS ONLY

Twin-Engine Transport Aircraft Seen over Moscow

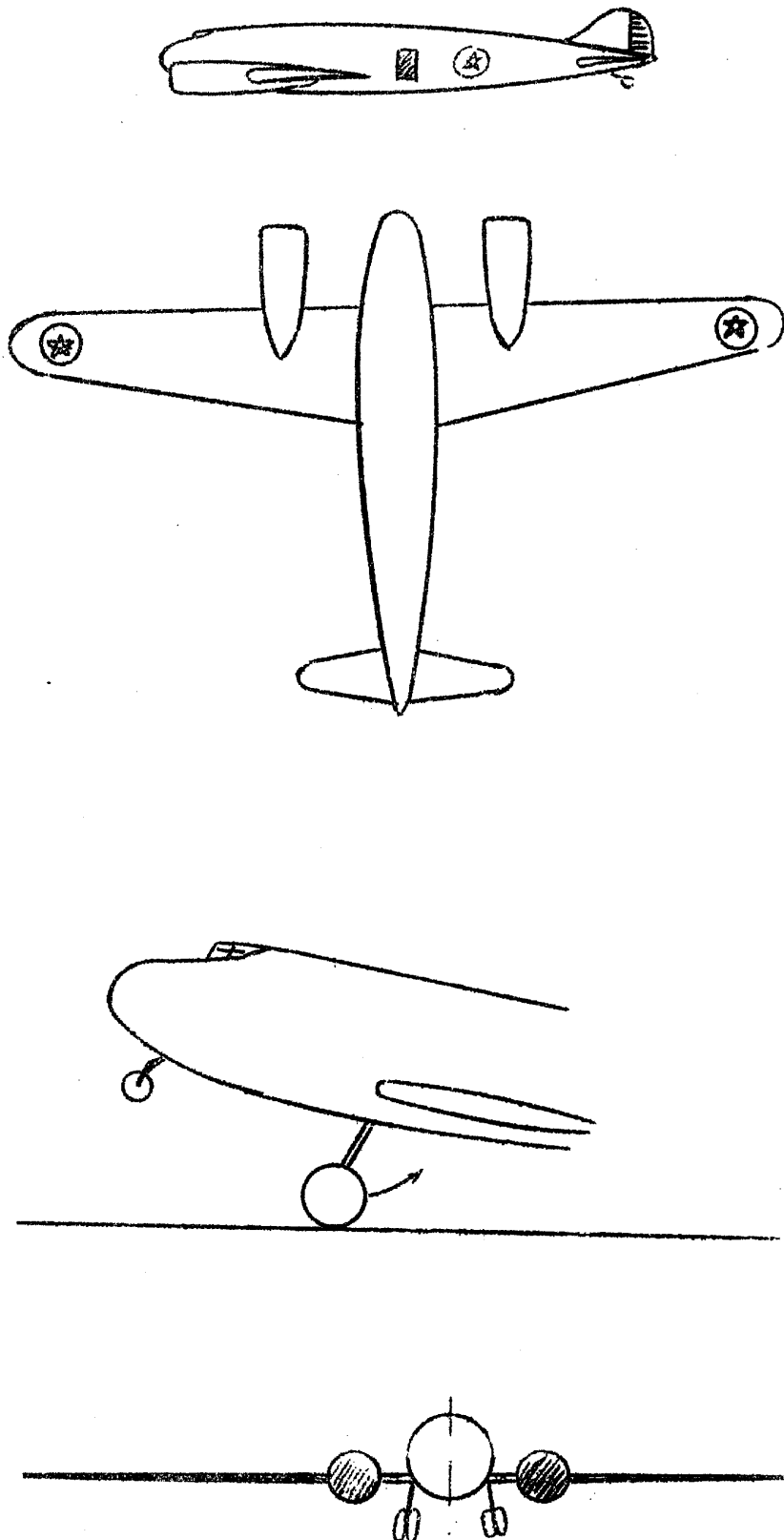

Jet Plane Seen over Moscow

