

CONFIDENTIAL

25X1A

Handwritten: *11/130* and *OCT 8*

CLASSIFICATION

COUNTRY Germany (Soviet zone)

REPORT NO. [REDACTED]

TOPIC Laerz and Rechlin Airfields

25X1X

PAGES 2 ENCLOSURES (NO. & TYPE) 1 - One sketch on ditto

REMARKS

Stamp: **REFERENCE ONLY**
DO NOT CIRCULATE

25X1X

1. On 1 February 1951, three railroad tank cars were observed on the spur track of the Laerz (N 54/U 33) airfield. Thirty-four MIG-15s were counted on the western and southwestern edges of the field. Three of the planes, which were not covered with tarpaulins, were standing near the runway. (1) On the western edge of the field were two jet planes with straight wings, straight rudder assemblies, nose wheel, air exhaust under the fuselage in line with the trailing edges of wings, and a noticeably long cockpit, extending about one third of the entire length of the fuselage. (2) Two low-wing monoplanes with radial engines were also parked on the southern edge of the field. One of the jet fighters with swept-back wings seemed to be a two-seater since its cockpit extended rather far to the rear. (3) There was intensive flying in a partly cloudy sky. Visibility was good. The planes assembled in the air in formations of three, seven, and ten aircraft. Their flying time lasted from 20 to 25 minutes. The field was more strictly guarded than before.

2. On 6 February, a new radar set was seen at Rechlin (N 54/U 33) airfield, at a site at which a radar set was previously located. A rotatable mast, about 3 to 3½ meters high, was fitted on the roof of radio truck [REDACTED]. On top of the mast was a dipole carrier, about 3 meters long, with seven dipoles, each from 60 to 70 cm long. Two leads-ins connected one of the dipoles with the base of the mast. The set was in operation during flying activity. The rear of the radio truck pointed to the southeast. After reaching a neutral position, the entire mast turned about 45 degrees so that it pointed to the east and then made regular movements of 180 degrees to the west and back again. Each movement of 180 degrees lasted about 2 to 2½ minutes. (4)

25X1B

25X1X

25X1X

CONFIDENTIAL

CLASSIFICATION

Document No.	08
No Change in Class.	<input type="checkbox"/>
Declassified	<input type="checkbox"/>
Class. Changed To:	TS 8 0
Auth:	HR 70-2
Date:	2/12/51
By:	02-9

CONFIDENTIAL

SECRET/CONTROL/US OFFICIALS ONLY

2

25X1A



25X1B

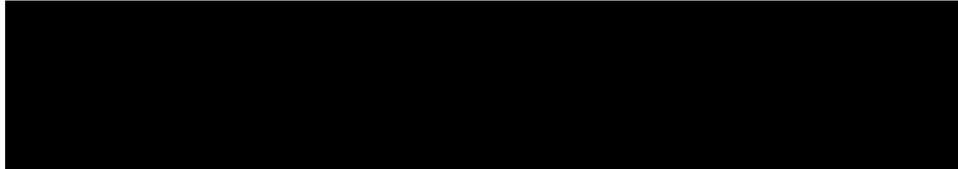

25X1A



Comments.

25X1A

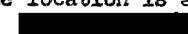
- (1) The same occupation was previously reported by the same source.  Two fighter regiments and one fighter division headquarters are believed to be stationed in Laerz.
- (2) Type 16 jet aircraft. The cockpit is rather long because the plane is a two-seater and is used as a trainer.
- (3) To date, there have been no indications that a two-seater version of the MIG 15 exists. It is possible that the cabin roof of a MIG-15 was slid to the rear, giving the impression of a very long cockpit.
- (4) Same source reported previously that the Dumbo type radar set was removed from Rechlin airfield. See MGL-11735. The radar set which was recently erected at the same location is a RUS-2 type. Its location was reported previously,  For 25X1A
sketch of radio truck with mast, see Annex.

25X1B



1 Annex: One sketch on ditto.

CONFIDENTIAL

SECRET/CONTROL/US OFFICIALS ONLY

~~SECRET/CONTROL/US OFFICIALS ONLY~~
CONFIDENTIAL

Radio Truck at Rechlin Airfield

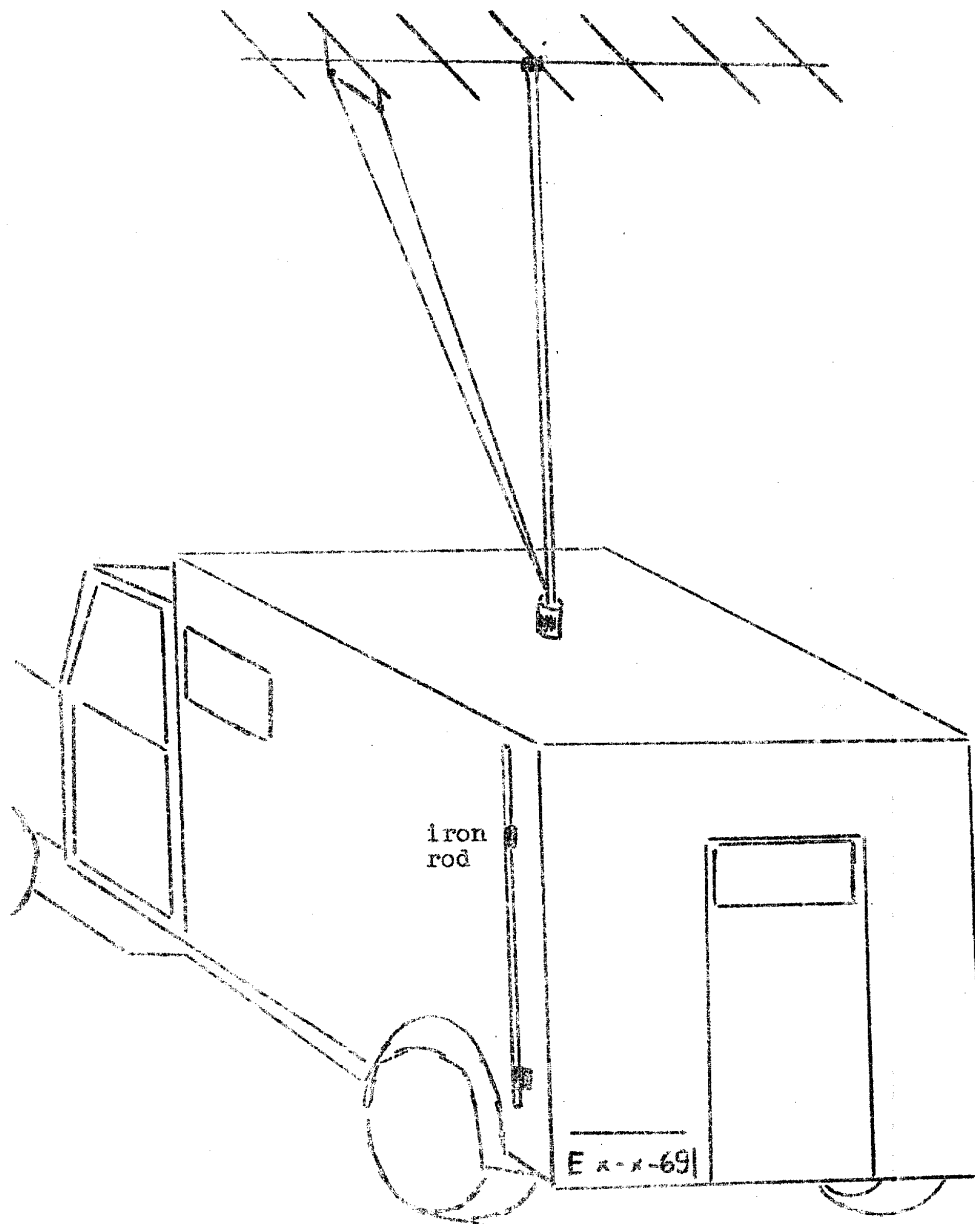

CONFIDENTIAL

~~SECRET/CONTROL/US OFFICIALS ONLY~~