

Page Denied

Next 5 Page(s) In Document Denied

Sept. 2, 1969

H. SCHMIDT

3,464,770

COMBINED SIGHTING MECHANISM AND LASER RANGE FINDER

Filed Oct. 21, 1965

2 Sheets-Sheet 1

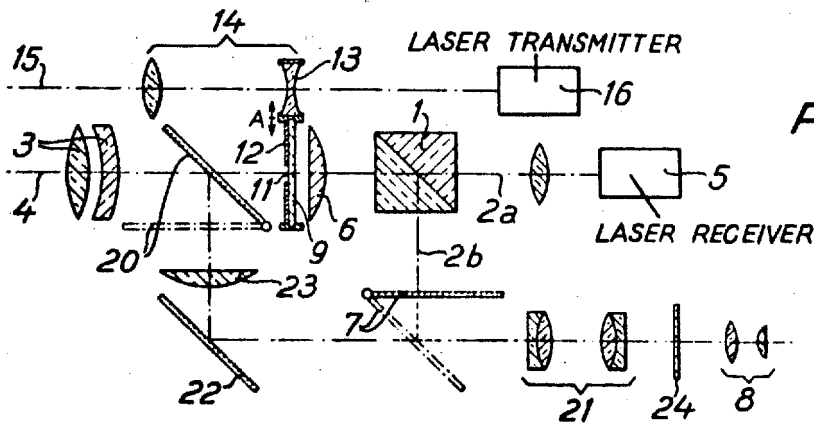
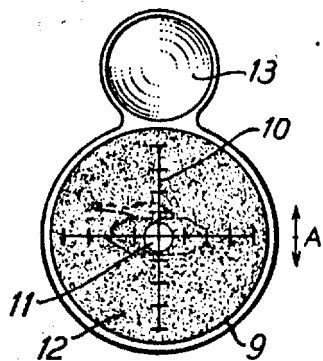
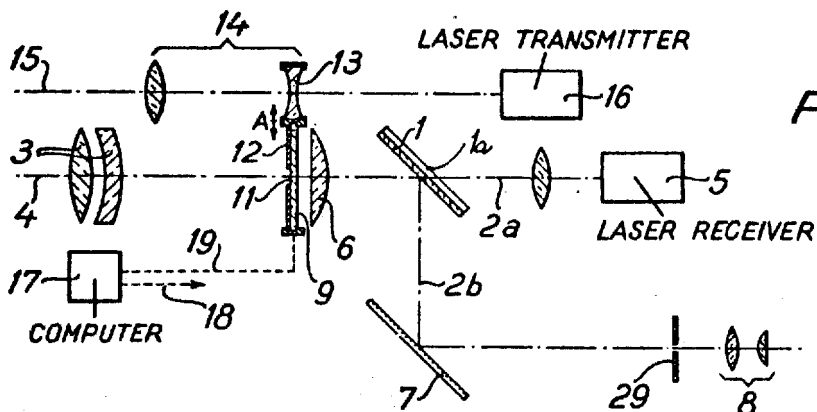

INVENTOR

Horst Schmidt

BY *Spencer & Kaye*

ATTORNEYS

Sept. 2, 1969

H. SCHMIDT

3,464,770

COMBINED SIGHTING MECHANISM AND LASER RANGE FINDER

Filed Oct. 21, 1965

2 Sheets-Sheet 2

Fig. 4

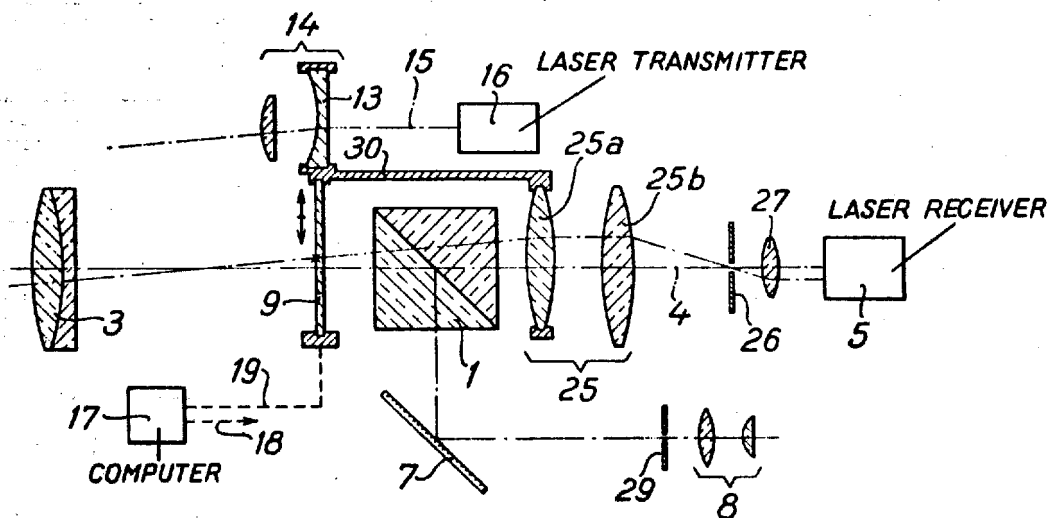

INVENTOR
Horst Schmidt

BY *Spencer E. Kaye*

ATTORNEYS

United States Patent Office

3,464,770

Patented Sept. 2, 1969

1

2

3,464,770

COMBINED SIGHTING MECHANISM AND LASER RANGE FINDER

Horst Schmidt, Nauborn, Kreis, Wetzlar, Germany, assignor to Ernst Leitz GmbH, Optische Werke, Wetzlar, Germany

Filed Oct. 21, 1965, Ser. No. 499,346

Claims priority, application Germany, Nov. 7, 1964,

L 49,230; Sept. 3, 1965, L 51,552

Int. Cl. G01c 3/08; F41g 3/06; G02b 23/10

U.S. Cl. 356-4 9 Claims

ABSTRACT OF THE DISCLOSURE

Arrangement combining a laser range finder, including transmitter and receiver, with a sighting mechanism, including an ocular, for determining the distance of a target and for adjusting the angle of elevation required to fire a projectile at the target. The laser range finder and the sighting mechanism have partially coextensive beam paths. A divider mirror in the beam path of the sighting mechanism directs received rays to the laser receiver and sighting mechanism ocular. A reticle plate arranged in front of the mirror is connected to an element of an optical system provided in front of the laser transmitter. The reticle plate and such element are displaceable transversely to the optical axis of such optical system. Means provided in the beam path to the laser receiver block the rays reflected from the target to which the laser receiver is sensitive, except for rays, which correspond to the transmitted beam in divergence and direction and which are within the visible portion of the spectrum; the former being passed to the laser receiver and the latter to the ocular of the sighting mechanism via the divider mirror. Means are also coupled between the laser receiver and the reticle plate for displacing the reticle plate and such element in response to signals from the laser receiver. By this arrangement, adjustments can be made in the elevation angle required for a projectile to reach the target.

The present invention relates to an arrangement wherein a visual sighting mechanism is coupled with a laser range finder and wherein the arrangement is provided with a device which adjusts for the angle of elevation required, e.g. for a weapon associated with the arrangement to fire a projectile at a target.

A device of this type is known wherein the angle of elevation for a weapon associated with the device is determined by adjusting a rotating pair of prisms provided in the beam path of both the sighting mechanism and the laser transmitter. Since the rotating prisms must receive each beam path in contradistinction to a single beam path, the diameter of the optical systems for the pair of rotating prisms and also for the associated optical components positioned in front thereof must necessarily be correspondingly larger. It has therefore been suggested that this disadvantage may be overcome by directing the beam of rays of the laser transmitter within the region of the beam path of the sighting mechanism. However, this is impossible without limiting the field of a portion of the beam required for the visual sighting device. Aside therefrom, the use of a rotating prism pair represents a substantial increase in the cost of the device because the prisms, of necessity, must be made of a complicated construction in order that the prisms have good optical and mechanical properties.

Another disadvantage of the prior arrangements is that when the mechanism is incorporated into armored vehi-

nection between the adjusting device in the interior of the vehicle and the rotating prisms located on the outside of the vehicle.

Additionally, there is a further disadvantage in that rotating prisms generally produce astigmatic distortions and secondary chromatic aberrations. Furthermore, the components can not be cemented together because of the intense laser radiation and the resulting glass-air areas cause disturbing reflections.

It is an object of the present invention to provide an arrangement of a sighting mechanism coupled with a laser range finder which is of simple construction and economical to produce.

It is another object of the present invention to provide a combined sighting mechanism and laser range finder having a common optical system for a portion of the beam paths.

It is a further object to provide a combined sighting mechanism and laser range finder having an optical system which is relatively free of distortions.

In accordance with the present invention, the aforementioned disadvantages of the prior arrangements are overcome by providing in front of a chromatic divider mirror mounted in a conventional manner in the beam path of a sighting mechanism, a reticle plate, and connecting the plate with an element of the optical system arranged in front of a laser transmitter, with the plate being mounted for displacement transverse to the optical axis. There is further provided in the beam path of a laser receiver, optical means which block the rays to which the laser receiver is sensitive, except for the rays which are reflected from the target and correspond to the transmitted beam in divergence and direction and for the rays within the visible portion of the spectrum which are fed to the ocular of the sighting mechanism via the divider mirror.

According to a feature of the invention, the blocking may be accomplished by providing a coating on the reticle plate, except for a small central surface portion, for blocking the rays lying beyond the visible portion of the spectrum to which the laser receiver is sensitive. Thus the coating forms a diaphragm for limiting the beam of rays used for measuring and which is united with the reticle plate.

Although the arrangement including a coating as a diaphragm for blocking the rays is more economical than prior arrangements, the coating increases the expense of the arrangement. Therefore, according to another feature of the invention, the diaphragm is separated from the reticle plate and is mounted in a plane that is optically related to the plane of the reticle plate. There is further provided means which ensure that the received rays that are used for measuring and which are parallel to the transmitted rays always enter through the center of the diaphragm regardless of the position of the reticle plate. The diaphragm may be adjusted to correspond to the different positions of the reticle plate by means of a complicated gear arrangement. However, the present invention provides a simplified arrangement wherein a two-member optical system having a parallel beam path between the two-members is arranged in front of the fixed diaphragm of the laser receiver. The reticle plate image is then produced in the diaphragm plane, and the member of the system which is adjacent the reticle plate is connected to the reticle plate and is displaceable with the plate in a plane transverse to the optical axis. The beam divider is suitably arranged between the reticle plate and the member of the two-member system which is arranged in front

3,464,770

3

According to a further feature of the present invention, there is provided a pancratic or zoom lens telescopic sight as the sighting mechanism, wherein the sight may be used with the laser range finder or as an auxiliary system in place of the laser range finder.

Additional objects and advantages of the present invention will become apparent upon consideration of the following description when taken in conjunction with the accompanying drawings in which:

FIGURE 1 is a schematic view of the combined sighting and laser beam measuring device having the reticle plate coupled with the device for blocking rays.

FIGURE 2 is a front view of the reticle plate of FIGURE 1 with a target indicated thereon in dash-dot lines.

FIGURE 3 is a schematic view of another embodiment of the present invention having a pancratic telescope sight and a deflection device.

FIGURE 4 is a further embodiment of a combined sighting and laser beam measuring device according to the present invention having a reticle plate and a diaphragm that are arranged in different planes.

Referring now to the drawings, there is shown in FIGURE 1 a reticle plate 9 arranged in front of a chromatic divider or semi-reflecting mirror 1 which directs a portion 2a of the rays 4 coming from an objective 3 of the sighting mechanism to a laser receiver 5 and reflects a portion 2b via a field lens 6 and a mirror 7 to an ocular 8 with the field of view plane 29 being arranged in the ocular image plane. As can be seen, a plane parallel plate 1q supports the mirror 1. As shown in FIGURE 2, the reticle plate 9 which is fully permeable for the visible portion of the spectrum carries the line configuration 10 and is provided, outside of the central portion 11, with a coating 12 which is impermeable to laser rays, the size of the central portion 11 being determined by the scattering angle of the laser transmitter and by the focal length of the optical system of the sighting mechanism provided in front of the reticle plate. The coating may be of any suitable type such as a reflective coating effective only for laser rays. The reticle plate is connected with the negative optical member 13 of a two optical member Galilean system 14 and is displaceable with the member 13 in the direction of arrow A transverse to the optical axis of the two member optical system.

The Galilean system has an axis 15 which extends in parallel with the center line of the objectives 3 and is arranged in front of a laser transmitter 16, whereby the negative member 13 which is connected to the reticle plate causes a deflection of the transmitted laser rays. The displacement of the negative element has the same optical effect as the displacement of the reticle plate. The displacement can be done in two coordinates at right angles to the optical axis of the laser transmitter and at right angles to the optical axis of the optical system provided in front of the divider mirror, respectively, i.e., in a plane transverse to the optical axis. A computer 17 is connected via a cable 18, with the laser beam measuring device and transmits its commands to the reticle plate 9 via the connection 19. The mechanical means for adjusting the sighting mechanism are not illustrated in the drawing.

The mode of operation of the arrangement shown in FIGURE 1 is essentially as follows: At first, the sighting procedure is carried out in the conventional manner through use of the visual sighting mechanism with the entire system including a weapon coupled thereto, being set on the target with respect to height and direction. Thereafter, the range finding process is carried out by means of the laser beam device. In this process, the rays 15 emitted by the laser transmitter 16 are received by the objective 3 after reflection at the target and pass through the central aperture 11 of the reticle plate 9 to the divider mirror 1 and to the receiver 5. The sighting mechanism is provided with conventional protective devices which are actuated during the laser range finding. The divider mirror

4

shown in FIGURE 3, a prismatic cube. The reflective coating 12 prevents undesired rays from passing through the reticle plate for these would otherwise impair the measuring result.

The laser beam range finding process is similar to a radar distance measuring process in that the time interval between the emission and reception of the transmitted beam is an indication of the distance of the target. The distance information is then fed to the computer 17, together with other values such as wind speed and direction, target speed, etc. The computer processes this data and determines the elevation and lead angle for the target and transmits the result to the plate 9 via the connection 19. The reticle plate 9 and the lens 13 are then shifted in accordance with the computer calculation to compensate for the elevation angle necessary for a projectile to reach the target. However, the shifting of the plate and the lens 13 results in the target no longer being centered in the cross-hairs 10 of the plate 9 since the line of sight is no longer directed at the target and therefore the entire sighting arrangement and the weapon coupled thereto are shifted to again center the target. The movement of the weapon and the sighting arrangement thereby provide the required elevation angle necessary for a projectile to reach the target. The laser beam range finding process may then be repeated to check the target range without having to return the entire arrangement to a basic setting. However, any further changes causing a further shifting of the reticle plate will also have to be compensated for by a corresponding movement of the entire apparatus.

In FIGURE 3, which is another embodiment according to the present invention, there is shown a movable mirror 20 provided behind the objective 3; whereby in case of inoperativeness or non-use of the laser device, the received rays are directed to a pancratic or zoom lens range finder 21 combined with the sighting mechanism. For this purpose, a further deflection mirror 22 and an additional field lens 23 are provided in the beam path. Furthermore, the mirror 7 in this embodiment must be collapsible, i.e., capable of being swung out of the axis of the pancratic system. The deflection system also includes a range finding mark 24, arranged in the ocular 8.

In the arrangement of FIGURE 3, the range finding procedure can be carried out by means of the pancratic system 21 in case the laser device is inoperative, or as a supplement to the laser measuring process. However, in order to use the pancratic system for range finding, the mirrors 20 and 7 must be moved into the position shown in solid line in FIGURE 3. This range finding is then accomplished by changing the enlargement scale of the pancratic system until the target configuration on the range finding mark 24 is adjusted to the size of the target so that the mark is rendered congruent with the target. The adjustment path for changing the magnification which is an indication of the range, can then be used to set the elevation angle of the weapon or the movement of the lens system can be transferred to the reticle plate 9 via means which are not illustrated, and the elevation of the weapon carried out as discussed in connection with FIGURE 1.

Thus, the zoom lens system may be used with the laser arrangement as a complementary system, or as an auxiliary system in place of the laser arrangement for the purpose of range finding.

Furthermore, it is also possible to obtain an auxiliary range finding without using a pancratic optic by providing in the ray path of the visual sighting mechanism a conventional range finder comprising two mutually displaceable sections. In this conventional arrangement, as well as in the arrangement using a pancratic system, the range finding mark is positioned in the image plane of an intermediate image producing system included in the auxiliary system. In order that only this measuring mark be visible in the field of vision, it is advantageous to circulate the image plane

5

by means of a mirror arrangement similar to that of FIGURE 3. However, if the range finding marks are advantageously arranged, for example in such a manner that they do not overlap one another, the feature of eliminating the reticle plate by deflection mirrors can be omitted.

In the arrangement shown in FIGURE 4, which is a further embodiment of the present invention, there is provided a further two-member optical system comprising lens 25a and lens 25b, a diaphragm 26 and a lens 27 arranged in front of the laser receiver 5. Reflected rays are directed to the beam divided mirror via the objective 3 arranged in the optical axis 4 of the laser receiver, after passing through the reticle plate 9. The beam divider 1 splits the received rays so that a portion of the rays is fed to the ocular 8 of the sighting device via the deflection mirror 7 and the other portion passes through the beam divider to the laser receiver via the two member system 25, the diaphragm 26 and the lens 27, with diaphragm 26 corresponding to the coating 12 as shown in FIGURE 1 for limiting the beam of rays used for measuring the range.

The reticle plate 9 is arranged in the front focal plane of the lens 25a and the diaphragm 26 in the back focal plane of the lens 25b of the system 25 which is constructed to provide collimated rays between the two lens members, whereby the image of the reticle plate is produced in the diaphragm plane. The lens 25a is fixedly connected with the reticle plate 9 through a connecting member 30 and together with the plate is displaceable in a plane transverse to the optical axis of the system. The negative member 13 of the Galilean system 14, which is arranged in the beam path 15 of the laser transmitter 16, is also coupled with the reticle plate and is displaceable therewith. The reticle plate 9 is controlled via the cable 19 from the computer 17 which evaluates the measuring results fed to it from the laser beam range finder via cable 18.

The mode of operation of the device shown in FIGURE 4 is as follows: As in the operation of the arrangement of FIGURE 1, the range finding process is first performed in a conventional manner by using the sighting device, whereby the entire arrangement including the coupled weapons is set on the target in height and direction. The target line of the telescope, the transmitted laser beam, the received laser beam and the bore axis of the weapons are then arranged parallel to each other. The measuring of the range is then performed by means of the laser range finding device. The rays 15 transmitted by the transmitter 16 are in a conventional way received by the objective 3 after having been reflected by the target and then reach the chromatic divided mirror 1 after having entered through the reticle plate 9. The divided mirror separate the visible portion of the rays and directs that portion to the ocular 8 of the sighting device with the laser beams being passed to receiver 5 via the system 25 and the lens 27. The results of the receiver are fed to the computer 17 for calculation of the angle of lead and elevation which is then transferred to the reticle plate 9 by displacing the same.

The displacement of the negative member 13 and the lens 25a with the reticle plate results in the target line of the telescope as well as the transmitted and received laser beam being maintained parallel to each other, but forming as desired, an angle relative to the weapon coupled therewith. The shifting of the reticle plate 9 and the sight line toward the target is then compensated for by counter-steering the entire sighting arrangement and the weapons, thereby providing the elevation angle required for a projectile to reach the target.

The operation of the present embodiment is dependent upon the displacement of the lens 25a with the reticle plate. Due to the afore-described construction of the system 25, it is provided that in any angular position

6

existing between the transmitted beams and the bore axis of the weapons coupled to the sighting arrangement only those received rays that enter parallel to the transmitted rays are directed in the desired way through the center of the diaphragm 26 to the laser receiver 5 for a true determination of the range.

Thus, it is seen from the afore-described embodiments that the present invention provides arrangements including laser beam range finders which directly adjust for the angle of elevation by movement of the reticle plate. These arrangements are economical to produce and are relatively free of distortion since the need for additional optical components of complicated structure is eliminated. As shown, the present invention also provides means for limiting the rays passed to the laser receiver, such as the coating on the reticle plate and the separate diaphragm in a different plane from that of the reticle plate, in order to provide a true measurement of the target range.

It will be understood that the above description of the present invention is susceptible to various modifications, changes, and adaptations.

What is claimed is:

1. A combined sighting mechanism and laser range finder arrangement for determining the distance of a target from the arrangement and for adjusting for the angle of elevation required for a weapon associated with the arrangement to fire a projectile at the target, the arrangement comprising, in combination:

- a laser range finder including a laser transmitter for transmitting laser rays to a target along a beam path and a laser receiver for receiving reflected rays from the target along a beam path;
- a sighting mechanism optical system having a beam path and including an ocular, said beam path of the sighting mechanism optical system and said beam path of the laser receiver being at least partially co-extensive;
- a divider mirror mounted in the beam path of said laser receiver for transmitting received rays from the target to said laser receiver and for reflecting received rays from the target for direction to said ocular of said sighting mechanism optical system;
- a two-member optical system arranged in the beam path of said laser transmitter;
- a reticle plate mounted in front of said divider mirror in the beam path of the laser receiver and the sighting mechanism optical system and coupled to one member of said two-member optical system for displacement in a plane transverse to the optical axis of such two-member optical system, such displacement adjusting the elevation angle required for a projectile to reach the target;

means for passing to said laser receiver that portion of the rays reflected from the target which correspond in direction and divergence to the transmitted rays and to which said laser receiver is responsive, and for passing to said ocular of the sighting mechanism optical system that portion of the rays reflected from the target which fall within the visible spectrum by way of said mirror, and for blocking the other rays to which said laser receiver is responsive; and

means coupled between the laser receiver and the reticle plate and responsive to signals from said laser receiver for displacing the reticle plate and said one member of the two-member optical system in said transverse plane thereby to adjust for the elevation angle required for a projectile to reach the target.

2. An arrangement as defined in claim 1 wherein said reticle plate is fully permeable for the visible portion of the spectrum and said means for passing and for blocking the rays is a coating impermeable to laser rays provided on said reticle plate having a small open portion of a predetermined size at the center of said reticle plate for passing the rays to which the laser receiver is responsive, the

7

size of said open portion being determined by the scattering angle of said laser transmitter and by the focal length of the optical system of said sighting mechanism.

3. An arrangement as defined in claim 2 wherein the coating provided on said reticle plate outside of the central open portion reflects rays to which the laser receiver is responsive.

4. An arrangement as defined in claim 1 wherein said two member optical system is a Galilean system, said member connected with said reticle plate being the negative lens thereof.

5. An arrangement as defined in claim 1 wherein said sighting mechanism is a panratic telescopic sight.

6. An arrangement as defined in claim 5 wherein said panratic telescopic sight is provided with a range finding mark for auxiliary range finding in addition to the laser range finder.

7. An arrangement as defined in claim 6 wherein said panratic telescopic sight includes an image-reproducing system and said range finding mark is provided in the image plane of said system.

8. An arrangement as defined in claim 1 wherein said divider mirror is a chromatic mirror and a plane parallel plate supports said mirror.

9. A combined sighting mechanism and laser range finder arrangement for determining the distance of a target from the arrangement and for adjusting for the angle of elevation required for a weapon associated with the arrangement to fire a projectile at the target, the arrangement comprising, in combination:

a laser range finder including a laser transmitter for transmitting laser rays to a target along a beam path and a laser receiver for receiving reflected rays from the target along a beam path;

a sighting mechanism optical system having a beam path and including an ocular, said beam path of the sighting mechanism optical system and said beam path of the laser receiver being at least partially coextensive;

a divider mirror mounted in the beam path of said laser receiver for transmitting received rays from the target to said laser receiver and for reflecting received rays from the target for direction to said ocular of said sighting mechanism optical system;

a two-member optical system arranged in the beam path of said laser transmitter;

8

a reticle plate mounted in front of said divider mirror in the beam path of the laser receiver and the sighting mechanism optical system and coupled to one member of said two-member optical system for displacement in a plane transverse to the optical axis of such two-member optical system, such displacement adjusting the elevation angle required for a projectile to reach the target;

means for passing to said laser receiver that portion of the rays reflected from the target which correspond in direction and divergence to the transmitted rays and to which said laser receiver is responsive, and for blocking the other rays to which said laser receiver is responsive, said means for passing and for blocking the rays being a fixed diaphragm mounted in front of said laser receiver;

means coupled between the laser receiver and the reticle plate and responsive to signals from said laser receiver for displacing the reticle plate and said one member of the two-member optical system in said transverse plane thereby to adjust for the elevation angle required for a projectile to reach the target; and

a further two-member optical system arranged in front of said fixed diaphragm, one member of said further two-member optical system being adjacent to said reticle plate and connected therewith for displacement transverse to the optical axis of a portion of the sighting mechanism optical system, said further two-member optical system providing a parallel beam path therebetween and producing the image of said reticle plate in the diaphragm plane.

References Cited

UNITED STATES PATENTS

3,339,457 9/1967 Pun.

RONALD L. WILBERT, Primary Examiner

F. L. EVANS, Assistant Examiner

U.S. Cl. X.R.

356-252

April 7, 1970

G. W. BICKEL ET AL

3,505,528

RANGE FINDER WITH RADIATION SENSITIVE MEANS BEHIND REFLECTOR

Filed Aug. 16, 1967

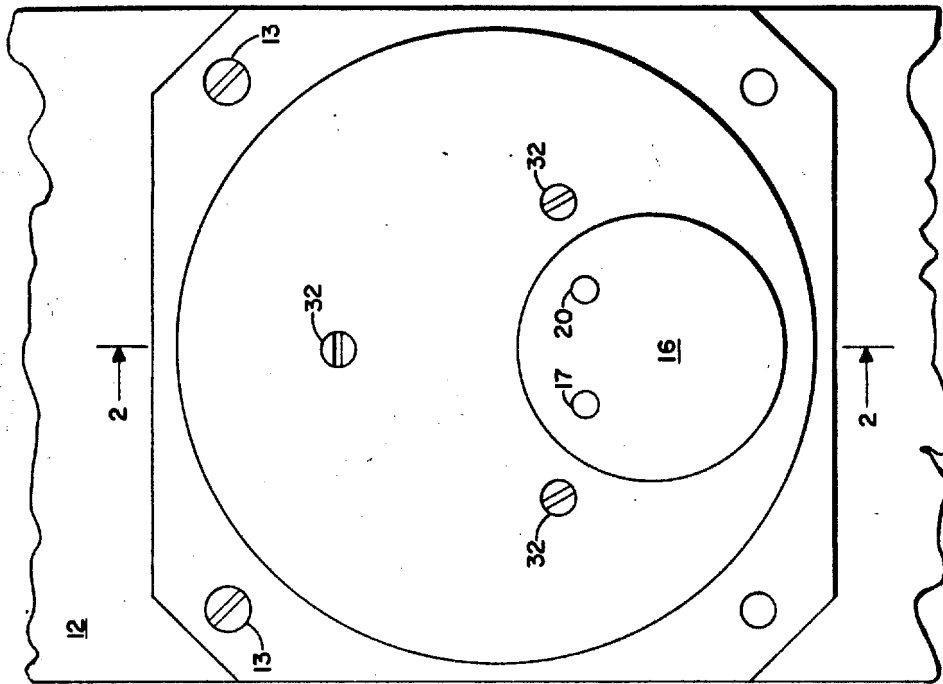

FIG. 1

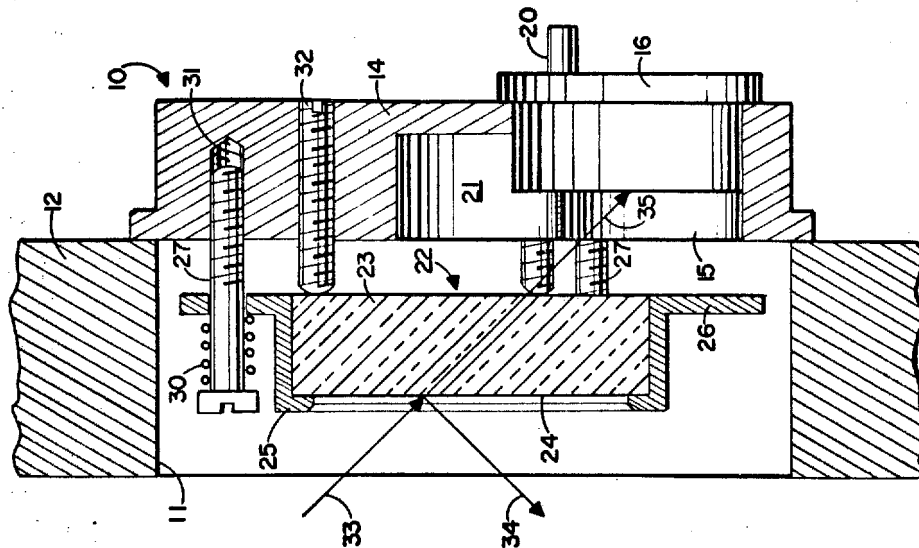

FIG. 2

INVENTORS
GARY W. BICKEL
JOHN J. FERRARA
MARVIN L. LIPSHUTZ
BY *Geyenfeld*
ATTORNEY

1

2

3,505,528

RANGE FINDER WITH RADIATION SENSITIVE MEANS BEHIND REFLECTOR

Gary W. Bickel, Boston, John J. Ferrara, Acton, and Marvin L. Lipschutz, Brookline, Mass., assignors to Honeywell Inc., Minneapolis, Minn., a corporation of Delaware

Filed Aug. 16, 1967, Ser. No. 661,069

Int. Cl. H01j 5/16; H01l 15/00

U.S. Cl. 250—216

2 Claims

ABSTRACT OF THE DISCLOSURE

An integrated first-surface reflector and transducing sensor, in a kinematic mount, for use in optical systems such as laser range finders, the sensor being positioned behind the reflector to use the small amount of light unavoidably transmitted therethrough.

BACKGROUND OF THE INVENTION

This invention relates to the field of optical instruments and more expressly to laser range finders. It is frequently desirable to provide an optical instrument with means for making known the exact instant when a beam of light is received or transmitted. One method of accomplishing this has been to insert a fiber optics tap into the optical path, but this has the disadvantage of reducing the available light intensity by reducing the effective area of the beam.

SUMMARY OF THE INVENTION

Our invention may be used wherever the light path requires a reflecting surface and where the light is of suitable intensity. It comprises a photodiode mounted behind the reflecting surface, to make use of the otherwise wasted light energy transmitted through the reflecting surface, which is typically a layer of metal on the surface of a block of optical glass.

BRIEF DESCRIPTION OF THE DRAWING

In the drawing FIGURE 1 is a view enlarged of an assembly embodying the invention and FIGURE 2 is the section taken along the line 2—2 of FIGURE 1.

DESCRIPTION OF THE PREFERRED EMBODIMENT

Our invention comprises an assembly 10 mounted in an aperture 11 in the housing 12 of an optical instrument such as a laser range finder by suitable means such as screws 13. Assembly 10 includes a backing member 14 having a bore 15 to receive a photodiode 16 having terminals 17 and 20, the sensitive surface of the diode being within bore 15 which is enlarged at 21 to avoid occultation of the sensor. Diode 16 is pressed or otherwise suitably retained in bore 15.

A mirror 22 includes a block 23 of optical glass having a first reflective surface 24, and is received in a cap 25 having a flange 26 traversed by a plurality of mounting screws 27 which pass through compression springs 30 and which are received in thread bores 31 in member 14. The rear surface of block 23 is engaged by the ends of a plurality of adjusting screws 32. Screws 27 and 32 cooperate with springs 30 to comprise a kinematic mount for mirror 22.

Assembly 10 is so positioned with respect to housing 12 as to receiving a beam of light, specifically laser light, which is shown at 33, and to reflect as large a portion as possible of that light, as shown at 34. It is unavoidable that a certain minor portion of the incident light is not reflected but transmitted through surface 24, as at 35, to impinge on photodiode 16.

OPERATION

Whenever light of suitable intensity is supplied at 33, a portion thereof acts at 35 to energize diode 16, which thereafter gives an electrical output. This output can be used for any desired purpose: in one embodiment of the invention the diode signal was used as an indicator of zero time for a laser range finder, since it occurred at the instant when a laser pulse was transmitted at 34 to emerge from the output optics of the device.

In the foregoing disclosure of the invention we have set forth details and advantages of its structure and function, and the operation and the novel features thereof are pointed out in the appended claims. The disclosure, however, is illustrative only, and changes may be made within the principle of the invention, to the full extent indicated by the broad general meaning of the terms in which the appended claims are expressed.

We claim as our invention:

1. Apparatus for indicating the presence of a beam of light comprising, in combination: a mirror comprising a block of optical glass, having a plane front surface coated with metal to form a reflector, and a flanged mounting cap enclosing said block and apertured to expose said front surface reflector;

a backing member including adjustable spacing means projecting therefrom;

means securing said mirror to said backing member with the rear surface of said block in contact with said spacing means, including means traversing the flange of said cap and resiliently urging said cap toward said backing member while preventing significant lateral movement therebetween;

means for mounting said member so that said front surface reflector is positioned to reflect radiant energy impinging thereon; and

detector means comprising a photodiode mounted in said backing member to receive a portion of the radiant energy transmitted through said reflector and said block.

2. Apparatus for indicating the presence of a beam of light comprising, in combination: a mirror comprising a block of optical glass, having a plane front surface coated with metal to form a reflector and a flanged mounting cap on closing said block and apertured to expose said front surface reflector;

a backing member including adjustable spacing means projecting therefrom;

means securing said mirror to said backing member with the rear surface of said block in contact with said spacing means, including means traversing the flange of said cap and resiliently urging said cap toward a said backing member while preventing significant lateral movement therebetween;

means for mounting said member so that said front surface reflector is positioned to reflect radiant energy impinging obliquely thereon; and

detector means comprising a photodiode mounted eccentrically in said backing member to receive a portion of the radiant energy transmitted through said reflector and said block.

References Cited

UNITED STATES PATENTS

| | | | |
|-----------|--------|---------------|-----------|
| 2,547,545 | 4/1951 | Strong | 356—209 X |
| 2,873,381 | 2/1959 | Lauroesch | 250—236 |
| 3,049,964 | 8/1962 | Miller et al. | 356—209 X |

WALTER STOLWEIN, Primary Examiner

U.S. Cl. X.R.

356—4

Approved For Release 2009/04/10 : CIA-RDP81-00120R000100010021-3
June 23, 1970

D. C. MCKOWN ET AL

3,310,173

LASER RADAR SYSTEM

Filed Sept. 10, 1965

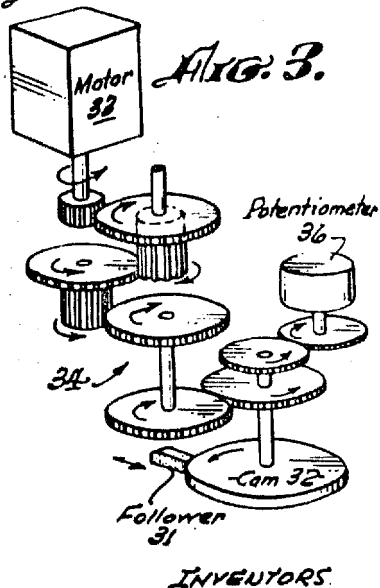
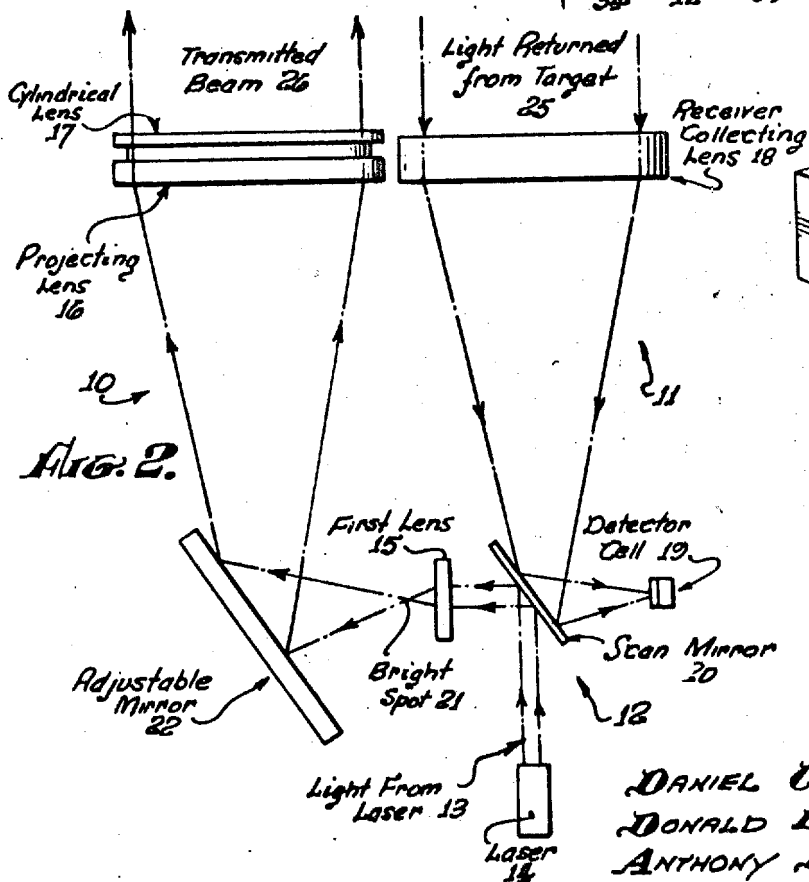
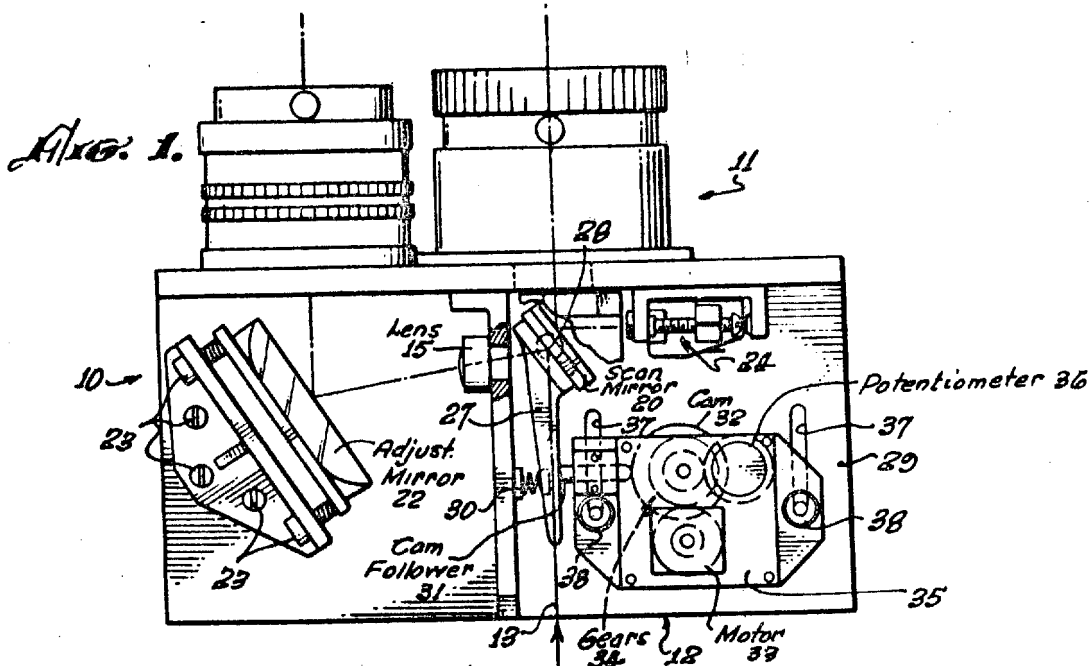

INVENTORS.
DANIEL C. MCKOWN,
DONALD E. HOWLETT,
ANTHONY DI TOMMASO,

By  ATTORNEY.

1

3,516,743

LASER RADAR SYSTEM

Daniel C. McKown, Chino, Donald E. Howlett, Riverside, and Anthony Di Tommaso, Upland, Calif., assignors to General Dynamics Corporation, Pomona, Calif., a corporation of Delaware
Filed Sept. 10, 1965, Ser. No. 486,507
Int. Cl. G01c 3/08

U.S. Cl. 356-4

12 Claims

ABSTRACT OF THE DISCLOSURE

A compact optical system which changes the transmitted output of a laser unit into a slender rectangular beam which is scanned back and forth at right angles to the length of the rectangle while, simultaneously, the field of view of associated receiver optics is scanned across a detector unit in synchronism with the scanning motion of the transmitted beam.

Optical systems for tracking of laser-illuminated targets are known in the art. Such systems include optical transmitter and receiver combinations for transmitting energy and receiving echoes reflected back from target objects. In most of the known systems the transmitter and receiver are made separately and are used at spaced positions so that the transmitted signal is reflected back through some angle from a target object to a receiver. Such devices present problems of accurately directing each transmitter and receiver for target object picked up and of coordinating the transmitter and receiver relation for object tracking.

Composite optical transmitter and receiver devices have been developed that utilize annular transmitter and receiver reflectors so that the signals are transmitted and received concentrically or coaxially to and from a target object.

The present invention utilizes optical transmitter and receiver devices which move in unison and function to transform the output of a laser crystal into a beam whose cross section is a slender rectangle, and to scan the rectangular beam back and forth in a direction at right angles to the length of the rectangle while simultaneously scanning the receiver field of view across detector cells or an eyepiece in synchronism with the scanning motion of the transmitter fan beam.

Therefore, it is an object of this invention to provide an optical system.

A further object of the invention is to provide an optical system having synchronized transmitting and receiving optics.

Another object of the invention is to provide an optical system for a laser radar.

Another object of the invention is to provide an optical system for a laser radar where the transmitting and receiving optics are inter-related through a scanning mechanism which causes the receiver to be always looking at whatever objects the transmitter is illuminating.

Another object of the invention is to provide an optical system which transforms the output of a laser crystal into a beam whose cross section is a slender rectangle, and to scan the rectangular beam back and forth in a direction at right angles to the length of the rectangle while simultaneously scanning the receiver field of view across a detector unit in synchronism with the scanning motion of the transmitter fan beam.

Other objects of the invention, not specifically set forth above, will become readily apparent from the following description and accompanying drawing wherein:

2

FIG. 1 is a plan view of an embodiment of a transmitter-receiver unit utilizing the optical system of the invention;

FIG. 2 is a schematic illustration of the inventive optical system; and

FIG. 3 is a perspective view of the drive assembly for the optical system.

Broadly, the invention, as illustrated, relates to an optical searching device comprising a laser, a transmitting channel, a receiving channel and detecting means. Alignment of the transmitter and receiver in the searching mode is accomplished by the use of a two sided scan mirror, alternate sides of the mirror cooperating on the one hand with the laser beam to scan a given area, and on the other with detector cells to align their field of view with the beam. Specifically, the system comprises transmitting optics including a first lens and an adjustable mirror which deflects the laser output to beam shaping optics comprising a projecting lens and a cylindrical lens. In the receiver a single collecting lens is interposed between the scan mirror and the reflected energy. A synchronized drive assembly is utilized to operate the scan mirror.

Referring now to the drawings, the device illustrated is the optical system of a laser radar. The optical system consists of two main parts, the transmitting optics indicated generally at 10 and the receiving optics indicated generally at 11. These two parts are interlocked through the scanning mechanism indicated generally at 12, which causes the receiver 11 to be always looking at whatever objects the transmitter 10 is illuminating.

The transmitting optics 10 receives the output or beam 13 of a laser crystal indicated at 14, which is a beam of circular cross section, and forms it into a beam of rectangular cross section. In the process of transforming the beam 13, the transmitting optics 10 reduces the beam divergence in one dimension and increases its divergence in the other dimension. This is done in two stages. A collimator comprising a first lens 15 and a projecting lens 16 is used to reduce the beam divergence in both dimensions and then a cylindrical lens 17 is used to increase the divergence in one dimension.

The receiving optics includes a lens 18 which images the target complex onto the detector cell or cells 19. The target is regarded as being at infinity because its distance from the receiver collecting lens 18 is many times the focal length of the receiving optics 11. Scanning is accomplished by the use of a single two-sided plane mirror 20 oscillated by the mechanism shown in FIGS. 1 and 3. The light to be transmitted is reflected from one side of the mirror 20, and the received light is reflected from the other side. Because both reflecting surfaces are deposited on the same substrate, any rotation of the substrate will be faithfully converted into a proportional rotation of both the transmitted beam and the receiver field of view.

As shown in FIG. 2, the beam 13 of light from a laser 14 is first reflected by the scan mirror 20 onto the first lens 15 of the collimator which focuses the beam into a bright spot indicated at 21. Because of the oscillating motion of the scan mirror 20, the focal point or bright spot 21 moves back and forth, thereby providing the basis for the scanning motion of the transmitted beam, this being accomplished by the drive assembly illustrated in FIGS. 1 and 3 described in detail hereinafter. After passing through the focal point or bright spot 21, the rays diverge as they move toward a projecting lens 16 via an adjustable mirror 22. After passing through the projecting lens 16, the rays are nearly parallel. The divergence of this nearly parallel

3,516,743

3

beam is related to the divergence of the original beam 13 from the laser 14 as follows:

$$f_1\theta = f_p\phi$$

where:

f_1 =focal length of the first lens 15

f_p =focal length of the projecting lens 16

θ =divergence of the laser 14 output

ϕ =divergence of output from projecting lens 16

Because the ratio of f_p to f_1 would typically be 5 to 1, the output beam divergence is only one fifth the divergence of the input laser beam. This output beam divergence is satisfactory for the narrow dimension of the rectangular beam cross section, but the divergence is not great enough for the longer dimension of the beam.

To broaden the beam in the long dimension, the diverging (negative) cylindrical lens 17 is inserted into the optical path following the projecting lens 16. The resulting long dimension of the beam is:

$$\phi + 2 \text{ arc ctn } \frac{2fc}{d}$$

where:

ϕ =divergence of output from projecting lens 16

fc =focal length of cylindrical lens 17

d =diameter of the bundle of rays falling on the cylindrical lens 17

The adjustable mirror 22 is used in the transmitted beam path between the first lens 15 and the projecting lens 16 to change the direction of the rays and to provide an adjustable capability which is accomplished via adjustment screws indicated at 23 in FIG. 1.

The receiving optics 11 consists of the receiver collecting lens 18 and the scan mirror 20. The receiver collecting lens 18 focuses the rays toward the detector cell or cells 19 which is adjustably mounted by the mechanism indicated at 24 in FIG. 1, the cell being omitted in FIG. 1 for clarity. Along the optical path between the receiver collecting lens 18 and the detector cell or cells, the rays are reflected by the scan mirror 20 which changes their direction and imposes a scanning motion on the image formed at the detector cell 19 which lies in the image plane of the receiver collecting lens 18. This scanning motion is provided through the drive assembly illustrated in FIGS. 1 and 3 and described hereinbelow.

The detector cell 19 remains motionless. It is desired that the detector cell 19 always receives the radiation indicated at 25 returned from the spot or target illuminated by the scanning transmitted beam 26. Therefore, the scene formed by the receiver collecting lens 18 must be scanned across the detector cell 19 by exactly the right amount to keep the image of the moving illuminated spot or target centered on the detector cell. To achieve this degree of synchronism, the present invention makes use of the scan mirror 20 which is silvered on both faces for use by the transmitter 10 and receiver 11. Thus, the common scan mirror 20 produces identical movements of the rays in the transmitting and receiving portions of the optical system. Because the projecting lens 16 and the receiver collecting lens 18 have different focal lengths, the necessary condition for synchronism is that:

$$\frac{r}{f_R} = \frac{f_1}{f_p}$$

where:

r =distance of receiver image plane from scan mirror 20.

In practice, the distance r is varied systematically until synchronism is achieved.

Referring now to the scan mirror drive assembly illustrated in FIGS. 1 and 3, a lever member 27 is operatively

4

at 28 on the housing 29 of the optical system. Lever 27 is spring biased in one direction by spring 30 and in the opposed direction by cam follower 31 driven by cam 32 which in turn is driven by a prime mover or motor 33 via a gear train indicated generally at 34, the gear train 34 being mounted in a support member 35. The motor 33 may be electric or other suitable type.

A potentiometer 36 is also driven through gear train 34 and functions to determine the angular position (phase) of the cam 32 and thus providing a means whereby the target location can be read out electrically at the instant the target is registered by the detector cell or cells 19.

Housing 29 is provided with a pair of slots 37 which permits the drive assembly for lever 27 to be moved toward or away from the scan mirror 20 whereby the scan mirror 20 can be moved through different scan angles to enlarge or decrease the field scanned due to the cam follower action on different effective lever arm lengths of lever 27. Screws or other attaching means indicated at 38 serve to hold the support housing 35 of the drive assembly fixed in slots 37.

It is thus seen that the present invention provides a laser radar having an optical system which utilizes a single scanning mirror to insure synchronism between the transmitter and receiver functions. Also, the novel use of the cylindrical lens to form a beam having a rectangular cross section thereby provides an advance over the prior known systems.

Although a rectangular beam cross section is utilized herein, the scan synchronizing technique is equally applicable to other beam shapes such as multiple fan beams or V-beams, however the forming optics for such beams would be different.

By substituting an eyepiece and a human observer in place of the detector cell, the system could be used for visual scanning with illumination. This approach could be useful in directing a searchlight beam against an aircraft, due to the observer's eye remaining fixed during the scanning.

Although a particular embodiment utilizing the invention has been illustrated and described, modifications will become apparent to those skilled in the art, and it is intended to cover in the appended claims all such modifications as come within the true spirit and scope of the invention.

What we claim is:

1. A laser radar comprising, in combination, a laser unit, synchronized transmitting and receiving optics, and detecting means, said laser unit being operably disposed to transmit a laser beam to an associated target via said transmitting optics; said receiving optics being operably disposed to receive a laser beam reflected from said associated target and to direct said reflected beam to said detecting means; said transmitting and receiving optics including a dual sided mirror-like scanning means operably disposed between said transmitting optics and said receiving optics for synchronizing said receiving optics with said transmitting optics; and means operably connected to said scanning means for moving said scanning means; said transmitting optics additionally including an adjustable mirror, a first lens operably disposed between said scanning means and said adjustable mirror for directing said laser beam onto said adjustable mirror for reflection therefrom, a second lens operably disposed to receive said reflected laser beam from said adjustable mirror, said second lens causing the rays of said reflected laser beam to diverge to a substantially parallel pattern, and a third lens operably located adjacent said second lens to receive said substantially parallel rays of said reflected laser beam and to broaden said beam in a long dimension; said scanning means being pivotally mounted for reflecting said laser beam onto said first lens while simultaneously reflecting the received beam onto said detecting means; the

3,516,743

5

changes in the direction of the respective beams reflected from said scanning means.

2. The laser radar defined in claim 1, wherein said receiving optics additionally includes a lens for collecting the beam rays reflected from said associated target and focusing the rays toward the detecting means via said scanning means.

3. The laser radar defined in claim 2, wherein said dual sided scanning means consists of a plane mirror silvered on both faces which thus produces identical movements of the rays being transmitted and received.

4. The laser radar defined in claim 3, wherein said means for moving said scanning means includes a prime mover, gear means drivingly connected to said prime mover for movement by said prime mover, a cam operatively connected to said gear means and responsive to the movement of said gear means, a cam follower operably disposed relative to said cam and responsive to movements of said cam, a lever operatively connected to said scanning means and to said cam follower, said cam follower biasing said lever in one direction to move said scanning means, and bias means operatively connected to said lever and responsive to movements of said cam and cam follower for biasing said lever in a direction opposed to that of said cam follower.

5. The laser radar defined in claim 4, wherein a potentiometer is drivingly connected to said gear means.

6. The laser radar defined in claim 5, additionally including means operably connected to said detecting means for adjustably positioning said detecting means.

7. An optical system comprising: a source of light, transmitting optics from transmitting light from said source to a target, receiving optics for receiving light returned from said target, and means operably disposed, between said transmitting optics and said receiving optics for synchronizing said receiving optics with said transmitting optics; said synchronizing means comprising a pivotally mounted dual sided mirror-like means, and means operably connected to said mirror-like means for oscillating said mirror-like means; said transmitting optics comprising an adjustable mirror, a first lens operably disposed between said dual sided mirror-like means and said adjustable mirror, a second lens, said adjustable mirror operably positioned between said first and second lenses, and a third lens located on the side of said second lens opposite said adjustable mirror; said pivotally mounted

6

mirror-like means reflecting the light from said source onto said first lens while simultaneously reflecting the returned light onto detecting means; the oscillation of said mirror-like means causing corresponding changes in the direction of the respective beams reflected from said mirror-like means.

8. The optical system defined in claim 7, wherein said receiving optics includes a collecting lens.

9. The optical system defined in claim 8, wherein said means for oscillating said dual sided mirror-like means includes a lever means operatively connected to said mirror-like means, biasing means operatively connected on one side of said lever means for biasing said lever means in one direction, and means operatively connected on the side of said lever means opposite said biasing means for driving said lever means against said biasing means.

10. The optical system defined in claim 9, wherein said driving means includes a cam and cam follower.

11. The optical system defined in claim 10, wherein said cam and cam follower are driven by a prime mover via gear means operatively connected to said prime mover and to said cam and cam follower for driving said cam and cam follower.

12. The optical system defined in claim 11, additionally including means driven by said oscillating means for determining the angular position or phase angle of said cam.

References Cited

UNITED STATES PATENTS

| | | | |
|-----------|---------|--------------|---------|
| 3,364,358 | 1/1968 | Answorth | 250-219 |
| 2,750,836 | 6/1956 | Fastie | |
| 3,278,753 | 10/1966 | Pitts et al. | |
| 3,293,438 | 12/1966 | Davis | |

FOREIGN PATENTS

992,760 5/1965 Great Britain.

RONALD L. WIBERT, Primary Examiner

F. L. EVANS, Assistant Examiner

U.S. Cl. X.R.

350-6, 289, 300

Oct. 13, 1970

H. G. DE WINTER

3,533,696

LASER RANGE FINDER INCLUDING A LIGHT DIFFUSING ELEMENT

Filed July 8, 1966

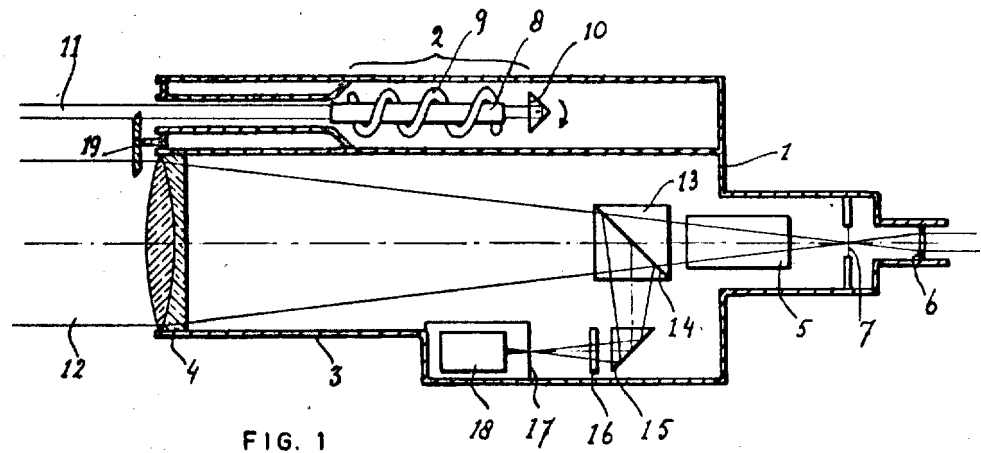

FIG. 1

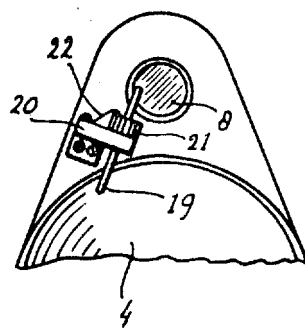

FIG. 2

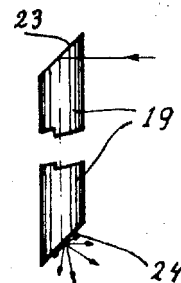

FIG. 3

INVENTOR
Hennanus Gerardus de Winter
BY
Arthur B. Colvins
ATTORNEY

1

2

3,533,696

LASER RANGE FINDER INCLUDING A LIGHT
DIFFUSING ELEMENT

Hermanus Gerardus de Winter, Enschede, Netherlands,
assignor to N.V. Optische Industrie "De Oude Delft,"
Delft, Netherlands, a corporation of the Netherlands
Filed July 8, 1966, Ser. No. 563,764

Int. Cl. G01c 3/08

U.S. Cl. 356-4

2 Claims

ABSTRACT OF THE DISCLOSURE

A laser range finder device in which a small sample of the pulsed light beam transmitted by the laser head is fed back to the receiver optics along an optical path including a light diffusing element.

The invention relates to laser apparatus and, more particularly, to laser range finders and like devices which comprise a laser transmitter to transmit a pulsed beam of radiation toward a target, an optical objective system for receiving a beam of reflected laser radiation from such target and a detector for detecting such reflected radiation.

Devices of this kind form an important field of application for lasers. They may be used, e.g. in conjunction with suitable electronic counters to measure the time lapse between the transmittal of a pulse by the laser and the reception of a reflected pulse from the target whereby the distance to such target can be determined. In addition to range finders in the strict sense, e.g. optical radar systems fall into the category of apparatus to which the invention is applicable.

In order to accurately define the zero point of the time measurement a sample of the radiation pulse transmitted by the laser is directly fed to a radiation detector. The electric pulse thus generated may be used to start an electronic counter or utilized in any other manner according to the specific purpose of the device envisaged.

It has hitherto been common to provide a separate detector for generating the zero pulse and such detector is placed beside the laser beam and receives a fraction of the laser beam either from a small mirror projecting into the laser beam or from a wire grid which is positioned in front of the laser and scatters some of the radiation thereof into the direction of the zero pulse detector.

It is an object of this invention to provide simple means to guide a required amount of radiant energy from the laser beam to the detector detecting the radiation reflected by the target, so that the same is also utilized as zero pulse detector. It is a further object to provide such means which permits the amount of energy from the laser beam that is incident on the detector to be easily adjusted within wide limits. A still further object is to provide such means which does not require critical adjustments to ensure that a sample of the laser beam is incident on the detector.

In accordance with the invention, broadly, means are provided to diffuse a portion of the radiation of the pulsed beam transmitted and to make such diffused radiation incident on the optical objective system so that a sample thereof is detected by the same detector which detects the reflected radiation. In a preferred embodiment optically active surfaces are placed in the laser beam transmitted and in the reflected beam entering the optical objective system so that radiation from the laser beam transmitted is directed into the objective system via said surfaces, and at least one of these surfaces has radiation diffusing properties. More specifically, the surface in the laser beam transmitted may be a mirror reflective surface

placed at an angle to the beam, axis, whereas the surface in the reflective beam is a diffusely reflective or diffusely transmissive surface. In order to permit adjustment of the intensity of the sample of radiation coupled back to the detector, the angle of any of such surfaces, or of both, relative to the respective beam axes may be made adjustable.

A particularly simple embodiment is achieved by providing a rod-like element of a material which is transparent to the laser radiation and one end of which projects into the laser beam transmitted and is so shaped that a portion of that beam enters the element and is guided thereby toward the other end of the element which projects into the reflected beam and has a diffusing exit surface for the radiation. Suitably, such element is a straight rod which is supported in a plane substantially perpendicular to the laser beam axis so as to be rotatably adjustable about its own axis, and has two beveled end faces one of which at least has radiation diffusing properties.

The radiation diffusing surface in the device according to the invention ensures that in all circumstances radiation from the laser beam will be incident on the optical receiver within the extremely small spatial angle from which radiation is passed on to the detector, without having to resort to delicate adjustments which other available means, such as mirrors, would require. On the other hand it provides automatically the necessary weakening of the radiant energy before reaching the detector. Since the zero pulse and the echo pulse are both produced by the same detector and processed by the same electronic circuits, the intensities of the direct laser radiation and the reflected radiation on the detector should be in the same order and this may necessitate an attenuation of the laser beam by a factor of, e.g. 10^6 to 10^8 . This is brought about by scattering almost all of the laser radiation picked up from the beam outside the small spatial angle which the optical receiver system passes on to the detector and which may be in the order of 1 milliradian. Furthermore, by adjusting the angular positions of the diffusing and/or reflective surfaces in the device described, their apparent area or their effectiveness in directing radiant energy toward the detector can be controlled with a view to varying within wide limits the amount of energy incident on the detector.

The drawing illustrates diagrammatically a preferred embodiment of a laser range finder constructed in accordance with the invention. In the drawings:

FIG. 1 shows the device in longitudinal cross section;

FIG. 2 shows a partial front view; and

FIG. 3 shows the coupling element of the device at a larger scale.

In FIG. 1, the housing 1 of the device has two compartments separated from each other by a light tight partition. In the upper compartment a laser device 2 is housed, whereas the lower compartment contains a telescope 3 diagrammatically shown as comprising an objective 4, a prism image inverting system 5 and an eye piece 6. The laser and telescope axes are parallel. In the focal plane of the eye piece a recticle 7 is provided to permit accurate sighting on a target the distance to which is to be measured.

The laser which generally will produce infrared radiation, has in the embodiment illustrated a ruby rod as its active medium, which is optically "pumped" by means of a helical flash lamp 9. High energy pulses of very short duration are generated by means of a roof prism 10 which borders the laser cavity on one side and can be rotated very fast by driving means not specifically shown in the drawing, a technique well-known in the art as Q-switching. The resulting pulsed beam of monochromatic coherent small spatial

3

angle and is accurately parallel to the axis of the telescope 3.

A parallel beam 12 of radiation which has been reflected by the distant target is focused by the objective 4. In the convergent beam behind the objective a beam splitting prism 13 is positioned which is preferably provided with a dichroit surface 14 which, in well-known manner, is virtually transparent for visible light but selectively reflects infrared components of the incident radiation including the laser radiation toward a prism 15. Through a narrow pass-band filter 16 the laser radiation falls on a diaphragm or field stop 17 which is positioned in the plane of best focus and has a pin point aperture corresponding to the target point to which the laser beam has been directed. The radiation admitted by the aperture is detected by a photomultiplier 18. Whereas through the eye piece 6 the whole field of the telescope 3 may be observed the photomultiplier 18 receives only the reflected laser radiation from a small target in the center of such field.

To derive a starting or zero pulse for the time measurement a sample of the radiant energy of the laser beam 11 is coupled back to the photomultiplier 18 directly by means of a rod 19 of a material which is transparent to the laser radiation and which has one end projecting into the laser beam whereas the other end projects into the reflected beam 12. The manner in which the rod is mounted appears best from FIG. 2, whereas FIG. 3 shows the end portions of the rod on an enlarged scale.

The rod is cylindrical in shape and rotatably mounted in a hole of a support 20 attached to the instrument housing 1. A milled ring 21 fixed to the rod 19 facilitates its angular adjustment and a blade spring 22 maintains the rod in the selected position.

Both end surfaces of the rod 19 are beveled at 45° with the rod axis (FIG. 3). Surface 23 is optically polished flat and serves to deviate by total reflection incident radiation from the laser beam entering the rod through its cylindrical surface towards the exit surface 24. This latter surface has been made diffuse, e.g. by grinding, such that radiation reaching this surface is scattered in a wide spatial angle, as illustrated by the bundle of arrows in FIG. 3. Thus, an extremely small fraction only of this radiation will enter the objective 4 at such an angle as to be admitted by the pin hole of the field stop 17 to the detector 18. On the other hand, the rod need not be adjusted to any precision since the scattering at the diffusing surface 24 ensures that some of the laser radiation will in all circumstances be within the small field angle which the objective 4 focuses on the pin hole of field stop 17. The amount of energy actually incident on the detector can be easily adapted to the requirements of the detector and its related circuitry by rotating the rod 19. Thereby the angle at which the laser beam sees the surface 23 and hence the apparent effective area of this surface is varied, as well as the percentage of the radiation leaving the rod at surface 24 which eventually falls on the detector 18. The latter is true since, generally, the diffusion caused at surface 24 will not be such that the intensity of the resultant radiation is equal in all directions.

Many modifications may be applied to the apparatus shown and described without giving up its essential advantages and without leaving the domain of the invention in its broader aspects. As an example, it is within the scope of the invention to utilize separate small reflectors in the laser beam and in the reflected beam at angles with

4

respect to the beam axes such that the reflector in the reflected beam receives some of the radiation deviated by the reflector in the laser beam. At least one of these reflectors may have diffusing properties, or a separate diffusing element, such as a ground glass, may be mounted in the optical path defined by the reflectors. Alternatively, a reflector in the laser beam may be omitted and a diffusing element of any kind, such as a grid, may be provided therein, in combination with a mirror in the reflected beam, to transmit some of the scattered radiation to the optical receiver. Preferably, in devices for military purposes it should be avoided, however, to use a diffusing element in the laser beam that scatters radiation in forward directions also, since this would facilitate detection of the range finders by enemy forces. Finally, it will be understood that a rod-like element like the one described, instead of being straight, could have curved end portions and light entrance and exit surfaces perpendicular to the beam axes of which at least one has light diffusing properties.

What I claim is:

1. In a laser range finding device comprising a laser transmitter to transmit a pulsed beam of radiant energy concentrated in a narrow spatial angle toward a target; an optical receiver including an objective for focusing a parallel beam of radiant energy reflected from said target in a focal plane, a pin hole field stop in said focal plane to discriminate between reflected radiant energy entering said objective within said narrow spatial angle and other radiation, and a detector disposed behind said field stop for detecting such reflected radiant energy; a mirror reflective surface placed in said transmitted pulsed beam at an oblique angle to the laser axis for deflecting a sample of said transmitted pulsed beam so as to become incident on said objective, and a diffusing surface placed in front of said objective at an angle to the objective axis, for optically diffusing said sample before entering said objective, whereby some of the radiant energy in said sample is projected by said objective on the pin hole of said field stop and received by said detector, the angle of at least one of said mirror reflective surface and said diffusing surface being adjustable.

2. The device defined in claim 1, wherein said mirror reflective surface and said diffusing surface are beveled end faces of a radiation transparent rod supported in a plane perpendicular to the laser axis and rotatably adjustable about its own axis.

References Cited

UNITED STATES PATENTS

| | | | |
|-----------|---------|-------------------|-------|
| 2,577,815 | 12/1951 | Saunderson et al. | 88-14 |
| 3,150,363 | 9/1964 | Finvold. | |
| 3,373,441 | 3/1968 | Zadig. | |

OTHER REFERENCES

NEREM Record, 1962, session 3: Highlights of Army Communications and Electronics R&D. Nov. 5, 1962.

RONALD L. WIBERT, Primary Examiner
V. P. MCGRAW, Assistant Examiner

U.S. Cl. X.R.

356-256

April 3, 1951

M. SCHWARTZ ET AL

2,547,232

RANGE FINDER WITH LIGHT BEAM CORRECTION

Filed Feb. 28, 1946

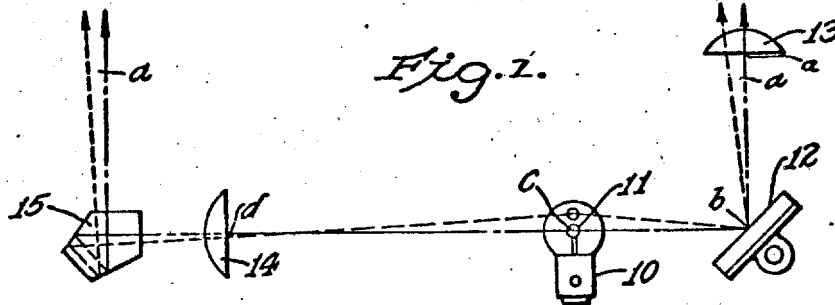

Fig. 2.

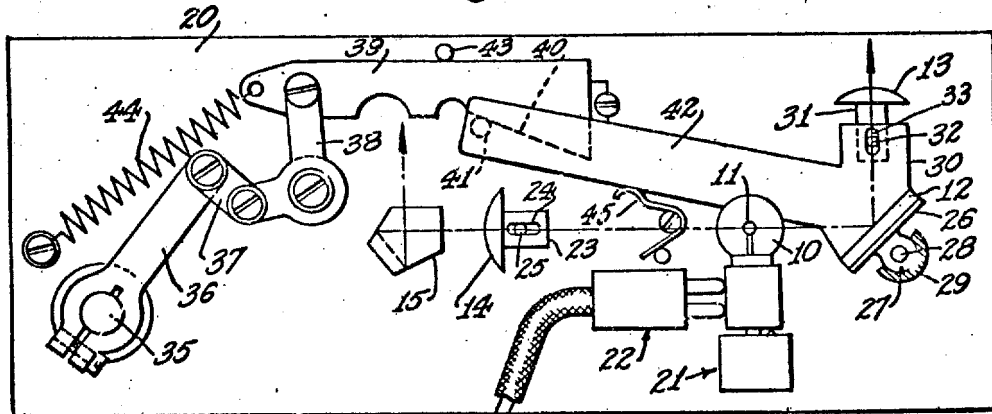

Fig. 3.

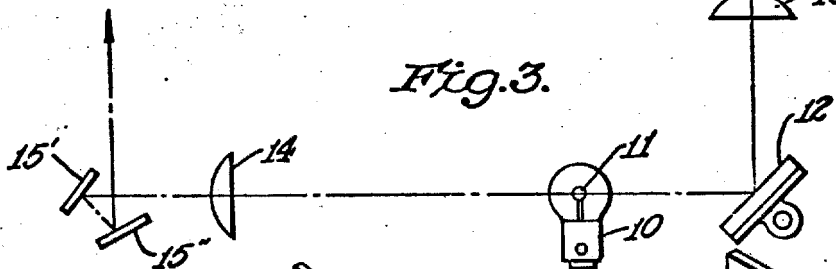

Fig. 4.

Fig. 5.

INVENTORS
MORRIS SCHWARTZ
WILLIAM CASTEDELLO
BY *Federick G. Haus*
ATTORNEY

Patented Apr. 3, 1951

2,547,232

UNITED STATES PATENT OFFICE

2,547,232

RANGE FINDER WITH LIGHT BEAM
CORRECTION

Morris Schwartz and William Castedello, Stamford, Conn., assignors to The Kalart Company Inc., Stamford, Conn.

Application February 28, 1946, Serial No. 650,927

7 Claims. (Cl. 38-2.7)

1

This invention relates to light beam projecting range finders, particularly to range finders of the type in which a source of light is positioned between two light deviating means or reflectors, one of which is movable, and in which the angular position of the movable reflector relative to the stationary one is employed, either to ascertain the range of an object or to focus the lens of a photographic camera, the latter type of range finders being sometimes referred to as "lens coupled range finders."

The word "camera," as used herein, is intended to include apparatus for the taking of photographs as well as devices, such as moving picture projectors, television cameras, enlargers, and the like, or in other words, any device comprising a lens to be focused on an object or screen.

In range finders of the type above referred to, the source of light usually comprises an electric lamp having an incandescent filament, two images of which are viewable on the object. The relative position of these images is varied by means of the movable reflector, and the two images are brought into a predetermined position relative to each other which is indicative of the range of the object.

As will be evident to a person skilled in the art, the accuracy of a range finder of the type above referred to will be affected by a variation of the position of the lamp filament relative to the two reflectors because any variation of the filament position will cause the images to be viewable on the object in a different relative position for a given range of the object. It has been found that in electric lamps, as commercially available on the market, the filament is not always in the same position. Furthermore, the lamp will not always be inserted in the socket in the same position. As a result, when a new lamp is inserted, it may be found that the filament of such new lamp is changed relative to a plane parallel to an axis between the two reflectors, and/or that the filament of the new lamp is slightly tilted relative to a plane through the filament of the old lamp. Either such change of the filament position will result in altered light paths.

An arrangement for correction of a tilting of the lamp has been fully described and disclosed in the co-pending application, Ser. No. 648,726, filed February 19, 1946, by Morris Schwartz and William Castedello, which application is now abandoned.

The object of this invention is to provide means for correcting any inaccuracy caused by a

2

change of the filament position relative to a plane through or parallel to an axis between the two reflectors is automatically corrected.

Another object of the invention is to provide means which correct a variation of the light paths, as caused by a change of the filament position relative to a plane through or parallel to an axis between the reflectors without requiring an adjustment of any component parts of the range finder.

Another object of the invention is to provide optical means which maintain the two beams projected by the range finder always parallel to each other for all adjustments of the range finder requiring such parallelism of the light beams independently of a variation of the filament position relative to the reflectors.

Other and further objects, features and advantages of the invention will be set forth hereinafter and the novel features thereof defined by the appended claims.

The present application is a continuation in part of the co-pending application Ser. No. 494,872, filed on July 15, 1943, by Morris Schwartz and William Castedello and issued as Letters Patent 2,403,308 on July 2, 1946.

In the accompanying drawings several now preferred embodiments are shown by way of illustration and not by way of limitation.

30 Fig. 1 is a diagrammatic view of the optical components of a light beam projecting range finder according to the invention.

35 Fig. 2 is a plan view of a light beam projecting range finder including an electric lamp according to the invention.

40 Fig. 3 is a diagrammatic view of the optical components of a modification of a light beam projecting range finder according to the invention, and

45 Figs. 4 and 5 are diagrammatic views of the images produced by a light beam projecting range finder according to the invention on an object, the images being shown in different positions of adjustment.

Referring now to the figures in detail, the optical system of the light beam projecting range finder, as shown in Fig. 1, comprises an electric lamp 10 having a filament 11. This lamp directs a beam of light toward a pivotal light deviating means 12 such as a fully silvered mirror or a prism which re-directs the beam of light toward an object the range of which is to be ascertained. The beam of light reflected by mirror 12 is passed through an image forming lens 13 so that an image of filament 11 is viewable on the object.

2,347,332

5

plane parallel to the optical axis between mirror 12 and pentaprism 15.

In order to facilitate the understanding of the invention, it be first assumed that pentaprism 15 be replaced by a reflector such as mirror 12. It will then be evident to a person skilled in the art that a variation of the filament position in axial direction, say a higher position of filament 11, will result in two light beams that are no longer parallel to each other when mirror 12 is placed in a position corresponding to the maximum measuring range of the range finder, thereby causing faulty indications throughout the entire measuring range of the range finder. Let it be now assumed that filament 11 be in a higher position in a range finder according to the invention in which light deviating means 15 consists of a means having constant 90° deviation characteristics. As a result of a higher position of filament 11 which is indicated in Fig. 1 by dashed lines, the light beam (shown in dashed lines), as reflected by mirror 12 will constitute an angle (α) with the light beam (shown in dashed-dotted lines), as reflected by mirror 12 when filament 11 is in its original position, (shown in full lines). The second light beam will also be reflected by prism 15 at an angle to the light beam as reflected by the pentaprism when filament 11 is in its original position. Due to the constant 90° deviation characteristics of prism 15, this angle will be always the same angle (α) as the angle between the light beams reflected by mirror 12. Consequently, parallelism between the light beams as projected by the light deviating means will be maintained in any higher position of filament 11. The same is true when the filament 11 is in any lower position, the only difference being that then the dotted light beams will be at the opposite side of the dashed-dotted light beams.

It will of course be understood that the corrective properties of pentaprism 15 are limited by the size of the pentaprism, but experience shows that variations in the filament position are rarely if ever beyond the corrective range of pentaprism 15.

Fig. 3 shows a modification in which pentaprism 15 is replaced by two stationary fully silvered mirrors 15' and 15'' arranged at a relatively acute angle to each other. These mirrors correspond to the reflecting surfaces of pentaprism 15 and hence constitute a light deviating means having constant 90° deviation characteristics. As a result, mirrors 15' and 15'' will always maintain parallelism between the reflected beams independently of a variation of the filament position, as previously described.

It should be understood that the invention is not and shall not be limited to the light deviating means, as herein disclosed but that other light deviating means may be provided having constant 90° deviation characteristics.

Fig. 4 shows an object 50 on which two images 11' and 11'' of filament 11 are viewable. These images are shown separated from each other, thereby indicating that the angle of mirror 12 does not correspond to the correct range of the object.

Fig. 5 shows the two images in a super-imposed position, thereby indicating correct adjustment of the angular position of mirror 12 which in turn will result in a correct focusing of the camera lens in case of a lens coupled range finder, as has been explained in connection with Fig. 2.

What is claimed as new and desired to be secured by Letters Patent is:

1. A light beam projecting range finder com-

6

prising a light source, a first light deviating means receiving light from said light source and directing a beam of light toward an object, and a second light deviating means receiving light from said light source and directing a second beam of light toward the object, said light deviating means being constructed to be movable relative to each other for varying the angular relationship of said light beams, one of the light deviating means having constant 90° deviation characteristics.

2. A light beam projecting range finder comprising a light source, a first image forming lens means receiving light from said light source, a first light deviating means receiving light from said first lens means and directing a beam of light toward an object, a second light deviating means receiving light from said light source, and a second image forming lens receiving light from said second light deviating means and directing a second beam of light toward said object, said light deviating means being constructed to be movable relative to each other for varying the angular relationship between said light beams, one of the light deviating means having constant 90° deviation characteristics.

3. A light beam projecting range finder comprising a light source, a first image forming lens means receiving light from said light source, a first light deviating means receiving light from said first lens means and directing a beam of light toward an object, a second light deviating means receiving light from said light source, and a second image forming lens receiving light from said second light deviating means and directing a second beam of light toward said object, one of said light deviating means being pivotal for varying the angular relationship between said light beams, the other light deviating means having constant 90° deviation characteristics.

4. A light beam projecting range finder as described in claim 2, wherein the light deviating means having constant 90° deviation characteristics comprises a pentaprism.

5. A light beam projecting range finder as described in claim 2, wherein the light deviating means having 90° deviation characteristics comprises a pair of mirrors mounted at a relatively acute angle to each other.

6. In a light beam projecting range finder including a light source, in combination a pair of images forming lenses and reflecting means for directing a pair of images of the light source on an object whose range is to be determined, one of said reflecting means being a movable mirror to effect coincidence of the images on the said object, the other reflecting means comprising a constant 90° deviation prism, whereby a slight displacement of the light source relative to the optical axis of the range finder will result in displacement of the images which are equal and in the same direction.

7. In a light beam projecting range finder, in combination an exchangeably mounted electric incandescent lamp having a filament, an image forming lens and a reflecting means mounted on either side of the lamp in an optical relationship with the lamp filament for directing a pair of images of the filament to an object whose range is to be determined, one of said reflecting means being a movable reflector to effect coincidence of the images on the said object, the other reflecting means having constant 90° deviation characteristics, whereby a slight displacement of the filament position relative to the optical axis between the reflecting means will result

2,547,232

7

in displacements of the said images that are equal and in the same direction.

MORRIS SCHWARTZ.
WILLIAM CASTEDELLO.

REFERENCES CITED

The following references are of record in the file of this patent:

8

UNITED STATES PATENTS

| Number | Name | Date |
|-----------|----------------------|--------------|
| 889,625 | Konig et al. | June 2, 1908 |
| 1,062,166 | Konig | May 20, 1913 |
| 1,489,838 | Kohler | Apr. 8, 1924 |
| 2,379,698 | Fischer | July 3, 1945 |
| 2,401,708 | Mihalyi | June 4, 1946 |
| 2,403,308 | Schwartz et al. | July 2, 1946 |

Feb. 8, 1955

M. SCHWARTZ ET AL
RANGE FINDING UNIT, INCLUDING A VIEWING RANGE
FINDER AND A LIGHT BEAM PROJECTING RANGE
FINDER FOR PHOTOGRAPHIC PURPOSES

2,701,500

Filed March 9, 1951

2 Sheets-Sheet 1

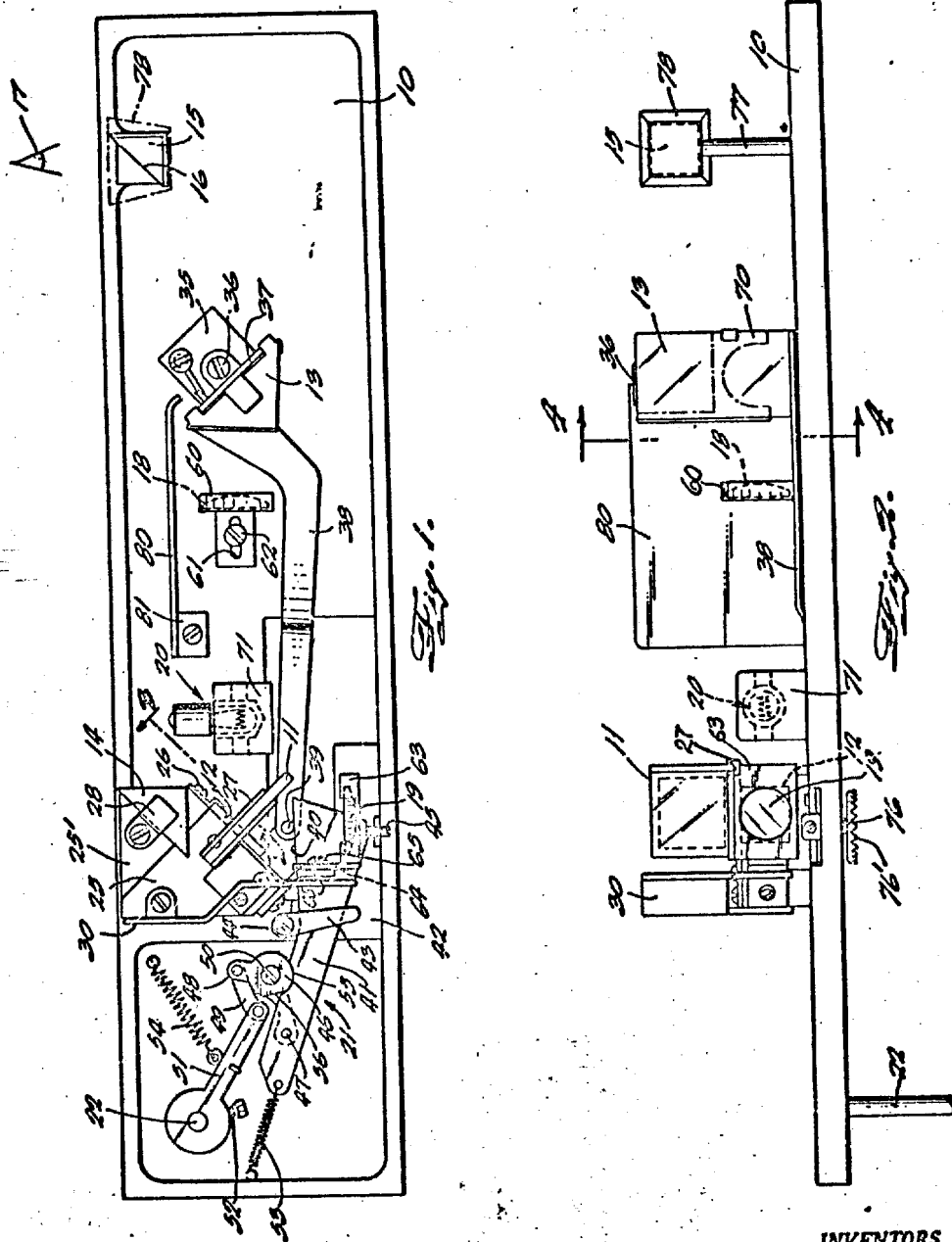

INVENTORS
MORRIS SCHWARTZ
WILLIAM CASTEDELLO
BY
Andrew L. Harris
ATTORNEY

Feb. 8, 1955

M. SCHWARTZ ET AL
RANGE FINDING UNIT, INCLUDING A VIEWING RANGE
FINDER AND A LIGHT BEAM PROJECTING RANGE
FINDER FOR PHOTOGRAPHIC PURPOSES

2,701,500

Filed March 9, 1951

2 Sheets-Sheet 2

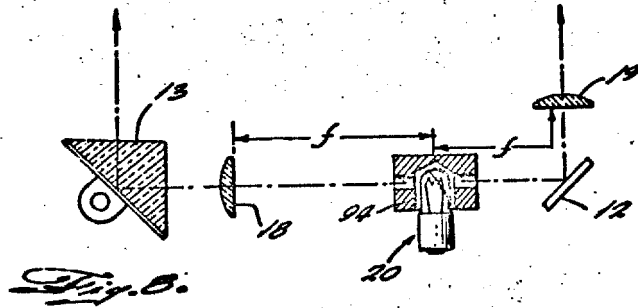
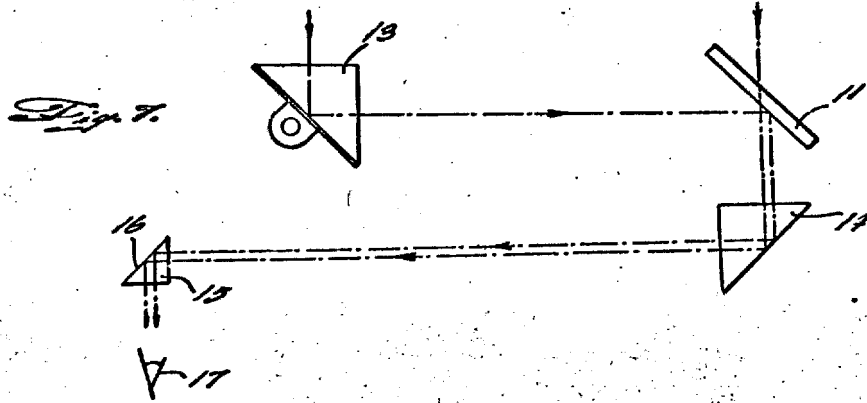
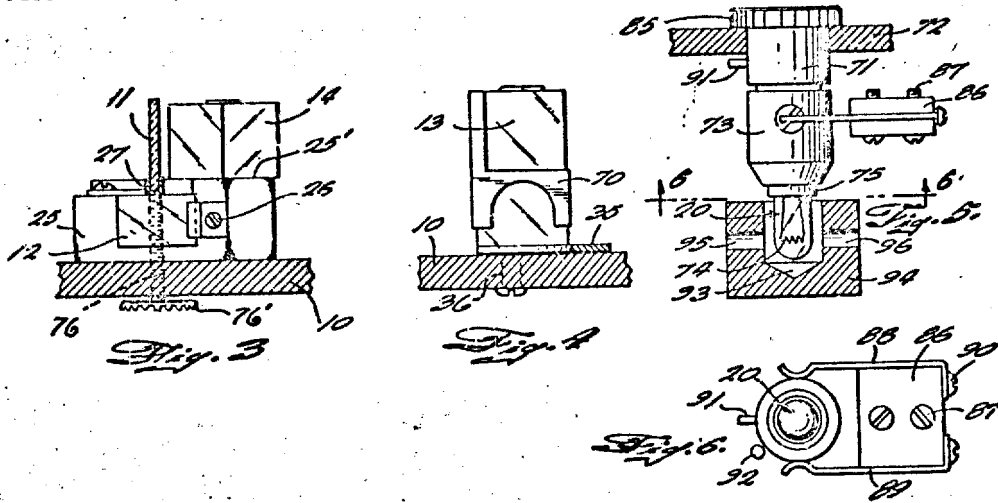

INVENTORS
MORRIS SCHWARTZ
WILLIAM CASTEDELLO
BY
Andrick E. Haize
ATTORNEY

United States Patent Office

2,701,500

Patented Feb. 8, 1955

1

2,701,500

RANGE FINDING UNIT, INCLUDING A VIEWING RANGE FINDER AND A LIGHT BEAM PROJECTING RANGE FINDER FOR PHOTOGRAPHIC PURPOSES

Morris Schwartz and William Castedello, Plainville, Conn., assignors to The Katart Company Inc., Plainville, Conn.

Application March 9, 1951, Serial No. 214,736

5 Claims. (Cl. 88-2.4)

This invention relates to a viewing range finder and a light beam projecting range finder unit for photographic purposes, particularly to a unit of this type designed for mounting within the casing of a photographic camera and controlled by the focusing movement of the camera lens.

It will be evident, that the space available in the casing of a camera, even of a comparatively large camera such as a so-called press camera, is rather limited. As a result, it is difficult from a manufacturing view point to find room for all the necessary components of the unit without reducing the individual components to a size which makes the same too delicate and interferes with a satisfactory range finding operation.

One of the objects of the present invention is to provide a combination unit of the general type, above referred to, which is so compact in design that it can be conveniently fitted in the space generally available in a camera casing without sacrificing the accuracy and reliability of the range finding operation and without reducing the sharpness of vision through the system.

Another object of the invention is to provide a novel and improved combination unit of the general type, above referred to, which is simple in design and requires comparatively few individual components. These advantages are attained by structurally combining some of the optical components of the viewing range finder and the light beam projecting range finder.

Another more specific object of the invention, allied with the preceding one, is to reduce the total space occupied by the two range finders by arranging some of the individual components one above the other and by a novel arrangement of the image forming lenses of the light beam projecting range finder.

Other and further objects, features and advantages of the invention will be pointed out hereinafter and set forth in the appended claims forming part of the application.

In the accompanying drawing a now preferred embodiment of the invention is shown by way of illustration and not by way of limitation.

In the drawing:

Fig. 1 is a plan view of a lens coupled range finding combination unit according to the invention.

Fig. 2 is an elevational side view of Fig. 1.

Fig. 3 is a section taken on line 3-3 of Fig. 1.

Fig. 4 is a section taken on line 4-4 of Fig. 2.

Fig. 5 is a section of the lamp holder on an enlarged scale.

Fig. 6 is a plan view of Fig. 5 seen along line 6-6 of Fig. 5.

Fig. 7 is a diagram of the optical system of the viewing range finder, and

Fig. 8 is a diagram of the light beam projecting range finder of the unit.

Referring first to Figs. 1 to 6, the entire range finding unit is mounted upon a base plate 10 which should be visualized as a partition wall in a camera casing. The stationary reflector of the viewing range finder is designated by 11 and the stationary reflector of the light beam projecting range finder is designated by 12. Reflector 11 is a semi-transparent mirror and partially coated for this purpose. Mirror 11 acts as a beam splitter in a conventional manner. Reflector 12 is a solidly silvered mirror. The pivotal reflectors of the two range finders are formed by a common reflector 13 shown as a prism.

The optical components of the viewing range finder further comprise a stationary reflector 14 shown as a

2

prism which reflects images viewable on the beam splitter to a stationary reflector 15 having a reflecting surface 16. The position of the eye of the observer is indicated at 17.

The light beam projecting range finder comprises, in addition to the aforementioned components, an image forming lens 18 disposed in the optical center axis between mirror 12 and prism 13 and an image forming lens 19 disposed between mirror 11 and an exterior object, the range of which is to be determined. The last mentioned range finder further includes a source of light shown as an incandescent light bulb, generally designated by 20.

The common prism 13 is pivoted by moving means, generally designated by 21. These moving means are controlled in a conventional manner by the focusing movement of the camera lens and should be visualized as being coupled with the lens carrier by means of a shaft 22 which is rotated by a displacement of the lens carrier on the camera bed. It is believed that the coupling between shaft 22 and the lens camera is not essential for the understanding of the invention and it is, therefore, not shown in detail.

Referring now to Figs. 7 and 8, Fig. 7 shows a diagram of the optical system of the viewing range finder and Fig. 8 of the light beam projecting range finder.

As will be apparent from Fig. 7, a light beam reaching beam splitter 11 from an exterior object to be observed will pass through the beam splitter and is reflected by prisms 14 and 15 to the eye 17 of the observer. A second beam from the object will be reflected by pivotal prism 13 to beam splitter 11, then by the beam splitter to prism 14, and finally by prism 14 to prism 15. As a result, an observer can view two images of the object on the reflecting surface 16 of prism 15, the relative position of the two images being controlled by the angular position of prism 13 which, in turn, is controlled by the focusing movement of the lens in a manner well understood in the art.

According to Fig. 8, a light beam will be projected toward the object by stationary mirror 12 through lens 19 and a second light beam through lens 18 by pivotal prism 13. As will be obvious, due to the image forming lenses 18 and 19, the observer will see two images of the filament of lamp 20 on the object, the relative position of said images being again controlled by the angular position of prism 13.

Reverting again to Figs. 1 and 2 and also referring to the companion Figs. 3, 4, 5 and 6, the structural features of the range finding unit will now be described in detail.

As can best be seen on Fig. 1 a bracket or block 25 is fixedly secured to base plate 10. This block has a slanted side wall to which is secured mirror 12 by any suitable means such as screws 26. The top of block 25 is flat and supports the mountings of beam splitter 11 and prism 14. Beam splitter 11 and prism 14 can be mounted in any suitable manner, a frame 27 and a bracket 28 being indicated by way of illustration. It is essential to note in this connection that mirror 12 and beam splitter 11 are mounted substantially one above the other, mirror 12 being disposed at the lower level relative to the base plate 10. Prism 14 is disposed in the upper level and in substantially the same horizontal plane with beam splitter 11.

Block 25 may further support a shield 30 which serves to prevent stray light to enter the section of the compartment to the left of the optical systems of the range finders (as seen in Figs. 1 and 2) which section may serve to house for instance the optical system of a view finder.

Prism 13, which of course could be replaced by a mirror, is pivotally mounted on the base plate by means of a bracket 35 and pivots about a shaft 36. As can best be seen on Fig. 2, prism 13 is elongated to extend through the level of mirror 12 to the level of beam splitter 11. While it is preferable and also shown to make prism 13 out of one piece, it will be apparent that this prism could also be made of two sections, one on top of the other. Prism 13 is secured to a suitable mounting 37 which pivots together with the prism and is attached to or integral with a lever 38 the free end of which supports a pin 39 coacting with a cam or wedge surface 40 of a lever 41. This lever is slidably guided between a rib 42 of base plate 10 and a finger 43 secured to

2,701,500

3

rib 42 for instance by a screw 44. Lever 41 is further guided by an adjustment screw 45 engaging an edge of lever 41. It will be apparent that adjustment of screw 45 will vary the path of engagement between pin 39 and wedge surface 40 and, thereby, also the ratio of transmission between the rotation of shaft 22 and the angular position of prism 13. One arm of a two-arm lever 46 is pivoted to lever 41 by a pivot pin 47 and the other arm of this lever is pivoted by a pivot pin 48 to an arm 49. Lever 46 is pivotal about a pivot 50. Arm 49 is pivoted to an arm 51 which in turn is fixedly secured to shaft 22, for instance by means of a screw 52. Springs 53 and 54, secured on one end to base plate 10 and on the other end to arm 51 and lever 41 respectively, load the entire system so that wedge surface 40 is always biased against pin 39 and a notch 55 is biased against a limiting edge 56 of lever 46.

The entire hereinbefore described system of moving means 21 is mounted in the lower level or plane or closely adjacent to base plate 10. As will be apparent, a certain angular rotation of shaft 22 will result in a corresponding pivotal movement of prism 13, thereby jointly varying the angular position of the pivotal reflecting surfaces of both the range finders.

Image forming lens 18 is secured to base plate 10 by means of a mounting 60 which can be adjusted in the direction of the optical axis of the lens by means of an elongated slot 61 and a screw 62. Similarly, lens 19 is secured to block 25 by means of a mounting frame 63 and can be adjusted in the direction of its optical axis by means of an elongated slot 64 and a screw 65 engaging a bracket 66 secured to block 25.

A mask 70 on the lower half of prism 13 limits the effective reflecting surface of this prism in accordance with the diameter of lens 18.

Lamp 20 is inserted in a lamp holder of suitable design. This lamp holder is shown as comprising a metal sleeve 71 which is rotatably fitted in a wall 72 which may be visualized as part of the camera casing. Sleeve 71 supports an insulation sleeve 73 in which is fitted a metal sleeve 75 which serves to receive the base of lamp 20. The terminals of the lamp are connected in a conventional manner to a source of current, usually a battery disposed within the camera casing. The entire lamp holder can be rotated by means of a knurled head 85 accessible from the outside of the camera. To secure the holder in a selected rotary position an insulation block 86 is secured by screws 87 to a bracket extending from base plate 10 (not shown). The insulation block supports two springs 88 and 89 secured to block 86 by screws 90. These springs engage frictionally sleeve 73 thereby holding the lamp holder in position. A pin 91 extending from sleeve 71 and engageable with a stationary stop 92 secured to base plate 10 or part of the camera casing serves to limit the rotational movement of the lamp holder.

The globe of the lamp extends into an axial bore 93 of a block 94 made of opaque material and secured to base plate 10. Block 94 further includes two channels or bores 95 and 96 extending from the central bore 93 and positioned in alignment with the lamp filament 74 and the optical center axis between reflectors 11 and 13. Lamp 20 is of the type having a filament 74 in form of a substantially cylindrical coil and is so inserted in the lamp holder that the long axis of the filament coil is parallel to the aforementioned optical axis. As a result, the two images of the lamp filament which are projected by the light beams of the range finder appear as circles which can be conveniently and accurately placed in a superimposed position.

As previously mentioned, frame 27 of the beam splitter 11 of the viewing range finder is mounted on the top of block 25. The position of the beam splitter can be adjusted by means of a screw 76. Rotation of this screw by means of a crown wheel 76' causes the beam splitter to be tilted slightly in its own plane for purposes of adjustment.

The reflecting prism 14 of the viewing range finder is also mounted on block 25 or more specifically on a raised portion 25' thereof so that prism 14 is at the correct level relative to the beam splitter, as can best be seen on Fig. 3. The viewing prism 15 of the viewing range finder is mounted on the same level as prism 14 by means of a post 77 secured to base plate 10. A mask or screen 78 may be provided to prevent stray light from lamp

4

20 to reach prism 15 and to disturb thereby the observer when viewing the images on the prism. The optical systems of the range finders may further be shielded against stray light by a shield 80 secured to base plate 10 by an ear 81.

As will appear from the previous description, the optical systems of the two range finders are disposed in two different planes parallel one to the other. The only movable optical components of the two finders, namely the pivotal reflector, are combined in the single element 13 so that the same moving means 21 can be used for the pivotal reflectors of both the finders. Furthermore, one of the image forming lenses is disposed between the respective reflectors. Finally, the provision of the reflectors 14 and 15 permits to view the two images of the viewing range finder in a position very closely adjacent to the position normally occupied by the eye of the observer when the observer uses the view finder of a camera of the type here in question. This view finder, as previously mentioned, may be visualized as being disposed in the compartment to the left of shield 30. As a result, only a slight shift of the eyeball of the observer is necessary to switch from the viewing operation to the range finding operation.

The result of the aforescribed structural arrangement of all the optical and mechanical components of the range finders is a very compact design which can be conveniently mounted within the available space of a camera casing without requiring an undue reduction of the size of the individual components.

While the invention has been described in detail with respect to a certain now preferred example and embodiment of the invention it will be understood by those skilled in the art after understanding the invention, that various changes and modifications may be made without departing from the spirit and scope of the invention, and it is intended, therefore, to cover all such changes and modifications in the appended claims.

What is claimed as new and desired to be secured by Letters Patent is:

1. A photographic range finding unit comprising a viewing range finder and a light beam projecting range finder, the said viewing range finder including a semi-transparent stationary reflector through which an image of an object exterior to the said range finder is viewable, a pivotal reflector disposed in optical and spacial alignment with the stationary reflector so as to reflect a second image of the exterior object to the stationary reflector, and reflecting and viewing means optically associated with the stationary reflector for viewing the said two images; the said light beam projecting range finder including a stationary reflector, a pivotal reflector, a holder for a source of light disposed between the two reflectors of the light beam projecting range finder, the said stationary reflector, the said pivotal reflector and the said holder of the light beam projecting range finder being disposed in optical alignment an image forming lens between said light holder and the respective pivotal reflector in optical alignment therewith, and a second image forming lens between the respective stationary reflector and said exterior object in optical alignment therewith, thereby causing each of the two reflectors of the light beam projecting range finder to reflect a light beam emanating from a source of light in said holder toward the said exterior object, respective reflectors of the two range finders being disposed one above the other substantially in alignment one with the other, the said pivotal reflectors of the range finders being formed by a single pivotally mounted reflecting member including a light deviating surface having a portion in optical and spacial alignment with the stationary reflector of one of the range finders for the purpose aforesaid and a second portion in optical and spacial alignment with the stationary reflector of the other range finder for the purpose aforesaid, and moving means coupled with said pivotal member for varying the angular position of the said pivotal reflectors.

2. A range finding unit as defined in claim 1, wherein the aforementioned components of one of said range finders are disposed substantially in one layer and the aforementioned components of the other range finder substantially in a second layer generally parallel to and above the first layer, and wherein said light deviating surface of the pivotal reflecting member extends through both said layers.

2,701,500

5

3. A range finding unit as defined in claim 2, wherein the said pivotal reflecting member is a single prism elongated to extend through both said layers having their reflecting surfaces in the same plane.

4. A range finding unit as defined in claim 1, in combination with a base plate on which said pivotal reflecting member, a bracket having a side wall and a top wall, said image forming lenses, said moving means, said reflecting and viewing means, and said light holder are mounted, said bracket supporting on said side wall the stationary deflector for the light beam projecting range finder and on its top wall the stationary reflector for the viewing range finder.

5. A range finding unit comprising a base plate, a viewing range finder and a light beam projecting range finder mounted on said base plate, the said viewing range finder including a semi-transparent stationary reflector through which an image of an object exterior to the said range finder is viewable, a pivotal reflector disposed in optical and spacial alignment with the stationary reflector so as to reflect a second image of the exterior object to the stationary reflector, and reflecting and viewing means optically associated with the stationary reflector for viewing the said two images; the said light beam projecting range finder including a stationary reflector, a pivotal reflector, a holder for a source of light disposed between the two reflectors of the light beam projecting range finder, the said stationary reflector, the said pivotal reflector and the said holder of the light beam projecting range finder being disposed in optical alignment, an image forming lens between said light holder and the respective pivotal reflector in optical alignment therewith, and a second image forming lens between the respective stationary reflector and said exterior object, thereby causing each of the two reflectors of the light beam projecting

6

range finder to reflect a light beam emanating from a source of light in said holder toward the said exterior object, the reflectors and the viewing means of the viewing range finder being disposed substantially in one layer parallel to the base plate, and the reflectors, the lenses and the light holder of the light beam projecting range finder being disposed in a second layer situated between the said first layer and the base plate parallel to the first layer and the plate, respective reflectors of the two range finders being disposed one above the other substantially in transverse alignment relative to said layers, the said pivotal reflectors of the range finders being formed by a single pivotally mounted reflecting member including a light deviating surface having a portion in optical alignment with the stationary reflector of one of the range finders and a second portion in optical alignment with the stationary reflector of the other range finder, both said portions being in one plane, and moving means coupled with said pivotal member for varying the angular position of the said pivotal reflectors, the said moving means being disposed substantially in the second parallel layer.

References Cited in the file of this patent

UNITED STATES PATENTS

| | | |
|-----------|-----------------|---------------|
| 1,489,838 | Kohler | Apr. 8, 1924 |
| 2,101,543 | Henkel | Dec. 7, 1937 |
| 2,151,124 | Leitz | Mar. 21, 1939 |
| 2,376,982 | Schwartz et al. | May 29, 1945 |
| 2,379,698 | Fischer | July 3, 1945 |
| 2,397,160 | Schwartz et al. | Mar. 26, 1946 |
| 2,403,308 | Schwartz et al. | July 2, 1946 |
| 2,547,232 | Schwartz et al. | Apr. 3, 1951 |

Oct. 10, 1961

D. S. GREY

3,003,407

COMBINED RANGE FINDER AND VIEW FINDER

Filed Oct. 8, 1956

4 Sheets-Sheet 1

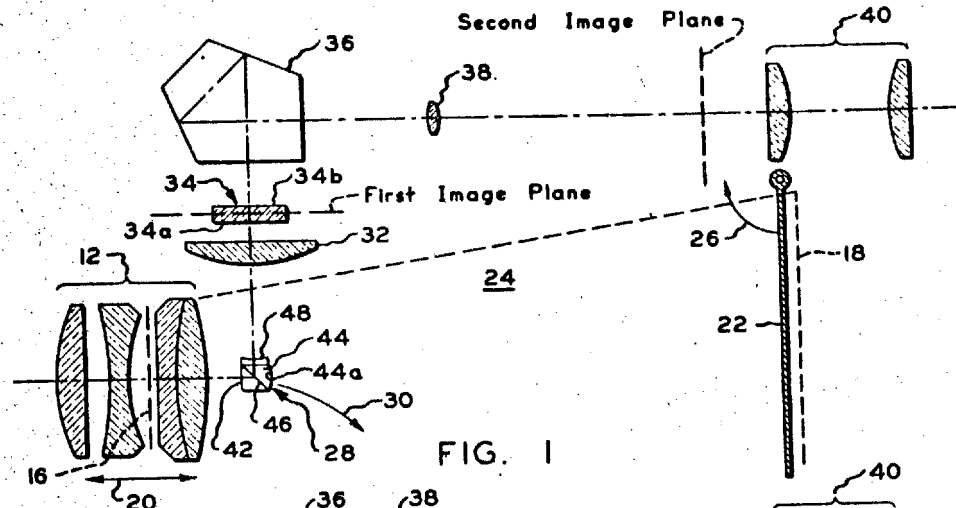

FIG. 1

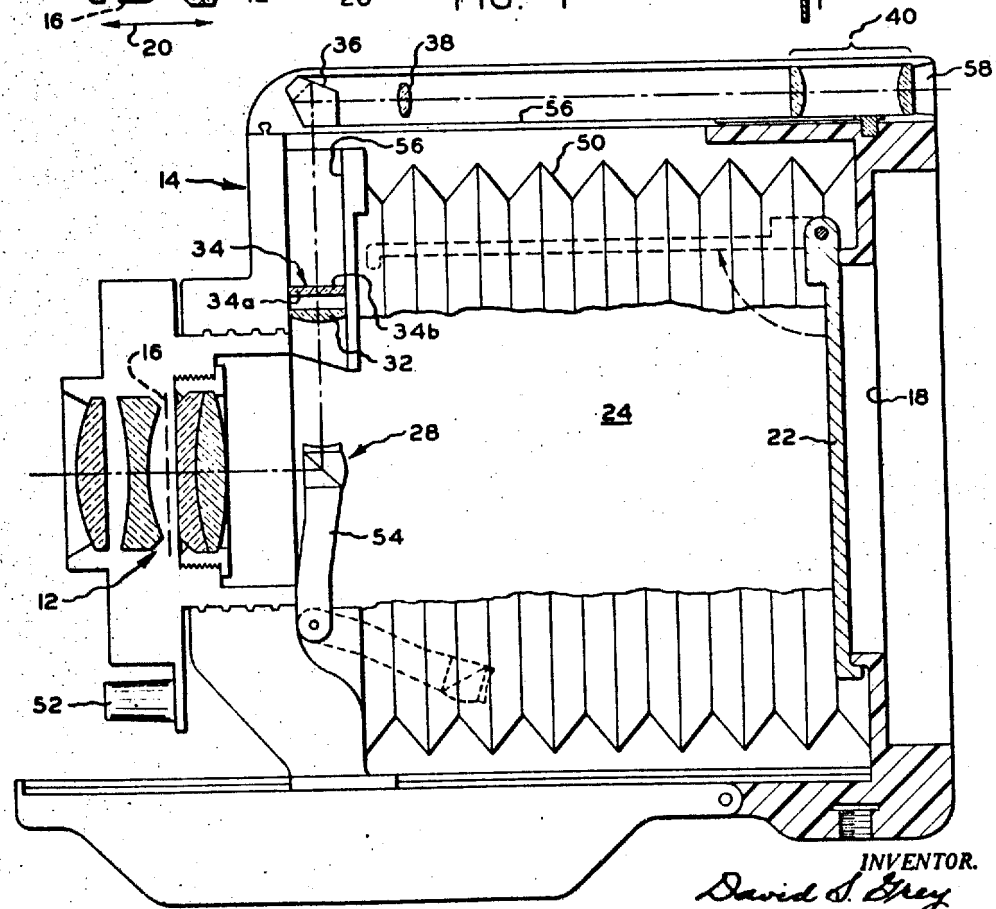

FIG. 2

INVENTOR.
David S. Grey
BY
Crown and Mikulka
ATTORNEYS

Oct. 10, 1961

D. S. GREY

3,003,407

COMBINED RANGE FINDER AND VIEW FINDER

Filed Oct. 8, 1956

4 Sheets-Sheet 2

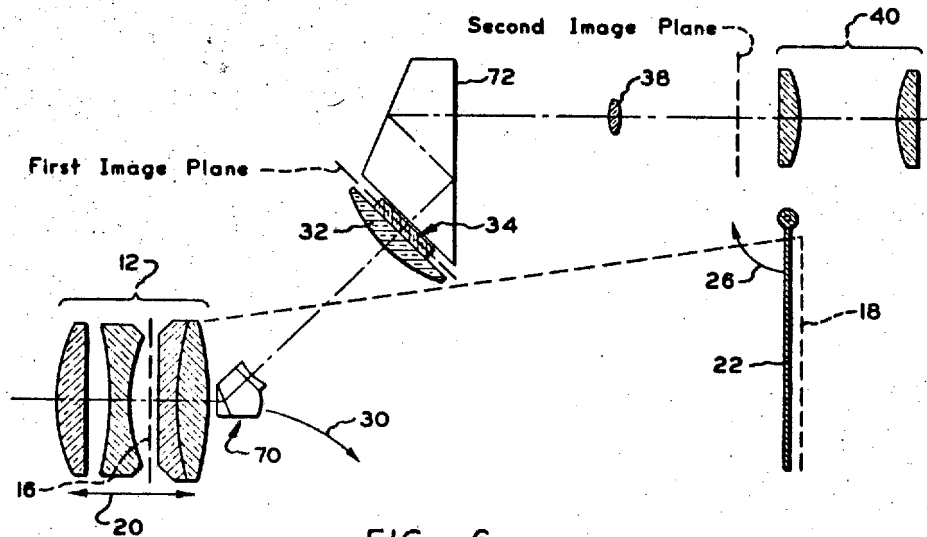
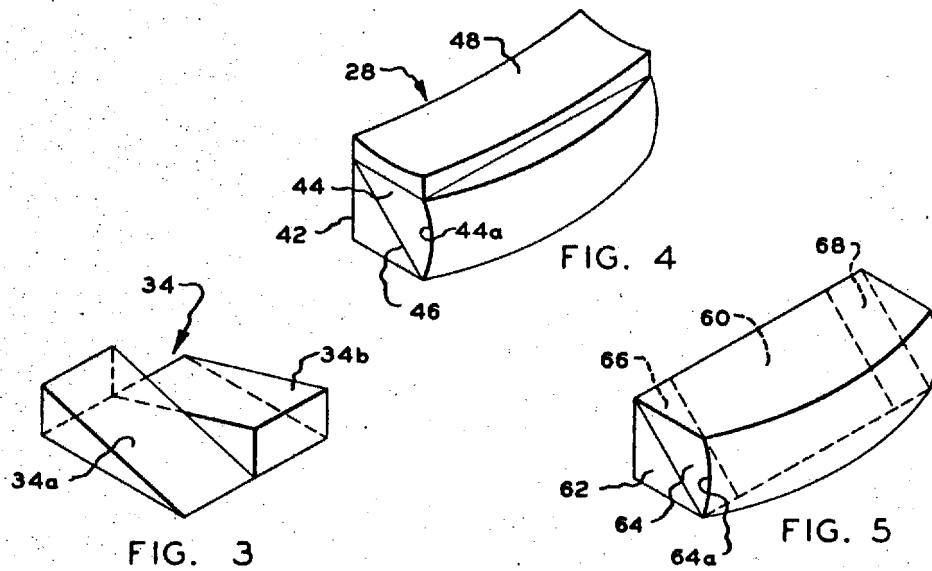

INVENTOR.
David S. Grey
BY
Brown and McQuinn
ATTORNEYS

Oct. 10, 1961

D. S. GREY

3,003,407

COMBINED RANGE FINDER AND VIEW FINDER

Filed Oct. 8, 1956

4 Sheets-Sheet 3

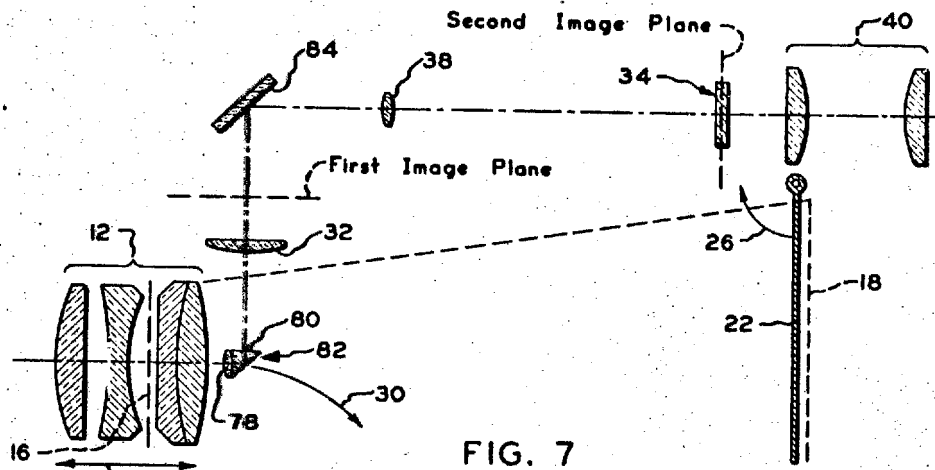

FIG. 7

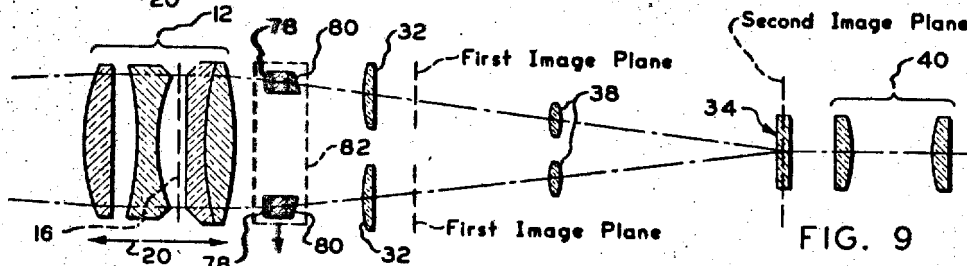

FIG. 9

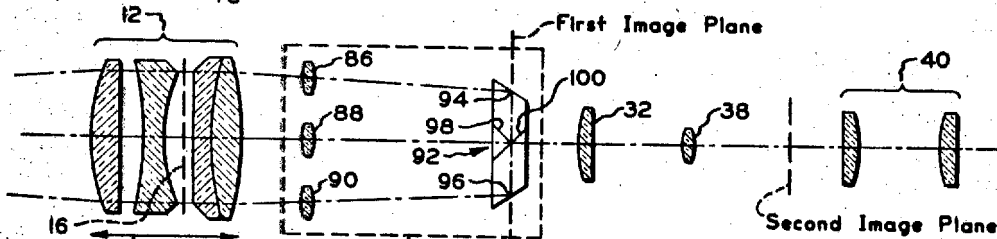

FIG. 10

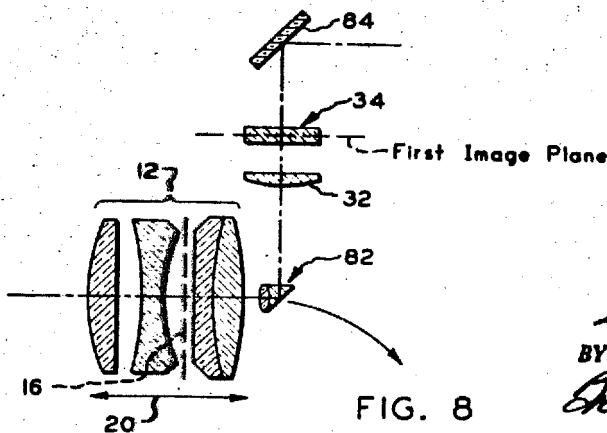

FIG. 8

INVENTOR.
David S. Grey
 BY
Chown and Melitta
 ATTORNEYS

Oct. 10, 1961

D. S. GREY

3,003,407

COMBINED RANGE FINDER AND VIEW FINDER

Filed Oct. 8, 1956

4 Sheets-Sheet 4

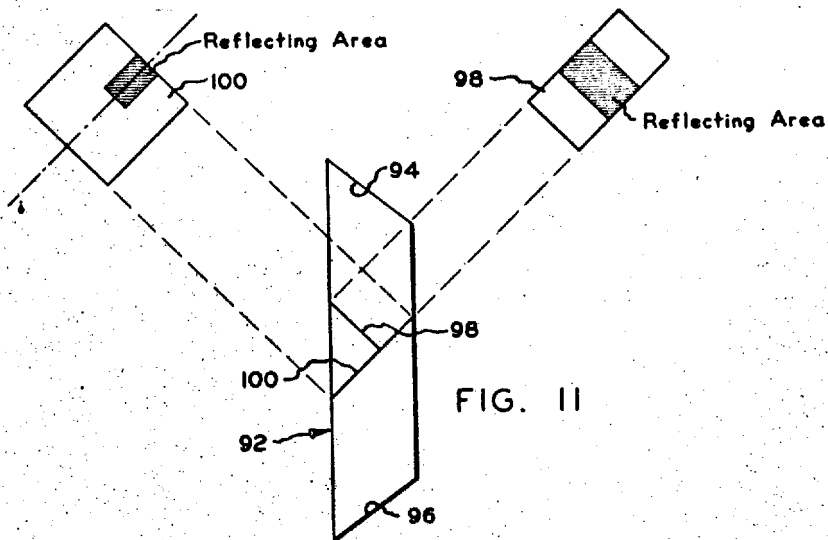

FIG. 11

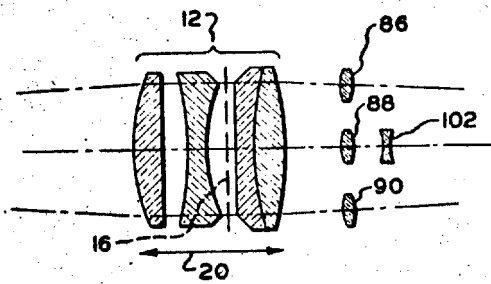

FIG. 12

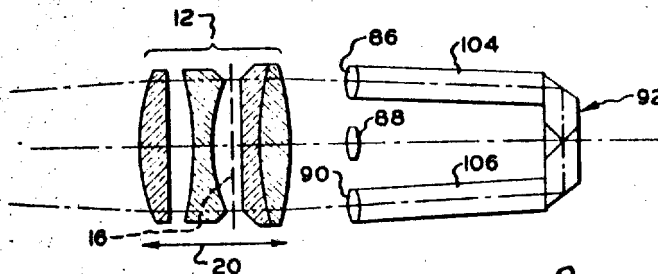

FIG. 13

INVENTOR.
David S. Grey
BY *Brown and McKelley*
ATTORNEYS

1

3,003,407

COMBINED RANGE FINDER AND VIEW FINDER
David S. Grey, Weston, Mass., assignor to Polaroid Corporation, Cambridge, Mass., a corporation of Delaware
Filed Oct. 8, 1956, Ser. No. 614,716
15 Claims. (Cl. 95-44)

The present invention relates to a range finder and a view finder for use in a photographic camera and more particularly to a combined range finder and view finder which employs the objective lens of the camera for ranging and view finding, in addition to its imaging function relative to the photographic exposure.

Various advantages are known to accrue to the employment of the camera objective in view finding systems, said systems being generally either of a reflex type or one in which viewing occurs along an eye-level axis which is an optical image of the axis of the objective, either coincident with or laterally displaced with respect to that of the objective. One principal benefit identified with this type of view finder is avoidance of the need of correcting for parallax, there being provided for viewing purposes an accurate image of the photographic subject. Furthermore, where the entrance pupil of the range and view finder system is identified with the camera objective rather than with a separate finder objective the same overlap of foreground with background objects occurs in said system as in the photographic image. In addition, a positive and accurate framing of the field, irrespective of frontal attachments or of the focal setting of the camera objective is achieved.

Use has been made of the camera objective, or of a special objective, in a so-called split-field range finding system combined with a view finding system wherein the central area of the objective is employed for imaging the view finder field and marginal areas of the objective are used for imaging the range finder field. However, systems of the last-mentioned type have, it is believed, only found application relative to small cameras, namely, cameras of the type employing 35 mm. film, said systems being entirely unsuitable for incorporation with larger cameras such as those providing an image diagonal greater than approximately three inches.

In another known finder system, the image formed by the camera objective is deflected by a mirror to a position such that it can be viewed by a magnifier, either simple or compound. In a camera which employs a small image area, it is feasible to follow this procedure but if the image area has a diagonal dimension larger than approximately three inches, the necessity for providing an image to be viewed by the magnifier, together with the requirement for a magnifier so constructed as to collect light from this image necessitates an unwieldy, bulky and costly system, especially if such a system is of an eye-level type. The same considerations also apply, perhaps even more strongly, to other known systems which employ an auxiliary finder lens of the same focal length as the camera objective instead of said objective. The present invention is concerned with the provision of a compact, relatively simple and moderately priced combined range and view finder system, utilizing the camera objective and adapted to incorporation with cameras of the larger type, hereinbefore mentioned.

An important feature of the present invention is the

2

construction in which an auxiliary or complementary positive lens or its optical equivalent is inserted behind the camera objective which, in combination with said camera objective, forms, in effect, a lens of short focal length. Hence, the angular field of the camera objective is imaged within a small area. There are two principal variations of this arrangement as follows:

In one arrangement, a single auxiliary positive lens or objective is employed, the positive lens being positioned behind the camera objective and dimensioned to cover an area which is generally coextensive with a strip-like area extending substantially across the objective aperture thus permitting the use of light which passes through the edges or marginal areas of said aperture for range finding purposes.

Another arrangement employs two or more auxiliary objective lenses having individual optical axes and being behind the camera objective, the separate axes being subsequently combined by suitable light-deviating means, such as optical wedges or reflecting means, so that they have substantially coincident image planes. The separation between the apertures of the auxiliary objectives permits acceptance of light from marginal portions of the camera objective and, accordingly, permits accurate ranging.

One object of the invention is to provide a novel and efficient combined split-field range finder and view finder system for a larger type camera in which the camera objective is employed as a component of the system and in which focusing of the photographic image and of the ranging and view finder images is obtained simultaneously through movement of the objective along its axis to a correct position.

Another object is to provide and arrange a plurality of reflecting and refracting optical components of given characteristics in combination with a camera objective of relatively large image diagonal so that light rays passing through the central area of the objective are used in forming view finder image portions and light rays passing through marginal areas of the objective are employed in forming ranging image portions.

A further object is to provide a range and view finder system in a form wherein light-deviating and imaging components may readily be moved into, operated within, and withdrawn from the area defined by the angle of view of the objective which is used for making the photographic exposure.

Other objects are to provide systems of the character described employing novel combinations of optical components which result in improved imaging accuracy, desired image magnification and reduction, contrast between ranging and view finding image areas, and correction for spherical and chromatic aberration; to provide an eye-level range and view finding system wherein erect images having unreversed left and right image portions are produced and can be seen through a single viewing aperture; and to provide a system in which photosensitive materials positioned in the focal plane of the camera are safeguarded from unwanted actinic light during operation of the ranging and view finding components.

Other objects of the invention will in part be obvious and will in part appear hereinafter.

The invention accordingly comprises the product

3,003,407

3

possessing the features, properties and the relation of components which are exemplified in the following detailed disclosure, and the scope of the application of which will be indicated in the claims.

For a fuller understanding of the nature and objects of the invention, reference should be had to the following detailed description taken in connection with the accompanying drawings wherein:

FIGURE 1 is a side-elevational view, in section, illustrating diagrammatically a combined range and view finder optical system of the present invention;

FIG. 2 is a diagrammatic, side-elevational view, partly in section, of a camera showing incorporation of the system of FIG. 1 therein;

FIG. 3 is a diagrammatic view, in perspective, of the optical wedge means of FIG. 1;

FIG. 4 is a diagrammatic view, in perspective, of a light-deviating and image-forming component of FIG. 1;

FIG. 5 is a diagrammatic view, in perspective, of a modification of the optical component of FIG. 4;

FIG. 6 is a diagrammatic side-elevational view, in section, showing a modification of the combined range and view finder optical system of FIG. 1;

FIG. 7 is a view, similar to that of FIG. 6, of another combined range and view finder optical system of the invention;

FIG. 8 is a diagrammatic side-elevational view of a modified portion of the optical system of FIG. 7;

FIG. 9 is a diagrammatic, top plan view, partly in section, of the system of FIG. 7;

FIG. 10 is a diagrammatic, top plan view, in section, of another combined range and view finder optical system of the invention;

FIG. 11 is a diagrammatic view of the composite light-deviating and image-forming element of FIG. 10 showing surface areas in elevation;

FIG. 12 is a diagrammatic, top plan view of a modification of a portion of the system of FIG. 10; and

FIG. 13 is a diagrammatic top plan view of another modification of a portion of the system of FIG. 10.

Referring to FIG. 1, a combined range and view finding system of the invention is shown which incorporates the picture "taking" objective lens 12 of a camera 14, the camera being shown more fully in FIG. 2. The objective lens 12, or a component thereof, is movable toward and away from focal plane 18 by conventional means, not shown, as indicated by the double-headed arrow 20. Camera 14 has, for example, a between-the-lens shutter and an iris diaphragm, not shown, positioned at location line 16, and a focal plane 18, the latter being the image plane of objective 12 which is used for positioning and photographically exposing a photosensitive film. It is to be assumed that camera 14 is of a type larger than a so-called "miniature" camera. A light lock 22 is mounted for positioning within and withdrawal from the area 24 defined by the angle of view of objective 12. The light lock, at the closed position shown, serves to shield from actinic light a film, not shown, which would normally be positioned for exposure at plane 18 when the range and view finding system is being used preparatory to said exposure. The light lock is pivoted away from its light intercepting position when a photographic exposure is about to be made, as indicated by arrow 26. Other components of the combined range and view finding system comprise a composite light-deviating and image-forming element 28, movable, as indicated by arrow 30, in and out of area 24, as for example, by pivotal or slidable mounting means, such as the pivotal means shown in FIG. 2, a field lens 32, ranging wedge means 34 composed of wedges 34a and 34b shown in detail in FIG. 3, prism 36, relay lens 38 and eyepiece 40. Composite element 28 is composed of prism components 42 and 44 bonded together and having an intervening, semi-transparent, reflecting surface 46. Prism component 44

4

is provided with an image-forming, concave, spherical, specularly-reflecting surface 44a. A negative lens element 48 is bonded to the upper planar surface of component 44, as shown in greater detail in FIG. 4.

Operation of the system is substantially as follows. Assuming light lock 22 to be closed and composite element 28 to be positioned as shown, the iris diaphragm to be open to its maximum diameter and the shutter to be open, light from the field of view which includes an object to be ranged is admitted to the combined range and view finding system. The image-forming light rays from the objective and incident upon composite element 28 are transmitted by prism component 42, semi-reflecting surface 46 and component 44 to concave reflecting surface 44a, whence they are returned through component 44 to surface 46, are reflected upwardly therefrom through lens component 48 and pass through field lens 32 to the first image plane. The objective 12, or a component thereof, is moved axially to establish, in conjunction with concave image-forming mirror 44a operating as an auxiliary or complementary objective, correct focus relative to the first image plane. The concave mirror 44a in conjunction with negative lens 48 provides correction for spherical and chromatic aberration, said correction being of importance if ranging is to be accurate.

The system has an exit pupil defined, for example, by the image of the relay lens 38, and three distinct entrance pupils each of which pertains to a separate portion of the field of view. The principal entrance pupil lies at or near the center of composite element 28 and is conjugate to said exit pupil for light from the field of view which passes outside the area defined by the deviating wedges 34a and 34b which are used for ranging. The two other entrance pupils located at each side of the central entrance pupil, are conjugate to the exit pupil for light which passes through the respective ranging wedges.

The deviating wedges 34a and 34b are located in the first image plane of the system composed of the camera objective 12, the composite element 28 and field lens 32, said image plane having been established with the objective 12 set for an object at infinite distance. The deviating wedges provide a discontinuity of light deviation in said image plane along the line of junction of the two wedges. Hence, there is a discontinuity of entrance pupil pertaining to the individual areas covered by each of the wedges. In other words, there is a deviational discontinuity to incident light. If objective 12 is adjusted to focus an object located at a finite distance and if the focus is correct, the image of the object will be formed at said first image plane and the object image portions, because they are focused at said plane, will be deviated in coincidence by the wedges and will provide alignment of split-field areas. If the image of the object is not formed at said first image plane the wedges will deviate the light rays from the object but they will not be in coincidence and the split-field image portions of said object will not be aligned. This occurs because a wedge at an image plane will not shift the apparent position of the image, but a wedge outside the image plane will shift said apparent position of the image. It will be understood that correct alignment of the split-field object image portions implies correct imaging of the object at the focal plane of the camera. When the camera is focused, the film plane, the composite element 28, the field lens 32 and the wedges 34a and 34b are kept in fixed relation to each other to insure operation of the system.

Images of the field of view and of the object formed at the first image plane are twice reflected by prism 36, which may appropriately be a penta prism, and are relayed by relay lens 38 to the second image plane for observation by eyepiece 40. Camera lens 12, field lens 32, relay lens 38 and eyepiece 40 constitute, in effect a terrestrial telescope. The four reflections which

8,003,407

5

occur in elements 28 and 36 are mutually compensating for inversion thus insuring an erect image.

In operating the combined range and view finder of the invention relative to making a photographic exposure, it is assumed that, preliminarily, the camera iris diaphragm at 16 is completely open, the shutter at 16 is open, the light lock 26 is closed and the composite element 28, or other type of auxiliary objective to be described below, is located immediately behind the camera objective. A workable operational sequence for making the photographic exposure would be as follows: The shutter closes; the diaphragm assumes a preset opening value; composite element 28 is removed from the exposure area; the light lock closes; and the shutter opens and closes. A focal plane shutter, not shown, could also be employed and would probably obviate the necessity of providing the light lock.

The combined range and view finder system of FIG. 1 is shown in FIG. 2 incorporated with a camera of a folding type having a bellows 50. The camera objective lens 12 is moved axially by an adjusting knob 52 which, when moved arcuately, actuates mechanism, not shown, providing translational movement of the lens, or one or more elements thereof, along its axis. The composite light-deviating and imaging element 28 is mounted on a pivotal arm 54 which permits the element to be moved to a position out of the area 24 within the angle of view of the objective, as indicated by the broken line. Other optical elements of the finder system are shown mounted in tubular means 56 having a viewing aperture 58.

A modification of the light-deviating element 28 of FIG. 4 is shown in FIG. 5. The semi-transparent mirror 60, formed at the interface of prism elements 62 and 64, terminates short of the extremities of the element. Clear, light-transmitting marginal areas 66 and 68 are thus located adjacent each extremity. A concave reflecting surface 64a, similar to surface 44a of element 28, is provided. In operation, marginal entering light from the camera objective employed for ranging passes through clear areas 66 and 68 of the prism interface and is convergently reflected by surface 64a to surface 60 whence it is reflected upward to field lens 32. Light from the central part of the objective forming other areas of the field of view will necessarily have to pass through the semi-transparent reflecting area 60 before being twice reflected by said surfaces 64a and 60 and a portion of the light will thus be absorbed by said area 60. Accordingly, ranging image areas will appear brighter than other areas of the visible image and the heightened contrast thus provided between the image portions permits greater facility in determining the alignment condition of the split-field images during ranging operation. Other possible modifications of element 28 of FIG. 4 include: forming the concave reflecting mirror on the bottom of the element to utilize light which is deviated downwardly from semi-transparent surface 44 thereto; forming said mirror on the rear surface, as shown, and also on the bottom surface to provide increased light for imaging purposes; mounting negative lens 48 on the front surface of element 28, or on both the front and top surfaces.

FIG. 6 illustrates a range and view finding system which operates substantially similarly to that of FIG. 1 but which employs slightly modified components. A light-deviating and imaging element 70 having portions somewhat modified as to their relative size or arrangement but otherwise similar to those of element 28 of FIG. 1 deviates light from objective 12 obliquely upward toward a modified prism 72. A pair of deviating wedges 34 is positioned between a field lens 32 and a face of prism 72, the wedges preferably being bonded to at least one of the elements 72 and 32. Ranging and view finding considerations, adjustability of components, etc., are similar to those described with respect to FIG. 1.

The system of FIG. 7 employs a pair of positive auxiliary obj

6

prisms or mirrors 80 to form deviating and imaging elements 82. A mirror 84 or a prism having a single reflecting surface is used in place of the twice-reflecting prisms of FIGS. 1 and 6, only one additional reflection being required to provide an erect image in conjunction with the single reflecting surface of element 82. Optical wedges 34, of the type used in the systems above-shown, are located at the second image plane. Other elements of the system are essentially the same as those previously described. In this system the ranging beams are maintained separate until incident upon the second image plane, or approximately at this plane. It is therefore necessary to insure exact alignment of all components between the entrance pupils and the second image plane, or ranging accuracy would be impaired. Decentered lenses may, alternatively, be used in forming the elements 82. The deviating wedges 34 may be located at the first image plane of the system, as shown in FIG. 8, if preferred, or alternatively, they could even be positioned adjacent the auxiliary objectives 78 of elements 82. It will thus be seen that wide latitude is permitted in the placement of wedge components which provides flexibility in the design of the system and in its adaptability to mounting in a camera. A generally similar system to that of FIG. 7 is shown schematically in plan in FIG. 9, mirror surfaces which operate relative to light traveling in a vertical direction being omitted for reasons of clarity.

In FIG. 10 a modified system is illustrated which includes three auxiliary positive objectives, 86, 88 and 90, mounted immediately behind the camera objective 12. A composite prism element 92 having reflecting surfaces 94 and 96, and given reflecting areas of surfaces 98 and 100 which are shown in further detail in FIG. 11, is positioned at the first image plane. Reflecting means of the system which operate relative to light traveling in a vertical direction have been omitted for clarity. Auxiliary objective lenses 86 and 90 could, appropriately, have relatively long focal lengths while auxiliary objective lens 88 could have a relatively short focal length. Higher magnification would thereby be produced in the central ranging area than in the rest of the field. This arrangement provides greater ranging accuracy but leaves a gap in the object field between the area presented by the ranging objectives and the area presented by the central objective. Reflecting surfaces 94 and 96 of composite prism 92 are nonparallel with respect to surfaces 98 and 100, said nonparallelism of surfaces serving to deviate light in a manner similar to that of the optical wedges 34 of FIG. 1. Accordingly, element 92 provides deviation of the ranging light rays so that it may be said to constitute the functional equivalent of the deviating wedges 34a and 34b, above described.

The modification of FIG. 12 illustrates placement of a negative lens 102 in the optical path of light transmitted by the central positive auxiliary objective 88 of FIG. 10. Lens 88, with negative lens 102, constitutes a telephoto lens and, accordingly, the three auxiliary objectives have substantially equal focal lengths. In FIG. 13, an alternate construction is shown for making the focal lengths of all three auxiliary positive objectives, 86, 88 and 90 substantially equal. Glass components 104 and 106 are placed in the optical paths of the outer auxiliary objectives and serve to increase the optical path lengths between said objectives and the first image plane with respect to optical path lengths in air which was shown in FIG. 10. The glass components 104 and 106 are preferably bonded to the auxiliary objectives and to the prism element 92, respectively.

It will be apparent that the systems described herein could be modified in several ways. For example, the deviating wedges could cover the entire field of view; they could be omitted to provide a view finder only; or the area around the deviating wedges could be omitted to deviating

8,003,407

7

wedges, or the mirrors of prism 92, can be located at either the first or second image planes of the system.

Since certain changes may be made in the above product without departing from the scope of the invention herein involved, it is intended that all matter contained in the above description or shown in the accompanying drawings shall be interpreted as illustrative and not in a limiting sense.

What is claimed is:

1. In a photographic camera having an axially adjustable objective lens, a combined finder for viewing and ranging a field of view through said lens, said finder comprising composite light-deviating and imaging means located behind said objective lens, said light-deviating and imaging means being substantially coextensive with a predetermined area which extends transversely of the optical axis of and includes opposite marginal portions of said objective lens, said composite light-deviating and imaging means including a first reflecting means for deviating light from said objective lens to one side of the angular field of said lens along a second axis disposed at a predetermined angle with respect to said optical axis and also including first focusing means which, in combination with said objective lens, effectively constitutes lens means of short focal length for focusing an image of the field of view at a first image plane on said second axis, second focusing means located on said second axis adjacent said first image plane, second reflecting means for deviating light transmitted along said second axis to a third axis substantially parallel with said optical axis, third focusing means positioned on said third axis for relaying said image to a second image plane on said third axis, an eyepiece located on said third axis for viewing said second image plane, second light-deviating means comprising at least two adjacent elements disposed at one of said image planes for so splitting the field of said image into separate and adjacent fields which correspond respectively to light coming from each of said marginal portions of said objective lens that said adjacent fields are continuous when said image is coincident with said one of said image planes and are discontinuous when said image is out of coincidence with said one of said image planes, and means for moving at least said composite light-deviating and imaging means outside of the optical path extending between said objective lens and the focal plane of the camera.

2. A combined range finder and view finder according to claim 1, wherein the composite light-deviating and imaging means comprises a semi-reflecting surface and a concave, spherical reflecting surface for reflecting and focusing light coming from said objective lens and through said semi-reflecting surface back to said semi-reflecting surface.

3. A combined range finder and view finder according to claim 1, wherein the composite light-deviating and imaging means comprises a semi-reflecting surface, a concave, spherical reflecting surface for reflecting and focusing light coming from said objective lens and through said semi-reflecting surface back to said semi-reflecting surface, and a negative lens for correcting aberrations in light reflected from said semi-reflecting surface.

4. A combined range finder and view finder according to claim 1, wherein the composite light-deviating and imaging means comprises a positive lens constituting an auxiliary objective with respect to said camera objective, and means for deviating light transmitted by said auxiliary objective.

5. A combined range finder and view finder according to claim 1, wherein the composite light-deviating and imaging means comprises a plurality of positive lenses constituting a plurality of auxiliary objectives with respect to said camera objective, and means for deviating light transmitted by said auxiliary objectives.

6. A cor-

8

to claim 1, wherein said composite light-deviating and imaging means includes a pair of reflecting surfaces, and wherein said reflecting means for deviating light transmitted along said second axis also includes a pair of reflecting surfaces.

7. A combined range finder and view finder according to claim 1, wherein said second light-deviating means, located at one of said image planes, comprises a pair of optical wedges.

8. A combined range finder and view finder according to claim 1, wherein said second light-deviating means comprises a composite prism element having a plurality of non-parallel surfaces which include given light-reflecting and light-transmitting areas.

9. A combined range finder and view finder according to claim 1, wherein said composite light-deviating and imaging means comprises means for forming an image corrected for spherical aberration.

10. A combined range finder and view finder according to claim 1, wherein said composite light-deviating and imaging means forms two laterally separated image planes at said first image plane, said images being projected for viewing at said second image plane.

11. A combined range finder and view finder according to claim 1, wherein said composite light-deviating and imaging means comprises a semi-reflecting surface, a concave, spherically reflecting surface for reflecting and focusing light coming from said objective lens and through said semi-reflecting surface back to said semi-reflecting surface and a negative lens for correcting aberrations in light reflected from said semi-reflecting surface along said second axis, and wherein said reflecting means for deviating light transmitted along said second axis comprises a penta prism, and wherein the last named light-deviating means comprises a pair of optical wedges.

12. A combined range finder and view finder according to claim 1, wherein said composite light-deviating and imaging means comprises a concave, spherically reflecting surface, a semi-reflecting surface having clear, light-transmitting marginal areas coextensive with said marginal portions of said objective lens, light transmitted through said marginal portions of said objective lens being passed through said light-transmitting marginal areas, being convergently reflected by said concave surface to said semi-reflecting surface to increase thereby the relative brightness of light transmitted by said marginal portions of said objective lens.

13. A combined range finder and view finder according to claim 1, wherein said composite light-deviating and imaging means comprises a positive lens constituting an auxiliary objective with respect to said camera objective and means for deviating light transmitted by said auxiliary objective, and wherein said reflecting means for deviating light along said second axis comprises a plane mirror, and wherein the last named light-deviating means comprises a pair of optical wedges located at said second image plane.

14. A combined range-finder and view-finder according to claim 1, wherein said composite light-deviating and imaging means comprises at least a pair of positive lenses constituting auxiliary objectives with respect to said camera objective, and a composite prism element having a plurality of non-parallel surfaces which include given light-reflecting and light-transmitting areas, said surfaces constituting said second light-deviating means.

15. A combined range-finder and view-finder according to claim 1, wherein said composite light-deviating and imaging means comprises a pair of positive lenses constituting auxiliary objectives with respect to said camera objective, said auxiliary objectives being located to subtend said marginal portions of said objective lens, and a composite prism element located at the image plane of said auxiliary objective, said composite prism element

8,003,407

9

given light-reflecting and light-transmitting areas, said surfaces constituting said second light-deviating means, said combined range-finder and view-finder including optical elements positioned between said auxiliary objectives and said composite prism element for increasing the optical path length between said auxiliary objectives and said first image plane with respect to the optical path length therebetween in air, and a positive lens constituting an auxiliary objective with respect to said camera objective located on the optic axis of said camera objective between the latter and said composite prism element.

5

10

2,341,410
2,352,644
2,364,652
2,887,019

933,132

10

References Cited in the file of this patent

UNITED STATES PATENTS

Mihalyi ----- Feb. 8, 1944
Linderman et al. ----- July 4, 1944
Pollock ----- Dec. 12, 1944
Dodin ----- May 19, 1959

FOREIGN PATENTS

Germany ----- Sept. 15, 1955

May 6, 1969

A. B. PAGEL

3,442,193

AUTOMATIC FOCUSING SYSTEM

Filed May 31, 1966

Sheet 1 of 2

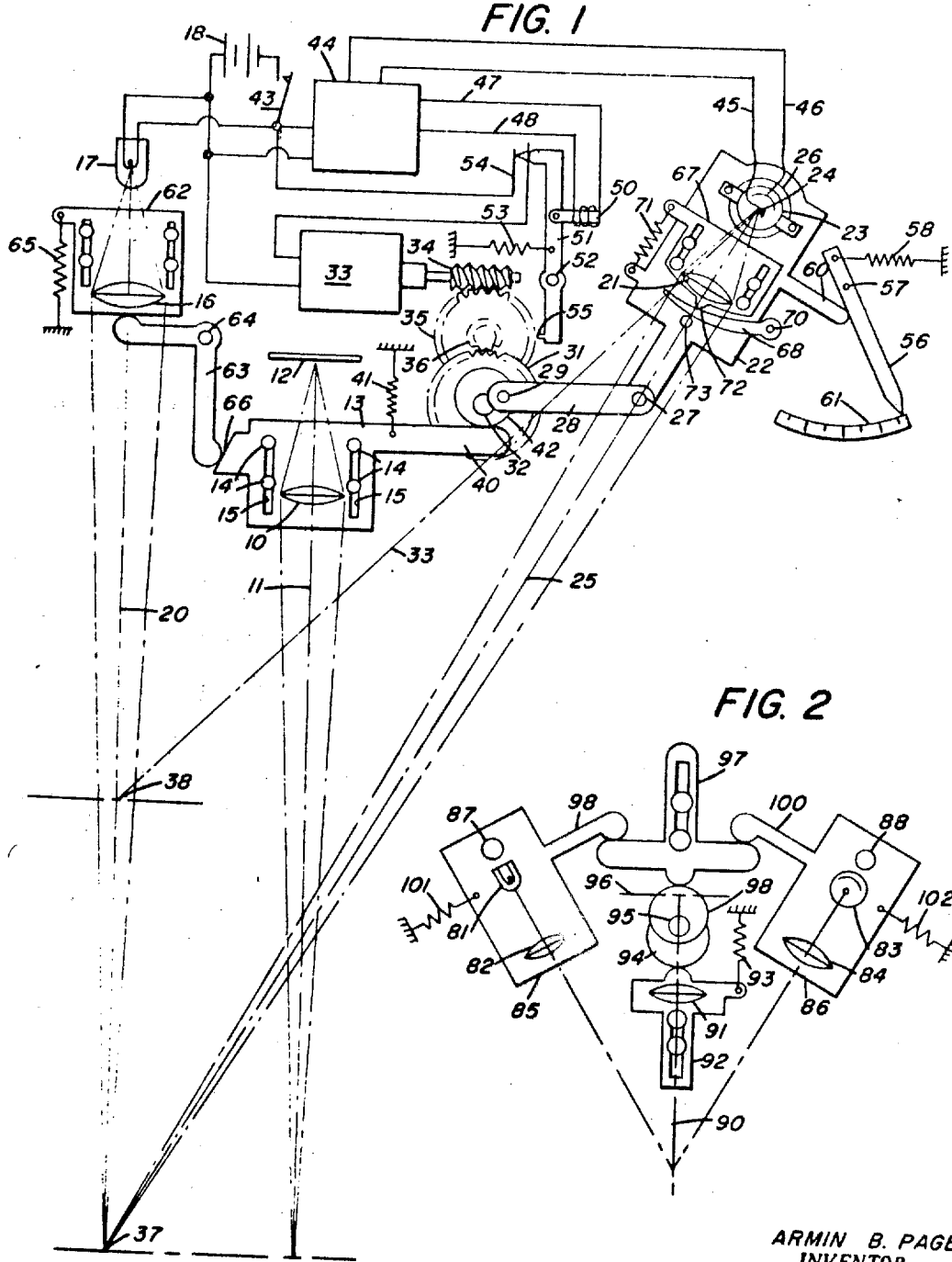

ARMIN B. PAGEL
INVENTOR.

BY *Morton A. Solter*
Robert W. Hampton
ATTORNEYS

May 6, 1969

A. B. PAGEL

3,442,193

AUTOMATIC FOCUSING SYSTEM

Filed May 31, 1966

Sheet 2 of 2

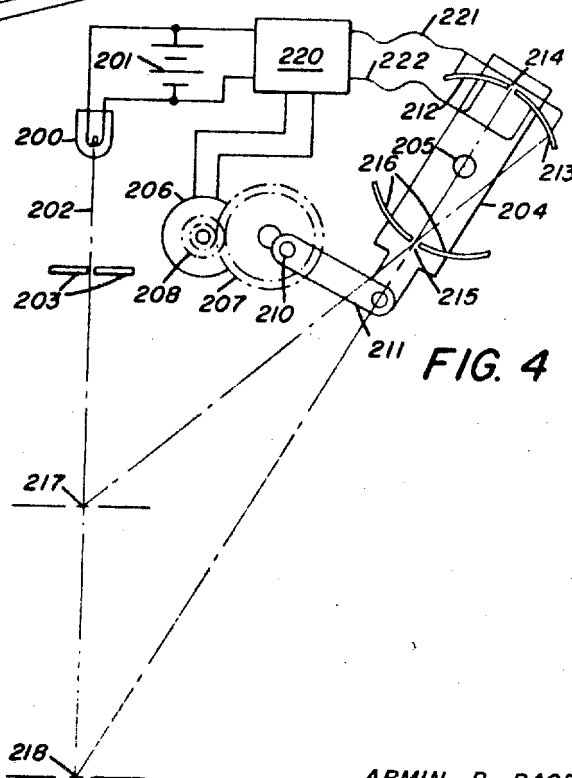
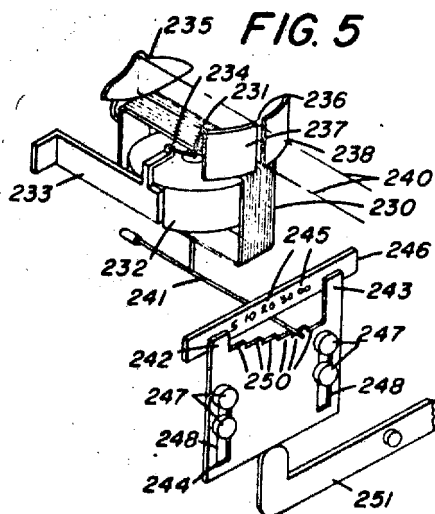
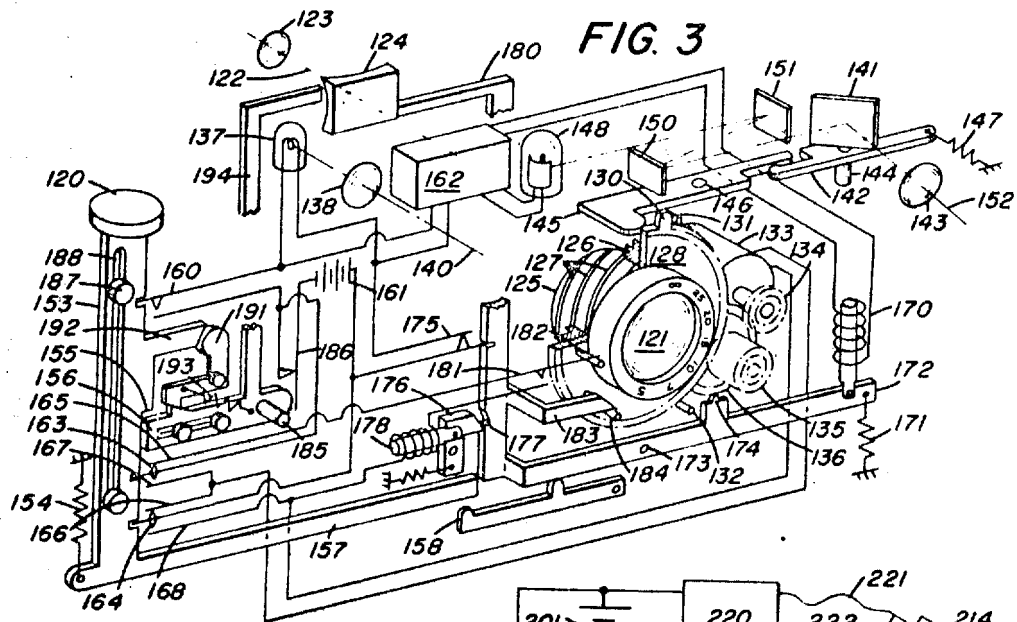

ARMIN B. PAGEL
INVENTOR.

BY *Morton W. Olster*
Robert W. Naughton
ATTORNEYS

1

3,442,193

AUTOMATIC FOCUSING SYSTEM

Armin B. Pagel, Janesville, Wis., assignor to Eastman Kodak Company, Rochester, N.Y., a corporation of New Jersey

Filed May 31, 1966, Ser. No. 559,633

Int. Cl. G03b 3/10

U.S. Cl. 95-44

15 Claims

ABSTRACT OF THE DISCLOSURE

An automatic focusing system for a camera in which a beam of light is directed toward a subject from a light source within the camera and a portion of the light beam reflected from the subject back to the camera is sensed by photoelectric means. The angle between the emitted and reflected beams is translated into a mechanical movement which is a function of the distance from the camera to the subject. The projected and reflected beams are focused in accordance with the distance to the point of reflection and there is a mechanism providing for sequential operations which insures completion of various adjustments prior to exposure.

This invention relates to automatic focusing apparatus of the type described in the copending application for Automatic Focusing System, Ser. No. 554,072, filed on May 31, 1966, in the name of Allen G. Stimson.

The present invention relates to photographic cameras or related optical instruments and, more particularly, to such instruments embodying fully automatic means for determining the distance from the instrument to the object to be brought into focus.

Further, the present invention is an improvement relating to the automatic focus apparatus disclosed in copending U.S. application Ser. No. 554,072 filed in the name of A. G. Stimson on May 31, 1966.

During the evolution of the modern photographic camera, continuing attempts have been made to minimize the numerous visual observations, subjective determinations and manual operations usually involved in adjusting shutter speed, lens aperture and focus of the lens to achieve a photograph of optimum quality. Many cameras now on the market incorporate light meter means which automatically adjust the shutter and/or lens opening in response to the illumination of the scene to be photographed. However, although many present-day cameras incorporate devices which enable the operator to focus the lens properly by visually observing the quality or composition of one or more images of the subject to be photographed, no commercially successful device has thus far been developed to adjust the focus of the lens automatically without necessitating any such visual observations. Accordingly, many cameras, including some of relatively high price, are now provided with so-called universal focus lenses, which do not require focusing adjustment within the distance range usually encountered by the amateur photographer. Such lenses, however, are a compromise between eliminating focusing problems and providing an image of optimum quality, and, therefore, are not satisfactory under all conditions.

The basic principle employed in the invention disclosed in the Stimson application referred to above involves directing onto the subject a beam of light emitted from a light source positioned in predetermined relation to the camera; receiving, at a location spaced laterally from the emitted beam, a portion of the beam reflected back to the camera from the subject; sensing the angle between the emitted and the reflected beams by bringing the reflected portion of the beam into alignment with

2

photoresponsive sensing means; and translating the angle so sensed into a corresponding mechanical movement.

The subject invention improves the basic Stimson range-finding system by automatically focusing the projected and reflected beams in accordance with the distance to the point of reflection, thereby increasing the efficiency of the range-finding portion of the apparatus, and by providing for completion of camera lens focus adjustment prior to camera shutter actuation, the latter sequential operations assuring that the light beam used for range-finding purposes will be extinguished prior to actual picture-taking.

It is therefore an object of the present invention to increase the efficiency of automatic range-finding apparatus which uses a projected light beam.

It is a further object to focus both the projected light beam and its reflection, and to adjust such focus automatically in accordance with the distance to the point of reflection.

Another object is to increase the efficiency of automatic range-finding apparatus for cameras by assuring that the camera lens is focused and its projected light beam extinguished prior to operation of the camera's picture-taking shutter mechanism.

The novel features considered characteristic of the invention herein are set forth with particularity in the appended claims. The invention itself, however, both as to its organization and method of operation, together with additional objects and advantages thereof, will best be understood from the following description of illustrative embodiments and from the accompanying drawings in which:

FIG. 1 is a schematic diagram of one embodiment of a range-finder device according to the present invention, including means for focusing the objective lens of an optical instrument in response to the distance between the instrument and the subject;

FIG. 2 is a schematic diagram of another embodiment of a range-finding device according to the present invention, in which the light beam projecting unit and the reflected beam detecting unit are symmetrically disposed on opposite sides of the axis of an axially adjustable lens and are coupled for symmetrical movement, whereby the detected point of impingement of the light beam on the subject is located along such axis at all positions of the range finder mechanism;

FIG. 3 is a schematic perspective illustration of a preferred embodiment of the present invention, incorporated in a photographic camera to determine automatically the distance between the camera and the subject and to effect a corresponding setting of the camera lens;

FIG. 4 is a schematic diagram of still another embodiment of a range-finder device showing an alternate means for detecting the alignment of the reflected beam with the light sensing element thereof; and

FIG. 5 is an isometric view of yet another embodiment of a light-sensing means, comprising a galvanometer-type electrical measuring instrument adapted to align itself with a light beam, and including means for translating mechanically the aligned position of the movable portion of the instrument to establish the corresponding position of a movable mechanical element.

Referring now to FIG. 1 of the drawing, element 10 represents generally the lens system of a photographic camera or other optical instrument in which a lens system is movable along its axis to focus, at an image-receiving surface illustrated at 12, an image of a subject located along the lens axis. The lens system is moved as a function of the distance between the subject and the lens system. For purposes of illustration, lens system 10 is shown mounted on plate 13 which in turn, is movably

3

attached to a supporting surface, not shown, by pins 14, which extend through parallel slots 15 to allow sliding movement of the plate along the axis 11, of lens 10.

A second lens system, represented generally at 16, is located in alignment with a light source 17 energized by a battery or other source of electric energy 18, and is adapted to project a beam of light along the lens axis 20 which, in the illustrated embodiment, is located in fixed parallel relation to lens axis 11. Thus, the beam of light will impinge upon a subject located along axis 20, which subject would presumably present a frontal surface generally transverse to the light beam and of sufficient width to also be in alignment with lens system 10, thereby constituting the object intended to be brought into sharp focus by lens 10. Although not shown in the illustration, it is obvious that a conventional viewfinder device could be employed to establish the alignment of lens system 10 with the subject.

The light sensing system employed to detect the spot of light impinged upon the subject and at least partially reflected therefrom, comprises a third lens system, depicted generally at 21, which is mounted on a support member 22 in alignment with a photoelectric device 23, the light responsive portion 24 of which is disposed in alignment with the axis 25 of the third lens system. (While the photoelectric device is represented in the drawing as a photoelectric vacuum tube, other types of similar devices, including photoresistive or photovoltaic solid state devices, can also be employed. Hence, the term photocell, as used herein, is intended to refer to any such device which may be employed in connection with appropriate circuitry to generate or control an electric signal as a function of the illumination impinging on the device.) Support member 22 is pivoted for arcuate planar movement on a fixed shaft 26 which, in the illustrated embodiment, is axially aligned with the light responsive portion of photocell 23. The opposite end of the support member is provided with a pin 27 and is thereby joined, through connecting rod 28, to crank pin 29 which is eccentrically mounted on gear member 31 to move orbitally about the axis of gear shaft 32 as gear 31 is rotated by motor 33 through speed reduction gears 34, 35, and 36.

When a subject is located along axis 20 in the path of the beam of light emitted by light source 17, the beam will impinge upon the frontal surface of the subject and will be at least partially reflected. However, before a portion of the reflected beam can be detected by the light sensing system and generate a corresponding electric signal, the axis 25 of the light sensing system must be positioned to coincide with the frontal reflective surface of the subject along axis 20 to cause the illuminated area on the subject to be focused at the light sensitive portion of the photocell. For example, with the light sensing system positioned as indicated in FIG. 1, its electric signal will be produced only when the frontal reflective surface of the subject is substantially at point 37.

Thus, as the light sensing system is reciprocated arcuately, it scans the portion of axis 20 between point 37 and point 38 and produces an electric signal responsive to the focusing of reflected light onto the sensitive portion of the cell whenever axis 25 traverses a reflective frontal surface along axis 20 between these two points. The distance from the instrument of points 37 and 38 depends, of course, on the particular design of the device. In the case of a camera, points 37 and 38 might correspond, respectively, to the so-called hyperfocal distance (beyond which further focusing adjustment is not normally required) and to the nearest distance at which the camera is intended to photograph a subject.

To effect the automatic focusing of lens 10 according to the distance from the subject to the camera, support member 13 is provided with a cam follower arm 40 which is resiliently biased by a spring 41 into engagement with a cam 42 (secured to gear 31) so that the rotative posi-

4

tion of gear 31, and hence the angular position of the light sensing system, correspondingly determines the position of lens 10 relative to image receiving surface 12. While the drawing shows simply a circular cam 42 adapted to increase the distance between lens 10 and surface 12 as the point of coincidence between axes 20 and 25 move away from the instrument, or vice versa, in actual practice the cam could have a non-circular profile determined by the relative positions of the various elements involved and their particular optical characteristics.

The operation of the illustrated device is initiated by closing switch 43, thereby electrically energizing light source 17, motor 33 and an electric transducer device 44 connected to photocell 23 by leads 45 and 46. Transducer 44 is adapted to supply current to energize solenoid 50, through output at leads 47 and 48, whenever photocell 23 responds to the presence of a predetermined increase in light intensity.

As soon as the motor is energized, the light sensing system begins to scan axis 20 between points 37 and 38 and continues to do so until the intersection of axes 20 and 25 coincides with a reflective surface, at which position a portion of the reflected light is focused on the photocell, in response to which solenoid 50 rotates latch arm 51 about pivot 52 against the influence of spring 53 to open switch 54, thereby deenergizing motor 33. To insure instant response of the system independent of the inertia of the motor and other moving parts, the latch arm may also be provided with a tooth 55 which, upon actuation of the solenoid, is interposed between two adjacent teeth of gear 35 to effect an immediate and positive braking action, thus stopping the motion of all the movable elements of the device in appropriate positions as a function of the distance of the subject from the instrument. This distance may also be related as a numeric value by a pointer member, as shown at 56, which is pivotally mounted at pivot 57 and movable against spring 58 by an arm 60 connected to support plate 22, such that the angular position of the support plate may be translated into a direct distance reading by an appropriately numbered scale 61 in alignment with the pointer.

Although the foregoing description has used the term "light" in a general sense in referring to the emitted light beam and the light sensing means, it should be noted that to minimize the possibility of ambient light impinging on the photocell and causing a spurious motion stopping signal, the associated electric transducer device should be so designed as to be responsive only to illumination by a range finder light source of greater intensity than the normally encountered illumination of the subject by other sources. Rather than simply providing an extremely intense source of visible light, however, it is preferable to utilize a photocell which is responsive primarily only to light within a particular spectral frequency range which is not preponderant in normal ambient light, and to provide a light source which emits primarily light within that frequency range. For example, a preferred embodiment of the range-finding device might employ light outside of the ordinary visible spectrum (e.g., infrared or ultraviolet) with other frequency components being minimized both in the emitted beam and in the light received at the photocell by appropriate optical filters. Alternatively, a beam of relatively intense monochromatic light might be employed, for example, by use of an optical laser as the light source, with a corresponding narrow band filter being used in conjunction with the photocell.

While the foregoing explanation describes the essential elements and mode of operation of the device, it may for some purposes also be desirable to further increase the accuracy of the device by insuring not only that the subject is in sharp focus at surface 12 at all times, but also that the lens system 16 and 21 are continuously adjusted so that the point of intersection between axes 20 and 25 is continuously maintained in alignment with the point of

5

and the photocell. To obtain this objective, the light beam projecting lens 16 is mounted on a plate 62 which corresponds in structure to support member 13 of lens 10, whereby lens 16 may be moved along its axis 20 to vary its position relative to light source 17. This adjustment of lens 16 is effected by a bell crank 63 pivoted at 64, which moves plate 62 against the influence of spring 65 in appropriate relation to the movement of support plate 13 as a function of the profile of cam surface 66 thereon. Likewise, lens 21 is also supported on support member 22 by a similar plate member 67 for movement along axis 25, with the distance between the lens and the photocell being adjusted as a function of the angular position of member 22 by a curved tapered cam arm 68 fixed to a stationary portion of the instrument at 70 and held in by a spring 71 in contacted engagement between lobe 72 at the forward end of plate member 67 and a pin 73 fixed to support member 22.

Referring now to the embodiment of the invention shown in FIG. 2, the light beam projecting device, comprising light source 81 and lens 82 and the light sensing system, comprising photocell 83 and lens 84, are mounted respectively on support plates 85 and 86 symmetrically located at pivot points 87 and 88 on opposite sides of the axis 90 of a lens system 91 of a camera or other optical instrument. Lens system 91, in turn, is supported by a mounting plate 92 movable along axis 90 against the influence of spring 93 by a cam 94 attached to a rotatable shaft 95, to vary the distance between the lens and the image receiving surface depicted at 96. A symmetrical cam follower member 97, positioned in contact with a second cam 98 attached to shaft 95 is also movable along axis 90 in response to the rotation of shaft 95 and is resiliently engaged by the respective arms 98 and 100 of plates 85 and 86 under the influence of springs 101 and 102. In this construction, therefore, the axes of the light beam projecting device and the light sensing system at all times converge at axis 90, such convergence point being kept in focus at surface 96 by lens 91. Such a system, in association with a drive mechanism and associated circuitry as shown in FIG. 1 would, therefore, eliminate entirely the lateral discrepancy between the sensed position of the subject and the axis of the instrument, which might constitute an unacceptable degree of parallax if, for example, the device were to be used for accurate long range measurements in connection with surveying, weapon aiming, or the like.

FIG. 3 illustrates a camera having a fully automatic system responsive to depression of the shutter actuating button 120, to first automatically focus the objective lens 121 according to the distance between the camera and a subject located along the axis 122 of the viewfinder comprising lenses 123 and 124, and, thereafter, to actuate the shutter mechanism to effect an exposure.

The embodiment illustrated in FIG. 3, utilizes a range-finding system which utilizes the same general principle of operation as that previously described in relation to the structure shown in FIG. 1. Objective lens 121 is mounted in a cylindrical housing 125, and is supported in the camera housing, not shown, by a stationary ring 126. The rearward portion of lens housing 125 and the internal surface of ring 126 are provided with mating threads, as shown at 127, whereby the rotation of housing 125 in a counterclockwise direction, as viewed from the front of the camera, moves the lens forwardly away from the film, not shown, and vice versa. Attached to lens housing 125 is a gear member 128 which is rotatable, through somewhat more than a half revolution, between the illustrated position in which lug 130 at the periphery thereof is in contact with a stationary stop pin 131 and a second position in which lug 130 contacts stationary stop pin 132. This rotation of housing 125 is sufficient to move lens 121 axially through its entire range of focal adjustment as indicated by indicia shown on the front surface of the housing adjacent the lens. As hereinafter described, gear

6

128 may be rotated in the manner just described, either by (1) a reversible electric motor 133 connected thereto through a speed reducing gear train 134, 135 and 136, or (2) by simply rotating the accessible forward portion of housing 125 manually, thereby rotating the motor through the gear train.

The light beam emitting device built into the camera comprises an electrically energized light source 137 mounted at the focal point of a lens 138, the axis 140 of which is parallel to the axis of the objective lens 121. The light sensing device includes a mirror 141, angularly located on support arm 142 behind a third lens 143 and movable about a vertical axis defined by pin 144 pivotally supporting arm 142 on the camera housing. The angular position of mirror 141 is determined by the axial position of the objective lens by means of a follower arm 145 which is pivoted to the housing at 146. One end of the follower arm 145 is held in resilient contact with the back surface of gear member 128 by the contacting engagement of the other end thereof with support arm 142 under the influence of spring 147, whereby a forward movement of the objective lens moves mirror 141 in a clockwise direction, as viewed from the top, and vice versa. Photocell 148 is optically aligned with mirror 141 by means of fixed intermediate mirrors 150 and 151, which serve to increase the focal distance between the lens 143 and photocell 148 and also to increase the optical distance between mirror 141 and the photocell, thereby increasing the movement of a focused spot of light at the photocell in response to a given angular movement of the mirror.

Although each of the light sensing systems previously described in relation to the embodiments illustrated in FIGS. 1 and 2 involves moving a lens relative to a photocell to effect a scanning function, the same result is achieved in this embodiment by moving the mirror behind the stationary lens 143 while simultaneously carrying out a corresponding movement of the objective lens. For example, in the position shown in FIG. 3, the objective lens 121 is in its rearwardmost (hyperfocal) position, and, at the same time, mirror 141 is positioned to focus at the photocell only such light beams as are reflected from a subject located beyond the hyperfocal range of lens 121.

To take a picture with the camera shown in FIG. 3, the operator first brings the photographic subject into the field of the viewfinder. Next, he depresses the shutter actuating button 120 to initiate the operation of the camera by moving slidable member 153 downwardly, against the influence of spring 154. When the camera is set for fully automatic operation, the downward motion of member 153 is limited by engagement of its shoulder 155 with stop member 156. In this position, the shutter release arm 157 of member 153 has not operatively engaged shutter-actuating trigger 158. However, such downward movement of member 153 closes normally open switch 160 in series with a battery 161 to energize light source 137 and an electric transducer device 162 similar to the one described in reference to FIG. 1. Further, such movement of member 153 simultaneously actuates a double-pole double-throw switch comprising movable contact blades 163 and 164, moving such blades out of contact with conductors 165 and 166, respectively, and into contact with conductors 167 and 168. This causes motor 133 to be energized by battery 161 with the proper polarity to drive gear member 128 in a counterclockwise direction, thereby axially moving lens 121 and causing the range-finding system to function as previously described.

When the scanning movement of mirror 141 causes the reflected beam of light to impinge on the photocell 148, transducer 162 energizes a solenoid 170 which, acting against the bias of spring 171, moves actuating arm 172 in a counterclockwise direction about its pivot 173, forcing its tooth 174 between adjacent teeth of gear 136 to cause an immediate and positive stoppage of the drive system. In this embodiment, however, the motor remains energized and is simply stalled by the blocking of gear

able member by means, not shown, corresponding to those previously illustrated and described.

While photocell elements 212 and 213 were previously described as being rectangular, it may be preferable to utilize such elements having frontal profiles which decrease in vertical dimension toward each other, whereby the area upon which the vertical light beam impinges is reduced as the system approaches alignment with the illuminated area of the subject. By utilizing such an arrangement, the motor energizing voltage can be reduced gradually toward an apex (in this case "zero") output as a function of the size of the illuminated area of the photocell, thereby slowing the speed of the motor as the system moves into alignment and reducing the inertia of the drive mechanism which tends to carry plate 204 past the aligned position in which the drive motor is de-energized.

FIG. 5 illustrates still another embodiment of a light sensing system which may be incorporated in an automatic range finder as previously described. In this embodiment, the light sensing system utilizes a galvanometer-type electrical measuring instrument comprising a movable coil 230 pivotally supported by two jeweled bearings, one of which is shown at 231, at opposite sides of a permanent magnet 232, supported by a stationary support arm 233. In such an instrument, the angular deflection of the coil against the slight resistance of a hair-spring 234 is a function of the amount of current flowing through the coil. In this embodiment, such current is produced by a photovoltaic-type cell 235 mounted on coil 230 in alignment with a vertical slit 236 between aperture plates 237 and 238, which are also supported on the coil and which define a narrow vertical scanning path illustrated by broken lines 240.

The light measuring system shown in FIG. 5 may be mounted on a camera or other instrument in the same manner as described in reference to the system illustrated in FIG. 4. The scanning range of the system, is defined by the limits of motion of needle 241, which is attached to the coil for arcuate movement between legs 242 and 243 of step member 244, and so long as the subject is located along the axis of the light source and within the scanning range of the system, light reflected from a subject will always impinge on some portion of the photocell. By profiling photocell 235 so that a maximum area thereof is illuminated when path 240 is aligned with the reflected spot of light at the subject, an apex (maximum) current output is produced at the point of proper alignment, and the system can be made to align itself automatically. With the illuminated spot reflected from the subject being aligned with the maximum cell area, the position of needle 241 is therefore determined by the distance of the subject from the camera as may be indicated by appropriate indicia 245 on stationary anvil member 246.

Alternatively, other means might be employed modifying the embodiment shown in FIG. 5 to cause the electric signal of the photocell to change in a similar manner as illuminated area moves either way from the aligned central position. For example, instead of/or in addition to varying the area of the photocell, a transparent filter member varying in density toward each end might be moved across the light path by the coil to vary the intensity of the illumination of the photocell as a function of the position of the object. To stabilize such a self-aligning galvanometer system and prevent undue oscillation thereof, it is necessary to determine carefully the desired profile of the photocell, the characteristics of the hairspring, and other operative elements associated with the instrument, as well as to provide appropriate damping means, but such considerations are within the province of persons skilled in the electric meter art.

To translate the position of the needle into a corresponding adjustment of the camera lens or some other element, step plate 244 is slidably supported by stationary pins 247 extending through parallel slots 248 and is provided with a series of steplike surfaces 250, whereby

needle 241 is trapped between one of such surfaces and the lower surface of anvil member 246 to block further movement of plate 244 as the plate is moved upwardly by operating lever 251. Accordingly, the blocked position of the plate, and/or the corresponding position of operating lever 251, reflect the angular orientation of the light sensing system and can readily be translated into the desired corresponding mechanical movement needed to focus the optical system.

FIG. 5 represents both the photocell and the associated scanning path defining means as being movable with the coil. However, it should be apparent that the coil might carry only a mirror or some other single movable element of the light sensing system as has been illustrated by the various embodiments previously described. Although the latter varieties necessitate flexible electrical connections to the coil, they might nevertheless be preferable to reduce the mass of the movable coil structure.

While the various embodiments of the invention herein have been described with reference to instruments having a movable lens or other element separate from the elements of the range-finder device itself, it would also be possible to utilize the instrument lens for purposes of focusing the light beam onto the subject or focusing the reflected beam onto the photocell. For example, to adjust the projection lens of a projector as a function of the distance to the screen, an aperture plate could temporarily be introduced to restrict the projection beam to illuminate only a small spot on the screen for detection by the photocell, and, after the lens was adjusted, the plate could be removed to allow the projector to function in its normal manner. Likewise, in a camera, a mirror could be interposed temporarily behind the camera lens to focus the reflected beam onto the photocell, and then removed after the distance setting had been accomplished, in a manner similar to that employed in the viewfinder device of a single lens reflex camera.

The invention has been described in detail with particular reference to preferred embodiments thereof, but it will be understood that variations and modifications can be effected within the spirit and scope of the invention. Accordingly, the invention is not to be limited to the specific details shown and described, but is of a scope as defined by the appended claims.

I claim:

1. In a photographic camera having:

- (a) exposure means for exposing an image receiving surface within said camera to illumination from a scene to be photographed in response to actuation of said exposure means; and
- (b) trigger means for actuating said exposure means, the improvement comprising:
 - (c) rangefinder means including means
 - (1) for projecting a light beam toward a subject to be photographed to impinge on the surface thereof and
 - (2) for receiving a portion of said beam reflected from said surface;
 - (d) beam disabling means for terminating the impingement of light on the surface of said subject; and
 - (e) coordinating means operatively connecting said beam disabling means and said trigger means for terminating said impingement prior to the actuation of said exposure means.

2. A photographic camera according to claim 1 wherein said beam disabling means includes light beam extinguishing means for terminating the projection of said light beam.

3. In a camera having:

- (a) a film plane,
- (b) actuatable shutter means for controlling the transmission of light to said film plane, and
- (c) actuatable rangefinding means including a member positionable automatically as a function of the

11

distance from said camera to a subject to be photographed;

the improvement comprising:

(d) trigger means for sequentially actuating said rangefinding means and said shutter means, whereby said shutter means is actuated only after said member has been positioned by said rangefinding means.

4. The camera structure according to claim 3 further including: an objective lens, focusing means for varying the distance between said lens and film plane, and means operatively connecting said positionable member and said focusing means for automatically adjusting said focusing means to vary the distance between the lens and film plane in accordance with the position of said member.

5. The camera structure according to claim 3 further including indicator means responsive to said positionable member for indicating the distance from the camera to said subject.

6. The camera structure according to claim 5 further including a viewfinder, said indicator means being visible in said viewfinder.

7. In a photographic camera having:

(a) an image receiving surface;

(b) an objective lens;

(c) shutter means for exposing said image receiving surface to an image formed by said objective lens;

(d) focusing means for adjusting said objective lens to different focal positions varying the distance between said lens and said surface;

(e) a rangefinder system comprising:

(1) a light source unit including means for projecting a light beam to produce an area of illumination on an object to be photographed when said beam impinges thereon;

(2) a directional light sensing unit spaced from said light source unit and including light responsive means for producing a predetermined electric signal when said light responsive means and said area are in alignment;

(3) drive means for moving at least one of said units to bring said light responsive means and said area into alignment by altering the angular relation between said units;

(4) braking means responsive to said signal for arresting said drive means when said light responsive means and said area are in alignment;

(f) adjustment means operatively connected to at least one of said units and to said focusing means to position said lens at a focal position corresponding to the distance from the camera to said object as a function of the spatial and angular relation of said units when said drive means is arrested;

the improvement comprising:

(g) light control means for terminating the impingement of said light beam on said object;

(h) a trigger member; and

(i) actuating means responsive to movement of said trigger member for sequentially actuating:

(1) first, said rangefinder system and said adjustment means to adjust said lens according to the distance from the camera to the subject,

(2) second, said light control means to terminate the impingement of said light beam on said object, and

(3) finally, said shutter means to expose said image receiving surface.

8. A camera according to claim 7 further comprising:

(a) latching means operable to

(1) a first condition to retain said lens in its adjusted focal position when said braking means arrests said drive means in response to said predetermined signal, regardless of subsequent alteration of said signal; and

(2) a released condition to permit adjustment of the focal position of said lens; and

12

(b) means responsive to said shutter means for operating said latch means to its released condition upon completion of the exposure of said image receiving surface by said shutter means.

9. A photographic camera according to claim 7 further comprising:

(a) a viewfinder; and

(b) indicator means visible in said viewfinder for indicating the actuation of said shutter means.

10. A photographic camera according to claim 7 further comprising: override means including a manually operable override element movable from a first position to a second position for disabling said actuating means to allow said shutter means to be operated independently of said actuating means.

11. A photographic camera according to claim 10 further comprising:

(a) means for releasably retaining said override element in said second position upon movement of said element to said second position; and

(b) means for returning said element to said first position in response to movement of said trigger means, whereby said element must be moved manually to said second position prior to each exposure to be made independently of said actuating means.

12. A photographic camera according to claim 10 further comprising:

(a) a viewfinder; and

(b) override indicator means visible in said viewfinder for indicating the position of said movable element.

13. In the combination of a photographic camera having an objective lens adjustable to different focal positions and a rangefinding device having distance triangulating means including:

(a) a light source unit adapted to project a beam of light toward an object to be photographed to produce an illuminated area on said object when said beam impinges thereon; and

(b) a directional light sensing unit spaced from said light source means for producing a predetermined electric signal when said light sensing means and said area are in alignment;

the improvement comprising:

(c) adjustable lens means associated with at least one of said units, said lens means being adjustable to vary the position of a focal point thereof;

(d) drive means for moving at least one of said units through a plurality of positions to bring said light sensing means and said area into alignment;

(e) focusing means responsive to the position of at least one of said units for adjusting said focal position of the lens means during such movement as a function of the angular and spatial relation of said units;

(f) braking means responsive to said signal for arresting said drive means when said light sensing means and said area are in alignment; and

(g) indicator means operatively connected to at least one of said units to indicate the distance from the camera to said object as a function of the spatial and angular relation of the units when said drive means is arrested.

14. The combination according to claim 13 further comprising: adjustment means responsive to said indicator means for adjusting the focal position of said objective lens as a function of the spatial and angular relation of said units when said drive means is arrested.

15. A photographic camera comprising:

(a) an objective lens;

(b) means defining a surface upon which an image formed by said lens will be in focus when said lens and said surface are spaced by a first distance functionally related to a second distance between said lens and the object defining said image;

(c) movable means for adjusting said first distance between said lens and said surface;

3,442,193

13

- (d) a light lens means having an adjustable focal point for projecting a beam of light from said unit along a narrow first path to produce a localized illuminated area on said subject when said first path is aligned therewith;
- (e) a light sensing unit including:
 - (1) photoresponsive means adapted to produce a predetermined electric signal when in optical alignment with an illuminated area; and
 - (2) a second lens means having an adjustable focal point for defining a narrow second path within which an illuminated area is in such signal-producing alignment with said photocell unit, said second path being angularly disposed with respect to said first path and in intersecting relation therewith;
- (f) drive means for moving at least one of said units to alter the angular relation of said paths and the point of intersection thereof;
- (g) rangefinder focusing means responsive to said drive means for adjusting the focal point of at least one of said first and second lens means as a function of the position of said drive means;
- (h) disabling means for arresting said drive means in

5

10

15

20

14

- response to said signal when said point of intersection and said illuminated area on said object are in coincidence; and
- (i) image focusing means operatively connecting said drive means and said movable means for varying said first distance as a function of the position of said drive means.

References Cited

UNITED STATES PATENTS

| | | | | |
|-----------|---------|-----------------|-------|---------|
| 1,866,581 | 7/1932 | Simjian | ----- | 352-140 |
| 2,701,500 | 2/1955 | Schwartz et al. | | |
| 2,811,908 | 11/1957 | Nerwin. | | |
| 3,249,006 | 5/1966 | Stauffer | ----- | 352-140 |
| 3,264,935 | 8/1966 | Vose | ----- | 352-140 |
| 3,342,102 | 9/1967 | Maxon | ----- | 352-140 |
| 3,367,254 | 2/1968 | Townsley | ----- | 95-44 |

NORTON ANSHER, *Primary Examiner.*

C. B. FUNK, *Assistant Examiner.*

U.S. Cl. X.R.

88-2.4

Oct. 7, 1969

R. H. STUDEBAKER

3,471,234

LASER BEAM PROJECTOR FOR SURVEYING OPERATIONS

Filed June 8, 1966

4 Sheets-Sheet 1

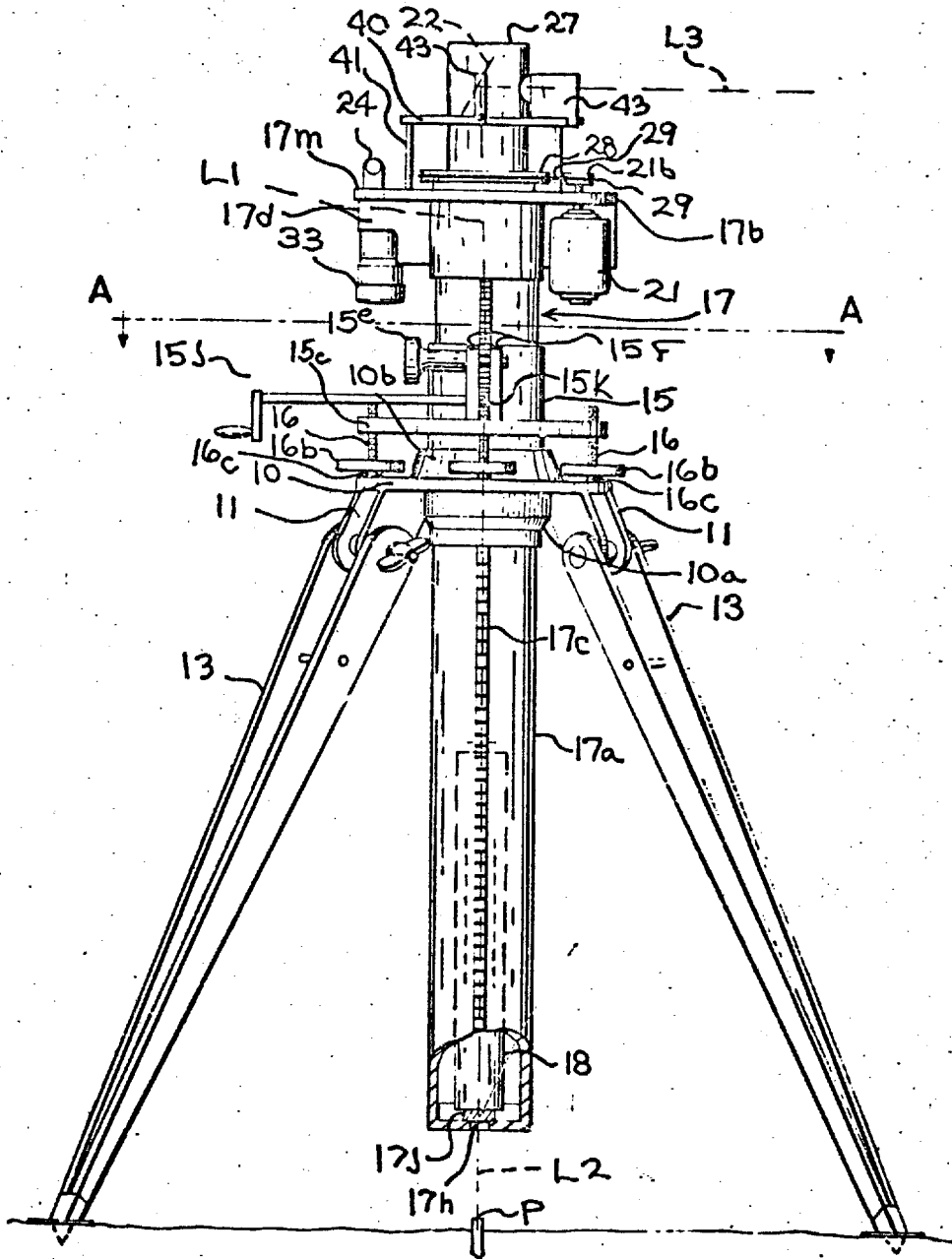

FIG. 1

INVENTOR
ROBERT H. STUDEBAKER
BY W. A. Schleich &
Thomas A. Neelhan
ATTORNEYS

Oct. 7, 1969

R. H. STUDEBAKER

3,471,234

LASER BEAM PROJECTOR FOR SURVEYING OPERATIONS

Filed June 8, 1966

4 Sheets-Sheet 2

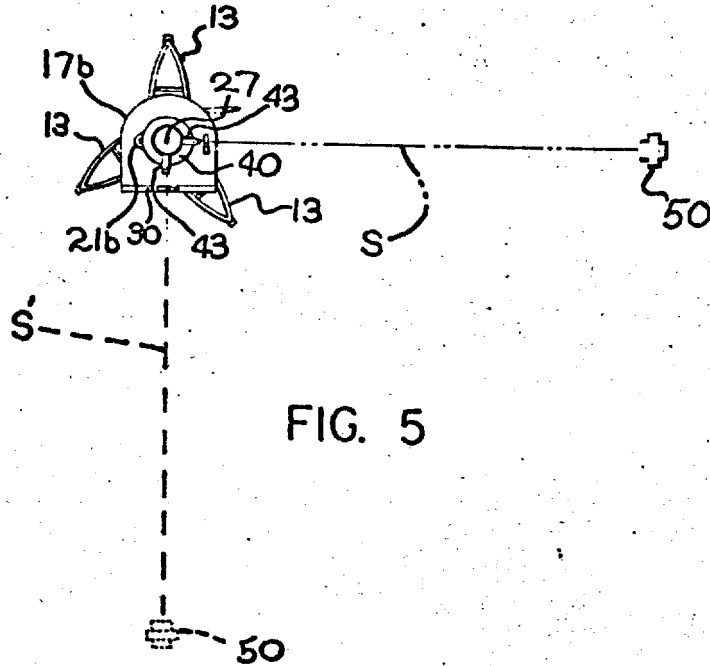

FIG. 5

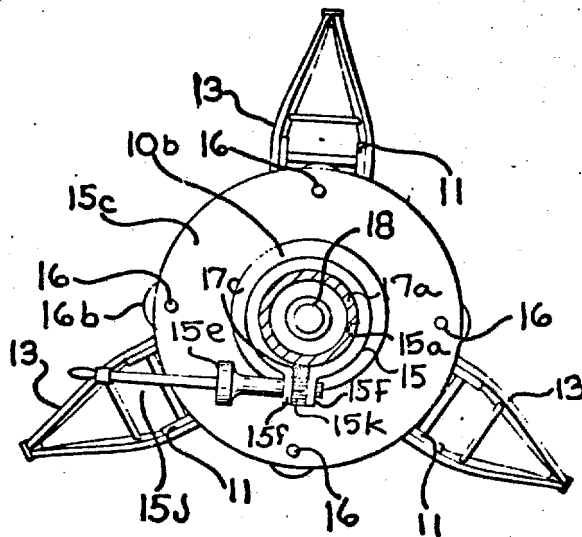

FIG. 2

INVENTOR
ROBERT H. STUDEBAKER
BY W.A. Schaich &
Thomas A. Meehan
ATTORNEYS

Oct. 7, 1969

R. H. STUDEBAKER

3,471,234

LASER BEAM PROJECTOR FOR SURVEYING OPERATIONS

Filed June 8, 1966

4 Sheets-Sheet 3

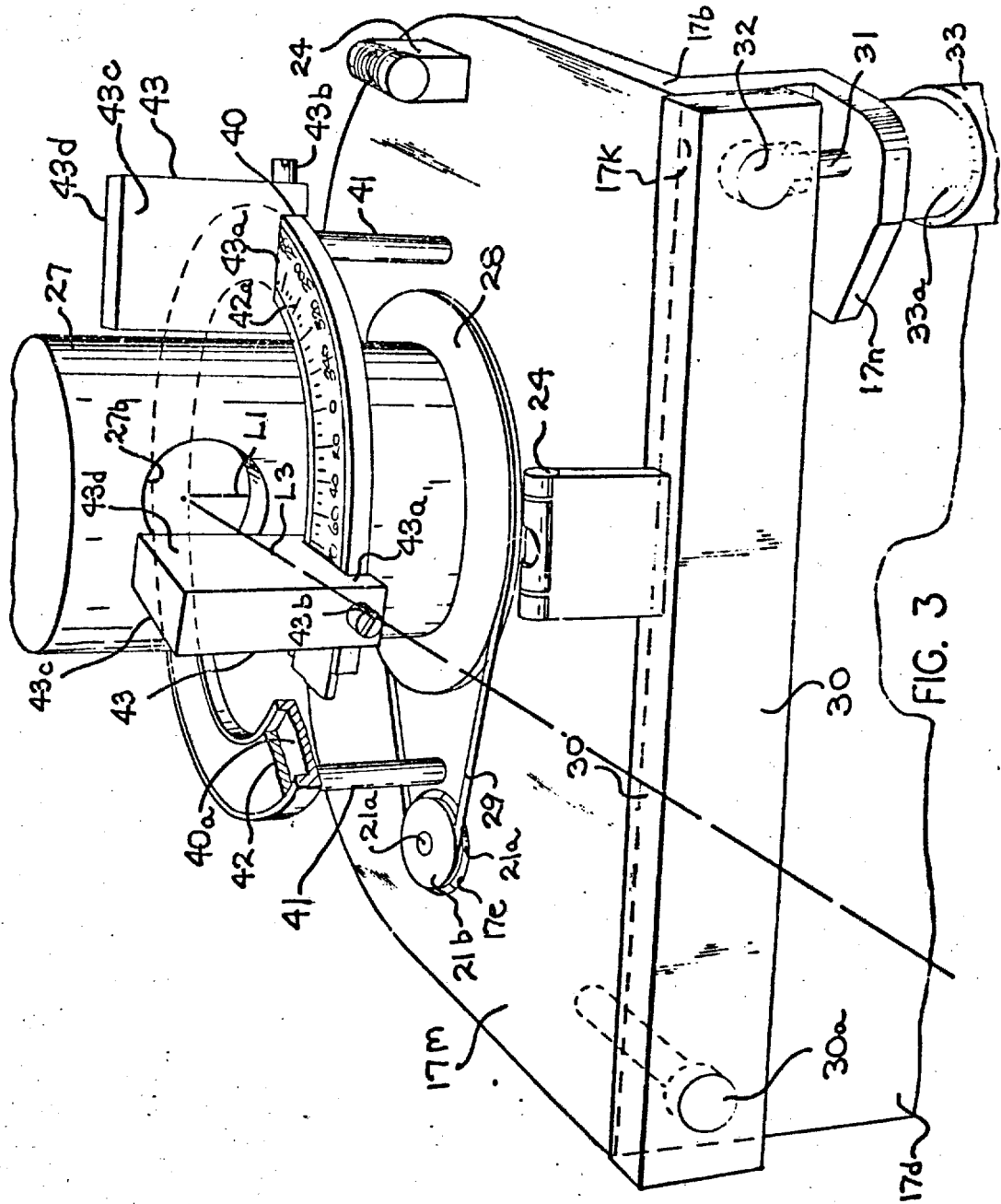

INVENTOR
ROBERT H. STUDEBAKER
BY W. A. Schaich &
Thomas A. Neenan
ATTORNEYS

Oct. 7, 1969

R. H. STUDEBAKER

3,471,234

LASER BEAM PROJECTOR FOR SURVEYING OPERATIONS

Filed June 8, 1966

4 Sheets-Sheet 4

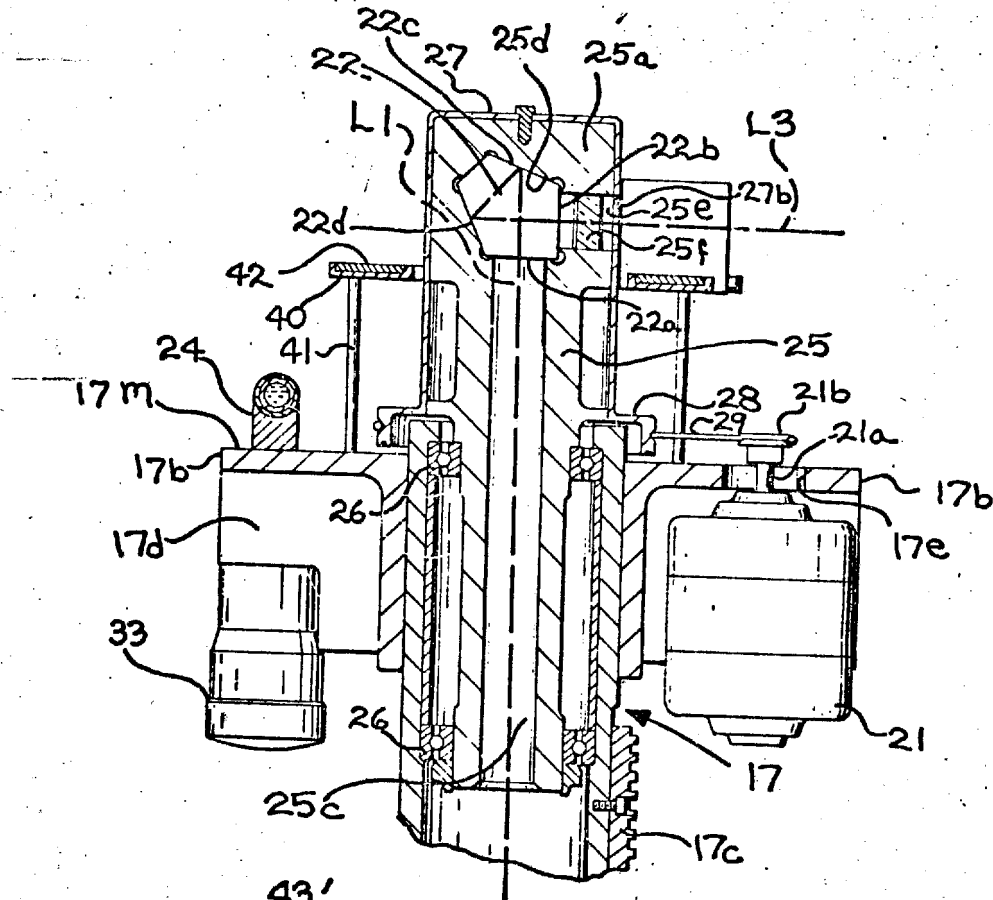

FIG. 4

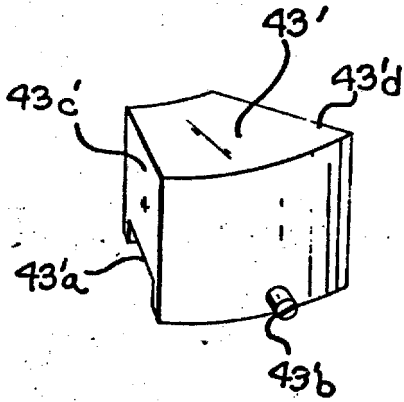

FIG. 6

INVENTOR
ROBERT H. STUDEBAKER
BY W.A. Schaich &
Thomas A. Melhan
ATTORNEYS

United States Patent Office

3,471,234

Patented Oct. 7, 1969

1

3,471,234

LASER BEAM PROJECTOR FOR SURVEYING OPERATIONS

Robert H. Studebaker, Dayton, Ohio, assignor to Process Equipment Company of Tipp City, Inc., a corporation of Ohio

Filed June 8, 1966, Ser. No. 556,018

Int. Cl. G01c 3/00, 5/00, 1/00

U.S. Cl. 356-3

8 Claims

ABSTRACT OF THE DISCLOSURE

This invention provides a method and apparatus for performing precise surveying operations relative to a selected reference point by utilizing a laser beam. A portable laser beam reference plane generator is provided which may be set up in precise alignment with a selected reference point and which produces a rotating laser beam sweeping over the adjacent terrain. The generator may be accurately adjusted to permit both elevation and angular displacements to be measured at any point within the area traversed by the rotating laser beam.

This invention relates to a precision surveying apparatus employing a laser beam as a reference plane, which plane may be horizontal or at any desired angle relative to the horizontal, and more particularly, to a portable laser beam reference plane generator which may be set up in precise alignment with a selected reference point on any type of terrain and conveniently and accurately adjusted to produce a laser beam rotating about an axis passing through such reference point.

In my copending application Ser. No. 468,821, filed July 1, 1965, now abandoned, and assigned to the assignee of this application, I have disclosed and claimed a method and apparatus for utilizing a generated laser beam sweeping through a preselected reference plane for determining the relative elevation with respect to the reference plane of any ground surface point within the effective range of such laser beam. As pointed out in such copending application, such system greatly facilitates surveying operations and may also be utilized to simultaneously control earth working operations of a plurality of grading machines, scrapers, mining equipment, or the like, each of which being provided with laser beam detector means and suitable control arrangements responsive to the laser beam for adjusting the elevation of the implement to maintain such implement at a preselected displacement relative to the laser beam reference plane, irrespective of the terrain variations.

In my copending application Ser. No. 474,684, filed July 26, 1965, now abandoned, and assigned to the assignee of this application, I have disclosed a specific structure for a tripod-mounter laser beam generator. I have now developed certain improvements in such construction which provide even greater convenience and accuracy in operating such laser beam generator and further permits the resulting laser beam to be utilized to not only determine elevation in surveying operations but also permits angular displacements to be accurately laid out or measured over any type of terrain.

More particularly, it is an object of this invention to provide a portable laser beam generator capable of producing a laser beam rotating about an axis characterized by the fact that the rotatable axis of the laser beam may be precisely aligned with a ground reference point.

Another object of this invention is to provide an improved method of surveying utilizing a rotating or oscillating laser beam.

A further object of this invention is the provision of

2

a rotatable laser beam generator wherein a shadow may be produced in the beam at any one or more of a plurality of precise angular locations around the rotational axis of the laser beam, thereby permitting the measurement or layout of angular displacements about the axis of the rotating laser beam.

Still another object of this invention is to provide a laser beam generator of the type producing a laser beam rotating in a plane, characterized by the provision of accurate mechanism for tilting the plane defined by the laser beam to assume a desired inclination with respect to the axis of rotation of the laser beam.

Other and further objects and advantages of this invention will become apparent to those skilled in the art from the following detailed description thereof, taken in conjunction with the annexed sheets of drawings on which a preferred embodiment of this invention is illustrated.

On the drawings:

FIG. 1 is a side elevational view of a planar laser beam generator constructed in accordance with this invention.

FIG. 2 is a sectional view taken on the plane A—A of FIG. 1.

FIG. 3 is an enlarged scale perspective view of the top portion of the laser beam generator of FIG. 1.

FIG. 4 is a partial vertical sectional view of the top portions of FIG. 1.

FIG. 5 is a schematic plan view illustrating the utilization of the laser beam generator of FIG. 1 in a surveying operation for accurately determining angular displacements.

FIG. 6 is a perspective view of a modified beam blocking member.

As shown on the drawings:

All of the elements of the laser beam generator shown in FIG. 1 which appear below the section line A—A are functionally identical to those disclosed and described in detail in my said copending application Ser. No. 474,684, filed July 26, 1965 and hence reference should be had to that application for a more detailed description of these elements. Briefly, there is provided a primary base or support member 10 which is of a circular platelike configuration and has a plurality of depending mounting brackets 11 welded around the periphery thereof to provide a pivotal mounting for the bifurcated ends of tripod legs 13. In this manner, primary base 10 may be supported by the tripod legs 13 in a roughly horizontal position on any terrain. Base 10 is further provided with a central depending circular boss 10a welded thereto and a similar boss 10b, formed in two semi-circular pieces is secured to the top surface of primary base 10 by a plurality of bolts (not shown). Bosses 10a and 10b are centrally apertured and together define a spherical segment internal bearing surface (not shown).

A secondary base element 15 is provided which constitutes a vertically extending hollow member. The lower end of secondary base member is enlarged and ground to produce an external spherical segment bearing surface (not shown) which is cooperable with the interior spherical bearing surface of the primary base member 10 to adjustably mount the secondary base element in a generally vertical position relative to the primary base 10.

Near the middle portion of the secondary base element 15, a radially projecting integral flange 15c is provided which overlies the primary base 10 beyond the perimeter of boss 10b. At equally spaced locations around the perimeter of flange 15c, a plurality of threaded apertures are provided which respectively receive the threaded ends of depending adjusting pins 16. The adjusting pins 16 are each provided with an enlarged hand grasping col-

3,471,234

3

lar 16b and a flat head portion 16c which contacts the top surface of primary base 10. It is therefore apparent that the adjusting pins 16 permit the vertical position of secondary base 15 to be accurately pivotally adjusted relative to the primary base or support 10 to assume either a true vertical position or a position at any desired inclination relative to the vertical, as indicated by means that will be hereafter described.

The top portion of secondary base 15 is axially slit to define two opposed clamping flanges 15f and a hand actuated clamping bolt 15e is provided to draw such clamping flanges 15f together. Additionally, a spur gear 15k is journaled between flanges 15f and is rotatable by a hand crank 15j for a purpose to be described.

As previously mentioned, secondary base element 15 is hollow and defines a vertically extending cylindrical bore 15a (FIG. 2) extending completely through the secondary base element. A tubular support or housing 17 is provided having a cylindrical portion 17a which is snugly but slidably insertable in the cylindrical bore 15a of the secondary base element 15. An axially extending rack gear 17c is secured to the outer wall of tubular support 17 and passes through flanges 15f and cooperates with spur gear 15k. A suitable axial slot (not shown) is provided in the secondary base element 15 to accommodate the rack gear 17c.

It is therefore apparent that the relative vertical position of the housing 17 with respect to the secondary base element 15 may be conveniently adjusted by rotating hand crank 15j and the housing 17 may then be locked in any selected vertical position relative to the secondary base 15 by tightening the clamping bolt 15e. Such adjustment, however, does not produce any deviation of the axis of tubular housing 17 relative to the axis of the bore of the secondary base element 15, hence, in any selected vertical position, the axis of the housing 17 is shifted relative to the vertical by manipulation of the adjusting pins 16.

In the lower portions of the tubular housing 17, a conventional laser beam source 18 is suitably mounted so that a collimated primary beam L1 produced by such laser source is upwardly directed and is coaxially aligned with the axis of housing 17. The laser beam source 18 may comprise any conventional gas laser such as the Model No. 5200 currently manufactured and sold by Perkin-Elmer Corporation of New Britain, Conn. The housing 17 is preferably formed from aluminum or any other metal which will shield the laser source 18 from ambient electrical disturbances and which will readily dissipate the heat generated by the laser source 18. Laser source 18 may be actuated by any source of electrical energy producing the required voltage and power.

I have observed that such laser beam sources actually produce two oppositely directed beams, one beam being, of course, the primary beam L1 and having the maximum intensity, but a secondary beam indicated at L2 (FIG. 1) is also emitted from the other end of such source in alignment with the primary beam L1. Secondary beam L2 is of substantially reduced intensity, yet quite visible to the eye of an observer. In accordance with this invention, the secondary laser beam L2 is utilized to assure the precise vertical alignment of the primary beam L1 with a selected ground reference point P. This can be very conveniently accomplished by providing a central aperture 17h in the bottom of housing 17 and covering such aperture with a transparent window 17j of glass or a plastic material that will readily transmit the laser beam L2.

Referring now particularly to FIG. 3, it will be observed that the top portion of the tubular housing 17 is provided with a radial enlargement indicated at 17b having a depending flange 17d along one side. An electric motor 21 is mounted on flange 17d in depending relationship to the enlargement 17b and has its shaft 21a projecting through an aperture 17e (FIG. 4) in the enlargement 17b and mounts a pulley 21b thereon. Within the top portions of the housing 17, a hollow hub 25 is rotatably journaled by suitable bearings 26. The upper portions of hub 25 project above the radial enlargement 17b and the top end 25a of hub 25 is solid. An inverted, cup-shaped cover 27 is mounted over the projecting portions of hub 25 and secured thereto by a bolt 27a. On the bottom edge of cover 27, a pulley 28 is welded and a belt 29 connects pulley 28 to the motor driven pulley 21b.

Near the top of hollow hub 25 an optical reflecting device 22 is mounted which is arranged to receive the upwardly directed primary laser beam L1 passing through the hub bore 25c and to reflect such beam in a fixed angular relationship to the direction of the incident beam, for example, at exactly 90° to the direction of the incident laser beam L1. Thus, the reflected beam L3 will be positioned in a fixed angular relationship, preferably 90°, with respect to the axis of tubular housing 17 and the bore axis of the secondary base element 15. Optical device 22 could be an accurate mirror positioned at a precise 45° angle with respect to the incident laser beam L1, but preferably comprises a device known as a pentaprism, one type of which is currently manufactured and sold by Brunson Instrument Company of Kansas City, Mo. and has the property of reflecting any incident light beam at exactly 90° to the direction of the incident beam. Hence any eccentricity in the rotation of the hub 25 due to bearing wear or misalignment will not change the angular relationship of the reflected beam L3 relative to the primary beam L1.

In the specific embodiment shown in the drawings, the hollow hub 25 is provided near its top with a recess 25d communicating with the hub bore 25c and corresponding in shape to the shape of the pentaprism 22. The recess 25d opens through the wall of the hub 25 so that the pentaprism 22 may be slidably but snugly inserted in such recess. A cover plug (not shown) is then inserted in the recess 25d to hold the pentaprism 22 in position. The pentaprism is of roughly pentagonal shape and is formed from optical quality glass. One side 22a of the pentaprism receives the incident laser beam L1 and another side 22b, which is perpendicular to the first side 22a, transmits the reflected laser beam L3. The other two opposed angular sides 22c and 22d of the pentaprism have a mirror coating applied to their outer surfaces, and these sides are accurately ground so that the incident beam L1 is internally reflected in the pentaprism 22 to follow the path indicated by the dotted lines to produce the final output beam L3, which will always be at exactly 90° to the direction of the incident beam L1. The hub 25 is, of course, provided with a radial aperture 25e to permit the reflected beam L3 to pass out of the hub. The cover 27 is provided with a suitable aperture 27b in its side wall aligned with the radial hub opening of 25e, and hence with the path of the reflected laser beam L3. Aperture 25e may be covered by a suitable inserted window 25f of glass or transparent plastic as desired.

The top surface 17m of the housing enlargement 17b is accurately ground to be precisely normal to the axis of housing 17, hence normal to the primary laser beam L1. A pair of mutually perpendicularly disposed fluid bubble level indicators 24 are then mounted on, or in a selected angular relationship with the ground top surface 17m and the indicating bubbles of such level indicators may be utilized to indicate when the surface 17m is exactly horizontal with respect to gravity or in a selected angular relationship therewith.

In accordance with this invention, one of the level indicators 24 is mounted on a sine bar 30. The sine bar 30 is snugly pivotally mounted at one end on a pivot bolt 30a which is threaded into the depending flat side 17d of the enlargement 17b. The other end of the sine bar is raised or lowered relative to the top surface 17m of housing enlargement 17b by a micrometer actuated rod 31 which abuts against a transverse pivot pin 32 journaled

formed on

3,471,234

5

the housing side 17d and such bracket is traversed by the micrometer rod 31 and mounts in depending relationship a conventional micrometer adjusting mechanism 33. Mechanism 33 is provided with conventional calibrations 33a which are graduated to indicate the angular displacement of the sine bar 30 relative to the ground top surface 17m, preferably in conventional surveying units of .01 ft. vertical elevation per 100 ft. of horizontal distance. Accordingly, the sine bar 30 may be adjusted by micrometer mechanism 33 to a zero position where the top surface 30b of the sine bar 30 is exactly parallel to the ground surface 17m of the housing enlargement 17b, or may be angularly displaced upwardly or downwardly relative to the ground top surface 17m (hence, relative to the axis of rotation of the laser beam L3) by a precise angular amount by operation of the micrometer mechanism 33.

The last improvement accomplished by this invention involves the provision of a support ring 40 which surrounds cover 27 and is positioned in coaxial relationship with respect to the axis of housing 17, hence in coaxial relationship with respect to the primary laser beam L1. Ring 40 is supported in parallel relationship to the top surface 17m by a plurality of posts 41 which are suitably secured to the ring 40 and to the top surface 17m of the housing enlargement 17b. The ring 40 is of shallow U-shaped configuration, thereby defining an annular track or channel 40a (FIG. 3). An indicating ring 42 is snugly but rotatably mounted in the channel 40a. Ring 42 is provided with angular graduations 42a on its top surface.

In accordance with this invention, one or more beam blocking members 43 are provided which may be detachably secured to the ring 40 at any desired horizontal angular position relative to the axis of the primary laser beam L1, assuming such laser beam to be vertical. Beam blocking members 43 are provided with a properly shaped recess 43a in their bottom portions to permit such members to be snugly but slidably supported on the ring 40. A radially disposed clamping screw 43b permits each block 43 to be locked to ring 40 at any desired angular position about the ring 40.

Preferably, one of the beam blocking members 43 is constructed to have a transverse width in the plane of the rotating laser beam L3 equal to the corresponding width or diameter of the laser beam L3. The radial sides 43c and 43d of each beam blocking member 43 are exactly radial with respect to the rotational axis of the laser beam L3. If desired, additional beam blocking members 43' (FIG. 6) may be provided whose cross-sectional configuration in the plane of the rotating laser beam correspond exactly to a fixed angle. In the case of the illustrated beam blocking member 43', the angle is 90°.

The improvements in the laser beam generator heretofore described contribute substantially to the flexibility and utility of the laser beam generator. For example, in all surveying operations, or operations involving the control of earthworking or analogous equipment by a laser beam, there has to be first located in the working area one or more reference points whose elevation is precisely known. These reference points are commonly indicated by a stake driven into the ground with an X on the top of the stake indicating the precise reference point. It is, of course, desirable that the rotating laser beam L3 be aligned so that its axis of rotation passes precisely through the desired reference point. This is accomplished with the utmost dispatch by permitting the secondary laser beam L2 to project out of the bottom of housing 17 to impinge on the stake. Hence in setting up the laser beam generator, the transit legs will be adjusted so that the secondary laser beam L2 is observed to be incident upon the center point of the reference marking on the top of the reference stake.

In many surveying operations, it is desirable that a horizontal line be laid out at an exact angular relationship relative to another line. This may be conveniently accomplished by the use of the laser beam generator

6

Referring to FIG. 5, let us assume that it is desired to lay out a line extending from the reference point P at exactly 90° to another line passing through the reference point. A beam receiving surveying rod 50, of the type described in detail in my copending application Ser. No. 532,944, filed Mar. 9, 1966 and assigned to the assignee of this application, is then set up at any desired distance away from the reference point along the known line and vertically adjusted to receive the laser beam L3. One of the beam blocking members 43 is then moved around ring 40 until the signal generated by the receiver on surveying rod 50 is interrupted. At this position the surveying rod 50 lies exactly in the shadow of the beam produced by the beam blocking member 43. Such member 43 is locked in this position on ring 40 by screw 43b. The second beam blocking member (or the first one, if desired) is then positioned exactly 90° away from the position of the first blocking member, as indicated by the graduations 42a. The surveying rod 50 is then moved by the rodman until it lies in the beam shadow S' produced by the second beam blocking member 43, and the line drawn between the reference point and the second location of the rod 50 will be exactly 90° with respect to the known line. Of course, instead of utilizing two beam blocking members 43, the single beam blocking member 43' having an angular extent of 90° could be mounted on the support ring 40. Other utilizations of the beam blocking members for detecting or laying out horizontal angular relationships will be readily apparent to those skilled in the art.

At any time it is desired to move the rotating laser beam L3 in a plane that is inclined by a known amount of degrees relative to the horizontal, the sine bar 30 and micrometer adjusting mechanism 33 may be employed. It is only necessary to set up the laser beam generator so that the sine bar 30 is generally perpendicular to the horizontal axis about which the tipping of the resulting laser beam plane is desired. Micrometer mechanism 33 is then actuated to displace the sine bar 30 by the desired amount of angular inclination. Thereafter, the adjusting pins 16 are operated to bring both bubble level indicators 24 to their level indicating positions. The resulting plane through which the rotating laser beam L3 is swept will then be exactly parallel to the top surface 30a of the sine bar 30, and hence will be inclined relative to the horizontal by the amount indicated by the setting of micrometer mechanism 33.

It will be understood by those skilled in the art that many of the terms utilized in this specification and claims are relative. Thus, in describing the invention, emphasis has been directed to conventional surveying operations wherein the rotating beam is moving in either a horizontal plane or a plane inclined at a slight angle to the horizontal. Laser beam generators embodying this invention may be applied to effect surveying measurements or utilized as a surveying reference plane for structures or operations requiring a vertical reference plane. In this case, the axis of rotation of the rotating laser beam would be generally horizontal, and supports other than the conventional tripod legs would have to be provided for the primary base member 10. Furthermore, for lack of an adequate generic term, I have employed in the claims the term "surveying reference apparatus." A device embodying this invention may obviously be utilized for setting up a laser beam reference plane for surveying operations, but the same plane may be advantageously utilized for controlling the vertical movements of the working tool of various types of earthworking implements; hence, the term "surveying reference" is intended to include all utilizations of the reference plane established by the rotating laser beam.

It is therefore apparent that a laser beam generator incorporating the described improvements may be quickly, conveniently and accurately set up on any terrain and conveniently adjusted to produce a laser beam rotating or exactly aligned

3,471,234

7

with a known reference point. The elevation of the resulting laser beam plane may be conveniently adjusted and the inclination of the resulting laser beam plane relative to the horizontal may be accurately and conveniently adjusted to any desired angular relationship. Lastly, angular displacements may be laid out, or the angular distance between two unknown points on the terrain relative to a reference point may be quickly and accurately determined.

As will be evident to those skilled in the art, modifications of this invention can be made in the light of the foregoing disclosure without departing from the scope of the appended claims.

I claim:

1. Laser beam surveying apparatus comprising:

- (1) means for rotating a laser beam about a vertical reference axis;
- (2) an annular ring supported in coaxial relationship with said reference axis and axially spaced from the laser beam;
- (3) At least one beam-blocking member mountable on said ring in any selected angular position thereon, said beam-blocking member intersecting said laser beam and having a width dimension in the plane traversed by the laser beam at least equal to the width of the laser beam, thereby creating a void in the resulting laser beam reference plane at any selected angular position about said reference axis; and
- (4) arcuate scale means for indicating the angular position of said beam-blocking member.

2. The apparatus defined in claim 1 wherein said arcuate scale means comprises a second ring bearing degree graduations, said second ring being rotatable relative to said first mentioned ring and coaxial therewith.

3. Apparatus for surveying angular relationships about a ground reference point comprising:

- (1) means for rotating a laser beam about a vertical axis passing through the ground reference point;
- (2) a horizontal annular ring supported in coaxial relationship with said vertical axis and vertically spaced from the laser beam;
- (3) at least one beam blocking member mountable on said ring in any selected angular position thereon, said beam blocking member intersecting said laser beam and having a cross-sectional configuration in the plane traversed by the laser beam corresponding to the desired angle, thereby creating an angular void in the resulting laser beam reference plane at any selected angular position about the ground reference point.

4. A method of utilizing a laser beam as a surveying reference comprising the steps of:

- (1) selecting a reference point in the area to be surveyed;
- (2) positioning a laser beam source, of the type producing two oppositely directed laser beams, in a position where the beams are vertical and the downwardly directed one of said beams impinges on said reference point;

8

(3) reflecting the upwardly directed beam at a known angle to the vertical; and

(4) detecting the reflected beam at a point horizontally spaced from said reference point.

5. The method defined in claim 4 wherein said reflected laser beam is continuously rotated or oscillated about the vertical axis of the originally generated laser beam, thereby defining a surveying reference plane having a known elevational relationship to said reference point.

6. A laser beam generator comprising a primary support structure, a laser beam source producing two oppositely directed laser beams, a hollow tubular housing constructed and arranged to receive said laser beam source therein with said laser beams respectively directed parallel to the housing axis, means for mounting said housing on said support in a generally vertical position, said last mentioned means including means for angularly adjusting the position of said housing to precisely position both laser beams in a true vertical position, whereby the downwardly directed beam impinges on the ground or other reference surface to permit vertical alignment of the downwardly directed beam with a desired reference point, an optical device capable of reflecting an incident laser beam at a known angle, means for rotatably mounting said optical device in the path of said upwardly directed laser beam, whereby rotation or oscillation of said optical device causes the reflected laser beam to sweep through a plane at a known angle to the true vertical.

7. The apparatus of claim 6 plus means for adjusting the vertical position of said optical device relative to said primary support.

8. Laser beam surveying apparatus comprising: (1) means for rotating a laser beam transversely about a vertical reference axis; (2) a beam-blocking member; (3) means for positioning said beam-blocking member to intercept said beam at any selected angular position around said vertical axis, thereby creating a void in the resulting laser beam reference plane at any selected angular position about said reference axis.

References Cited

UNITED STATES PATENTS

| | | | |
|-----------|---------|---------------|----------|
| 368,308 | 8/1887 | Richardson | 33-72 |
| 1,922,791 | 3/1930 | Bumpus | |
| 2,661,653 | 4/1951 | Castiglia | 88-2.2 X |
| 3,266,014 | 8/1966 | Leotta | 240-49 X |
| 3,279,070 | 10/1966 | Blount et al. | 33-46.2 |
| 3,335,285 | 8/1967 | Gally et al. | |

RONALD L. WIBERT, Primary Examiner

J. ROTHENBERG, Assistant Examiner

U.S. Cl. X.R.

33-72; 331-94.5; 356-138

July 7, 1970

G. PRADEL ET AL

3,519,829

OPTICAL SYSTEM FOR RADIATION SENSITIVE RANGEFINDER

Filed Oct. 10, 1967

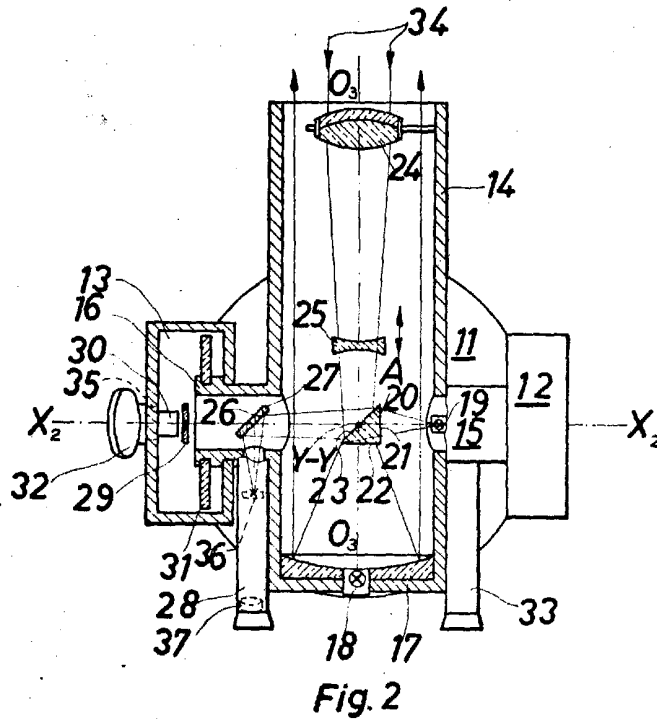
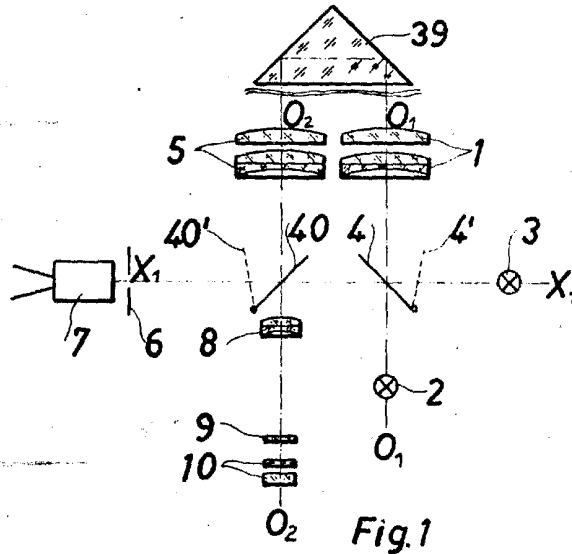

INVENTOR
George Pradel
Roy Egan
Klaus Richter
BY
ATTORNEY

1

2

3,519,829

**OPTICAL SYSTEM FOR RADIATION
 SENSITIVE RANGEFINDER**

Georg Pradel, Heinz Richter, and Rolf Roder, Jena, Germany, assignors to VEB Carl Zeiss Jena, Jena, District of Gera, Germany

Filed Oct. 10, 1967, Ser. No. 674,710

Int. Cl. G01c 3/08

U.S. Cl. 250—216

6 Claims

ABSTRACT OF THE DISCLOSURE

An electro-optical rangefinder has two optical systems and two light-sources. The one light-source through one of the optical systems emits intensity-modulated invisible light for measurement. The other light-source emits visible light and together with the other of the two optical systems makes up into a searchlight. Said other light-source lies at such a focus of said one optical system as corresponds to the medial wave-length of the light it emits. To the optical system not emitting visible light is coordinated an eyepiece for visual reception of the visible light. The two optical systems may be coaxial with each other.

This invention relates to electro-optical rangefinders comprising a radiation source emitting invisible light of modulated intensity and two optical systems for respectively transmitting and receiving this light.

Some known electro-optical rangefinders have a radiation source emitting visible light the beam of which is modulated in intensity and then transmitted through an optical system that serves at the same time for spotting a distant reflector. Other such rangefinders with radiation source emit and receive invisible light. Locating a remote reflector by means of an electro-optical rangefinder of that kind presents considerable difficulties, which can only be obviated by the simultaneous use in the measuring process of a separate search light. This separate searchlight and the orientation it is required to impart to the electro-optical rangefinder, incur considerable material expenditure and complicate the measuring process.

The present invention aims at providing an electro-optical rangefinder using invisible light for measuring which is equipped with a searchlight that involves only a minimum of material and technical complexity.

To this end the invention consists in an electro-optical rangefinder of the foregoing kind wherein a light-source emitting visible light is located at such a focus of one of the optical systems as corresponds to the medial wave-length of its light beam. If this optical system is a surface mirror, the position of the focus is of course independent of wave-length. On principle, the light-source supplying visible light may be conjugate to the transmitting or to the receiving optical system of the electro-optical rangefinder. However, it is very often advisable to coordinate the source of visible light to the optical system emitting the intensity-modulated beam. A further simplification in the set-up of such rangefinders can be obtained by providing that the optical system not serving as searchlight is in the form of a sighting telescope. Advantageously the beam of the light-source emitting visible light and that of the radiation source emitting invisible light are so directed to a selectively silvered surface that this surface reflects to the transmitting optical system either the invisible or the visible light and lets the other pass unobstructed.

Advantageously the transmitting and the receiving optical system have a common optical axis. According to a further feature of the invention, both systems are jointly

rotatable about a horizontal and a vertical axis, both rotations being measurable.

In order that the invention may be more readily understood, reference is made to the accompanying drawings which illustrate diagrammatically and by way of example two embodiments of an electro-optical rangefinder, and in which:

FIG. 1 shows the optical parts of an embodiment with separate optical systems for transmitter and receiver, and FIG. 2 shows the optical parts of another embodiment with coaxial optical systems for transmitter and receiver.

In the embodiment shown in FIG. 1, a light-source 2 emitting visible light and a radiation source 3 emitting invisible light are located respectively in two foci of a transmitting optical system 1. The source 2 lies in the optical axis O_1-O_1 of the system 1. The source 3 lies at one side of this axis, its light being directed to the system 1 by means of a folding mirror. The mirror 4 is so tiltable into two positions that a remote reflector 39 receives either visible spotlight (position 4') or invisible measuring light (position 4).

A receiving optical system 5, equal to the transmitting system 1, has an optical axis O_2-O_2 parallel to the axis O_1-O_1 . The focus of the system 5 lies in a diaphragm 6 coordinated to an electric receiver 7. The modulated invisible light of the radiation source 3 reflected by the remote reflector, traverses the optical system 5, is reflected by the remote reflector, transverses the optical system 5, is reflected at a folding mirror 40, arrives at the diaphragm 6 outside the optical axis O_2-O_2 and enters the receiver 7. The center of the diaphragm 6 and that of the radiation source 3 lie in an axis X_1-X_1 which is at right angles to the optical axes O_1-O_1 and O_2-O_2 and is the common axis of rotation of the two systems 1 and 5.

The optical axis O_2-O_2 contains a focussing lens 8, a graduated plate 9 and an eyepiece 10, which together with the optical system 5 make up into a sighting telescope. If the mirror 4 and the mirror 40 respectively assume the positions 4' and 40', the light of the light-source 2 is directed through the optical system 1 and reflected by the remote reflector, whereupon it enters the sighting telescope 5, 8, 9, 10 and, if accurately oriented and focussed, forms on the plate 9 an image of the reflector. When, and not before, the image of the reflector lies at the center of the graduated plate 9, the folding mirrors are to be tilted into the positions 4 and 40, whereupon the distance can be measured by means of the receiver 7 and the modulated light striking it, this light being converted for range display. The simultaneous tilting of the two mirrors may be operated by a suitable mechanism.

In the embodiment shown in FIG. 2 of the drawings, two supports 12 and 13 are mounted on an alidade 11 rotatable about an axis $Y-Y$ at right angles to the plane of the drawing. A telescope 14 is rotatable about an axis X_2-X_2 by means of two hollow trunnions 15 and 16 extending into the supports 12 and 13. The telescope 14 contains a concave mirror 17 for light projection. A radiation source 18 supplying modulated invisible light is provided near the apex of the mirror 17. A visible-light source 19 is in the trunnion 15 and the invisible-radiation source 18 are both located at foci of the concave mirror 17. A right-angled prism 20 is so disposed in the telescope 14 that its cathetus surfaces 21 and 22 are respectively conjugate to the light-source 19 and the radiation source 18. The cathetus surface 22 is selectively silvered, so that the divergent light rays from the radiation source 18 are reflected to the concave mirror 17. The divergent rays of the light-source 19 are reflected by the hypotenuse surface 23 in the prism 20. They traverse the selectively silvered cathetus surface 22 and arrive at the concave mirror 17, which directs them as a beam of parallel rays

3,519,829

3

to a remote reflector similar to the reflector 39 of FIG. 2. The light-source 19 and the radiation source 18 can alternately be switched on and off.

The telescope 14 also contains an optical receiving system comprising an objective 24 and a focussing lens 25, the optical axis O_3-O_3 of this system coinciding with that of the concave mirror 17. Whereas the objective 24 is rigidly connected to the telescope 14, the focussing lens 25 in the telescope is displaceable along the directions of the arrow A.

The trunnion 16 contains a plane mirror 26 which is rotatable about an axle 27 at right angles to the plane of the drawing. A tube 28 fast with the trunnion 16 contains a graduated plate 36 and an eyepiece 37 which together with the optical system 24, 25 make up into a sighting telescope.

The support 13 contains a diaphragm 29 conjugate to a photoelectric receiver. The diaphragm 29 and the receiver 30 are so located that their centers lie in the axis X_2-X_2 . The diaphragm 29 and the cross line on the graduated plate 36 in the tube 28 lie within the image distance of the optical system 24, 25. A beam 34 of parallel light rays reflected by the remote reflector traverses the optical system 24, 25 and is transmitted as a converging beam to the hypotenuse surface 23 of the prism 20, whence this beam is directed either to the plane of the graduated plate 36 or to that of the diaphragm 29, depending on whether the light is of the visible or the invisible kind and according to the respective position of the mirror 26. A range is determined by the modulated light that emanates from the radiation source 18 and which in a similar manner to FIG. 1 is so reflected from the remote reflector as to travel through the optical system 24, 25, 23 to the plane of the diaphragm 29, and by the receiver 30 which the impinging light signal causes to display the range.

In the embodiment shown in FIG. 2, the light-source 19 emits visible light via the prism 20 and the concave mirror 17, which serves as spotlight projector. The light returned by the remote reflector travels by way of the objective 24, the focussing lens 25, the hypotenuse surface 23, the mirror 26 and arrives in the optical system in the tube 28, which serves as sighting telescope.

In the support 13, a vertical graduated dial 31 is fast with the trunnion 16. The readings on the dial 31 can be taken by means of a mirror 32 on the support 13, an aperture 35 in the support 13 and a reading microscope 33 fast with the trunnion 15. The microscope 33 can also be used for reading the values of the rotations of the telescope 14 about the axis Y-Y.

4

The embodiments of the invention particularly described are represented merely as examples of how the invention may be applied, many modifications being possible in the construction and relative positions of the optical systems and the light-sources.

We claim:

1. An electro-optical rangefinder comprising: a radiation source supplying invisible modulated light, an optical system for transmitting said modulated light subsequently to reflection by a remote reflector, a photo-electric receiver receiving said modulated light, a light-source supplying visible light, said light-source being disposed at such a focus of one of said two optical systems as corresponds to the medial wavelength of the visible light, said one optical system emitting the visible light, the other of said optical systems receiving the visible light reflection of same at said reflector, and an eyepiece system coordinated to the optical system receiving the visible light, said eyepiece system being for visual observation of the visible light reflected by said reflector.
2. An electro-optical rangefinder as claimed in claim 1, wherein the optical system traversed by said modulated light is in the form of a sighting telescope.
3. An electro-optical rangefinder as claimed in claim 1, wherein the source of visible light is coordinated to the optical system emitting the intensity-modulated beam.
4. An electro-optical rangefinder as claimed in claim 1, wherein the optical systems have a common optical axis.
5. An electro-optical rangefinder as claimed in claim 1, wherein said reflector is coordinated to a right-angled prism, the cathetus surface of the prism which faces the reflector being selectively silvered.
6. An electro-optical rangefinder as claimed in claim 5, wherein both systems are jointly rotatable about a horizontal and a vertical axis.

References Cited

UNITED STATES PATENTS

| | | | | |
|-----------|---------|-------------|-------|-----------|
| 2,966,090 | 12/1960 | Scholdstrom | ----- | 356-5 |
| 3,035,176 | 5/1962 | Kis et al. | ----- | 365-3 X |
| 3,146,446 | 8/1964 | Novitsky | ----- | 250-220 X |

WALTER STOLWEIN, Primary Examiner

U.S. Cl. X.R.

356-4

50

[72] Inventor Ludwig Leitz
Wetzlar, Germany
[21] Appl. No. 687,650
[22] Filed Dec. 4, 1967
[45] Patented Sept. 22, 1970
[73] Assignee Ernst Leitz GmbH,
Wetzlar, Germany
[32] Priority Dec. 6, 1966
[33] Germany
[31] L 55,208

| [56] References Cited | | UNITED STATES PATENTS | |
|-----------------------|--------|-----------------------|--------|
| 1,847,010 | 2/1932 | Koppe..... | 355/61 |
| 2,968,994 | 1/1961 | Shurcliff..... | 350/46 |
| 2,983,208 | 5/1961 | Sapp..... | 95/44 |
| 3,185,059 | 5/1965 | Durst..... | 95/44 |
| 3,270,647 | 9/1966 | Jakob et al..... | 95/44 |
| 3,274,914 | 9/1966 | Biedermann et al..... | 95/44 |

Primary Examiner—John M. Horan
Assistant Examiner—Richard L. Moses
Attorneys—Krafft and Wells

[54] PHOTOELECTRIC PRECISION CAMERA RANGE FINDER WITH OPTICAL VERIFICATION
6 Claims, 4 Drawing Figs.

[52] U.S. Cl..... 95/44,
350/46, 355/55, 356/4
[51] Int. Cl..... G03b 3/00
[50] Field of Search..... 95/44, 44C,
45; 355/55, 61; 350/46, 76, 77; 353/101; 356/4

ABSTRACT: A range finder device for cameras comprising an optical range finder for coarse visual control of the camera range setting as well as a photoelectric range finder for a precise reading of the range setting, the optimal setting being indicated when both readings simultaneously indicate their optimal value. The optical range finder is either of the triangulation type, split image type, or of the ground glass type, while the photoelectric range finder uses two photo-resistors in a differential balance type circuit supplied by an AC-current. The arrangement is suitable for adaptation to "range finder" cameras as well as to single lens reflex cameras.

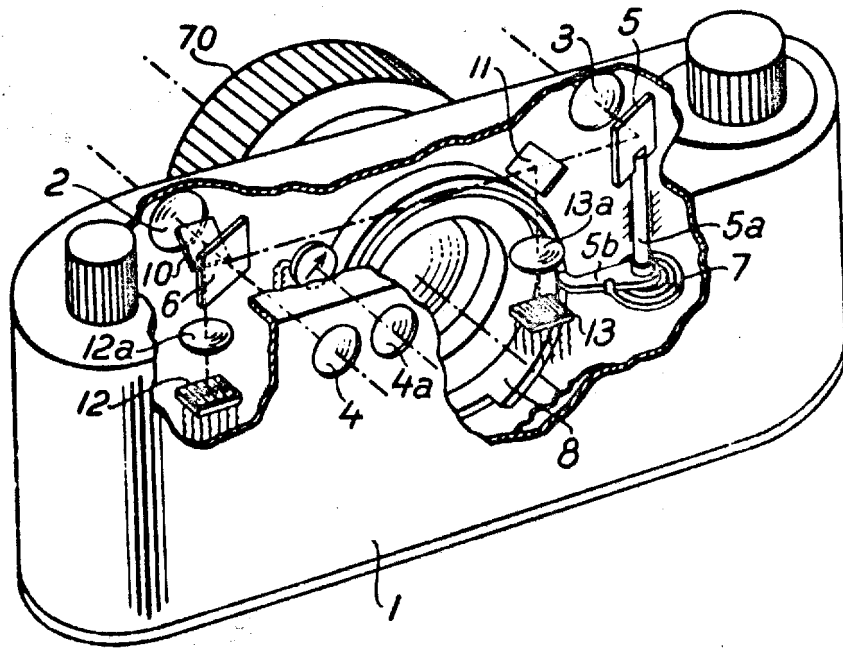

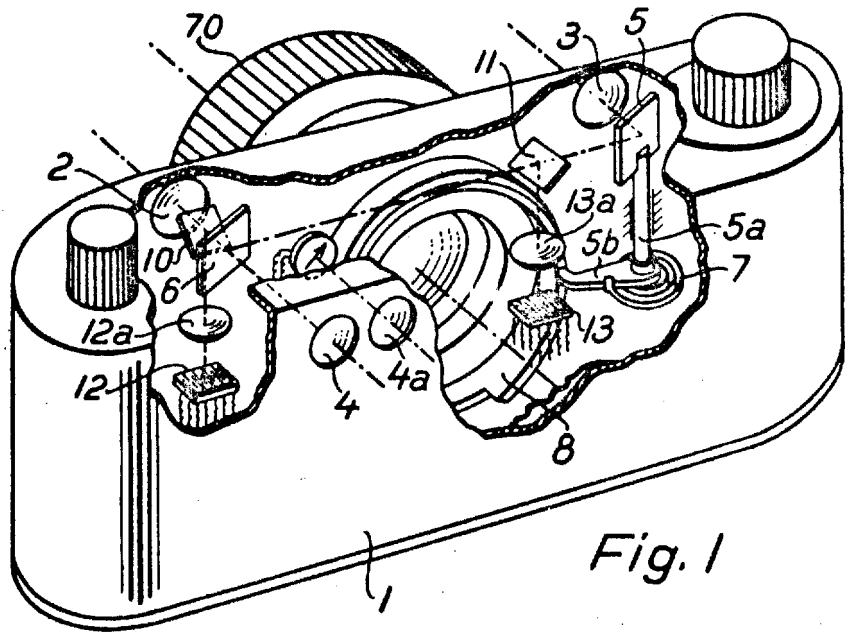

Fig. 1

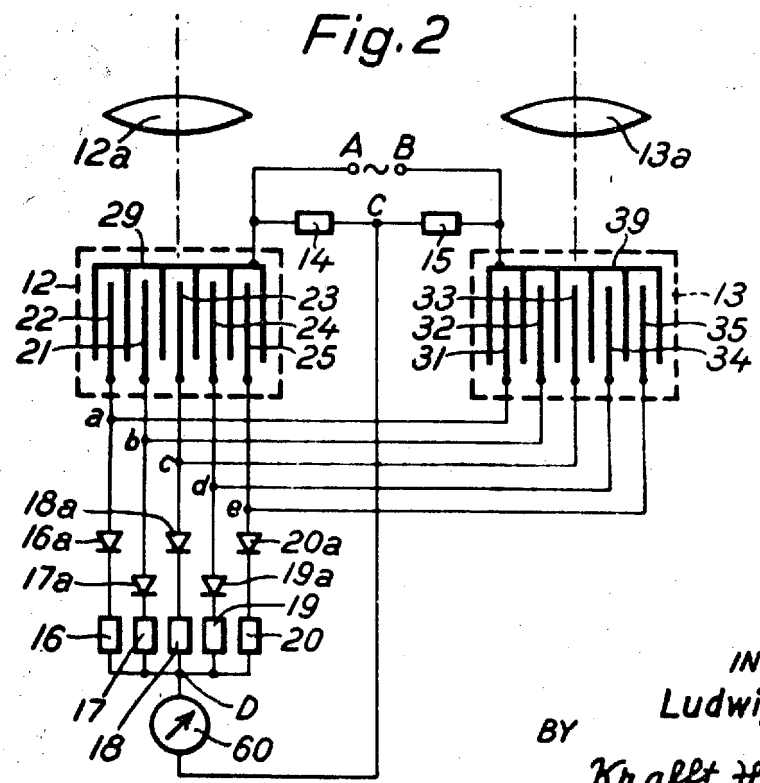

Fig. 2

INVENTOR
Ludwig Leitz
 BY *Kraft & Wells*
 ATTORNEYS

Patented Sept. 22, 1970

3,529,528

Sheet 2 of 2

Fig. 3

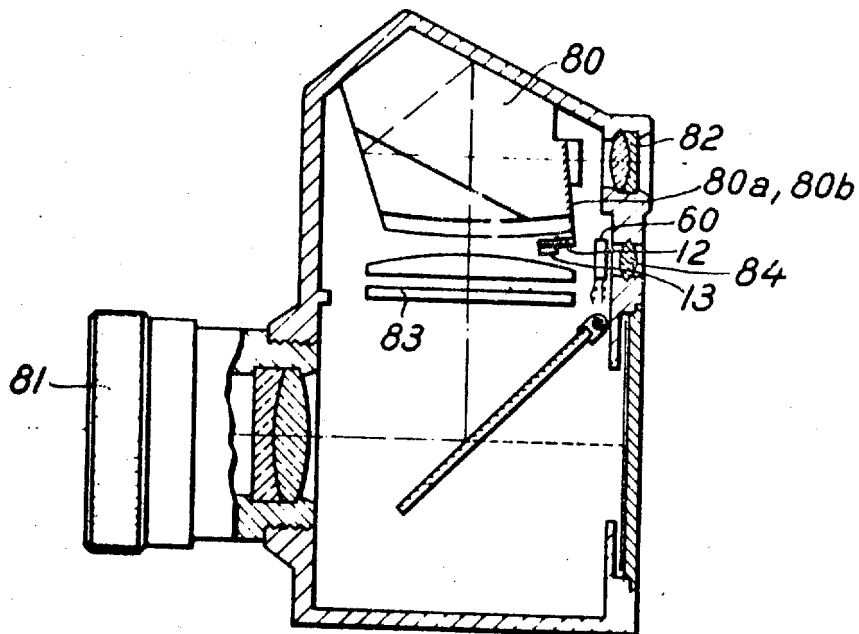
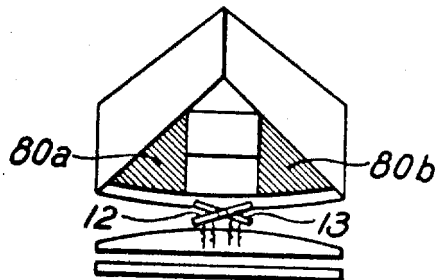

Fig. 3a



INVENTOR
Ludwig Leitz
BY Kraft & Wells

1

PHOTOELECTRIC PRECISION CAMERA RANGE FINDER WITH OPTICAL VERIFICATION

CROSS-REFERENCE TO RELATED APPLICATIONS

Reference is made to applicant's co-pending application Ser. No. 686,369, filed Nov. 29, 1967, now U.S. Pat. No. 3,529,527.

BACKGROUND OF THE INVENTION

1. Field of the Invention

The present invention relates to range finding devices in photographic cameras, and more particularly to photoelectric range finding devices.

2. Description of the Prior Art

It is well known to those skilled in this particular art to guide the two light beams of, for example, a coincidence-type range finder to two photoelectric receivers. These receivers consist each of an arrangement of elongated photosensitive elements on which the light beams are simultaneously incident. An electric circuitry is provided for comparing the voltage difference of the signals generated in the elements by said two light beams, which means comprise a measuring instrument having an indicating needle. Range finding is accomplished by adjusting the optical elements of the range finder until the deflection of the needle of the measuring instrument is a minimum.

However, it was found that minimum needle deflection may result, even though the range finder has not yet been adjusted to the correct distance. Such erroneous adjustments occur primarily when the objects whose distance is measured are surrounded by an object space of periodic structure containing a plurality of similar objects located side-by-side, such as, for example, a row of trees or of uniformed persons. From such periodic structure equal light fluxes can originate which may not come from the object itself but from other object space portions, from which by sheer coincidence a light flux may emerge which equals in intensity the light flux impinging on the photoelectric receivers from the object. This, however, may not be noticed by the operator.

It is therefore an object of the present invention to provide a range finder device where the degree of adjustment is indicated as a photoelectric precision reading as well as in an optical range finding image, so as to avoid erroneous adjustments.

This object is attained by combining in a photographic camera a photoelectric precision range finder and an optical range finder. The latter then serves as a coarse adjustment indicator, while the photoelectric reading is used only for the fine adjustment reading within a range where the above-described problems of spatial periodicity is no longer present. During the initial adjustment, the object itself is observed through a split-image-type, or coincidence-type, or ground-glass-type optical range finder. The subsequent "corrective" fine adjustment is made while observing the reading of the photoelectric range finder, which may be shown by a moving instrument needle. The basic idea of the new device is to permit a coarse lens setting sufficiently close to the correct position by means of the optical range finder so that the axes of the two range finder beams are already generally directed to the object to be measured, consequently eliminating the danger of one of the photoelectric receivers being exposed to light rays of object intensity, which actually do not result from the object.

DESCRIPTION OF THE DRAWINGS

The invention will be more fully comprehended from the following description when taken in conjunction with the accompanying drawings wherein

FIG. 1 is a perspective sectional view of a range finder camera in which an optical and a photoelectric range finding device are incorporated,

FIG. 2 shows schematically a wiring diagram of the photoelectric range finder,

2

FIG. 3 is a sectional view of a single lens reflex camera with a photoelectric range finder, showing a different embodiment of the invention;

FIG. 3a is a partial rear view of the penta prism and the photoelectric receivers of the embodiment of FIG. 3.

DESCRIPTION OF THE PREFERRED EMBODIMENTS

Referring now to FIG. 1 the camera 1 is provided with an optical range finder of known design. This range finder comprises two objective lenses 2 and 3 and one ocular 4. Objective lens 2 and ocular 4 form at the same time the view finder of the camera.

In the path of the view finder light beam between objective lens 2 and ocular 4 there is disposed a semi-transparent mirror 6 at an angle of 45° to the optical axis. By said mirror the second range finder light beam impinging from objective lens 3 via a mirror 5 is reflected into the ocular 4. Mirror 5 is mounted on a pivotable shaft 5a which is in rigid connection with a lever 5b. A spring 7 exerts a force on lever 5b thereby keeping the free end portion of lever 5b in operative connection with a cam 8. The latter is part of the camera objective lens 70 and is rotatable with said lens for distance adjustment purposes.

The above described elements by themselves constitute a known optical range finder of the split-image type or coincidence-type.

The camera 1 is further provided with two semi-transparent mirrors 10, 11 which are arranged, one in the path of each range finder light beam. By said mirrors 10, 11 a portion of each beam is reflected to separate photoelectric resistors 12, 13 through field lenses 12a, 13a. The photoelectric resistors are elements in a Wheatstone bridge circuit, as shown in FIG. 2, which further comprises the ohmic resistors 14, 15, further ohmic resistors 16, 17, 18, 19, 20 and current rectifiers 16a, 17a, 18a, 19a, 20a.

The photoelectric resistors are of identical design, shape and electrical properties. Each one consists of signal electrodes 21, 22, 23, 24, 25 and 31, 32, 33, 34, 35 respectively which are electrically separated from each other and are arranged in parallel. One common electrode 29 and 39 respectively is provided in each photoelectric resistor. The signal electrodes 21 through 25 and 31 through 35 are connected in pairs and each pair is connected to a series arrangement of one current rectifier 16a through 20a and one ohmic resistor, the ohmic resistors being connected in parallel to terminal D in the circuit.

The Wheatstone bridge is supplied with an AC current at the terminals A, B and the measuring instrument 60 is connected between the terminals D and C. The field lenses 12a, 13a are arranged in front of the photoelectric resistors.

The above described elements constitute a photoelectric range finder which functions in the following manner: If, on the photoelectric resistor 12, light beams are incident from the details of a certain object to be measured, the different photosensitive elements between the signal electrodes 21 through 25 will assume different resistance values according to the intensities of said light beams originating from said object details. Equal resistance values will be assumed by the photosensitive elements of resistor 13 if the pivotable mirror 5 in front of the resistor 13 is adjusted to a position wherein it reflects on the resistor 13 light beams emitting from the same object details as the light beams which are incident on the resistor 12. Under this condition of adjustment the bridge is balanced. At the terminals "a" through "e" half of the supply voltage can be measured. If, however, the object details imaged on both photoelectric resistors 12, 13 do not coincide, the voltage of at least one of the terminals "a" through "e" will be different from the half supply voltage. The current flowing through this terminal causes the needle of the measuring instrument 60 to be deflected. As is well known to those skilled in the art, range finding with photoelectric range finders is accomplished by directing the one of the photo-

elec Approved For Release 2009/04/10 : CIA-RDP81-00120R000100010021-3] in said camera rigidly arranged to the object to be measured. Then the pivotable optical elements in front of the second photoelectric resistor are pivoted until the needle deflection in the measuring instrument is a minimum. The position of the pivotable optical elements can be read against a scale which may be calibrated in distance units, e.g. in feet or meters.

The novel range finding device according to the invention is operated in two steps, by first adjusting the camera objective lens 70 by manually rotating said lens while viewing the image of the optical coincidence-type or split image-type range finder through ocular 4. After the objective lens 70 has thus been set coarsely to the object distance, the second step, which is the corrective fine adjustment of the objective lens to the object distance, is performed also by manually rotating lens 70, however, this time while observing the deflection of the needle of instrument 60, for example, through an auxiliary ocular 4a.

Emphasis is put on the fact that the novel range finding device is by no means limited to those cameras which in the art usually are termed "range finder" cameras. The new device can equally advantageously be employed with so-called single lens reflex cameras, if said cameras are additionally provided with a photoelectric range finding device as described above.

Particularly satisfactory results are obtained if the photoelectric resistors 12 and 13 are disposed in the place where in applicant's co-pending application Ser. No. 686,569, filed Nov. 29, 1967, the deviating wedges are located. FIGS. 3 and 3a show the resistors 12 and 13 arranged to the rear side of the camera and beneath the entering surface of penta prism 80. In this place the resistors are particularly adapted to be illuminated by light beams from large aperture image portions of the objective lens 81, after reflection of said beams from the silvered and inclined rear surface portions 80a and 80b of the penta prism 80. The photoelectric range finder incorporated in the single lens reflex camera makes thus use of a considerably enlarged base line in substantially the same manner as the optical coincidence-type or split image-type range finder which is disclosed in my above-mentioned co-pending application.

Below the main ocular 82 the camera has a second ocular 84 through which the photoelectric indicator 60 can be observed. The electric circuitry is the same for both embodiments shown.

Range finding with a single lens camera as illustrated in and described with reference to the FIGS. 3 and 3a is accomplished in much the same way as is done with range finder cameras. It involves an initial coarse adjustment of the lens 81 to the object distance while viewing an intermediate image of the object through the ocular 82 on the viewing screen or ground glass 83, followed by a "corrective" fine adjustment by observing the needle deflection in the instrument 60 through ocular 84.

Instead of being provided with the resistors 12, 13 the reflex camera may of course have a conventional central split image range finder comprising two deviating wedges in the central ground glass or viewing screen portion. The two bundles of light emerging from the wedges may be divided into two portions each, with one portion of each bundle being reflected to the ocular and the other portions being conducted to the photoelectric receivers. The light rays emerging from the deviating wedges are thus used both for coarse and for fine adjustment.

I claim:

1. In combination with a photographic camera having a housing, a range finder device comprising:
 optical range finder means mounted in said camera and responsive to first and second light fluxes originating from object areas having an indication of the camera range setting;

including a first light flux sensing element located in the path of said first light flux and a second light flux sensing element located in the path of said second light flux, said two light flux sensing elements connected to indicator means responsive to differential changes between the two light fluxes, thereby discriminating between the condition when the light fluxes originate from unequal object areas and the condition when the light fluxes received are identical in that they originate from a common object area or from separate light flux equivalent object areas; and

means in said housing for simultaneous viewing of said indication of the camera range setting and said indicator means whereby further discrimination is obtained between the condition when the identical light fluxes originate from a common object area and the condition when they originate from separate, light flux equivalent object areas whereby the optical range finder means gives a coarse visual control of the camera range setting and the photoelectric range finder means gives the precise reading of the camera range setting.

2. The device as defined in claim 1, wherein the photoelectric range finder means further includes a power source supplying alternating current to its circuitry which is of the differential-balance-type, two identical photo-resistors in this circuitry serving as the light-flux-sensing elements, and optical means directing the light flux originating from at least a portion of the object area to said resistors, whereby the portion of the object area received by at least one of the resistors shifts in response to changes in the camera range setting.

3. The device as defined in claim 2, wherein the optical range finder means are of the triangulation-type and include two spaced image receiving means for viewing of at least a portion of the object area through each of said means, and mirror means to combine the two images thus received into a coincidence-type comparison image, the mirror means including orientable means for the shifting of at least one of the object area portions viewed in response to changes in the camera range setting; and wherein

the photoelectric range finder means further include optical means in the path of each of the two images received by the optical range finder means, thereby deflecting a fraction of the light flux from the two images to the two photo-resistors for simultaneous optical and photoelectric comparison of the two images received.

4. The device as claimed in claim 3, wherein one of the image-receiving means also serves as a view finder means and includes a view finder/optical range finder ocular, the coincidence-type comparison image being a part of the view finder image; and wherein

the photoelectric range finder means further includes as indicator means a movable needle, and further includes a second ocular located adjacent to the view finder ocular for visual reading of the needle position.

5. The device as defined in claim 2, wherein the optical range finder means include, in combination with a single lens reflex camera, a movable mirror, a horizontal imaging screen for the reception of an intermediate image, a field lens above the screen, a pentaprism thereabove, and an ocular serving both as a view finder ocular and optical range finder ocular; and wherein

the photoelectric range finder means include mirror means located on the back side of the pentaprism ahead of the ocular and laterally outside the image field; the two photo-resistors being located between the field lens and the pentaprism outside the image field and arranged side-by-side in the form of parallel, elongated parts tilted in opposite directions around a common transverse surface line, wherein the last-mentioned mirror means reflect a portion of the intermediate image from the screen onto the photo-resistors, which latter register identical light fluxes when the intermediate image is in focus and different light fluxes when it is out of focus.

6. 7 Approved For Release 2009/04/10 : CIA-RDP81-00120R000100010021-3
range finder means are of the ground-glass-type, the intermediate image created on the imaging screen being visible in the view finder/optical range finder ocular; and wherein

the photoelectric range finder means further includes as indicator means a movable needle, and further includes an ocular located adjacent to the view finder ocular for visual reading of the needle position.

5

10

15

20

25

30

35

40

45

50

55

60

65

70

75

[72] **Inventors** Giovanni Odone
 La Rosiaz, Lausanne;
 Jesus DeAndres; Virgilio Cossetta,
 Yverdon, Switzerland

[21] **Appl. No.** 686,554

[22] **Filed** Nov. 29, 1967

[45] **Patented** Jan. 26, 1971

[73] **Assignee** Paillard S. A.
 Vaud, Switzerland
 a company of Switzerland

[32] **Priority** Dec. 15, 1966

[33] **Switzerland**

[31] **18117/66**

3,333,105 7/1967 Kossakowski 250/210
 3,336,851 8/1967 Warshawsky 88/1HF
 2,897,722 8/1959 Gunter, Jr. et al. 250/204X
 3,385,159 6/1968 Bliss et al. 356/4

FOREIGN PATENTS

1,121,838 1/1962 Germany 95/45
 1,213,229 11/1963 Germany 95/44
 486,484 9/1952 Canada 356/4

OTHER REFERENCES

Horman, M., "The Determination of Atmospheric Transmissivity by Backscatter from a Pulsed Light Separated System," Armed Services Technical Information Agency, Doc. No. 243,930, Oct. 1958.

Primary Examiner—James W. Lawrence

Assistant Examiner—C. M. Leedom

Attorney—McGlew and Toren

[54] **TELEMETER CHIEFLY INTENDED FOR PHOTOGRAPHIC PURPOSES**
 10 Claims, 3 Drawing Figs.

[52] **U.S. Cl.** 250/216,
 250/210, 250/235, 350/101, 350/294, 356/4

[51] **Int. Cl.** H01j 3/14

[50] **Field of Search** 95/44, 45,
 44C; 88/1HF, 1U; 250/234, 235, 210, 217, 2.4;
 350/101, 294; 356/4

[56] **References Cited**

UNITED STATES PATENTS

| | | | |
|-----------|---------|-----------------|---------|
| 2,339,780 | 1/1944 | Huitt | 95/44 |
| 2,490,052 | 12/1949 | Harris | 350/294 |
| 2,968,994 | 1/1961 | Shurcliff | 88/56 |
| 3,185,059 | 5/1965 | Durst | 95/44 |
| 3,218,390 | 11/1965 | Bramley | 350/294 |
| 3,218,909 | 11/1965 | Fain | 250/235 |
| 3,224,319 | 12/1965 | Robert | 88/1U |

ABSTRACT: A compact telemeter measuring comparatively short distances, chiefly for photographic purposes, comprising a projector sending a beam of substantially parallel rays of light onto an object the distance of which is to be ascertained, an optical system receiving said beam after reflection on said object and the axis of which is directed in parallelism with the axis of the projector and means sensitive to the location of the point of convergence of the beam of light after it has passed through the optical system. Said means are advantageously constituted by two photocells lying on the axis of the optical system and the relative illumination of which depends on the location of said point of convergence along said axis. This relative illumination controls an electric circuit shifting the cells into a position of equal illumination defining the distance to be measured.

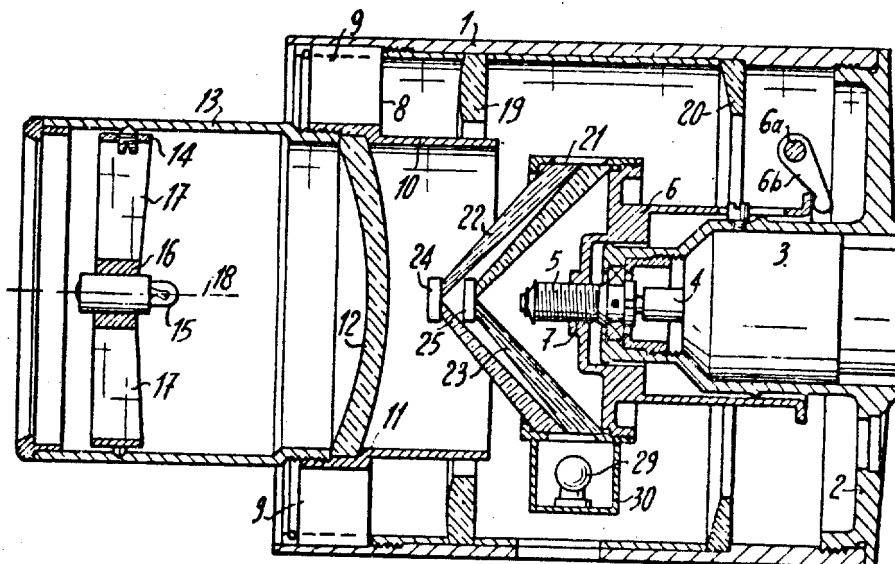

PATENTED JAN 26 1971

3,558,894

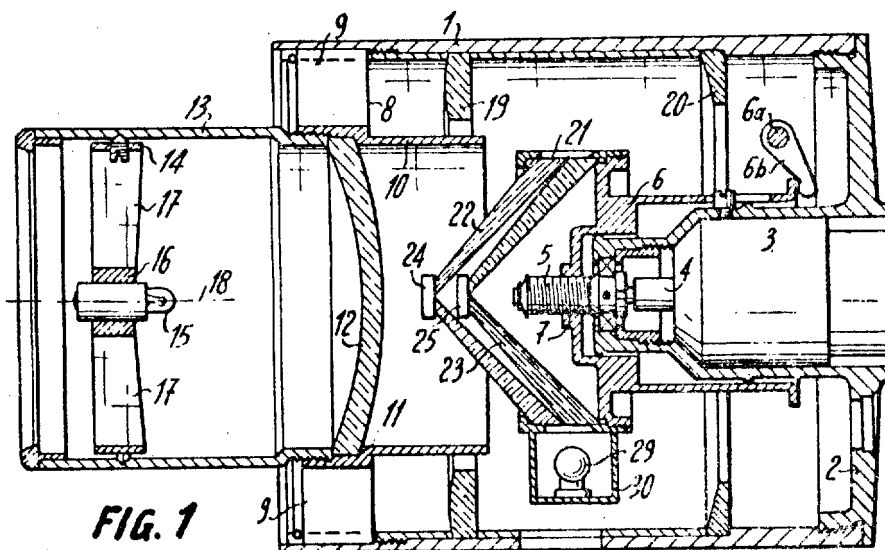

FIG. 1

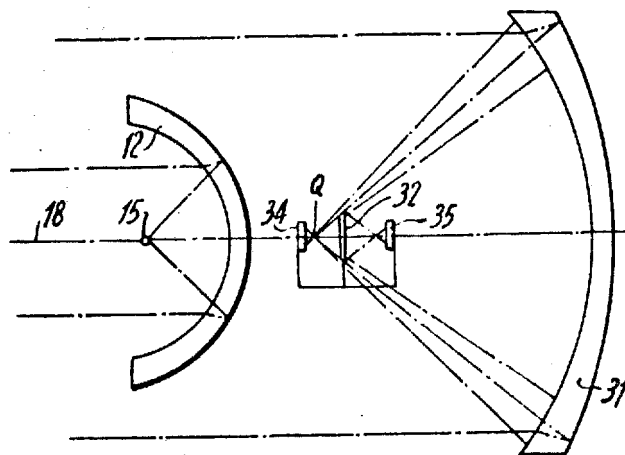

FIG. 3

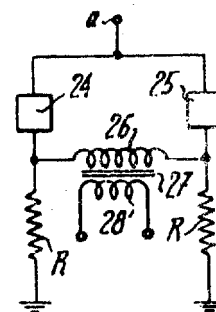

FIG. 2

INVENTORS
GIOVANNI Odone
JESUS DE ANDRES
VIRGILIO COSSETTA

BY *Maryleu and Loren*

TELEMETER CHIEFLY INTENDED FOR PHOTOGRAPHIC PURPOSES

The present invention has for its object a telemeter, chiefly intended for photographic purposes. Such a telemeter serves mainly for measuring comparatively short distances, generally less than about 10 meters.

Arrangements have already been proposed for measuring distances by means of infrared rays for instance. Such prior known arrangements are adapted for measuring comparatively large distances and their execution is based on the same principle as optical telemeters. In practice, the distances are measured by the angle within which a receiver collects infrared rays issuing from a source lying at a location remote from said receiver and reflected by the object of which it is desired to measure the distance.

The arrangements known hitherto allow measuring accurately comparatively long distances, of a magnitude of about several times 10 meters, but they are on the other hand bulky and require a comparatively considerable spacing between the receiver and the transmitter constituted by the source of infrared rays.

The present invention has now for its object a telemeter to be used chiefly for photographic purposes, which telemeter includes a projector supplying a narrow luminous beam and at least one convergent optical receiving system of which the optical axis is directed in substantial parallelism with that of the projector so as to collect the rays of the beam which are reflected by the object of which it is desired to measure the distance, while one or more devices are provided, which are sensitive to the distance at which the rays collected by the receiver converge.

The accompanying drawing illustrates diagrammatically and by way of example two embodiments of the invention. In said drawing:

FIG. 1 is a sectional view of a telemeter according to the first embodiment.

FIG. 2 is a wiring diagram for said embodiment.

FIG. 3 illustrates a second embodiment.

The telemeter illustrated in FIG. 1 is enclosed in a casing 1, the rear end of which is closed by a flange 2 screwed inside the body of the casing 1. Said flange 2 carries an electric motor 3 driving into rotation through its shaft 4 a screw 5. The latter engages a threaded opening 7 formed in a member 6 adapted to slide over the inwardly projecting portion of the flange 2, which encloses the motor 3. Said member 6 carries optical parts to be described in detail hereinafter.

The front end of the casing 1 is adapted to carry a ring 8 provided with an annular series of openings 9 which allow light to enter the casing 1. Said ring 8 includes an inwardly projecting cylindrical section 10 of a reduced diameter forming a shoulder or bearing surface 11 for a concave reflector 12. The latter is held in position by a coaxial tubular member 13 screwed into the ring 8 and enclosing a support 14 for a central sleeve 16 carrying a bulb 15. The rim of the support 14 is connected with the central sleeve 16 by radial arms 17 so that the bulb lies on the optical axis 18 of the reflector 12.

The luminous rays passing out of the bulb 15, of which the filament or the arc forms substantially a pin point, are reflected by the reflector 12 and through the front opening of the tubular member 13 in the shape of a beam the rays of which are parallel with the optical axis 18.

The bulb 15 and reflector 12 forms thus a projector supplying a compact beam directed towards the object of which it is desired to ascertain the distance with reference to the telemeter, which latter is generally associated with a photographic or kinematic camera.

Preferably, the light supplied by the projector 12—15 is modulated at a comparatively low frequency, for instance of a magnitude of a few 10 cycles per second, so as to allow differentiating the luminous rays produced by the projector when reflected, from any parasitic luminous rays. Said modulation of the light may be obtained in a simple manner by successive interruptions of the current feeding the bulb 15, but obviously it is possible to resort also to other means, for instance to an

electromagnetically energized vibratory blade extending in proximity with the bulb 15 across the path of the rays directed towards the reflector 12.

A fraction of the rays reflected by the distant object enters the casing 1 in the shape of an annular beam defined by the gap between said casing 1 and the tubular member 13. Said rays pass in fact through the openings 9 of the ring 8 and thence through an annular optical glass element 19. The latter shows on one side a substantially flat surface and on the other side a toro-shaped surface coaxial with the projector. It acts thus as a convergent cylindrical lens incurved so as to assume an annular shape.

When said element 19 receives the rays passing out of a luminous point located on the axis 18 of the optical system including the projector and the element 19, it produces a real image of said point in the shape of an annulus concentric with the element 19, the axial spacing between said element and said annular image depending of course on the distance between the luminous point and said element 19. When the luminous point is shifted along the optical axis 18, the real image of said point is constituted by a circle moving similarly along said axis 18 while its diameter increases as the point of convergence of the incoming rays moves further away to the rear of the element 19. Thus, the annular images corresponding to the different possible positions of the luminous point along the axis 18 move over a conical surface. On the other hand, the rays collected by the element 19 are received at the rear thereof by an annular mirror 20 in the shape of a frusto-cone the apical angle of which is selected in a manner such that the rays reflected by it converge onto a cylindrical surface 21, coaxial with the axis 18 and located between the planes defined by 19 and 20, the reflected rays impinging on said surface 21 whatever may be the distance separating the element 19 from the luminous point.

The cylindrical surface 21 is formed on two cones 22, 23 of a transparent material, carried by the adjustable member 6. The two cones 22, 23 form guides for the light received on the surface 21 and guide the light towards the corresponding photosensitive cells 24, 25 carried by their apices.

Thus, the point of convergence of the rays reflected by 20 onto the surface is shifted axially as a function of the distance of the object, the distance of which is to be measured. According to the distance of said object and to the position of the member 6 carrying the two cones 22 and 23, the intensity of the light collected by the cell 24 varies with reference to that of the light collected by the cell 25. Said difference in light intensity generates a difference between the electric conditions of the two cells, which latter difference may serve for controlling the motor 3 and causing it to rotate in a direction such that it shifts the member 6 with the cones 22 and 23 until the two cells 24 and 25 are subjected to equal luminous intensities.

To each distance between the object of which it is desired to ascertain the distance and the telemeter, there corresponds consequently a predetermined position for the member 6. Thus, the position of equal illumination for the cells 24 and 25 allows defining the distance of the object by noting the position of the member 6. Said distance may, for instance, be read by means of an index, not illustrated, actuated by a rod 6a carrying an arm 6b urged elastically into contact with the member 6. Said rod 6a may furthermore serve for the mechanical actuation of the ring controlling the adjustment of the ranges on a camera coupled with the telemeter described.

Obviously, the telemeter described can be operative only if at least one of the cells 24, 25 actually receives a fraction of the rays reflected by the object, the distance of which is to be measured. The cylindrical surface 21 should therefore have a length sufficient in a direction parallel with the optical axis 18 for one of the cells 24, 25 to be energized by the rays sent by the object into the telemeter, when the object lies at one limit of the range of measurements allowed by the telemeter, while the instantaneous adjustment of the member 6 corresponds to the opposite limit of said range.

If, for structural reasons, it is not possible to give the cylindrical surface 21 a sufficient length, for instance because it may be of interest to provide a very broad measuring range for the telemeter, the telemeter should be provided with a rough manual preliminary adjusting mechanism adapted to bring said surface 21 into a position where it may receive the light reflected by the distant object.

If the cylindrical surface 21 has a length sufficient for it to receive the rays reflected by the object throughout the range of measurements of the telemeter, it is of advantage to provide the latter with an arrangement for the automatic return to the infinite when neither of the two cells 24, 25 produces a signal corresponding to the reception of the reflected beam. As a matter of fact, if the object of which it is desired to ascertain the distance is too remote, the energy of the reflected luminous beam is too weak for it to make the cells 24, 25 produce a perceptible output signal. It is therefore of interest in such a case for the telemeter to indicate a very large distance which may be considered as equivalent to the infinite.

FIG. 2 illustrates diagrammatically means connecting the two cells 24, 25 when the latter are photoconductive cells. One electrode of each of the two cells 24, 25 is connected with a common terminal *a* showing a difference in voltage with ground. The other electrode of each of said two cells is grounded through the agency of a resistance *R*. The two resistances *R* have the same value. Furthermore, the grounded electrodes of the cells 24, 25 are connected with each other through the primary winding 26 of a transformer 27. Said wiring diagram constitutes a bridge of which two arms are formed by the photoconductive cells 24, 25, the two other arms being formed by the resistances *R*. Since the light defining the distance of the object is modulated by reason of the modulation of the beam produced by the projector, the cells 24, 25 supply a variable electrical magnitude showing a component of the modulation of which corresponds to that of the projector. Consequently, the primary 26 is fed by an alternating current whenever the two cells 24, 25 do not receive the same amount of modulated light and this produces an output voltage across the terminals of the secondary 28 of the transformer 27. Said output voltage serves for starting the motor 3 in the direction required for shifting the member 6 with the two cones 22, 23 until the line separating the latter registers with the annular illumination produced by the rays reflected by the reflecting surface 20. The direction along which the motor 3 is to be driven is detected readily by comparing the phase of the current supplied by the secondary 28 with the modulation of the projector beam.

Obviously, the two cells 24, 25 can receive luminous rays other than those produced by the bulb 15, but since said other rays are not modulated, they cannot produce any induced alternating voltage in the secondary 28 of the transformer 27.

However, an error may occur if a comparatively important difference in illumination due to parasitic rays arises between the two cells. To reduce such an effect and to increase the accuracy of the telemeter, it is of interest to provide a luminous source inside the casing 1, so as to produce an unvarying comparatively important illumination for said cells. Thus, the characteristic properties of both cells are practically similar for the modulated rays they receive.

In FIG. 1, said auxiliary source of light is constituted by a bulb 29 carried inside a small casing 30 opening towards the cylindrical surface 21 formed on the cones 22 and 23. Thus, both cells 24 and 25 receive a continuous luminous component of an intensity which is much larger than that of any external parasitic rays liable to alter the accuracy of the measurements. The action of such parasitic rays becomes consequently quite negligible.

FIG. 3 illustrates a modification according to which the bulb 15 supplies a beam of parallel rays as provided by the reflector 12, the rays returning after reflection by the body being collected by the reflecting surface 31 which causes them to converge onto the optical axis 18. The point of convergence for the rays, when perfectly parallel, is designated by *Q*.

The rays reflected by the reflecting surface 31 may be cut off by a circular rearwardly facing mirror 32 located between the two cells 34 and 35. If the convergence of the reflected rays is larger than that illustrated in the drawing for the focus *Q*, the reflected rays are cut off by the mirror 32 and are sent back onto the cell 35. If, in contradistinction, the convergence of the rays is less, the totality of the latter reaches the cell 34 without being cut off by the mirror 32. It is therefore possible to shift the mirror 32 and to bring it into a position such that the two cells 34 and 35 are equally illuminated, which allows defining the distance of the object as a function of the position occupied by the mirror 32 corresponding to equal illumination of the two cells 34 and 35.

It is well-known in the art that the sources of light are never perfectly pinpoints and consequently it is not possible in practice to obtain, with the projector described, a beam with perfectly parallel rays. Consequently, the reflector 12 forms on the object an image of the luminous source or bulb 15, said image being generally blurred because it is not focused. If it is desired to obtain an excellent accuracy with the arrangement described, it is an easy matter to provide a mechanical coupling between the member 6 and the bulb 15 or the reflector 12. Thus, at the beginning of the measurement, when the luminous image is blurred, the conjugated image of the latter is formed by an annular blurred luminous line on the cylindrical surface 21. However, said blurred line is sufficiently spaced with reference to the line separating the cones 22 and 23 for a sufficient difference in illumination to be obtained between the cells 24 and 25, so that the motor 3 is driven into rotation in the direction urging said separating line towards the annular luminous line.

While said displacement is being produced, the motor 3 also adjusts the distance between the bulb 15 and the reflector 12, which ensures the accurate focusing of the conjugated image of the bulb 15 for a distance equal to the that corresponding to the actual position of the member 6. Thus, as the member 6 moves nearer the position corresponding to the distance to be measured, the focusing of the image of the bulb 15 on the object is improved and when the member 6 reaches this position corresponding to the actual distance, the focusing is excellent. Thus, the rays collected by the element 19 form on the surface 21 a clean luminous line which registers with the line of separation between the cones 22 and 23. The apparatus ensures in this manner a very high accuracy.

It should be noted that the telemeter described may be subjected to various modifications within the scope of the accompanying claims. In particular, the reflecting surfaces or mirrors may be replaced by lenticular systems.

It is not essential for the projector and the optical receiver to be coaxial, since the telemeter may still operate normally in the case where the optical axes of the projector and of the optical receiver are slightly shifted transversely with reference to each other, in principle by a distance less than the diameter of the luminous spot produced on the object of which it is desired to ascertain the distance.

We claim:

1. A telemeter, useful in measuring distances to an object, chiefly for photographic purposes, comprising projector means arranged to transmit a beam of substantially parallel rays of light to the object the distance of which is to be measured, a convergent optical receiving system arranged to receive a reflected beam from the object and the axis of said system being disposed in substantially parallel relationship with the axis of said projector means, means sensitive to the location of the point at which the rays of light of the reflected beam passing out of said optical system converge on the axis of said optical system, and said projector means comprising a reflector positioned forwardly of said optical receiving system in the direction of the object to be measured, said reflector having a concave face directed toward the object, a substantially pinpoint source of light located at the focus of said reflector, said optical receiving system comprising an annular convergent lens forming member coaxial with said reflector

5

and having its outer diameter larger than the diameter of said reflector, two rearwardly flaring cones of transparent material nested one within the other, said cones being coaxial with said lens-forming member and the rearwardly facing surface of said cones forming a cylindrical surface coaxial with said cones, and means for directing the rays of light of the reflected beam passing through said lens-forming member onto said cylindrical surface for passage through said cones to the apices thereof, and said sensitive means comprising a pair of closely spaced photocells adjacent the apices of said cones to be illuminated by the rays of light of the convergent beam to an extent varying with the location of the point of convergence with said optical axis.

2. A telemeter, useful in measuring distances to an object, chiefly for photographic purposes, comprising projector means for transmitting a beam of substantially parallel rays of light to the object the distance of which is to be measured, a convergent optical receiving system having an optical axis in substantially parallel relationship with the axis of said projector means and arranged to receive a reflected beam from the object being measured, said optical system arranged to converge the reflected beam received from the object, photoelectric means arranged for receiving the reflected beam from said optical system, wherein the improvement comprises said photoelectric means comprising at least two sensitive portions spaced with respect to the locus of the possible convergence of the reflected beam, said optical system comprising annular convergent lens-forming means arranged concentrically about the optical axis of said optical system for collecting the rays of the reflected beam and for directing the reflected beam to said photoelectric means, separator means disposed between said annular convergent lens-forming means and said photoelectric means for separating the reflected beam into two portions with each portion being directed to a different one of said sensitive portions of said photoelectric means, a drive member for displacing said photoelectric means within the range of possible locations of convergence of the reflected beam, and means interconnecting said drive member and photoelectric means for actuating said drive member when said sensitive portions of said photoelectric means are receiving unequal intensities of light from the reflected beam for positioning said photoelectric means until it receives equal intensities of light from the reflected beam.

3. A telemeter, as set forth in claim 2, wherein said sensitive portions of photoelectric means comprises a pair of spaced photoelectric cells each exposed to a different one of the two portions of the reflected beam received from said optical receiving system after its division by said separator means.

4. A telemeter as set forth in claim 2 wherein said sensitive portions of said photoelectric means comprising a pair of closely spaced photocells arranged on the axis of said optical system for receiving separate rays of light from the reflected beam to a varying extent, and said means interconnecting said drive member and photoelectric device comprising an electric circuit fed differentially by said photocells according to the location of the point of convergence of the reflected beam on the optical axis and consequently to the distance to be measured, and means for modulating the reflected beam passing through said optical system, and an auxiliary source of light arranged to produce a permanent illumination of said photocells.

5. A range finder for measuring the distance to an object, particularly for use in photography, comprising a projector means for directing a narrow light beam to an object whose distance is to be measured, and a convergent optical receiving system capable of forming an image of the portion of the object lighted by the light beam with the image formed by said convergent optical system being shifted parallel to itself along the optical axis of said optical system in dependence on the distance of the object, wherein the improvement comprises a detector device capable of being displaced along the optical axis, said detector device comprising a separator element for separating the luminous flux forming the image into two

6

separate beams with the proportion of the luminous fluxes forming the two beams being dependent on the position of said separator element with respect to that of the image, said optical system comprising convergent lens-forming means arranged concentrically about the optical axis of said optical system for collecting the luminous flux reflected from the object and for directing the luminous flux to said separator element, photoelectric means designed to measure and compare the intensity of the luminous fluxes of the two beams, and means in operative communication with said photoelectric means for displacing said detector device along the optical axis for bringing said detector device into the position for which the ratio of the two luminous fluxes measured by said photoelectric means assumes a given value.

6. A telemeter, useful in measuring distances to an object, chiefly for photographic purposes, comprising projector means for transmitting a beam of substantially parallel rays of light to the object the distance of which is to be measured, a convergent optical receiving system having an optical axis in substantially parallel relationship with the axis of said projector means and arranged to receive a reflected beam from the object being measured, said optical system arranged to converge the reflected beam received from the object, photoelectric means arranged for receiving the reflected beam from said optical system, wherein the improvement comprises said photoelectric means comprising at least two sensitive portions spaced with respect to the locus of the possible convergence of the reflected beam, said optical system comprising a concave mirror reflecting surface arranged coaxially with the optical axis of said optical system for collecting the rays of the reflected beam and for directing the reflected beam to said photoelectric means, separator means disposed between said reflecting surface and said photoelectric means for separating the reflected beam into two portions with each portion being directed to a different one of said sensitive portions of said photoelectric means, a drive member for displacing said photoelectric means within the range of possible locations of convergence of the reflected beam, and means interconnecting said drive member and photoelectric means for actuating said drive member when said sensitive portions of said photoelectric means are receiving unequal intensities of light from the reflected beam for positioning said photoelectric means until it receives equal intensities of light from the reflected beam.

7. A range finder for measuring the distance to an object, particularly for use in photography, comprising a projector means for directing a narrow light beam to an object whose distance is to be measured, a convergent optical receiving system capable of forming an image of the portion of the object lighted by the light beam, and detector means displaceable along the optical axis of said convergent optical receiving system, wherein the improvement comprises said convergent optical receiving system including optical means arranged to form a substantially plane linear image of the portion of the object lighted by the light beam, said detector means comprises a separator element movable with said detector means along the optical axis of said convergent optical receiving system to keep substantial coincidence with the surface generated by the linear image when the distance of the object to be measured is varied within the useful range of the range finder, said separator element separating the luminous flux forming the image into two separate beams with the proportion of the luminous fluxes forming the two beams being dependent on the position of said separator element with respect to that of the image and said detector means comprises photoelectric means designed to measure and compare the intensity of the luminous fluxes of the two beams.

8. A range finder, according to claim 7, wherein the substantially plane linear image formed by said optical means in said convergent optical receiving system provides a generated surface which is substantially a cylindrical surface whose generating lines are parallel to the optical axis of said convergent optical receiving system when the distance of the object

3,558,894

7

to be measured is varied with the useful range of the range finder.

9. A range finder according to claim 8 wherein said optical means in said convergent optical receiving system comprise an annular convergent lens-forming member and a frustoconical annular mirror member, with both said members being coaxial.

10. In a range finder for measuring the distance to an object, particularly for use in photography, comprising a projector means for directing a narrow light beam to an object whose distance is to be measured, the improvement comprising, in combination, an optical receiving system forming a substan-

8

tially plane linear image of the portion of the object lighted by the light beam, this image being in the form of symmetrical arc portions of a circle centered on the optical axis of said optical receiving system, a detector device comprising separator means displaceable along said optical axis to a position where said separator means coincide with symmetrical parts of the linear image, said separator means separating the luminous fluxes forming each of the symmetrical parts of the linear image into two separate beams and said detector system comprising photoelectric means designed to measure and compare the intensity of the luminous fluxes of the two separate beams.

15

20

25

30

35

40

45

50

55

60

65

70

June 13, 1972

W. J. RATTMAN ETAL

3,669,540

OPTICAL DEPTH FINDER AND ELEMENTS THEREFOR

Filed Aug. 31, 1970

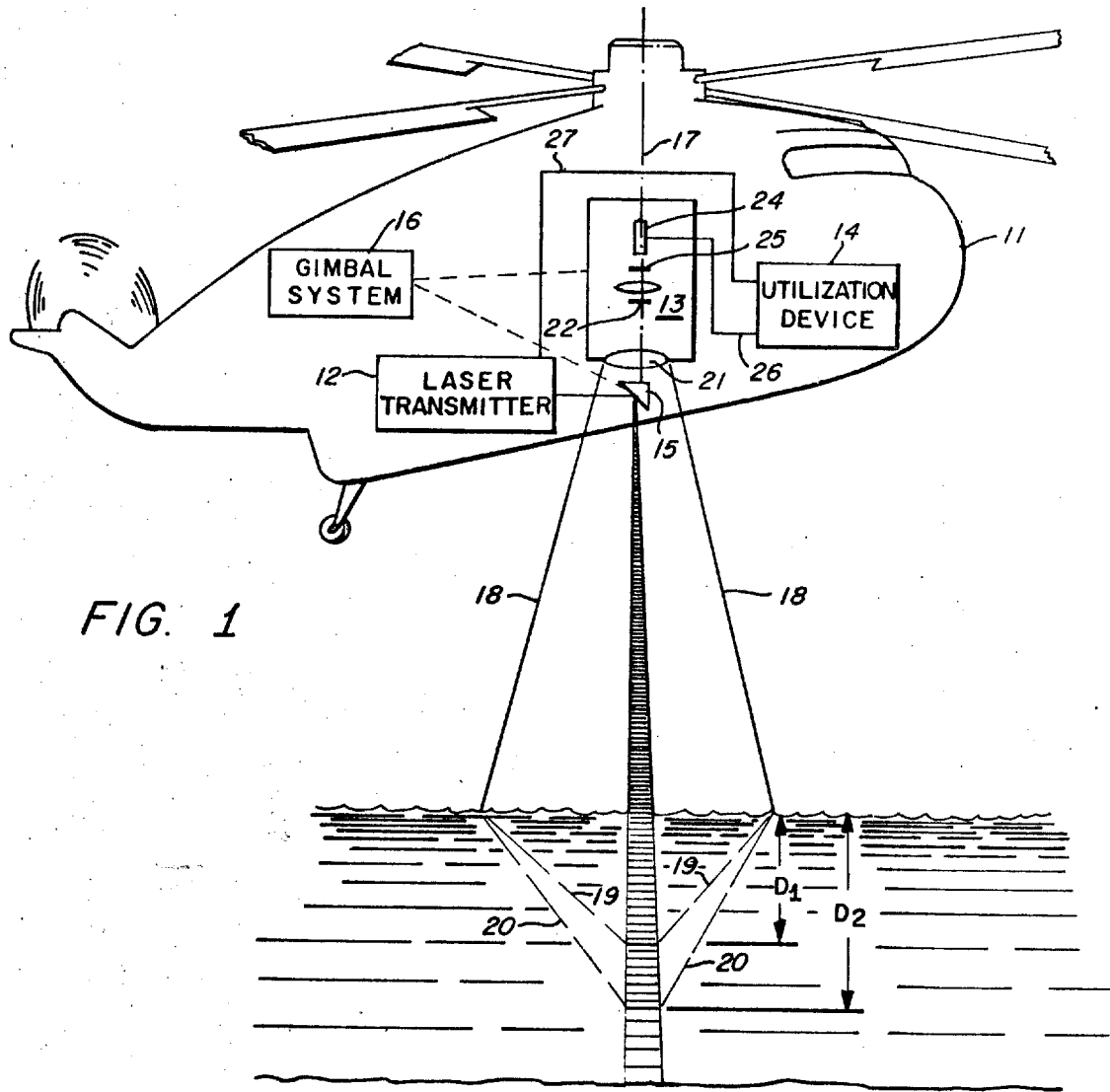

FIG. 1

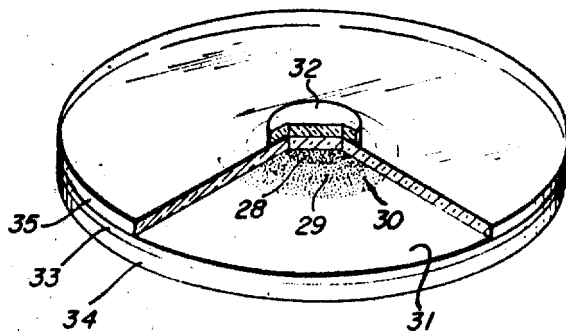

FIG. 2

INVENTORS
WILLIAM J. RATTMAN
FRANK R. WASSON, JR.
GORDON C. MacKENZIE

1

2

3,669,540
OPTICAL DEPTH FINDER AND
ELEMENTS THEREFOR

William J. Rattman, Needham, Frank R. Wasson, Jr.,
Chelmsford, and Gordon C. MacKenzie, North
Billerica, Mass., assignors to Raytheon Company, Lex-
ington, Mass.

Filed Aug. 31, 1970, Ser. No. 68,206
Int. Cl. G01c 3/08; G02b 27/28

U.S. Cl. 356-4

7 Claims

ABSTRACT OF THE DISCLOSURE

An improved optical depth finder, and elements therefor, for depth sounding and detection of submerged targets from an airborne vehicle. The disclosed system uses a coherent beam of polarized light from a laser directed downwardly toward the surface of a body of water and processes the polarized surface specular reflected energy, energy reflected by submerged targets within the beam, and energy reflected by the bottom of the body of water to derive the desired information. Means are provided selectively to attenuate the reflected energy in accordance with the particular source thereof so as to permit the dynamic range of the processor of the reflected energy to be reduced and the system to be used when the height of the airborne vehicle changes or condition of the water varies.

The invention herein described was made in the course of or under a contract or subcontract thereunder, with the Department of Defense.

BACKGROUND OF THE INVENTION

This invention relates generally to laser depth measuring systems and particularly to optical filters used in the receivers of such systems.

Laser depth measuring systems using pulses of light are known for the rapid accurate sounding of the depth of a body of water, as the ocean, and for the detection of submerged objects. The depth of the ocean or of the submerged object is generally determined by measurement of the interval between the detection of the energy reflected from the ocean surface and the energy reflected from the ocean floor or from the submerged object. When such a system is displaced from the ocean surface, as when it is used on board a helicopter, the altitude of such helicopter is determined by measurement of the interval between the time of transmission of each laser pulse and the time of detection of the resulting energy reflected from the ocean surface.

The power of the reflected return varies greatly in magnitude as the transmitted pulse is first reflected by the ocean surface, then ocean medium and any submerged target therein, and finally the ocean floor. While the absolute magnitude of such power varies with aircraft altitude, ocean surface roughness and ocean depth, under any condition an extremely large relative difference in amplitude of reflected energy is encountered. For example, the predominantly specular reflections from the ocean surface produce signals which may 70 db greater than signals resulting from reflections from points immediately below the ocean surface and may be 90 db greater than signals caused by reflections from the ocean floor. These characteristics place stringent requirements on the dynamic range of the receiver. In particular, if a photomultiplier is used as the photodetector of the receiver, reflections from the ocean surface may saturate the photomultiplier, thereby preventing soundings from being made or submerged targets from being detected. This equivalent

saturation phenomenon occurs if a photodiode-amplifier combination is used as the receiver photodetector.

One approach to the solution of this problem has been "range gating," that is, a plurality of photodetectors are employed, each one of such photodetectors having a different sensitivity, in combination with gating logic wherein the photodetector of proper sensitivity is activated at the proper time to thereby detect the various returns. Such a system is complicated and expensive.

A second approach to the solution of this problem is to place an optical filter in the focal plane of the receiver, the center portion of the filter being of sufficient optical density to greatly attenuate the relatively large power of the reflected returns from the ocean surface. However, because of the density required of such center portion, the measurement of shallow ocean depths may be prevented.

SUMMARY OF THE INVENTION

It is, therefore, an object of the invention to provide an improved laser depth sounding system.

It is another object of the invention to process reflected energy of a laser depth sounding system so that specular reflections from the surface of the measured medium are selectively attenuated.

It is another object of the invention to provide a filter to attenuate more greatly backscatter reflections from points nearer the surface of the measured medium than backscatter reflections from points near the bottom of the measured medium.

These and other objects of the invention are generally accomplished by combining means for directing a beam of coherent polarized light from a laser and means, including a polarized filter in cross-polarized relationship to the substantially polarized energy resulting from specular reflections from the ocean surface, for selectively attenuating such surface specular reflections prior to their detection by the receiver photodetector. In addition, an optical wedge is disposed in the path of the reflected energy, the optical density and related energy attenuation factor of such wedge decreasing from its center portion to its peripheral section so as selectively to attenuate reflections from points nearer the ocean surface to a greater degree than reflections from points nearer the ocean bottom.

BRIEF DESCRIPTION OF THE DRAWINGS

For a better understanding of the present invention reference should now be made to the following description taken in connection with the accompanying drawings in which:

FIG. 1 is a presentation of an airborne laser ocean depth sounding system greatly simplified in order to show the principles of the invention; and

FIG. 2 is a sketch of a polarized optical wedge, partially broken away and somewhat distorted, to show the construction thereof.

DESCRIPTION OF THE PREFERRED EMBODIMENT

FIG. 1 shows a laser depth sounding system carried within an airborne vehicle 11, here shown as a helicopter, for use in oceanographic survey. The depth sounding system comprises a laser transmitter 12, a laser receiver 13 and a utilization device 14. The laser transmitter 12, here a Q-switched frequency doubled yttrium aluminum garnet device of sufficient power considering the depth of the ocean, produces a linearly polarized coherent laser beam (not numbered) of transmission wavelength 0.53 μ , such wavelength being near the peak of the ocean transmission "window." Such laser beam is reflected by transmitter mirror 15 so that it is transmitted along a path substantially orthogonal to the ocean sur-

3,669,540

3

face. Such orthogonal attitude is maintained by mounting the laser transmitter 12, the transmitter mirror 15 and the laser receiver 13 on a common platform (not shown), such platform being gimballed with respect to airborne vehicle 11 by gimbal system 16. The transmitter mirror 15 is disposed in proper orientation to the receiver boresight axis 17 so that the laser beam (after reflection from transmitter mirror 15) and the receiver boresight axis 17 are essentially coaxial. The transmitter mirror 15 is small relative to the receiver collecting aperture.

The energy in the transmitted beam is partially reflected first by the ocean surface, then the ocean medium (including any submerged targets, not shown) and finally by the ocean floor. The maximum field of view of the receiver 13 is herein represented by lines 18. In order for detection by receiver 13 of subsurface backscatter reflections occurring at depth D_1 and greater depth D_2 , such subsurface reflections must propagate towards the receiver and be refracted by the wave facets at the ocean surface so as to be within the field of view of the receiver. While such backscatter reflections propagate in many directions, the reflection at depths D_1 and D_2 which are within the maximum field of view of the receiver are represented by lines 19 and 20 respectively. It is noted that the amount of refraction at the ocean surface required for backscatter reflections at depth D_1 to be within the maximum field of view of the receiver is larger than that amount of ocean surface refraction required at greater depth D_2 . Since large ocean surface refraction will occur with large wave facet slopes, and since the probability for smaller wave facet slopes is greater, the greatest amount of reflected energy from shallow targets is collected at the receiver near the receiver boresight axis 17, while a correspondingly greater percentage of reflected energy from greater depths will be collected further off the receiver boresight axis 17. That is, the field of view in the focal plane of the receiver is smaller for subsurface backscatter returns occurring near the ocean surface as compared with reflections near the ocean bottom.

It is also noted that the polarized transmitted pulse reflected by the ocean surface remains also essentially polarized. In other words, the specular surface reflections are substantially linearly polarized energy. The backscatter reflections occurring immediately below the surface of the ocean are essentially non-polarized.

The various reflected returns, as described in detail above, are collected by the receiver collecting optics 21, herein represented by a lens, whereby such reflected returns are focused at the receiver focal plane. An optical filter 22, such filter being described in more detail hereinafter, is disposed in such focal plane as indicated. The filtering surface of the optical filter 22 is disposed essentially orthogonal to the receiver boresight axis 17, such boresight axis passing through the center portion of the filtering surface. The function of optical filter 22 is to compress the dynamic range of the various reflected returns. The center portion of the optical filter is used to greatly attenuate specular reflections and subsurface backscatter reflections from immediately below the ocean surface since such reflections predominate the center portion of the filter. Subsurface backscatter reflections from nearer the ocean floor are less greatly attenuated by the optical filter 22 than those reflections from near the ocean surface.

Field lens 13 converges the reflected returns filtered by optical filter 22 on the photomultiplier 24. A narrow band filter 25, of conventional design, passes only electromagnetic energy in a narrow spectrum centered at the laser transmitter wavelength, herein 0.53μ . The electrical signal developed by photomultiplier 24 is transmitted to utilization device 14 by transmission line 26. Utilization device

4

art. By measuring the time interval between the initial signal it receives from the photomultiplier 24, representing ocean surface reflections, and the termination of the signal from the photomultiplier, the ocean depth can be determined since the speed of the laser energy in the ocean medium is about 2.72 ns./ft. for a 0.53μ operating wavelength. Utilization device 14 also receives a signal from laser transmitter 12, such signal occurring at the initiation of the transmitted pulse and such signal being transmitted to utilization device 14 by transmission line 27. The interval between the signal from the laser transmitter 12 to the utilization device 14 and the beginning of the reflected signal is used to determine the altitude of airborne vehicle 11.

FIG. 2 shows optical filter 22. Optical filter 22 is a disc-shaped element comprised of a photographic film 33 sandwiched between glass plates 34 and 35. Cemented to the outer portion of glass plate 35 is a disc 32 of linearly polarized material. The photographic film 33 has formed thereon a plurality of concentric rings 28, 29, 30 and 31, each such ring being less dense so that the film has a greater optical density at its center.

In reference to FIG. 1, the linearly polarized disc 32 is oriented in cross-polarized relationship to the linearly polarized energy resulting from specular reflections at the surface of the ocean.

It will be obvious to one of ordinary skill in the art that the graded optical density of the photographic film need not be made up of a plurality of concentric rings but can be a continuous graded density. It is also noted that a polarized material could be formed with a more optically dense center portion than the peripheral portion to thereby form optical filter 22 in one unit. Also, the polarizer could be separate from the graded density filter. In any practical deployment a series of polarized optical filters, as herein described, would be on board the aircraft, each one suitable for a particular set of possible wind, altitude and ocean conditions. It is therefore understood that the invention is not limited to the specific embodiment as shown, but only by the spirit and scope of the appended claims.

What is claimed is:

1. A unidirectionally polarized optical wedge.
2. For use in a laser depth measuring system wherein substantially polarized electromagnetic specular reflections from the surface of a body of water are collected within a receiver, the combination comprising:
 - (a) a disc fabricated from a polarized material, such disc being disposed in the receiver to attenuate the polarized electromagnetic specular reflections; and
 - (b) a photodetector responsive to such attenuated reflections.
3. For use in a laser depth measuring system wherein electromagnetic reflections from a body of water are collected within the field of view of a receiver, such collected electromagnetic reflections being comprised of substantially polarized electromagnetic energy resulting from specular reflections at the surface of the body of water, such substantially polarized energy being concentrated at the center of the field of view of the receiver, and substantially nonpolarized electromagnetic energy resulting from backscatter reflections beneath the surface of the body of water, the intensity of such substantially nonpolarized energy decreasing from the center of the field of view of the receiver to the periphery thereof, the combination comprising:
 - (a) an optical wedge, such optical wedge having a greater optical density at the center portion than at the peripheral portion, such center portion being disposed at the center of the field of view of the receiver, for selectively attenuating the intensity of the nonpolarized energy;
 - (b) a disc, fabricated from a polarized material, such disc being disposed in the receiver to attenuate the intensity of the polarized energy.

3,669,540

- 5 (c) a photodetector responsive to the selectively filtered nonpolarized electromagnetic energy and the attenuated electromagnetic energy.
4. For use in a laser depth measuring system wherein electromagnetic reflections resulting from illumination of a body of water by a polarized beam from a laser are collected within a field of view, such collected electromagnetic reflections being comprised of substantially polarized electromagnetic energy specularly reflected from the surface of the body of water, such substantially polarized energy being concentrated at the center of the field of view, and substantially unpolarized electromagnetic energy backscattered from points beneath the surface of the body of water, such unpolarized energy being concentrated in the peripheral portion of the field of view, the combination comprising:
- 15 (a) a disc, fabricated from a polarized material, such disc being disposed in the field of view selectively to attenuate the intensity of polarized energy and to pass, substantially unattenuated, the unpolarized electromagnetic energy; and,
- 20 (b) a photodetector responsive to the portion of the electromagnetic reflections passed through the disc.
5. A unidirectionally polarized optical wedge, such wedge having an optical density decreasing from its center portion to its peripheral portion and a linear polarization.
- 25

6. A polarized optical wedge, such wedge having a unidirectionally linear polarization, and having an optical density which decreases from its center portion to its peripheral portion.
- 5 7. A unidirectionally polarized optical wedge, such wedge having a linear polarization and formed thereon a series of concentric rings, the optical density of each one of the series of rings decreasing from the centrally disposed ring to the peripherally disposed ring.

References Cited

UNITED STATES PATENTS

| | | | | |
|-----------|---------|-----------|-------|---------|
| 3,437,401 | 4/1969 | Siksai | ----- | 350-153 |
| 3,446,555 | 5/1969 | Kahn | ----- | 356-5 |
| 3,409,368 | 11/1968 | Fernandez | ----- | 356-5 |
| 3,465,347 | 9/1969 | Hudson | ----- | 350-314 |

OTHER REFERENCES

- Sears, optics, 1949, 3rd edition, pp. 39-43.
- BENJAMIN A. BORCHELT, Primary Examiner
- S. BUCZINSKI, Assistant Examiner

U.S. Cl. X.R.

350-153, 314; 356-3, 5, 119