

Chapter IX

★

PEOPLE AND GOVERNMENT

OF

BULGARIA

(JANIS No. 38)

★

OCTOBER · 1943

DOCUMENT NO. 011
NO CHANGE IN CLASS.
 DECLASSIFIED
CLASS. CHANGED TO: TS S C
NEXT REVIEW DATE: _____
AUTH: HR 702
DATE: 8 July 86 REVIEWER: 018995

Table of Contents

	PAGES
90. GENERAL DESCRIPTION	IX - 1 to IX - 3
A. History	IX - 1
B. Contemporary social aspects	IX - 2
C. Government	IX - 2
91. POPULATION—PHYSICAL CHARACTERISTICS	IX - 3
A. Distribution	IX - 3
B. Ethnic groups	IX - 3
92. POPULATION—CULTURAL CHARACTERISTICS	IX - 3 to IX - 4
A. Language	IX - 3
B. Religion	IX - 4
C. Temperament and attitudes	IX - 4
93. HEALTH AND SANITATION	IX - 5 to IX - 6
A. Public health	IX - 5
B. Diseases	IX - 5
C. Precautionary recommendations	IX - 5
94. SOCIAL STRUCTURE AND SOCIAL CONDITIONS	IX - 6 to IX - 8
A. Social groups	IX - 6
B. Stability	IX - 7
C. Education	IX - 7
D. Labor	IX - 7
95. GOVERNMENTAL ORGANIZATION	IX - 8
A. Locus of authority	IX - 8
B. Local government	IX - 8
C. Efficiency	IX - 8
96. SECURITY AND PUBLIC ORDER	IX - 8 to IX - 9
A. Police	IX - 8
B. Other officials with policing power	IX - 9
C. Penal institutions	IX - 9
D. Pertinent legal peculiarities	IX - 9
97. POLITICAL FACTORS	IX - 9 to IX - 11
A. Political organizations	IX - 9
B. Current trends in foreign policy	IX - 10

Confidential

Chapter IX

Page IX - 1

PEOPLE AND GOVERNMENT (INCLUDING HEALTH AND SANITATION)

90. General Description

A. History.

In 680 A.D. a small tribe of Central Asian Bulgars, of Turanian origin, established the First Bulgarian Empire. They gradually extended their power over most of the Slavs of the Balkans. This Empire lasted to 1018, and witnessed the conversion of the people to Greek Orthodox Christianity, the introduction of the Cyrillic alphabet, and the gradual but complete fusion of Slavs and Bulgars.

After two centuries of Byzantine domination, a Second Bulgarian Empire (1186-1393) extended its power north of the Danube, and from the Black Sea to the Adriatic, including the Aegean littoral. This Empire furnished a basis for present-day Bulgarian claims to Balkan hegemony. The Ottoman Turks conquered the Second Empire in 1396. During the five centuries of Turkish subjection, Bulgarian survival was ensured by the Church and by certain privileges granted by the Sultan for services rendered.

A national revival began in the eighteenth century. It culminated in revolutions which the Turks put down brutally. After the Russian victories over the Turks in the Russo-Turkish war of 1877-78, the treaty of San Stefano (1878) created a Bulgaria so large that Disraeli, fearing Russian influence, cut the country into three parts at the Congress of Berlin (1878): Bulgaria, East Rumelia (reunited with Bulgaria in 1885), and Macedonia. San Stefano remained a blueprint for Bulgarian ambitions. Britain won Bulgaria's enmity and Russia retained her gratitude, in spite of subsequent changes of policy and ideology.

The new Bulgaria's first prince, Alexander of Battenberg, having incurred the enmity of Russia, was forced to abdicate. His successor, Ferdinand of Saxe-Coburg-Gotha (1887-1918), gradually obtained control of both domestic and foreign policy. He relied increasingly on Austro-German support.

In 1912 the Balkan League was formed. Victorious over the Turks in the First Balkan War (1912-13), the Balkan allies disagreed over the settlement, and the Second Balkan war began with an attack by Bulgaria (June, 1913) on Greece and Serbia. By the Treaty of Bucureste (Bucharest) (1913) Bulgaria lost southern Dobrogea* (Dobrudja) in addition to part of Thrace and most of Macedonia.

Bulgaria's role in the First World War was to a large extent pre-determined. King Ferdinand was pro-German. Many Bulgarians then, as now, believed that only with Germany's help could their boundaries be rectified. German exploitation, war-weariness and Wilson's Fourteen Points made Bulgaria

*See Appendix I for all spellings of features. The following spellings of features as used in this Chapter differ slightly from those on G.S., G.S. maps, Series 4072 and 4088: Bebrezh, Bozhurishte, Canara (Kana-Gol), Carasuum, Cherni Iskr, Chiporovtsi, Devna, Dobrich (Bazargio), Dobrinishta, Dubovo, Ellidere, Emine (town), Chiaur Suiuciu (Chiaur Suiuciu), Gorna Dzhumaya, Gorna Orekhovitsa (Gln.-Orekhovitsa), Gulubovo (Gara-Glebovo), Kazanlk, Kharmarli, Koprivshitsa, Kuri Burnu, Ladhene (Lzhene), Musala, Panagyurishte, Paphia (Mt.), Peinirdzhik, Perushitsa, Peshtera, Piraeivs, Pirdop (Pirdol), Polikraishte, Rakovets, Resen (Pesen), Sofiya, Sredets, Strizharov, Surnena Gora (Srneha Gora), Svishtov, Syuyutliika, and Trgovishte.

the first Central Power to surrender, caused the abdication of Ferdinand in favor of his son Boris, and inaugurated the revolutionary peasant dictatorship of Stambuliski. The treaty of Neuilly (1919) deprived Bulgaria of her Aegean littoral (Thrace) and of several segments on her western frontier. The total losses in 1913 and 1919 were 18,974 sq. km. and 665,656 population. These losses cancelled a large part of the Bulgarian gains in the First Balkan War; the net gain still remaining was a territory of 6,800 sq. km. and a population of only 4,810.

After the war one of the main internal problems was the settling of more than 250,000 refugees and exchanged population. Domestic politics were marked by a bloody revolution in 1923, in which the bourgeois Nationalists, in alliance with the Army and the Macedonians, put an end to the Agrarian regime. After two years of reactionary government under Alex. Tsankov the Democratic Entente came into power (1925-31). From 1931 to 1934 the successors to the bourgeois of this Entente were forced to share power with the moderate Agrarians. Throughout this period rival Macedonian groups dominated and kept Bulgaria politically and economically isolated. After 1923, relations with Yugoslavia were constantly strained by Macedonian terrorism, frontier incidents and Serbian reprisals. The establishment of the dictatorship in Yugoslavia (1929) increased the tension. A similar situation with Rumania arose over border incidents and the sequestration of Bulgarian property in Dobrogea. Bulgaria's only official friend was Turkey, with whom a protocol of friendship was signed in 1925. Because of France's sponsorship of the Little Entente her relations with Bulgaria were less than cordial. Neither France nor England made a really serious attempt to buy Bulgaria's friendship with trade. On the other hand, Italy's influence as a champion of revisionism was enhanced by her economic interest in Bulgaria, and cemented by the marriage of Boris to Giovanna, daughter of Victor Emmanuel (1930). But Italy was overshadowed in every way by the rise of Nazi Germany.

In internal Bulgarian politics 1934 was marked by the destruction of a relatively corrupt and inefficient multi-party system and the establishment under King and Army of an authoritarian regime, or dictatorship, which sacrificed most democratic principles. Local administration was placed under strict central control. The surplus educated urban population was sent to the villages to help raise the general standards and to heal the suspicion between city and country which in former times had come close to civil war. Thereafter the most hopeful sign was a gradual return from complete autocracy in 1934-35 to a measure of national and local self-government after 1937. Men and, for the first time in the Balkans, women were allowed to vote in local and national elections. Though the ban on political parties continued, their former leaders remained active in political life and gave it balance.

Internationally, 1934 marked the end of Bulgarian isolation, achieved primarily through the outlawing of the terrorist Macedonian organization which for 15 years had dis-

credited the country. Bulgaria's position was: "We want to be friendly with our neighbors and will work toward Balkan economic and political solidarity, but we will not renounce for all time our claim to peaceable territorial revision." Despite this stand and despite the Balkan Pact, aimed directly at keeping Bulgaria from expanding, relations with all neighbors (especially Yugoslavia) improved. A treaty of "Eternal Friendship" with Yugoslavia in 1937 and a treaty of 1938 permitting Bulgaria to re-arm were the outstanding diplomatic achievements. Good relations with Russia revived Pan-Slavic feeling. Before the outbreak of the present war Bulgaria had achieved a large measure of internal and external political stability, and a period of Balkan cooperation and relative prosperity seemed to be assured. However, the fate of Czechoslovakia and Finland, absolute Bulgarian economic dependence on Germany, the desire of the people not to fight another war or have their country become a battleground, and the British guarantee of Rumania's frontiers, all conspired to bring Bulgaria into the Axis fold. Rewards of Greek and Yugoslav territory followed; nevertheless Bulgarian enthusiasm cooled after Germany's attack on the Soviet Union.

B. Contemporary social aspects.

Bulgaria is relatively homogeneous in language, culture, religion, and standards of living. The only significant ethnic exception is the 600,000 Turks and these do not constitute a serious problem. Much more serious, until recent territorial changes, were the problems arising out of the existence of Bulgarian minorities in neighboring countries.

About 80 per cent of Bulgaria's 7 million inhabitants (including those of southern Dobrogea, but excluding the population of the new Greek and Yugoslav territories) are agricultural. Towns are few and small, more like villages than modern cities. Sofiya is the largest city, with a population of about 500,000. The rural population of Bulgaria is relatively dense: the density per arable acre is more than three times that in France. Individual farms are the smallest in Europe; opportunities for occupations other than farming hardly exist. Yields are low under the prevalent primitive methods of cultivation.

There is little industrialization. The people are not mechanically minded but are clever with their hands. Workers are inured to hardship, long hours and low pay. The social legislation of the country is sufficiently progressive and broad in scope but economic conditions and lack of enforcement render it inoperative.

Malaria in Bulgaria has been greatly reduced through the work of the Rockefeller Foundation. Nevertheless, infant mortality is extremely high, tuberculosis is widespread and medical facilities inadequate. Even in the towns a bath is still cause for congratulation. Toilet facilities are often poor or lacking.

In comparison with neighbors, the Bulgarians pride themselves on their literacy. In fact, a cult of education may be noted to be so strong there that it has given rise to an intellectual proletariat. On the other hand, the Church retains its hold largely because of the conservatism of the masses and the historic role of the Church as a national institution.

The peasant is used to obeying the orders of the village elders and the decrees of the authorities. Crimes are few, although political gangsterism and poverty have lessened respect for law and order. There are certain traditions of local self-government, but strong-arm rule, excessive partisanship

and the spoils system have hardly promoted the development of sound democracy. However, American education and philanthropy have contributed greatly towards a better understanding of democracy in Bulgaria.

The Bulgarian is an avid reader of newspapers. The newspapers are the main source of news as radios are still a luxury. The press was relatively free before 1934 and often contributed to political disagreements. But since 1934 it has been controlled and now obediently reflects the orders of the local propaganda machine representative.

C. Government

Theoretically, Bulgaria is still a constitutional monarchy in which the power is shared by King, Cabinet and Parliament. Practically, Bulgaria is ruled by a dictatorship consisting of King and Cabinet to which the assembly usually gives approval.

The country is governed by a highly centralized bureaucracy consisting of parallel hierarchies of civilian and police officials, appointed by and responsible to the respective Cabinet members. Heads of unions and other national organizations are also government appointed.

The present Cabinet, formed on February 16, 1940 and reconstructed in April, 1942, is composed largely of politically colorless individuals. The single outstanding personality is Mr. Gabrovski, energetic and ruthless Minister of the Interior and ardent pro-German. The popular strength of the Cabinet is found in its appeal for the unification within Bulgaria proper of all the so-called Bulgarian areas. Its policy is to make these lands an integral part of Bulgaria and to make Bulgaria the dominant power of the Balkans. Its sanction by the Sovereign results from all its members being his obedient servants.

The National Assembly, elected in 1940, is called occasionally to approve decrees and laws submitted by the Cabinet. Some opposition to government policies is voiced at the sessions but usually the Assembly does as instructed.

As a German satellite, Bulgaria is subservient to Axis demands, but it is quite jealous of its independence in local administration.

German control in Bulgaria is relatively well concealed. It is exercised primarily through pressure on the government. Most routine orders are transmitted through a liaison office known as the "German Government Commission," headed by Dr. Drager, while German Minister Beckerle handles matters of high policy. Prior to King Boris's death difficult problems were settled at command visits of King Boris to Hitler. However, German control has always been tempered by determined resistance by the King, Cabinet, Army, and people to certain demands.

Control of the country is accomplished by small German Army units in the country and larger ones in neighboring countries, the Gestapo and radio and press propaganda. The most powerful economic control is exercised through the virtual monopoly on exports. Though Germany has paid for only a fraction of the food, tobacco, coal, and ore shipments she has received, Bulgaria can find no other source for manufactured goods. Bulgarian credits in Germany now amount to eighteen billion leva (180 million dollars).

Although Bulgarian industries are not very important to Germany, German capital owns several of the largest enterprises and participates in many of the others. Advisers and experts, such as those at the Pernik coal mines, exercise other



forms of control, as do commercial firms like the Credit Bank and the Trachtleitstelle Suedost, which can stop railway traffic at its discretion. Labor recruiting for jobs in Germany constitutes a form of negative economic control.

Social life is affected by propaganda, the Gestapo and travel restrictions. Also, the German-supported youth organization *Bramnik* acts as an espionage agency among all classes. And the anti-Semitic measures carried out by the government on German insistence constitute an additional important instance of social control.

91. Population—Physical Characteristics

A. Distribution.

(1) *Summary.* Bulgaria at present has an estimated population of 6,450,000. The population of "Greater Bulgaria" is estimated at 8,642,000.

Population shifts in the past 25 years are characterized chiefly by an increase in the population of the larger cities and a decrease in the birthrate. There has also been a gradual shift of population from west to east and from the highlands to the plains. The last complete census was taken in 1934.

(2) *Birthrate.* Bulgaria's birthrate was once among the highest in Europe but has declined approximately 50 per cent since 1924. Per 1,000 people, the 1938 birthrate was 22.9, death rate 13.7, natural increase 9.2, and infant mortality 144.

(3) *Composition.* In 1934 about 43 per cent of the population was less than 23 years old, about 50 per cent between 20 and 59 years and the remainder over 59 years of age. Approximately 80 per cent of the people lived in villages and about two per cent in cities. In the same year there were about 1,285,000 families, averaging four to six members each.

The average population density in 1934 was 153 persons per square mile. The rural average was 290 per square mile of cultivated land, highest urban density about 45,000 in greater Sofiya, highest rural average 1,250 in the Ardino District, and lowest rural average about 33 in the Malko Trnovo District. Other densities are given in Table IX-1.

TABLE IX - 1
BULGARIA, 1934 POPULATION DENSITIES BY ADMINISTRATIVE REGIONS

ADMINISTRATIVE REGION	AREA Sq. Mi.	NO. OF PEOPLE	NO. OF PEOPLE PER Sq. Mi.
Burgaz.....	5,259	551,947	176
Vratsa.....	4,302	739,366	171
Plovdiv.....	6,116	801,755	114
Pleven.....	5,938	996,686	168
Sofiya.....	6,533	1,152,053	176
Stara-Zagora.....	6,005	812,633	135
Shumen.....	5,671	1,020,499	129
Total.....	39,824	6,077,939	153
So. Dobrogea.....	2,983	387,344	127
Grand Total.....	42,807	6,456,273	150

97 places were classified administratively as towns of which 29 had 10,000 or more inhabitants in 1934.

1943 estimated populations of the largest cities are:

Greater Sofiya.....	500,000 (405,727 in 1939)
Plovdiv.....	135,000 (125,000 in 1940)
Varna.....	80,000 (75,000 in 1939)
Ruse.....	55,000 (52,000 in 1939)
Burgaz.....	53,000 (51,000 in 1939)

Pleven.....	35,000 (31,520 in 1934)
Sliven.....	33,000 (30,571 in 1934)

About half of the Bulgarian urban population lives in these seven cities (see Chapter V).

The representative town has 7,000 to 10,000 inhabitants. In 1934, the 5,654 villages in Bulgaria ranged in population from 50 to 11,882 (Knezhza), the representative village having 1,000 inhabitants.

B. Ethnic groups.

(1) *Racial origin.* The Bulgarians, who form 86 per cent of the total population, are essentially Slavs, closely related to the other South Slavs of the Balkans.

In addition to the small Bulgar tribes of Turko-Tatar origin, the Slavs have absorbed Thracian, Greek, Roman, Germanic, and Asiatic ethnic groups which at one time or another inhabited Bulgarian territory. The only large ethnic group not absorbed is the 648,000 Turks (pre-war frontiers only) who were moved to Bulgaria during 500 years of Turkish dominion in the Balkans (prior to 1878).

The ethnic composition of Bulgaria in 1942 was:

Bulgarians.....	5,475,000 (86.1%)
Turks.....	648,000 (10.2%)
Gypsies.....	85,000 (1.3%)
Other.....	167,000 (2.4%)

Total population..... 6,357,000 (100.0%)

(2) *Size and concentration.* The Turks live in compact settlements in the Burgaz, Stara-Zagora and Shumen regions (*oblast*) and in the Dobrogea only. There some districts are as high as 90 per cent Turkish. Most cities have a Turkish quarter; Shumen is the Turkish religious and cultural center. The group has had a degree of judicial and cultural autonomy. Though the Turkish minority is not ardently nationalistic it has been used often to create tension between Bulgaria and Turkey. This friction is increased by the additional 150,000 Pomaks, Bulgarians who were Moslemized by force in the 17th century. They lived mainly in the Rodopi Planina (Rhodope mountains) and speak Bulgarian.

The Gypsies are mostly Moslem. Both sedentary and nomadic groups are present, and they are subject to the anti-Jewish laws.

The Jews (44,000) are mostly Spanish-speaking. 97 per cent live in towns and are mostly professional men, merchants and shopkeepers. Under stringent anti-Jewish laws, Jews from the five largest cities have been evacuated to smaller towns and large Jewish business interests have been liquidated.

The Rumanians (20,000) are concentrated in villages near the Danube River. The Rumanians in the Dobrogea have been exchanged. The Kutso Vlachs (15,000) are Christian, nomadic, mountain people, akin to the Rumanians, who live in southern and western Bulgaria.

The Macedonians are a minority in a restricted sense. They include the population of Bulgarian Macedonia and refugees from Greek and Yugoslav Macedonia. Other unimportant ethnic minorities are Armenians, Tatars, Gagauzi, Greeks, Russians, Germans and Czechs.

92. Population—Cultural Characteristics

A. Language.

(1) *Major, minor and official languages.* Bulgarian is a Slavic language using the Cyrillic alphabet and was spoken

in 1942 by 90 per cent of the people. It is understood by most of the minority groups; the Turks are the most important exception. Many older Bulgarians have a smattering of Turkish and Greek and Bulgarians with a high school education know some Russian and German or French.

The official language is Bulgarian, and its teaching is compulsory. Turkish is used in Moslem religious courts.

The languages known in Bulgaria are:

Bulgarian.....	5,821,000
Turkish.....	800,000
Rumanian.....	100,000
Gypsy (mixture of Turkish and Bulgarian).....	85,000
German.....	63,000
Greek.....	44,000
French.....	40,000
Albanian.....	35,000
Judeo-Spanish.....	30,000
Armenian.....	25,000
Russian.....	25,000
English.....	20,000
Kutso-Vlach.....	15,000

(2) *Dialects.* In addition to the literary Bulgarian taught in all schools there are two principal dialects, that of western Bulgaria and Macedonia, similar to Serbo-Croatian, and that of eastern Bulgaria, more like the literary language and Russian. Differences are small and Bulgarians have no difficulties understanding one another.

(3) *Knowledge of English.* Satisfactory dealing with average urban and rural inhabitants requires the use of interpreters. Some English is spoken by at least 20,000 people in Bulgaria and 10,000 know it well. Graduates of American missionary schools and language classes are in cities, while in most towns and villages there are immigrants returned from America who speak a few words of English.

B. Religion.

Over 84 per cent of the population belongs to the independent Bulgarian Eastern Orthodox State Church. This is similar in creed and organization to the Russian, Greek, Rumanian, and Yugoslav Orthodox churches.

The only large religious minority is the Moslems, including Turks, Pomaks, Tatars, and some Gypsies and Albanians; they form 12 per cent of the population. Two exceptions to religious freedom are the drastic anti-Jewish laws promulgated during the present war and the occasional artificially induced disturbances between Bulgars and Moslems. Otherwise the Bulgarians have permitted every religion complete religious freedom within the limits of existing laws. Hence, a great variety of Christian and non-Christian sects have flourished. Jurisdiction over churches other than the State Church is exercised by the Ministry of Foreign Affairs and Cults.

The 1934 population distribution by religions was:

Eastern Orthodox.....	5,128,890
Moslem.....	821,298
Jewish.....	48,398
Catholic.....	45,704
Gregorian (Armenian Orthodox).....	23,476
Protestant.....	8,371
Others.....	1,802
Total.....	6,077,939

C. Temperment and attitudes.

(1) *General.* Bulgarians generally are a sober, frugal, thrifty and industrious people. They abhor waste and ostentation. Conservative and cautious in most matters connected with everyday life, they have a traditional love of freedom and take to all kinds of causes and reforms with a crusading and often misguided zeal.

Bulgarians are independent and opinionated; political parties split up into innumerable factions and the most illiterate peasant is likely to have very definite ideas on how the country should be governed. However, discipline and authority have undisputed place in the family and in the village, where the village elders' words are law. Communal ownership of rural property is widespread and co-operatives are popular in both town and village.

Bulgarians are honest, generous, and very hospitable, except as Turkish brutality and the struggle for existence has taught them cunning, sharp practices and bargaining. They have a fondness for litigation, a passion for owning a house and especially land, and an ardent desire for education for themselves or their children.

(2) *Toward law and order.* Bulgarians tend to associate government with oppression and to mistrust it as a result of Turkish domination. Hence the policeman is obeyed but feared, and the paying of levies, taxes and fines is avoided.

Bulgarians are relatively law-abiding, largely because such a high percentage of the population owns property. Most communities are small and every irregularity of conduct is known and disciplined by social pressure. The absolute authority of the family elder contributes to the maintenance of general discipline. The village watchman has unwritten authority to shoot at trespassers. Curfew observance is enforced at 8 P.M. for persons less than 20 years old. Students wear uniforms for recognition purposes.

All Bulgarians are required to carry an identification card issued by school, commune or police. Strangers must register within three days of entry. These precautions are a means of political control, of apprehending and controlling the movement of subversive elements, and of preventing and detecting crime.

(3) *Military ability.* Bulgarians are among the best Balkan soldiers. The Army has been conscript since 1923, despite League of Nations prohibition, and is held in high esteem within the country. It received the best physical material and the less fit conscripts went into the labor corps. Promotions are strictly on a merit basis. Bulgarian soldiers are brave, rugged, well trained.

Bulgarians believe they never lost a battle. Almost the only opponents Bulgarians respect are the Serbs, who possess soldierly qualities and the same skill with the bayonet on which Bulgarians pride themselves. They despise Rumanians and before the recent Albanian campaign despised the Greeks. On occasion, as in 1923 and 1934, the Army has acted as a rather reactionary political force.

(4) *Alien ties.* Pan-Slavism is the strongest tie. It is manifested in the affinity for Russia and in an underlying desire for good relations with Yugoslavia. Ties with Germany are due to economic pressure and mutual interest in changing frontiers but suspicion and friction characterize German-Bulgar relations.

~~Confidential~~

93. Health and Sanitation*

A. Public health.

Public health in Bulgaria was very poorly developed prior to the last decade. Conditions in many parts of the country were almost exactly as they had been during the old Ottoman Empire and sanitary facilities were almost absent. In the last decade the entire public health policy has been improved under the guidance of the Directorate of Public Health, yet present facilities are highly inadequate. Hospitals do not nearly suffice in number or capacity. Physicians are few and are poorly distributed. Water is inadequate in amount and commonly polluted, so that water-borne disease is common. Water supply systems exist only in a few of the largest cities but even these cannot be relied upon as safe (see Chapters V and VI). Sewage treatment systems are entirely absent. Soil pollution and stream pollution are nearly universal and night soil is used as fertilizer. The incidence of preventable disease and the infant mortality rate are high.

B. Diseases.

Diseases of greatest military importance are: malaria, typhus, the enteric infections (typhoid fever, paratyphoid fever, bacillary and amebic dysentery, and the common diarrheas), the venereal diseases (especially syphilis and gonorrhoea), and the acute infectious diseases (scarlet fever, diphtheria, respiratory infections). Less common or less important are papataci fever (sandfly fever), anthrax, worm infestations (including echinococcus disease), and rabies. Also of potential military importance are relapsing fever, trench fever and dengue.

Insects important in the spread of disease include certain mosquitoes which breed in running water and others which breed in stagnant water, lice, sandflies, flesh flies and botflies, the Goblitz fly, the dog tick, and the itch mite.

C. Precautionary recommendations.

The following recommendations for personnel operating in Bulgaria are intended to supplement general sanitary precautions ordinarily in force in all areas.

(1) *Water supply.* All water supplies (including municipal supplies) should be considered unsafe and should be accepted only after proper treatment or bacteriological tests have been frequently performed.

(2) *Sewage.* The sewage disposal systems of Bulgaria may be regarded as non-existent. Hence, it will be necessary to arrange for local unit disposal wherever troops are stationed.

(3) *Malaria control.* Malaria is endemic in four main areas: the Danube region, the Black Sea coast, the Struma valley, and the Maritsa region. The incidence is highest in the Struma and Black Sea areas, less in the Maritsa, and least but not inconsiderable in the Danube region. The malaria season extends from May to October, reaching its peak in the late summer.

Control measures are at the discretion of the surgeon and should include:

- (a) The use of bed nets, repellents and protective clothing.
- (b) Screening and spraying of military buildings. Spraying may be conveniently accomplished by means of the Freon aerosol bomb. It will also be desirable to use this device in

*For detailed information see Appendix II.

any civilian buildings which may be frequented by military personnel.

(c) The installation of mosquito doors, which open against the wind.

(d) Treatment of mosquito breeding sites. Probably the use of Paris green will be more convenient than the use of oil. Special attention must be given to slowly running streams. The desirability of more fundamental procedures such as drainage and filling will depend on the military situation.

(e) Drug prophylaxis. This should be administered according to the method recommended by the Office of The Surgeon General, with modification according to circumstances.

(f) Judicious selection of camp sites. If possible, sites should be at least two miles from and higher than the breeding places.

(4) *Typhus.* The administration of typhus vaccine should not be omitted. A continuous and vigorous campaign must be waged against the body louse since this insect transmits typhus (and also relapsing fever and trench fever). Measures recommended are:

(a) Enforcement of personal cleanliness to the utmost possible under the circumstances. Ample facilities for bathing and laundering will be urgently necessary.

(b) The use of special delousing powder, to be dusted into the clothing. This powder is an item of general issue.

(c) The use of steam disinfection should not be necessary if (a) and (b) can be observed properly.

(d) Avoidance of contact with the native population.

(5) *Food and food handlers.* Diarrheal diseases and intestinal infections are extremely common in Bulgaria. The following measures are recommended:

(a) Strict supervision of food handlers.

(b) Avoidance of local supplies of food and water except when adequate treatment is possible. Locally produced ice is to be avoided under all circumstances. Troops should be warned against eating uncooked vegetables and berries.

(c) Strict supervision of local restaurants. These should be declared out of bounds if circumstances warrant such action.

(d) The control of flies by means of screens, sprays, flypaper and swatting. Attention should be given to manure heaps and similar breeding places.

(e) Privies and latrines should be screened and must be kept clean.

(6) *Venereal diseases.* Venereal diseases are especially prevalent in the seaports. A campaign of education and prophylaxis is recommended. Much of the success of the prophylactic campaign will depend on the availability of prophylactic devices, and on the accessibility and efficiency of prophylactic stations.

(7) *Acute infectious diseases.* Diphtheria, scarlet fever and epidemic meningitis have been unusually prevalent in Bulgaria during recent years. The following measures are recommended:

(a) Since crowding is an important factor in the spread of these diseases, ample space should be provided, especially in barracks and also in mess halls, theatres, and other places where men may congregate.

(b) Men who actually have developed one of these diseases should be isolated promptly and their clothing, bed linen and mess equipment disinfected.

(c) Civilian areas should be declared out of bounds if an outbreak is in progress. During such times civilians should be forbidden to visit the army posts.

(8) *Sandflies*. Sandflies carry papataci (sandfly fever), a disease capable of causing a high ineffective rate in military personnel. The insects are too small to be restrained by ordinary mosquito netting and the special fine netting (45 to the inch) is frequently avoided or rejected by soldiers. Vegetation and rubbish should be cleared for an area of 300 yards from barracks and other buildings. So far as possible any old crumbling walls or ruins should be removed. Crevices should be filled. Buildings should be sprayed by means of the Freon aerosol bomb and the grounds should be oiled for 300 yards from the buildings.

(9) *Rabies*. In Bulgaria, rabies occur in human beings, dogs, cats, cattle, and pigs. Dogs are unusually numerous. It is recommended that the keeping of pet animals be forbidden, and that any dogs found on military reservations be removed. Men should be instructed that in the event a soldier is bitten by an apparently rabid animal, the animal should, if possible, be taken alive and turned over to the Veterinary Corps Officer.

94. Social Structure and Social Conditions

A. Social groups.

(1) *Size, importance and influence*. Over 80 per cent of the Bulgarians are peasants or have a peasant outlook, as evidenced by survival of village customs, costumes, and to a certain degree mentally, although these are beginning to give way with twentieth-century progress.

In Bulgaria there is no titled aristocracy or ruling class. Class distinctions are slight and there is only a small middle class. Some families have acquired a certain prestige through long public service, but ancestry generally is not important. The present social cleavage is between the urban middle class and the peasants. Politically these two groups mistrust each other and struggle for domination.

Cutting across both major divisions a new proletariat is arising. It is composed in the rural areas of agricultural workers or peasants whose holdings have dwindled in size through subdivision, and in the towns of the intellectual and industrial proletariat. In either case, the result of poverty may be adoption of an ill-defined communist doctrine. At the other extreme, although there are no large individual land owners, there are a few relatively very wealthy individuals.

Finally, the number of state employees, most of whom are poorly paid, is large and out of proportion to the total population. Their ranks are fed by those with higher education who find the professions overcrowded and disdain business or agriculture.

(2) *Standards of living*.

(a) *General*. Bulgaria is a relatively backward and poor agricultural country. Living conditions are generally primitive and standards are low. The adoption of modern conveniences has been delayed to a great extent by thrift and

conservatism. The per capita wealth in 1939 was only \$400.

The staple food is dark sour-yeast-dough bread. The average daily per capita consumption was about two pounds in 1936. Some 65 per cent of all bread was baked in home ovens. The war-time ration has been as low as three-fifths of a pound plus a flour ration bringing the total to one pound. Most other foods are supplementary to the bread diet, e.g., cheese, olives, navy bean soup, stews, salads, and fruits. In the villages and smaller towns, roasts, pastries, and other cooked dishes are reserved largely for festive occasions. Pork, lamb and poultry are the principal meats; and fats, often deficient, are sunflower and vegetable oils.

Since the war started Bulgaria has fared better than most European countries, for, despite strict rationing and shortages in consumer goods, inflation has been checked and food has been sufficient.

(b) *Rural*. The average annual budget for a peasant family of six persons is about \$240 in cash and kind. About 70 per cent consists of home-grown products consumed by the family.

Virtually all peasant clothing is prepared from coarse home spun materials or home prepared skins and leather. Sheepskin coats and caps are important items, and pigskin or moccasins of reclaimed rubber are the universal footwear.

Villages are compact but unplanned. Hedge or mud fences enclose large yards and keep in the animals, who generally share the houses. The representative peasant habitation is a two-room, single-story house of mud brick with a thatch or tile roof. Floors are usually clay or dirt, but are kept clean. Furnishings are limited to a few benches and rugs and some copper and clay cooking utensils. Water often has to be obtained from public fountains, distant from the houses or villages. Only about 20 per cent of the rural population (about 850 villages) are provided with reasonably adequate water supplies. In 1941 about half the villages had electricity; kerosene and candles were used in the rest. Wood and charcoal are the chief fuels. Sewage systems are rare and sanitary arrangements are extremely primitive.

(c) *Urban*. Living conditions in the small towns (most Bulgarian towns are small) do not differ greatly from those in the villages. Many town dwellers are agriculturalists. Modern conveniences are usually lacking. The annual income of the average family may be \$400.

The food is virtually the same as in the villages, except that more meat and particularly rice dishes are used. Much of the cooking is done in public ovens. The diet of the poorest classes and of day laborers generally is often no more than bread and cheese, onions or dried herbs (*chubritsa*).

Clothing worn by townspeople is usually hand made from domestic materials.

In appearance there is little difference between a small town and a large village. Town houses have wood frames, with stone, brick or plaster walls. Roofs are tile or slate (in the mountains). Only the largest cities have running water, sewage systems and inside toilets. Central heating is almost unknown in the towns. The larger towns are supplied with electricity; elsewhere kerosene lamps are used. Usually there is an enclosed yard or garden adjacent to each house. Coal, charcoal and wood are used for fuel.

The most modern housing is to be found in Sofiya, Plovdiv, Varna, and Ruse. Sofiya has many large co-operative apartment houses.

~~Confidential~~**B. Stability.**

(1) *Internal tensions.* Bulgaria, being very homogeneous, has a minimum of internal tension. The mutual urban-village mistrust is the only important tension.

Even though most persons have peasant relatives, in a short period the civilizing influence of the city has caused economic and social differences which have created a rift between village and city. Urban inhabitants, whether doctors, teachers, or business men, dislike working in the villages, and when they do, they frequently try to exploit and boss the peasants. Bourgeois political parties have been in power most of the time, and their relative disregard of the peasants, coercion exercised at the polls, and a tradition of broken election promises have increased the tension. However, since 1931 the relationship has improved to a point where serious trouble is not to be expected.

The underpaid working class has been growing more powerful and in the event of a Bulgarian military defeat might start a revolt against the civil servants and the wealthier urban groups.

(2) *Reaction to crisis.* Bulgarians emotionally are both stable and unstable. They will fight patiently throughout a lengthy war as long as they approve of the goal, and they suffer national tragedies with a calm fatalistic attitude. In political arguments or when aroused over the supposed injustices of the Versailles settlement, they have shown violent fits of passion.

C. Education.

(1) *Facilities.* Education is compulsory between the ages of 7 and 14, though facilities are not available for a small portion of the 11 to 14 group. Over half of the teachers are men.

Out of a total of 679 foreign schools in 1939, 526 were Turkish elementary schools, 33 Jewish, 5 Roumanian, and 20 Armenian schools. All were supported by the government and operated for the respective ethnic groups.

The Germans, French, Italians, Americans and others have maintained some 88 missionary and propaganda schools, attended largely by members of the Bulgarian upper classes. The seven American schools have taught an average of 1,000 students a year.

(2) *Illiteracy.* Bulgaria, compared to other Balkan states, has a relatively high degree of literacy. The Turks, Tatars, Gypsies, and Bulgarians over 50 years old are the only large groups with a high percentage of illiterates. In 1934, about 19 per cent of the urban population and about 35 per cent of the village population was illiterate.

D. Labor.

(1) *Supply and capacity.* The ratio of labor force to total population was about the same for 1942 as 1934. The 1942 labor force was approximately 3,400,000 persons and was divided as follows: 81.43 per cent in agriculture, hunting and fishing; 11.79 per cent in industry, mining and handcrafts; 4.45 per cent in commerce, banking and finance; and 2.33 per cent in communications and transport.

Table IX-2 indicates the labor distribution by industry or occupation in 1934. Relationships shown in this table were similar in 1942 as the total persons engaged was only slightly higher than the total engaged in 1934.

TABLE IX - 2
BULGARIA, LABOR DISTRIBUTION
BY INDUSTRY, 1934

INDUSTRY OR OCCUPATION	NUMBER OF ESTABLISHMENTS	TOTAL ENGAGED	MEN
Agricultural labor.....	693,009	2,711,338	1,318,463
Mining, quarrying, salt working..	642	10,163	10,088
Metallurgy, manufacture and repair	12,325	35,926	33,154
Manufacture of motors and apparatus including electrical.....	516	1,705	1,654
Precision tools, jewelry, optics and galvano plastics.....	706	1,584	1,492
Vehicle production.....	6,316	13,174	13,131
Ceramics, glass, stone cutting, cement.....	2,988	9,787	8,978
Woodworking.....	11,199	35,198	31,186
Textile industry.....	8,843	30,215	12,483
Rubber.....	112	1,272	929
Leather and animal products.....	1,458	5,244	5,037
Food, beverages and tobacco.....	19,287	42,482	32,269
Clothing.....	20,835	48,978	40,426
Chemicals.....	378	2,039	1,733
Paper.....	817	6,254	5,047
Building.....	958	34,482	34,445
Electric power, gas and refrigeration.....	282	1,638	1,607
Others.....	148	260	
Total.....	87,168	270,243	223,748
Danube and Black Sea shipping... ..	59	2,063	
Mail, telegraph and telephone operation.....	639	5,481	
Radio transmission and maintenance.....	6	69	
Total.....	704	7,613	
Commerce, banking, insurance... ..	45,177	80,904	74,637
Domestic and personal services, including health.....	25,226	85,777	50,397
Science, education, religion.....		40,943	25,493
Publication, administration.....		75,460*	72,627

Bulgaria has a surplus of agricultural labor. Attempts have been made to meet this problem by encouraging the growing of industrial or special food crops requiring much labor instead of the traditional grain crops. It is estimated that almost a million unskilled workers could be removed from agriculture without serious results.

The Bulgarian industrial laborer is very similar to a hand-craftsman. Of the 318,500 skilled and semi-skilled workers employed in 1934 about one-third were working proprietors, leaving an average of two to three workmen per industrial establishment. A few larger industries have grown up since 1934 but the basic situation has altered little.

The Bulgarian laborer is retentive, hard-working and clever with his hands. He can be employed in a skilled trade after a short training period. Therefore, the potential reservoir of mechanical labor among the poor agricultural population should be noted. Many people are being trained in efficient

*Including a standing army of about 30,000.

government technical schools where extensive machine-shop and practical work is given in many fields besides the specialty, so that graduates are very versatile. There are also trade schools for prospective workers.

(2) *Customary working conditions.* Labor is plentiful and rates of pay are exceedingly low. Agricultural workers receive food and up to the equivalent of 50 cents per day (one lev equals one cent). Unskilled industrial and building-trade laborers receive the equivalent of 35 cents to \$1.00 a day and skilled laborers up to \$2.00. The average pre-war income of a town laborer was \$18.00 to \$20.00 a month of which \$5.00 went for rent and \$10.00 for food; the average 1943 income has risen to \$30.00 to \$35.00, the rent to \$5.75 and the food costs to \$25.00.

Despite eight-hour-day legislation, the vast majority of workers are accustomed to working ten and 12 hours.

(3) *Organization.* Trade unions were strong before 1934, but since then workers and employers have been organized into the following seven nation-wide associations ('unions'): Industrial workers, agricultural workers, peasant proprietors, artisans, small merchants, merchants, and industrialists. All have functional subdivisions whose elected representatives form a pyramid from the commune through District and Region Councils to a National Union Council, all under government supervision. The organization is headed by a Directorate of Professions, responsible to the Prime Minister; it appoints all higher officials and has rosters of all workers and employers in the country. The unions have extensive employment recruiting facilities. No labor organization other than a government union is permitted and strikes are illegal.

The most common method of recruiting labor is through invocation of the compulsory labor laws. Every youth, on reaching 21, is required to serve eight months in the Labor Corps (*Trudovaki*). In addition, every adult man and woman is liable for 21 days a year of unpaid service to the community or state. In practice women are seldom called, and men generally serve less than ten days repairing roads and railroads, or working on drainage, flood control, or reforestation.

95. Governmental Organization

A. Locus of authority.

Bulgaria is in theory a constitutional monarchy with the King, the Ministerial Council (Cabinet) and the National Assembly sharing the power (Figure IX - 2). However, since 1935 King Boris assumed the powers of a dictator and worked through the Ministerial Council ruling by decree. The National Assembly generally gave approval. The Bulgarian constitution, which is among the most democratic, virtually has never been completely in force.

The Council of Ministers exercises supreme executive power in the name of the King and is responsible for internal and foreign policy. The ten ministers are collectively and individually responsible to the King and the National Assembly and all Council decisions must be unanimous. Theoretically, the Council depends for survival on votes of confidence by the National Assembly, but in practice the good will of King and Army, public opinion, and unanimity within the council determine survival.

The National Assembly has 160 members, elected by single member constituencies of from 20,000 to 40,000 inhabitants. About 140 of the members consistently support the government. The Assembly initiates legislation (sharing legislative power with the King), and approves laws, decrees, and orders issued by the government (all decree laws of the past eight years have been subsequently approved by the Assembly). It exercises financial control and approves ministerial budgets and other expenditures, ratifies treaties (usually *ex post facto*), interrogates any minister at any time on any act or policy, and passes on the legality of election.

B. Local government.

Since 1934, the country has been administered by 7 civilian Region directors (chiefs), 89 District Chiefs, and 1,215 Commune mayors appointed through the Ministry of Interior and subject to removal. The other ministries maintain parallel hierarchies for the administration of their particular domains. Administrative regions (*oblasts*) as established in 1934 are given on Figure IX - 1.

Since the return of Dobrogea, it has been joined with a small portion of the former Shumen Region, to form a new Ruse Region. Acquisition of Yugoslav and Greek territory has brought the creation of 3 new Regions: Skopie (18 Districts), Bitolia (6 Districts), and Aegean (9 Districts). Four Districts have also been added to the Soliya Region.

The relation of local and central government is given on Figure IX - 2.

C. Efficiency.

The Bulgarian government, by Balkan standards at least, is very efficient. This is because of the tight centralization of the administrative machine, the employment of trained men in technical departments, and the appointment of qualified lawyers as mayors. However, from the German viewpoint the government is often hopelessly inefficient.

The administrative officers tend to be more harsh than the former political appointees, but most instances of bureaucratic abuse of authority and corruption by officials are severely punished.

The Region Director, as representative of the Ministerial Council, coordinates the activities of the Region medical officer, engineer, police chief, agricultural school inspectors, economic adviser, the officials of the regional labor organizations, and other representatives of the ministries and semi-autonomous directorates. The District (*Okaliv*) chiefs and the mayors coordinate the work of representatives of the same agencies at a lower level, and form a connection between the Prime Minister and the village clerk; this permits the Prime Minister to keep in close touch with activities of every branch of government.

96. Security and Public Order

A. Police.

(1) *Regular.* The Bulgarian police organization consists of the Directorate of Police at the Ministry of Interior, the Region and District police services, and special services on a par with District service in towns having a prefecture of police. A government police inspector is attached to the civilian director of each Region and a commissar of police

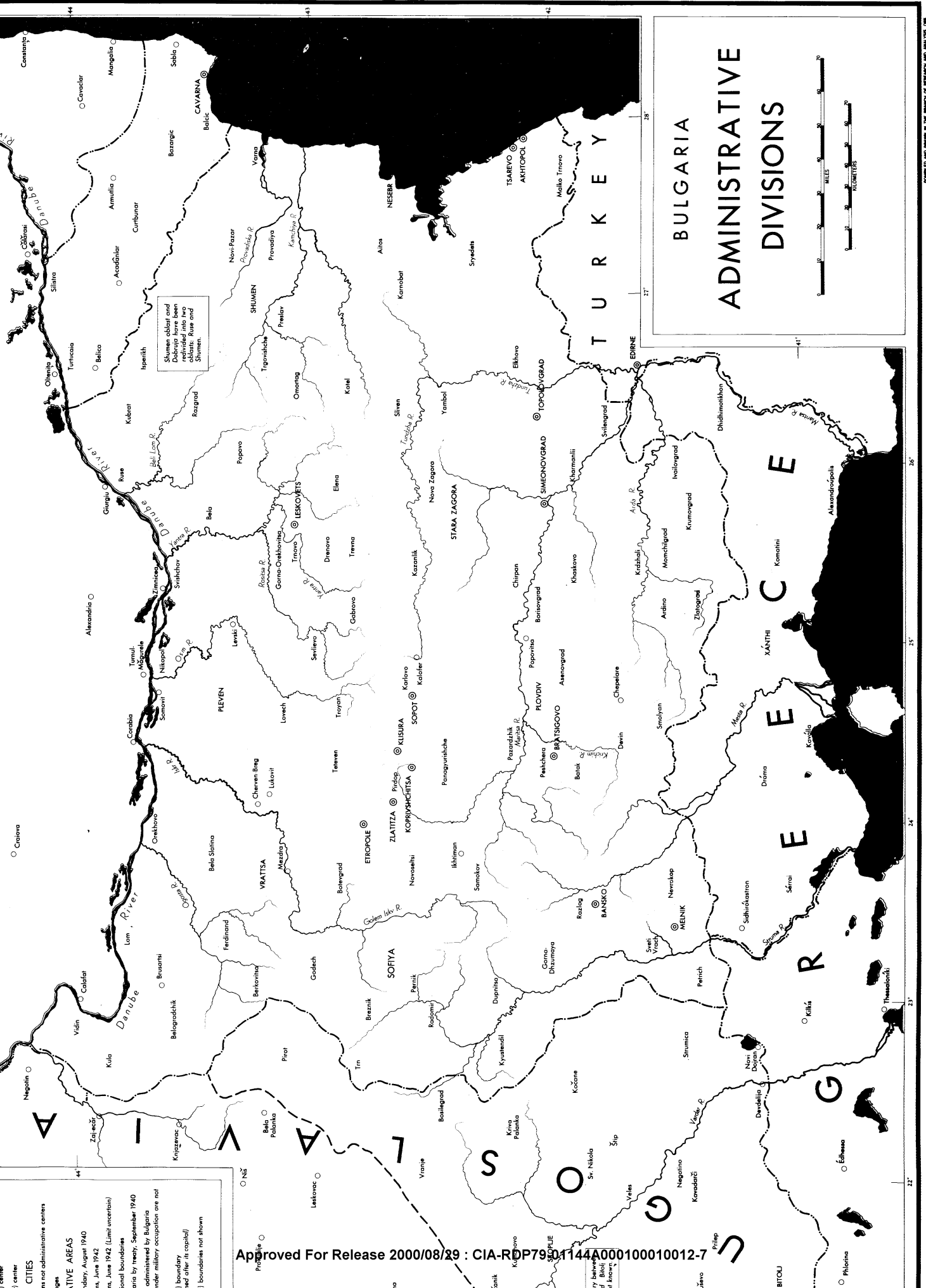

Skumen oblast and Dobruja have been added to the administrative map and Shumen.

BULGARIA ADMINISTRATIVE DIVISIONS



COMPILED AND DRAWN BY THE BRANCH OF RESEARCH AND ANALYTICAL USE

NATIONAL AND LOCAL GOVERNMENT IN BULGARIA

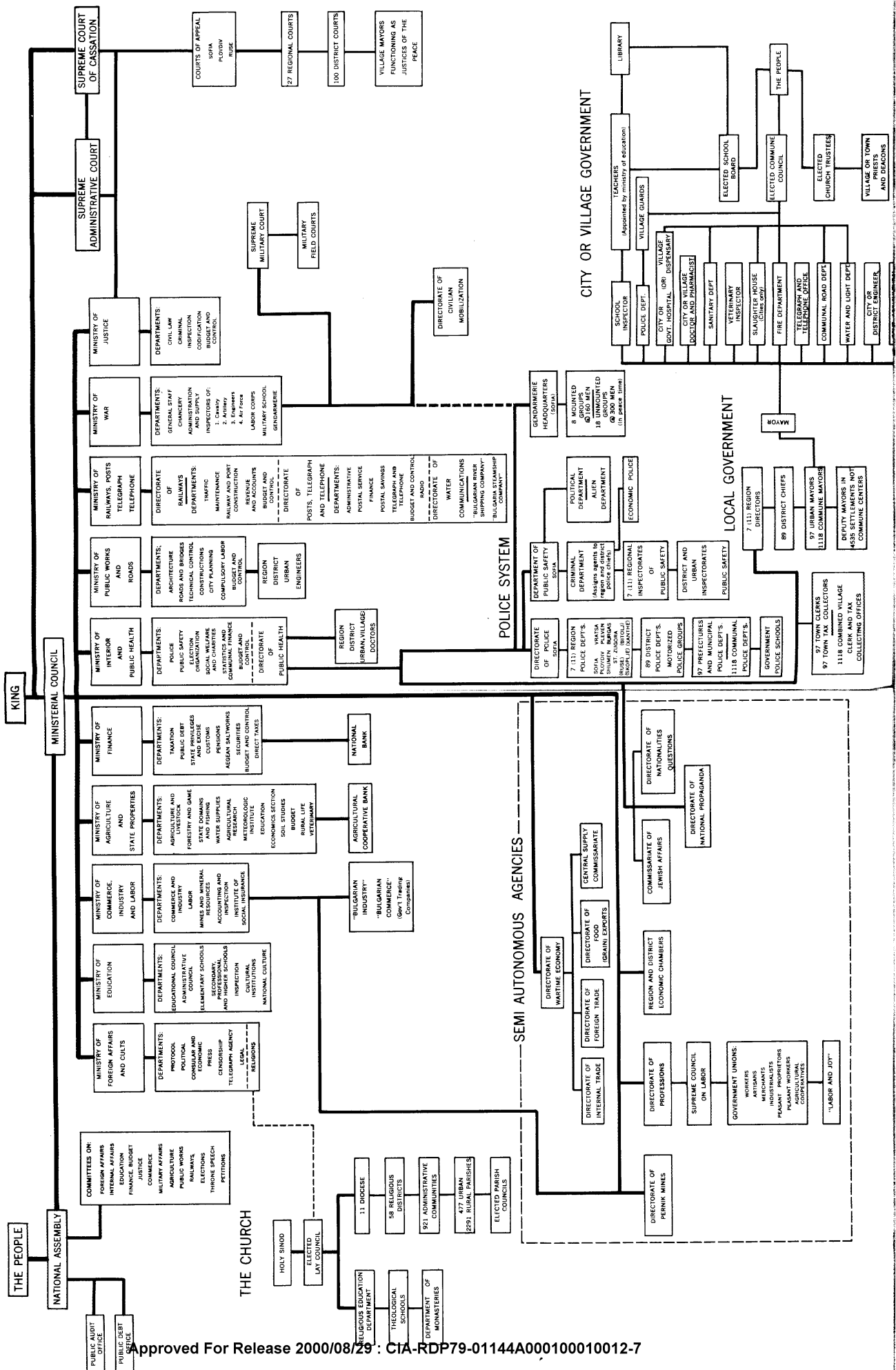

to each District civilian chief. Each village and small town normally has from one to three policemen. Since 1934, most local police have been appointed by the central government. There is no system of sheriffs and deputy sheriffs (as in the United States) but posses are used to trail armed bandits. The pre-war police force had 6,200 men.

A *gendarmerie* supplements the regular police. It is officially under the Ministry of Interior, but organization, management, and staff are supplied by the Ministry of War. It includes mounted and infantry units (Figure IX - 2).

Bulgaria's police system has suffered from too many political appointments, but since 1934 it has been relatively efficient and effective. Judged by American standards its methods are brutal and its extensive use in political coercion has had a bad effect.

(2) *Secret*. Like the Directorate of Police, the Department of Public Safety is a branch of the Ministry of Interior with headquarters in Sofiya. Its criminal, political and alien departments operate through the regular city police departments and through the Region and District inspectorates which have uniformed and civilian operatives at their disposal.

A special wartime organization under the Criminal Department is the Economic Police Section, which assists authorities charged with administering economic regulations (including those concerning Jews) foreign currency control, customs laws, excise and state privileges, price control, graft among officials, illegal holding of property and civil mobilization.

B. Other officials with policing power.

(1) *Public health*. The commune doctors and veterinary officials are permitted to use local police forces for enforcing health rules. In times of emergency or in malaria-infested areas the Directorate of National Health (Ministry of Interior) organizes health battalions including doctors, nurses, labor corps men, and often police or army units which have extreme emergency powers.

(2) *Fire departments*. Sofiya, Plovdiv and Varna are the only cities with adequate and relatively modern mechanized equipment. Elsewhere single motor pumps or horse-drawn water tanks with hand pumps are generally used. All fire departments are municipal or communal, often on a haphazard volunteer basis, but with some government financial assistance. Yurii Zaharchuk, the Sofiya Fire Chief, acts as national inspector for fire fighting.

(3) *Air raid warning*. Bells are the chief alarm signal outside the cities. Blackouts are enforced. There is little anti-aircraft protection and still less in the way of shelters. The air raid warden service is under the army; civilian wardens are used.

C. Penal institutions.

In 1933 the principal prisons and their capacities were: Sofiya, 850; Sliven, 580; Shumen, 550; Plovdiv, 550; Khaskovo, 340; Trnovo, 280; Stara-Zagora, 250; and Pazardzhik, 250. Smaller prisons accommodating 50 to 100 are located at Berkovitsa, Burgaz, Vidin, Vratsa, Varna, Gorna Dzhumaya, Dupnitsa, Lovech, Nevrokop, Plevn, Razgrad, Ruse, and Sevlievo. Prisons are generally overcrowded; since April 1941 schools have been requisitioned to supplement them.

Penal camps for speculators and concentration camps for political offenders and Jews have been established near most of the small provincial towns. Military barracks, monasteries, resort hotels, or hastily constructed shacks are the shelters. There are larger camps at Lom, Asenovgrad, Gorna Dzhumaya, Sveti Anastasiya Island (Burgaz Bay), Varna, Xánthi (Greek Thrace), and Thásos Island.

D. Pertinent legal peculiarities.

Bulgarian justice, based on Roman law, is dispensed by panels of three or more judges. Juries are not used. The judicial system has three main branches: Civil-Criminal, Administrative and Military. Of these, the Supreme Administrative Court is comparable to United States Federal Courts, particularly in regard to decisions on the constitutionality of laws.

Military courts function permanently only in wartime and try all cases of violations against the "Law of the Protection of the State." This law is directed against the Communists and is drastically enforced. Capital punishment is by hanging.

97. Political Factors

A. Political organizations.

(1) *General*. On June 14, 1934, the National Assembly was dissolved, political parties were abolished, and formation of new ones was declared illegal. Until May, 1938, the country was ruled by ministerial decrees, countersigned by King Boris; cabinets were composed of independents and a few former party leaders. On October 21, 1937, a new electoral law attempted to restore parliamentarism without political parties by substituting single member constituencies for party ballots and proportional representation. In the elections held in 1938, old-time politicians were eligible for election as independents, despite the continued ban on parties. As a result, former premiers, ministers and party leaders were included in subsequent assemblies, retained their following and made under-cover election deals. The power of these one-time political leaders and their party organizations cannot be discounted as a latent force today. Most are still in responsible government and private positions and would be able to muster a following.

(2) *Dominant political parties*. Principal groups are: old bourgeois ("law and order" parties), peasant parties, communist and socialist parties, and chauvinist-fascist parties (including the Macedonian group).

(a) *Bourgeois parties*. Bourgeois parties, which unite in keeping the government out of the hands of the peasants, are the: Radical Party, composed of "satisfied" people, bankers, merchants and wealthy villagers, which advocates democratic reforms; National Liberal Party, champion of Macedonian aspirations and responsible for Bulgarian entry into the First World War, composed of conservative bourgeois elements; Democratic Party, composed of moderate middle-class elements and younger intellectuals, which was the strongest bourgeois party in 1934; and the Democratic Entente which represents big business, the conservative middle class, and intellectuals, and which was in power from 1923 to 1931.

(b) *Peasant parties*. The peasant parties wish to destroy the power of towns over villages and introduce agrarian reforms. They are: the Agrarian Party, representing the interests of the peasants, which was in or shared power from 1919

~~Confidential~~

to 1934, and is often radical and pro-Russian; and the National Peoples Agrarian Union which is extremely class conscious, and works for a union with Yugoslavia. Members of the latter are known as "Pladne" Agrarians. Both Agrarian groups maintain close relations with Machek's Croatian Peasant Party.

(c) *Socialist and communist parties.* The Social Democratic Party believes in peaceful change and state socialism and has participated in bourgeois governments. Its members are intellectual Marxists and include the small industrial proletariat. It is a small but vocal group, usually in the opposition. At one time it united with the Communist Party.

The Workers Party (communist) was the unofficial Bulgarian section of the Third International and received subsidies and instructions from Moscow. It was strongest from 1918 to 1923 and from 1931 to 1933. After winning the Sofiya municipal elections in 1933, the Communists were suppressed. The party includes proletarians, leftist agrarians, unemployed intellectuals, university students, and bourgeois Soviet-sympathizers. It has a strong youth organization with secret cells. The Communists, together with many sympathetic bourgeois and peasant groups, have led the only active opposition against the present government.

(d) *Chauvinist-fascist parties.* The National and Social Movement composed of the personal following of Prof. Alexander Tsankov, ultra-nationalistic university and high school students, and Macedonians, is the only truly fascist party. Its youth organization "Ratnik," was modeled on the Nazi pattern. The main appeal was revisionism and opposition to Bulgarian-Yugoslav understanding. "Ratnik" has now been superseded by a new government-sponsored national youth organization "Bramnik," even more Nazi in form. Tsankov has the support of the "Vulkovists," the more chauvinistic among the active and reserve military and the "Supremist" Macedonians.

Though not an official party, the Macedonians have elected members to parliament since 1927. The majority of this vote came from approximately 250,000 Macedonians in southwest Bulgaria. In this area and prior to 1934 the Internal Macedonian Revolutionary Organization (I.M.R.O.) forcefully maintained a state within a state; appointed officials, teachers, and judges; collected taxes; and murdered local members of the assembly elected without their sanction. Additional votes came from Macedonian refugee organizations scattered throughout the country. Their political strength lay in their unqualified revisionism and their constant use of threat and assassination to prevent Bulgarian-Yugoslav understanding. They have been used and paid by Italy and Germany to nullify Balkan solidarity efforts. The I.M.R.O. was broken up between 1934 and 1940 but has since regained its power; its leader is Ivan Mihailov. A smaller "Protogerovist" faction is strongly pro-Russian and pro-Balkan federation.

(3) *Minor political parties.* Small parties are largely factions of the large parties and vary from election to election. Such factions, each usually the following of one disgruntled politician, are represented at most by one or two men in the assembly. Each has a following of about 5,000 to 10,000.

The Officers' League (also called the Military League), an organization of active army personnel, has always been a powerful force. In 1923 and in 1934 it overthrew the existing regimes by force and actively engaged in government. It is officially disbanded.

The Reserve Officers' League, like the Officers' League, is potentially powerful. Most of its members belong to the bourgeois parties. They are revisionists, usually working with the Officers' League, and assisted in the 1923 and 1934 coup d'états. Under war conditions, it is hardly distinguishable from the Officers' League.

The "Zveno" Group includes intellectuals advocating radical social and parliamentary reforms and friendship with Yugoslavia; it has opposed political persecution and Macedonian terrorism. It joined with the Military League in taking power in 1934 but dissolved itself in the fall of 1934. Its leaders probably still favor Balkan federation.

Racial minorities have only local political importance. They are principally Jewish, Turkish, Pomak, and Greek. Gypsies cannot vote.

(4) *Pro-United States political groups.* The Bulgarian people as a whole have always looked with respect and admiration toward America and American democracy. They believe in American idealism as expressed in Wilson's Fourteen Points, using it, however, to support their revisionism. Bulgarians realize that they owe their independence at least in part to the efforts of Americans, and that they would have been treated much more severely in 1918-19 if the United States had not intervened on their behalf.

Political parties as such have never had occasion to be pro or anti-United States. Their attitude in the present conflict depends on purely European considerations, including Russia's stand, Bulgarian economic dependency on Germany and internal forces for and against boundary revision.

The fight against Fascism and the subjugation of small states is the greatest common denominator of Bulgaria and the United States. Adherents of former parties which favored Russia and which worked toward Balkan or at least Bulgarian-Yugoslav unity (Social Democrats, Communists and Agrarians) should be considered pro-United States. Also, it should be noted that every Bulgarian is potentially a friend of Russia whether he agrees with Soviet ideology or not. Fear of revival of communism alone checks pro-Russian sentiment in Bulgaria.

Middle-of-the-road parties, Radicals, Democrats and Liberals, share the general friendly attitude toward the United States. But the attitudes of their leaders vary.

(5) *Anti-United States political groups.* These are Alexander Tsankov's National and Social Movement, the Macedonians who work with Italians and Germans in the hope of gaining independence, and the rather strongly pro-German and revisionist Liberals.

The "anti-United States" groups are too deeply committed to the "new order" as it applies to the present enlarged Bulgarian frontiers to allow their potentially friendly or at least neutral attitude toward the United States to manifest itself.

B. Current trends in foreign policy.

Bulgaria's international position has been determined for a number of years by the fact that it has been a small, defeated, and demilitarized country whose economic life depended on finding outlets for surplus agricultural products. Therefore, the governmental policy has been to maintain a correct attitude towards neighbors and to cultivate good relations with those countries which could buy Bulgarian goods. At the



same time, Bulgaria has not renounced officially her claims for revision of the peace terms. The presence in Bulgaria of large, well-organized and vocal emigrant groups from Dobrogea, Thrace, and Macedonia made it difficult to maintain a policy of peaceful revision by negotiation under Article 19 of the Covenant of the League. Also, the attitude of Bulgaria's Balkan neighbors was unfavorable to revision by negotiation.

Bulgaria came into this war on the Axis side as a result of: German economic domination, Germany's success in changing frontiers (particularly the 1940 restoration to Bulgaria of southern Dobrogea), the impression of German invincibility gained from the first two years of war, the people's desire to avoid having their country become a battleground, the Allies' weakness in the Middle East, the presence of German troops in Rumania, and the fact that Russia and Germany were allied.

Disillusionment in Bulgaria began with the German attack on Russia and with the failure of the long-suffering Macedonian population to accept wholly the Bulgarian regime. The Bulgarian government has consistently endeavored, in its dealings with the Germans, to restrict its military commitments to occupation duties in Yugoslavia and Greece. The first active military move was Bulgarian participation in an Axis campaign against Yugoslav guerrilla forces in the spring of 1943. Bulgaria's economic collaboration has been complete, but general dissatisfaction was created by failure of the Germans to supply consumers goods and the law fixing prices paid for Bulgarian products.

Both people and government have become convinced that Germany will lose the war. Thus, the problem has been to leave the conflict by a method which takes into consideration basic national objectives. These are to: avoid breaking with the Axis as long as there is danger of a punitive expedition and German occupation; salvage a portion of the territories incorporated since 1940; avoid alienating Soviet Russia; keep Bulgaria from becoming a battlefield; avoid fighting outside of Bulgaria's frontiers; have a government that is neither reactionary nor communist. However, this does not mean that, when actually confronted by a Russian or British-American invasion force, Bulgaria will fight rather than accept unconditional surrender.

Pro-Russian feeling is perhaps the basic factor affecting

present foreign policy. In addition to the racial, linguistic and historical affinity for Russia, admiration for Russian military exploits, and the fear of British and American territorial commitments to Bulgaria's neighbors may cause any future government to adopt a pro-Russian orientation and Soviet protection. Bulgaria appears to be willing to accept Russia's declaration that she will be satisfied with any government that does not lean on any other Great Power.

In an effort to counteract the great Russian influence which pro-Russian orientation would entail, the government would endeavor to deal with liberal and agrarian elements in all neighboring countries to create a Balkan understanding and prevent one state being played against the others.

The Communist movement in Bulgaria will certainly be strengthened by a Russian orientation, but it will probably not become strong enough to assume power, except as part of a coalition government. Sabotage and fighting against Germans and pro-German Bulgarians will increase as elsewhere. Unless the Bulgarian armies are drastically defeated, there is little or no probability of a purely Communist revolution or Communist regime. The possibility of a Communist-Agrarian revolt should not be excluded if bourgeois groups take an anti-Russian stand.

In event of invasion the Bulgarian Army would hold the territories it now occupies until instructed by Russia. Its leaders have always hoped that if the Army can remain intact it will constitute a stabilizing influence in the Balkans, be used by the Allies to subdue leftist revolts and maintain order, and thus remain the strongest power in the area. A campaign to oust remaining German units is a possibility.

If Russia was not in a position to exert pro-Bulgarian pressure at the time of a British-American invasion, the Bulgarian government probably would attempt to make a deal short of unconditional surrender with Britain and the United States. This would permit Allied troops to pass through the country, or preferably to by-pass it, leaving Bulgarian manpower and economy intact. However, greater opposition would be offered at the present frontiers than if Allied movement had Russian sanction. Within the country, opposition groups, suspicious of British motives and commitments, would adopt an attitude of watchful waiting; the Communists might even try to start a revolt and establish a Soviet republic.