

~~CONFIDENTIAL~~

~~SECRET~~

Approved For Release 1999/09/02 : CIA-RDP79-01083A000100050001-3

Copy No.

PROVISIONAL INTELLIGENCE REPORT

SOVIET GEODETIC AND PHOTOGRAMMETRIC
INSTRUMENTATION



CIA/RR-ER-5

APRIL 1954

25X1A5a1

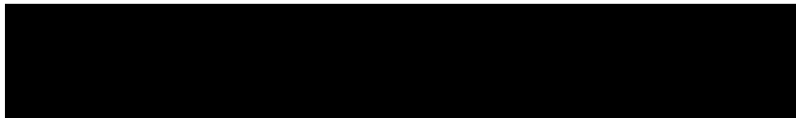

CENTRAL INTELLIGENCE AGENCY

OFFICE OF RESEARCH AND REPORTS

DOCUMENT NO. 1
NO CHANGE IN CLASS.
 DECLASSIFIED
CLASS. CHANGED TO: TS S
NEXT REVIEW DATE: 1989
AUTH: RR 702
DATE: 14/11/79 REVIEWER: 019360

Approved For Release 1999/09/02 : CIA-RDP79-01083A000100050001-3

1-115-311

~~SECRET~~

~~CONFIDENTIAL~~

WARNING

~~This material contains information affecting the National Defense of the United States within the meaning of the espionage laws, Title 18, USC, Secs. 793 and 794, the transmission or revelation of which in any manner to an unauthorized person is prohibited by law.~~

~~SECRET~~

PROVISIONAL INTELLIGENCE REPORT

SOVIET GEODETIC AND PHOTOGRAMMETRIC INSTRUMENTATION

CIA/RR-ER-5
APRIL 1954

CENTRAL INTELLIGENCE AGENCY

Office of Research and Reports

~~SECRET~~

FOREWORD

This report is one of a series prepared for an external research project entitled "The Problem of Soviet Capabilities in Geodesy and Cartography," which was sponsored by the CIA as an element of the research program of the ~~29X1451~~ ~~29X1451~~ Division, Office of Research and Reports. The project was carried

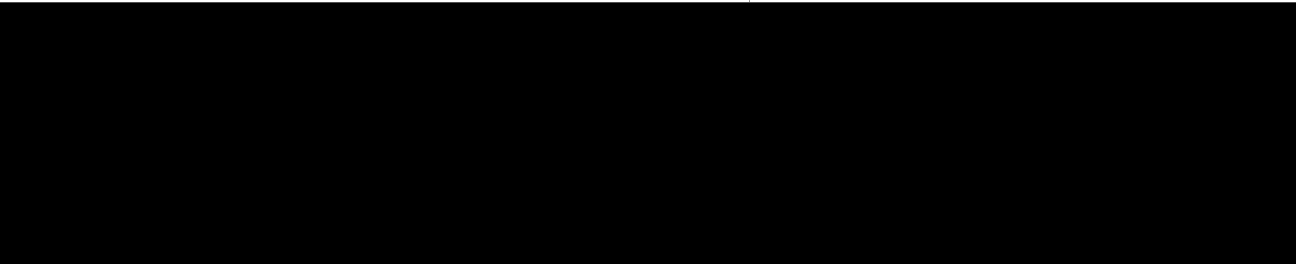

Inadequate knowledge of the status of Soviet developments in geodesy, photogrammetry, and cartography has been recognized as an intelligence deficiency, and intelligence reports in these fields are extremely few in number and limited in topical coverage. For these reasons, the Project was initiated to assess Soviet capabilities on the basis of a systematic study of all available published information on Soviet developments in geodesy, geodetic gravimetry, geodetic astronomy, geodetic and photogrammetric instrumentation, and cartography. The resulting reports are derived almost entirely from an extensive search for and an analysis of published Soviet scientific source materials.

The reports of the Project are designed not only to provide provisional information on the current status of Soviet capabilities in surveying and mapping but also to serve as a datum for a continuing program of collection and research that will in the future provide increasingly accurate and timely intelligence. The opinions and conclusions in ER-5, therefore, do not represent final CIA evaluation of Soviet capabilities in surveying and mapping.

Comments by users of the reports are solicited by the Geography Division. Other types of information resulting from the Project that do not lend themselves to publication are available for reference in the CIA Library. Among these are an extensive bibliographic file, a register of miscellaneous Soviet institutes and laboratories, and a biographic file.

This report (ER-5) is concerned with an analysis of Soviet capabilities in geodetic and photogrammetric instrumentation. The study is based largely on descriptions and claims in open-source Soviet materials. No attempt was made to consider the relationship of the East German capabilities, particularly in optics, to the overall Soviet capabilities in the field of geodetic and photogrammetric instrumentation.

Technical personnel interested in additional descriptive details concerning Soviet instruments may request, through established liaison channels, a research aid entitled Additional References to Soviet Diagrams, Sketches, and Photographs of Soviet Geodetic and Photogrammetric Instruments, CIA/RR-ER-6, SECRET.

Other publications of the Mapping and Charting Research Laboratory issued to date in the CIA/RR-ER series are:

Geodetic Gravimetry in the USSR, CIA/RR-ER-1, 18 October 1951. SECRET.

Deformation of the Crust of the Earth and Terrestrial Magnetism, CIA/RR-ER-2, 18 October 1951. SECRET.

Selected Bibliography of Soviet Studies in the Field of Cosmic Rays, CIA/SI 78-54, 2 March 1954. SECRET.

General Critique of Soviet Gravimetric Data, CIA/RR-ER-3, 15 April 1954. SECRET.

Review of Soviet Photogrammetric Procedures, CIA/RR-ER-4, May 1954. SECRET.

~~SECRET~~

Approved For Release 1999/09/02 : CIA-RDP79-01083A000100050001-3

ER's planned for later publication will discuss the organization of Soviet geodesy and cartography, leveling in the USSR, and Soviet education in geodesy and cartography, and will analyze Soviet geodesy and selected Soviet maps.

Approved For Release 1999/09/02 : CIA-RDP79-01083A000100050001-3

~~SECRET~~

CONTENTS

	<u>Page</u>
SUMMARY AND CONCLUSIONS	i
I. INTRODUCTION	1
A. Soviet Claims	1
(1) Training Centers in Optics	4
(2) Centers of Research	7
(3) Production of Optical Glass	8
(4) Factories of Geodetic and Photogrammetric Instruments	10
B. Limitations of Present Study	17
II. GENERAL CONCLUSIONS	24
III. SOURCES	28
A. Adequacy of Sources	28
B. Sources Examined	30
APPENDIX I. Photogrammetric Instruments	35
II. Geodetic Instruments	44
III. Gravimetric Apparatus	53
IV. Photographic Lenses and Cameras	59
V. Radio Instruments	78
VI. Soviet Astronomical Instrumentation	87
VII. Photographic Supplement	95

~~SECRET~~

Approved For Release 1999/09/02 : CIA-RDP79-01083A000100050001-3

This report is an attempt, almost wholly on the basis of open source material and without adequate opportunity to laboratory-test equipment, to arrive at a reasonable conclusion as to Soviet capabilities in this very restricted subject. Open-source Soviet literature reveals that the Soviets have at their disposal, not only a large number of well-trained personnel working in the field of applied optics, but also a corps of outstanding theoretical scientists and the laboratory and industrial facilities necessary to develop an efficient and successful optical industry.

The Soviet claim that they are completely independent of the West with respect to optical apparatus should be accepted with some reservations. Nothing very original in the field of optical apparatus has been found in Soviet technical literature, although some Soviet photogrammetrical lenses appear to be excellent, perhaps even superior in some ways to the Western lenses now in use.

Surveying instruments such as theodolites, chronometers, etc., appear to be adequate but no great originality is evidenced by the Soviets in this field. Some Soviet gravimeters, however, deserve careful attention.

The Soviet technical literature contains relatively little information dealing with their equivalents of Shoran, Loran, Radar, and other electronic instruments of Soviet manufacture. Of possible significance, however, is the fact that the Soviets began to pay attention to the use of radio instruments for surveying purposes earlier than did the Western nations.

The general conclusion is that the Soviet optical industry, in so far as geodesy and photogrammetry are concerned, is in a state of development comparable to that of the United States, with a difference in emphasis necessitated by different geographical and economic conditions and surveying goals.

Approved For Release 1999/09/02 : CIA-RDP79-01083A000100050001-3

~~SECRET~~

SECRET

Approved For Release 1999/09/02 : CIA-RDP79-01083A000100050001-3

I. INTRODUCTION

Analysis of construction of geodetic and surveying instruments in the U.S.S.R. involves study of much of the industry and technological development of that country and cannot be made intelligible without some attention to the general problem. This situation becomes clear if we consider the necessary prerequisites for the construction of any particular instrument, such as a camera for aerial photographic work. In order to construct such a camera, we must have:

- a. A designer who is expert in problems of geometrical optics. This involves considerable training at some scientific center.
- b. Availability of glass with very exact physical properties which can be produced only by a highly developed glass industry.
- c. Availability of metals, alloys and plastics required to give the camera the necessary rigidity and ease of operation. This involves consideration of much of the metallurgical and plastics industry.
- d. The availability of factories where all the necessary parts of the camera can be machined with the highest degree of precision and in standardized mass production. This involves consideration of Soviet light industry.

Therefore, some attention must be given to these general problems of Russian industry and technology even in discussing such a narrow subject as the production of geodetic instruments.

A. SOVIET CLAIMS

In the field of optical instruments, the more recent Soviet publications contain certain claims which may be summarized as follows:

- (1) The Soviets, starting from a state of complete dependence, have developed a tremendous optical industry

Approved For Release 1999/09/02 : CIA-RDP79-01083A000100050001-3

SECRET

SECRET

Approved For Release 1999/09/02 : CIA-RDP79-01083A000100050001-3
(2) The Soviet optical industry is just as good, and in some cases superior, to those manufactured abroad

- (3) The Soviets are now independent of foreign countries in optical instrumentation
- (4) There are many original inventions in Soviet optics

As an illustration of this attitude, the following statements are quoted here in free translation:

V. Ya. Mikhaylov in his textbook, "Photography and Aerial Photography", 1952, (1) says:

"In Tsarist Russia optical glass was not manufactured, and therefore optical systems were not designed or manufactured..... The first objective, 'Takhar', was designed by G. G. Slyusarev in 1924. At first the work of designers was limited to imitation of already-known designs, but in a short time original Soviet objectives began to be constructed.....

"In the last fifteen years considerably more new and original work has been done in the Soviet Union than abroad. Among the better-known original Soviet objectives are a series of wide-angle objectives called 'Russar', of which Russar-29 is especially interesting. This lens has considerably less difference in the degree of illumination between the center and the edges than is common in other wide-angle objectives, (designed by M. M. Rusinov); an even wider-angle objective called the 'Rodina', (designed by V. S. Rodin); objectives of the 'Uran' type (designed by D. S. Velosov) and the meniscus mirror objectives of D. D. Maksutov.....

"At the present time in the U.S.S.R. there are many dozens of photographic objectives of original construction. There are several plants manufacturing different sorts of optical glass"...

Approved For Release 1999/09/02 : CIA-RDP79-01083A000100050001-3

SECRET

SECRET

Approved For Release 1999/09/02 : CIA-RDP79-01083A000100050001-3

F. V. Drobyashev, in his textbook, "Photogrammetric Instruments and Instrumentation", 1951,⁽²⁾ has this to say:

"At the present time all kinds of photogrammetric instruments are manufactured in the Soviet Union.....without the slightest dependence on foreign countries....."

"An important role in the development of Soviet aerial surveying has been played by M. M. Businov, who designed a series of excellent, wide-angle lenses with focal lengths of 100mm. and 70mm. The 100mm. objective was made in the U.S.S.R. three years before a similar objective was manufactured abroad. The 70-millimeter focal length objective, using 18 x 18 cm. film and prints, exists only in the Soviet Union"....

T. P. Kravets, in his review entitled, "Thirty Years of Soviet Optics",⁽³⁾ says:

"In thirty years the aspect of the Soviet optical industry has changed beyond recognition. Before 1920, not one kilogram of optical glass was produced in our country. Now all demands of industry for this basic material are satisfied by domestic production. Importation of optical glass ceased in 1925. All needs of our artillery, aviation and navy for optical instruments such as binoculars, range-finders, periscopes, aerial photographic cameras, and aerial photo objectives are satisfied by our own plants. They are made by Soviet engineers and workers, designed by Soviet scientists, put into production by Soviet technicians and made from Soviet materials at Soviet plants"....

We should note here that all three Soviet authors quoted above are well-known in optical research and are not irresponsible politicians. Even allowing for the fact that some glorification of Soviet achievements is expected of every Soviet author, the contrast between conditions of Tsarist

Approved For Release 1999/09/02 : CIA-RDP79-01083A000100050001-3

3
SECRET

SECRET

Approved For Release 1999/09/02 : CIA-RDP79-01083A000100050001-3
times and those of the present, is still notable enough to permit an old man
like Professor Kravets to make such a positive statement.

In order to verify these Soviet claims we must next investigate the fol-
lowing components of the Soviet optical industry:

- (1) Training of personnel
- (2) Centers of research
- (3) Production of optical glass
- (4) Factories of geodetic and photogrammetric instruments

1. TRAINING CENTERS IN OPTICS

a. Universities

Of the 32 universities in the U.S.S.R. in 1950, ⁽⁴⁾ the following
thirteen had specializations in optics:

Azerbaydzhanskiy (in Baku)
Vil'nyuskiy
Dnepropetrovskiy
Yerevanskiy
Irkutskiy
Kazanskiy
Kazakhskiy
Kiyevskiy
Latviyskiy (in Riga)
Odeskiy
Saratovskiy
Tomskiy
Uzbeyskiy (in Samarkand)

In addition to these, Leningrad University specialized in the Theory
of Astronomical Instruments.

It is difficult to ascertain just what is meant by "specialization" in
U.S.S.R. universities. The term means more than one or two courses in the
subject and some kind of specialists are supposed to be the final product of
such training. Presumably this training deals with the theory of optics
rather than in the construction of instruments.

SECRET

Approved For Release 1999/09/02 : CIA-RDP79-01083A000100050001-3

b. Institutes

There are, however, several institutes in which the training of students is definitely in the field of construction of instruments. Among these are:

Leningradskiy Institut Tochnoy Mekhaniki i Optiki (Leningrad Institute of Precision Mechanics and Optics), Leningrad, Demidov Per. No. 10. This Institute has five faculties (departments) of which the following should be noted: precision mechanics, specializing in gyroscopic, navigational and time instruments; optical mechanics, specializing in geodetic and optical instruments for precision measurements.

Although the primary task assigned to this Institute is the training of engineers in precision mechanics and optics, considerable research is carried on and at least two serials are published there, ("Trudy" (Transactions) and "Theory and Design of Optical-Mechanical Instruments") in addition to many monographs. Its staff includes one of the better-known designers of optical instruments, V. N. Churilovskiy.

Moskovskiy Stankoinstrumental'nyy Institut (Moscow Machine Tool and Instrumentation Institute), Moscow, Per. No. 3-a. This Institute has as one of its specialities the construction of optical instruments for precision instruments.

Moskovskoye Vyssheye Tekhnicheskoye Uchilische (Moscow Higher Technical School). Moscow, 2-aya Baumanskaya, No. 5. This is one of the older schools, well-known for its excellency, which has a department of instrumentation, with one of its specialities being optical and mechanical instruments for precise measurements.

Approved For Release 1999/09/02 : CIA-RDP79-01083A000100050001-3

SECRET

SECRET

~~Moskovskiy Institut Inzhenerov 999/09/02 : CIA-RDP79-01083A000100050001-3~~
~~Approved For Release 1999/09/02 : CIA-RDP79-01083A000100050001-3~~

(Moscow Institute of Engineers of Geodesy, Aerial Surveying and Cartography) Moscow, Gorokhovskiy, per. No. 4. In this Institute there is a department of Optics and Mechanics, which specializes in geodetic instrumentation.

There are no data available concerning the number of graduates from these centers of training. It is not unreasonable, however, to assume that at least five students per year are graduated each year, either from Universities (theoretical training) or from technical schools (production training). Even such a low figure would result in an annual output of approximately 90 trained personnel in optics. This output, repeated over a period of thirty years would result in hundreds of educated and experienced people in the U.S.S.R. who could be considered as experts in the various field of optics.

Some verification of this estimate may be found in the number of copies printed for each of the treatises issued in applied optics published in the Soviet Union. One of these by Professor D. S. Volosov, "Methods of Design of Complex Photographic Systems", 1948, ⁽⁵⁾ is held in high esteem by specialists in optics in the United States. A thorough knowledge of geometrical optics, considerably beyond the knowledge of the average university student in this country, is required to completely comprehend this book. Nevertheless, it was published in an edition of 5000 copies.

Another book on the same subject by A. I. Tudorovskiy, "Theory of Optical Instruments", Part I, 1948 and Part II, 1952, ⁽⁶⁾ a veritable encyclopedia of optical design, (1228 pages) was published in 3000 copies.

Apparently there is no question but that the Soviets have at their disposal at the present time a very large corps of people skilled in the problems of applied optics.

Approved For Release 1999/09/02 : CIA-RDP79-01083A000100050001-3

SECRET

SECRET

~~Approved For Release~~ 1999/09/02 : CIA-RDP79-01083A000100050001-3

Some research in optical instrumentation is done at all teaching centers described above. However, there are several centers which specialize in optical research only, of which the most important is Gosudarstvennyy Opticheskiy Institut (GOI), (State Optical Institute), Leningrad, Vas. Ostrov, Birzhevaya Liniya, No. 12-14, which was founded in 1918. A detailed account of the activities of this Institute is available for the period of its existence until 1935, ⁽⁷⁾ but very little detailed information is available for the period after that time. In 1935 it had no fewer than 264 scientific workers on its staff, including such outstanding figures in the development of the Soviet optical industry as

- S. I. Vavilov (died in 1951)
- D. S. Volosov
- D. D. Maksutov
- G. G. Slyusarev
- A. I. Tudorovskiy
- I. V. Grebenshchikov

The role of Vavilov was especially important since he was also the president of the Academy of Sciences of the U.S.S.R. at the time. The activity of the Institute includes all aspects of applied optics and is closely coordinated with the needs of military establishments. ⁽⁸⁾

Tsentral'nyy N.-I. Institut Geodezii Aeros'nyenki i Kartografii (Central Scientific Research Institute of Geodesy, Aerial Surveying and Cartography), Moscow. (TsNIIGAIK). Research in optics in this Institute is directed toward the development of geodetic and aerial surveying instruments. The most important personalities here are

- M. M. Rusinov
- F. V. Drobyshhev
- M. D. Konshin

Approved For Release 1999/09/02 : CIA-RDP79-01083A000100050001-3

SECRET

SECRET

Approved For Release 1999/09/02 : CIA-RDP79-01083A000100050001-3
but a number of other designers are mentioned from time to time in the literature, such as N. V. Viktorov, D. I. Aronov and A. Sh. Shakhverdov.

There are numerous other centers of research in which the problems of optical glass and instrument design are treated. One such center is the Institut Khimii Silikatov (Institute of the Chemistry of Silicates), Academy of Sciences of the U.S.S.R., where Professor I. V. Grebenshchikov (also connected with GOI) has been working since 1944 on the physical-chemical properties and synthesis of transparent plastics for purposes of applied optics.⁽⁹⁾ The development of optical glass also seems to be one of the responsibilities of the Vsesoyuz. Nauchno-Issled. Institut Stekla (All-Union Scientific Research Institute of Glass, VNIIS). One of the staff of this Institute, mentioned in a recent publication,⁽¹⁰⁾ M. A. Tsaritsyn, is also connected in some way with GOI and is known as a designer of optical apparatus. In the Vses. N.-I. Instrumental'nyy Institut (All-Union Scientific Research Institute of Instrumentation), the general problem of instrumentation is pursued.

The most conspicuous gap in our information with regard to both training and research is the activity of a number of secret institutes in which work in optics, probably, and in radio methods of surveying is certainly being carried on.

3. PRODUCTION OF OPTICAL GLASS

A list of 73 kinds of optical glass manufactured in the U.S.S.R. is given in a source printed in 1948⁽⁶⁾ and repeated without changes in a 1951 source⁽¹¹⁾. The following table gives a summary of the optical glass availability in the U.S.S.R., according to these sources:

Kind	Designation	Number of kinds
Crown	K	11
Barium-Crown	BK	10
Crown-Flint	KF	3
Barium-Flint	BF	16
Light Flint	LF	7
Heavy Crown	TK	11
Flint	F	5
Heavy Flint	TF	6
Special	O	4

This, of course, is not a complete list of optical glasses manufactured in the U.S.S.R. In another source dated 1951⁽²⁾ three kinds of optical glass not given in the above table are included and Volosov,⁽⁵⁾ in 1948 refers to experimentation with new lanthanum and thallium glasses. A claim is made by D. D. Maksutov, one of the best known designers of astronomical instruments, that the Soviet ultra-violet glasses, K-8, F-1 and TF-1, surpass in quality any ultra violet glass of foreign manufacture.⁽¹²⁾

There are several plants in the U.S.S.R. manufacturing optical glass. There is an experimental plant attached to the Optical Institute, but this cannot be considered as producing glass for industry.

a. Manufacturing Plants

The plants, LENZOS, (Leningradskiy Zavod Opticheskogo Stekla: Leningrad Factory of Optical Glass), and IZOS (Izyumskiy Zavod Opticheskogo Stekla: Izyum Factory of Optical Glass, in Izyum, Ukraine) devote their entire

SECRET

Approved For Release 1999/09/02 : CIA-RDP79-01083A000100050001-3
facilities to the manufacture of optical glass

In regard to metals, alloys and plastics the Russians apparently have no lack in facilities or technology. There are dozens of research institutes in these branches of industry and constant experimentation with alloys and plastics is going on. In this connection one plant is frequently mentioned in the literature. This is "Elekrostal" located in Noginsk (Moskva Rayon). It produces what might be called precision alloys for various purposes of instrumentation. Drobyashev⁽²⁾ gives a list of 23 alloys and six types of plastics used in photogrammetric instrumentation. Ball-bearings, micrometric screws, supports, cams, etc., all of which are manufactured in Russia, are described.

Such auxiliary apparatus as special lamps for instruments, levels, microscopes, etc., are all manufactured in the U.S.S.R. In short, one gets an impression of complete independence of Russian designers of geodetic and photogrammetric instruments of the outside world. At least such a claim is made very emphatically by Soviet authors.

4. FACTORIES OF GEODETIC AND PHOTOGRAMMETRIC INSTRUMENTS

There are a dozen or more factories in the U.S.S.R. manufacturing various types of optical instruments. Specifically, geodetic and photogrammetric instruments are manufactured at three plants: Aerogeobribor, Geodeziya and Geofizika, all in Moscow. The first two are mentioned in a recent article on geodetic instruments in the Soviet Encyclopedia of 1951. However, a 1949 catalogue of geodetic instruments⁽¹⁵⁾ names none of these factories. Instead, we find a whole series of new factories manufacturing the same geodetic instruments. There seems to be no doubt that here is an example of duplication of name, the historic name and the name of the ministry to which it is attached.

Approved For Release 1999/09/02 : CIA-RDP79-01083A000100050001-3

SECRET

SECRET

Approved For Release 1999/09/02 : CIA-RDP79-01083A000100050001-3

It is even possible that these same factories may have identifying numbers also. It is impossible to identify each factory positively but with some reservation the following tentative scheme has been worked out:

Aerogeobribor: Zavod GUGK

Geodeziya: Zavod Ministerstva Vooruzheniya SSSR.

Geofizika: Zavod Ministerstva Geologii

It is to be noted that the names of Ministerstvo Vooruzheniya (Ministry of Rearmament) and of Geology were abolished in the reorganization of March 15, 1953, so that further changes in these names should be expected.

(1) "Aerogeopribor" (the name is a combination of three Russian words which mean aerial geodetic instruments).

A detailed description⁽¹⁶⁾ of this plant as of 1939 is available. It was an outgrowth of a repair shop at the Main Directorate of Geodesy and Cartography. It began actual operations as a factory in 1933. As is typical of Russian reports the author deals with percentages rather than with absolute figures. Thus, the number of workers in 1939 was 15 times the number of workers in 1929, but this latter figure is not given. It is known that in 1937 there were 600 workers at this factory⁽¹⁷⁾, and in 1936 there were 122 people counted as technicians and engineers⁽¹⁸⁾. The present contingent is undoubtedly much larger.

In 1937 the program of construction called for:

125 precision theodolites

25 5" universals

4 10" universals

Approved For Release 1999/09/02 : CIA-RDP79-01083A000100050001-3

SECRET

Approved For Release 1999/09/02 : CIA-RDP79-01083A000100050001-3
By 1939 instruments bearing numbers in the 3,000's were issued, and in

1940, instrument No. 5205 was mentioned. The factory was evidently developing very rapidly. It is undoubtedly the main factory for the production of geodetic instruments.

(2) "Geodeziya" (Geodesy). Moscow, Zatsupa, Malaya Pimenskaya No. 14. This factory, established in 1923, was a development of the geodetic shop of the Corps of Military Engineers (Leningrad). The first instruments were manufactured in 1923. By 1928 it had produced over 3,000 various instruments, apparently all of small size, such as levels, theodolites, etc.⁽¹³⁾. In 1927 it had about 300 qualified workers on its staff.

(3) "Geofizika" (Geophysics). Moscow, Sokol'niki, Stromynka No. 24. This factory was organized somewhat later than 1923 (no precise statement to this effect has been found). First instruments were manufactured in 1927. This factory is a development of the small Pre-Revolutionary factory of Schwabe and Tryndin (Moscow).

(4) Zavod Ministerstva Geologii (Factory of the Ministry of Geology): This is a typical example of a factory attached to a ministry or directorate and which manufactures apparatus for the needs of that ministry. It is known that some gravimetric apparatus is constructed at this plant.⁽²⁰⁾

(5) Zavod Ministerstva Vooruzhennykh Sil (Factory of the Ministry of Armed Forces): this factory is constructing static gravimeters for the detailed investigation of the gravimetric field of the U.S.S.R.

(6) Zavod Ministerstva Vooruzheniya (Factory of the Ministry of Rearma-ment). As previously mentioned, this is probably another name for the factory, "Geodeziya". A recent source⁽¹⁵⁾ contains a description of a number of geodetic and photogrammetric instruments, such as optical theodolites, phototransformers

Approved For Release 1999/09/02 : CIA-RDP79-01083A000100050001-3

SECRET

SECRET

Approved For Release 1999/09/02 : CIA-RDP79-01083A000100050001-3
and stereocomparators, which are produced here.

(7) Zavod G.U.G.K. (Factory of Main Directorate of Geodesy and Cartography).

In all probability this is the same as the factory, "Aerogeopribor". The same source⁽¹⁵⁾ of 1949 lists a number of instruments manufactured at this factory, such as stereoscopes, astronomic universals, etc.

(8) Laboratoriya G.U.G.K. (Laboratory of the Main Directorate of Geodesy and Cartography) manufactures the Soviet multiplex and aerial cameras of the Russar type. (Russar-29 is described in Source 15).

In addition to these factories, there are a number of shops and smaller factories attached to various institutes, ministries, directorates, etc., where some geodetic instruments are being manufactured. Sources (15) and (20) indicate no fewer than eleven such establishments.

Of especial interest are two factories not mentioned in open sources. Information concerning them has been obtained from German technicians employed by the Soviets after the war. They are:

(9) Kiyev Arsenal where main production is of ordinary photographic cameras, but some simple geodetic instruments are known to be manufactured.⁽²¹⁾

(10) Zavod 393 (Factory No. 393 in Krasnogorsk, Moscow Region) which appears to be something like the Soviet section of Zeiss⁽²²⁾.

The above-named factories, (1) to (7), do not appear to manufacture all of their own optical parts, such as lenses, mirrors, prisms, etc., but depend in some measure on other factories where such parts are produced. Among such factories the following are known; (7, 13) GOMZ (Abbreviation for State Optical-Mechanical Plant, Leningrad, Vyborgskaya Strona, Chugunnaya Ul. No. 2a), LOMZ (Abbreviation for Leningrad Optical-Mechanical Plant), and Zavod No. 19 (Plant No. 19).

SECRET

In Approved For Release 1999/09/02 : CIA-RDP79-01083A000100050001-3

of our study we must look at it from the historical point of view. The Russians are proud of their optical industry because their older scientists remember the time when the simplest apparatus had to be imported from abroad. Their claim that "they are now completely independent of the West in regard to optical industry" should be accepted in this sense; they can manufacture any instrument that is necessary for the satisfactory solution of their current problems in aerial surveying and geodesy but not in sufficient quantity to satisfy their needs. Perhaps their instruments are not as good as those of the West, but for the time being they are adequate.

There are two arguments against this point of view. First, it is known that German optical workers (especially from the Zeiss factory) were transferred to the U.S.S.R. in large numbers. (Plant No. 393). The second is the extreme avidity with which the Russians pick up any bit of information about technological developments in the West. These two facts seem to contradict very definitely the Soviet claim of independence of their technology.

It seems to us that neither of these arguments is decisive. In spite of their dogmatism the Russians are eminently practical people. They had every reason to respect German technology and would not pass up a chance to learn something directly from the Germans. No matter how good Soviet instruments are, the reputation of the Zeiss factory in optics is so high that any optical man would be interested in getting first-hand information about this factory. Moreover, exploitation of German technology is by no means restricted to the U.S.S.R. It is only the scope and ruthlessness of Russian exploitation that is remarkable. The setting up of the Zeiss factory in the U.S.S.R. indicates their desire to speed up the improvement of their optical industry in the interest of military requirements.

Approved For Release 1999/09/02 : CIA-RDP79-01083A000100050001-3

SECRET

SECRET

Approved For Release 1999/09/02 : CIA-RDP79-01083A000100050001-3
The other argument seems to be more significant. Soviet writers show

excellent acquaintance with scientific and technological progress of the West. They have an efficient system of information whereby all papers published in the West are brought to the attention of Soviet scientific workers and engineers. They appear to be taking all measures not to allow any new scientific idea or invention made in the West to pass unnoticed. This attitude is quite clear in all Soviet scientific and technical literature and is confirmed by the recent experience of German engineers working in the U.S.S.R.⁽²³⁾ Again, interpretation of this attitude should not be attempted without very thorough study of Soviet social and political conditions. This reaching for knowledge may mean several things, such as that

(a) The Russians have no originality, and are forever doomed to trail behind the Western nations in their scientific and technological development. That is, in this respect the whole Soviet complex is considered to be more like Japan, than Germany.

(b) The social, cultural and political background of the U.S.S.R. is such as to prevent originality.

(c) Scientific and technological development in the U.S.S.R. is still in an imitative stage. With further progress of science and technology, Soviet originality will assert itself.

A Soviet writer would subscribe to explanation (c) maintaining publically that the state of originality has already been reached. In private conversation he would probably admit that it is "Not quite so yet, but it will be so, and very soon."

After much deliberation we also accept tentatively the possibility (c) in spite of the fact that no satisfactory explanation can be offered to account

Approved For Release 1999/09/02 : CIA-RDP79-01083A000100050001-3

SECRET

SECRET

Approved For Release 1999/09/02 : CIA-RDP79-01083A000100050001-3

for the appearance of original, or nearly original, thinkers in science and technology in the atmosphere of political and cultural pressure. The Soviet scientific man somehow develops originality despite the rigid dogma to which he must adhere. In our own field, the work of Grebenshchikov in coating the surfaces of lenses, of Rusinov in the design of cameras and of Mandel'shtam and Papaleksi in radiolocation are sufficient proofs of incipient originality. All these developments are said to have occurred years before similar developments in the West, a claim that is very difficult to either substantiate or reject. Nevertheless, it is fairly clear that in these cases there was no direct copying of Western inventions.

We conclude, then, that the U.S.S.R. optical industry (in the scope of our interest) has the necessary scientific personnel and sufficient industrial base to become one of the best industries in the world. This is merely an appraisal of potentiality, not a prophecy. There are other factors which may not allow this industry to develop to its fullest extent. Such are, for instance:

(a) Lack of intermediate personnel, highly skilled workers, foremen, technicians, etc. The Soviets are conscious of this difficulty and have taken drastic steps to obviate it, but even in 1952 the situation was bad in this respect according to German reports.

(b) The political system in which a competent director of a factory can be dismissed and replaced by a technically ignorant party man.

(c) The possibility of a general purge such as occurred in the years between 1935-37 when much talent and experience was lost to the Soviets.

Approved For Release 1999/09/02 : CIA-RDP79-01083A000100050001-3

SECRET

SECRET

Approved For Release 1999/09/02 : CIA-RDP79-01083A000100050001-3

B. LIMITATIONS OF PRESENT STUDY

The limitations of any attempt to appraise the Russian scientific situation must be clearly understood lest we make very erroneous conclusions from the available sources of information. The sources of the difficulties of research on the U.S.S.R. not sufficiently appreciated by many people dealing with this problem, can be stated this way:

(1) Extreme fluidity of the situation. This fact becomes very obvious to anyone who has tried to follow the history of any particular research institute. Several institutes merge into one, others split into several independent institutes, still others simply change their names, and there is a constant reshuffling of these institutes among ministries, bureaus, directorates, etc. The general trend is toward multiplication and fractionalization of effort, and some recent Russian sources assert that there are now 3,500 such institutions. This figure is likely to be taken as an example of Russian exaggeration but we consider it credible if it refers to research units rather than to organizations known as Research Institutes. There are some 1,000 institutions which may be properly referred to as research institutes, and there is an undetermined number of secret research institutes. (No. 627 has been encountered) In addition, all large industrial plants have laboratories associated with them, and in some cases a whole network of laboratories is attached to a plant and employs hundreds of research scientists and engineers. Further, innumerable government bureaus, directorates, trusts, etc., have some sort of research unit attached to them. Soviet sources have stated that since the war the number of research organizations has increased by 50 percent, and the number of scientists engaged by them by 100 percent.

Approved For Release 1999/09/02 : CIA-RDP79-01083A000100050001-3

SECRET

SECRET

Approved For Release 1999/09/02 : CIA-RDP79-01083A000100050001-3
To keep track of all these changes requires so much time and labor that

any particular research group in this country is always in danger of using obsolete information.

(2) Extreme secrecy of operation. In reading Russian literature since 1950 one is impressed with the obscure language used, language that probably can be understood by a few initiated people and which is becoming the most striking characteristic of Russian periodicals. If we take, for instance, such a seemingly innocuous subject as fuel, we find in recent numbers of the periodical, "Za Ekonomiyu Topliva," (Fuel Economy) factories named only by abbreviations (such as GAZ, ZIS, etc.), by numbers, by letters of the alphabet (like factory N), or finally by the name of its director ("factory the director of which is comrade Ivanov!"). Such books as Armand's Research Institutes of Heavy Industry, ⁽⁷⁾ where each institute is described in full detail are no longer allowed to leave the U.S.S.R.

In a recent volume devoted to the recipients of Stalin prizes in 1950 the not unusual entry is: person so and so, a member of a research institute, awarded the prize for the development of a new instrument. Only by painstaking research and collection of other information on this person is it possible to arrive at an intelligent guess ~~as to what~~ that instrument or institute might be.

At the same time, the constant complaint of Russian authors is that the West does not appreciate the scientific and technological development in the U.S.S.R. (conspiracy of silence, etc.)

It seems to us that the only safe principle in dealing with Russian material from open sources is this: what we derive from the study of these sources is the minimum of Russian technological development. The most important discoveries and inventions are kept secret. If these discoveries are made independently

Approved For Release 1999/09/02 : CIA-RDP79-01083A000100050001-3

SECRET

SECRET

Approved For Release 1999/09/02 : CIA-RDP79-01083A000100050001-3
In the West, we shall hear of Russian claims of priority. Surprises in this respect are not only possible but absolutely inevitable.

(3) Lack of Knowledge. The rapidly changing situation in the U.S.S.R. and the secrecy surrounding the Soviet scientific and technological development make it extremely difficult even for a person who is well versed in the language to find the material necessary to form a balanced judgment about Soviet capabilities. The entire apparatus such as this country had in regard to knowledge of German capabilities is missing. In 1940, on every university campus in the U.S.A. one could find scientists who had personal acquaintance with their opposite members in Germany, who followed German developments in their own fields of interest from year to year and who had no necessity for interpreters.

Most Western scientists are incredibly poorly informed about the U.S.S.R. Even in the days when Russian scientific papers were published, either wholly or abstracted in one of the Western languages, Russian scientific discoveries were largely overlooked by the West. Some well authenticated examples can be quoted, and there is usually a grain of truth in the Soviet extravagant claims of priority. To Western scientists, Russian and Soviet science has always been a terra incognita.

Two examples illustrating this in our own fields are of interest. In a review of lenses used for aerial photography by R. Kingslake (1942 and 1947) not one word about Soviet lenses can be found (24). In an article by J. C. Gardner and F. E. Washer, 1948, which dealt with wide-angle, aerial photographic lenses specifically, (25) the only mention of Soviet work is restricted to a quotation from a note by G. Slyusarev in the same American periodical (26), and

Approved For Release 1999/09/02 : CIA-RDP79-01083A000100050001-3

SECRET

SECRET

Approved For Release 1999/09/02 : CIA-RDP79-01083A000100050001-3
that on only one problem of geometrical optics. The authors were evidently

unaware that Slyusarev was one of the foremost Soviet designer of lenses.

One might think that the Germans would be better informed than this but such is not the case. In a recent review, ⁽²⁷⁾ by K. Schwidofsky (1950) Soviet lenses, Russar, Liar and Keonar are mentioned indeed but the information was derived from the Soviet periodical, "Geodezist", of 1938 and it states that "nothing is known about the performance of these lenses." No Soviet lenses are described in the Zeiss Index of Photographic Lenses ⁽²⁸⁾.

In a situation like this there is simply no foundation to build upon, and every elementary fact about Soviet organization, personnel, methods, etc. has to be established before an attempt of analysis can be made.

(4) Fragmentary Information. In any effort to unravel the U.S.S.R. situation one is faced with incomplete information even if the Soviets are willing to let this information out of their country. They publish so much and on so many subjects that even with the most efficient system of scanning one is likely to miss a few important items now and then. The strongest factual part of this report is the analysis of Russian photogrammetric instruments. Two books, both printed in 1951, by Drobyshev ⁽²⁾ and Skiridov ⁽²⁹⁾ which we obtained in June of 1952 are excellent for this purpose. If we had had these books a year before we would have been spared the immense work of collecting, translating and analysing innumerable small articles published in various Russian periodicals.

It is to be remembered that this is not a report on the Soviet optical industry in general, but only in so far as it concerns the legitimate scope of interest of the project. No attempt has been made to utilize all available

Approved For Release 1999/09/02 : CIA-RDP79-01083A000100050001-3
20

SECRET

SECRET

Approved For Release 1999/09/02 : CIA-RDP79-01083A000100050001-3

material on the Soviet optical industry. The problem had to be restricted by considerations of time and available personnel.

There are evidently many developments in this branch of Soviet industry that either have never been reported in open sources or simply missed by us. For example a source⁽¹⁾ of 1952 speaks of many dozens (or rather "many tens" in Russian) of original Soviet lenses. What does this indefinite statement mean? To a Russian speaking person it suggests something like 60 or 70, certainly not quite a hundred. In our investigation we have come across only 18 Soviet lenses that have Russian names and are presumably either wholly of Soviet design or are modifications of previously existing models. A more thorough search would undoubtedly add more items to our list.

(5) Lack of Tangible Proof. In respect to the subject of this report, instrumentation in geodesy and photogrammetry, we must depend on what the Russians say themselves about their instruments. If we had at our disposal one of their cameras for instance, a laboratory test of it would be conclusive proof of whether or not that it is really an instrument superior to anything of that sort manufactured in the U.S.A. Since this is impossible at this time, we must assume that the Russians are telling us the truth about their test of that particular camera. On the whole this seems to be a safe assumption.

It would be difficult to imagine that in a book like that of Drobyshev, published in 5,000 copies and officially adopted as a text-book for geodetic institutes, that deliberately erroneous statements concerning performance of instruments were made. Furthermore, most of Drobyshev's statements have been checked against other articles and books published in the interval between 1930 and 1950 with no evidence of falsification found.

Approved For Release 1999/09/02 : CIA-RDP79-01083A000100050001-3

SECRET

SECRET

Approved For Release 1999/09/02 : CIA-RDP79-01083A000100050001-3
The only concrete piece of evidence relating to the Soviet level in the

optical industry that has come to our attention is an analysis of the camera, Zorkiy, ⁽³⁾ believed to have been made in Kharkov in 1950. The lens is not identified, but from Soviet sources we derive the information that this was probably Industar-22. The camera was found to be a close approximation to the German Leica and compared favorably with similar cameras made in the U.S.A. and elsewhere. The resolving power of the lens was found to be exactly the same as given by us in Table 2 (Appendix 1) based on Soviet source information.

(6) Lack of Historic Perspective. In dealing with the problem of evaluation of capabilities in the U.S.S.R., we are faced with the deplorable fact that our information refers to different periods of time. Obviously, if Soviet optical equipment of 1935 is compared with American optical equipment of 1953, no useful purpose is served. However, with the increase in secrecy about all technical and scientific work in the U.S.S.R., much of our information is obsolete. Use of this information is absolutely unavoidable and necessary in order to understand developments in the U.S.S.R., but the base for extrapolation of capabilities becomes too far removed from the present to be of absolute value.

The existence of such a large research unit as the Optical Institute in Leningrad, of itself, would appear to assure the rapid development in design of optical instruments and experimentation with optical glass. However, the gap between research and production may be serious. The Soviets emphatically deny this and assert that this gap is much less serious with them than in other countries. At any rate, without a serious study of the material published by the Optical Institute and half a dozen other institutes our picture of the U.S.S.R. optical industry is inadequate.

Approved For Release 1999/09/02 : CIA-RDP79-01083A000100050001-3

SECRET

SECRET

Approved For Release 1999/09/02 : CIA-RDP79-01083A000100050001-3

In fact, the best that can be done at the present time is to present a picture, the components of which correspond to the status of the U.S.S.R. optical industry of different years with an unspecified, but we think rather large, portion remaining concealed from our view.

Approved For Release 1999/09/02 : CIA-RDP79-01083A000100050001-3

SECRET

SECRET

Approved For Release 1999/09/02 : CIA-RDP79-01083A000100050001-3

II. GENERAL CONCLUSIONS

General conclusions of this study are as follows:

(a) In a discussion of Soviet instruments of geodesy and photogrammetry one cannot say merely that this particular instrument is good or bad. Everything depends on the purpose for which the instrument was designed. Most Russian photogrammetric instruments seem to be designed for small-scale photography.

(b) Soviet instruments appear to be carefully made and, on the average, are probably on the same technical level as those made in the U.S.A. and elsewhere.

(c) Most Soviet instruments are either direct or somewhat modified copies of well known instruments by Zeiss, Wild, etc. The only truly original instruments identified so far are the Drobyshev Stereometer developed by 1945, the Popov Stroboscopic Chronoscope and the Molodenskiy Gravimeter. However, there is much evidence of Russian cleverness in changing details of instruments to increase their precision or to adjust them for specific purposes.

(d) Aerial cameras of the Russar type, if their descriptions are valid, are extremely good for small scale mapping. Every effort should be made to obtain these cameras.

(e) In regard to Russian claims of invention of so many instruments which are probably copies of Western instruments, two explanations are possible: either the Russians simply do not know of the existence of such instruments and developed them independently (which does not seem likely) or their definition of authorship is so loose that a few changes here and there in an instrument allows them to consider it as their own invention.

Approved For Release 1999/09/02 : CIA-RDP79-01083A000100050001-3

SECRET

SECRET

Approved For Release 1999/09/02 : CIA-RDP79-01083A000100050001-3

(f) The development of Russian instrumentation is proceeding along lines more or less parallel with those of other countries with a difference of emphasis necessitated by the adherence to different methods of aerial surveying and surface geodesy. Some innovations and changes in construction are definitely Soviet contributions. In at least one case it is possible to show that a clever device incorporated by Drobyshev in one of his instruments in 1941, was independently discovered by Wild Co. and used only since 1947.

(g) The idea that the Russians are cutting themselves off from the technological development of other countries and are liable to fall into a state of stagnation should be definitely rejected. There is overwhelming evidence that the Russians are well aware of their deficiencies and that they are diligently studying the technology and pure science of the West. This is clearly stated in many of the official pronouncements of their leaders and should be quite clear to anyone who has followed the Russian technical literature reaching this country.

A recent compilation⁽¹¹⁾ of Russian serials published since the war shows that 47 Soviet technical serials deal exclusively with review of foreign developments in science and technology. One of these serials is a digest of foreign patents, consisting of 42 sections and dealing with every branch of technology. There are many articles in Russian professional periodicals and many books dealing with foreign scientific developments. Almost every significant American book on science is immediately translated by the Russians and published often in a greater number of copies than the original edition in the U.S.A. Emphasis on the teaching of foreign languages, especially English, in Russian schools is strong, and the printing of English-Russian dictionaries in every branch of technology in a large number of copies indicates the real need of keeping up with the West. At least ten such dictionaries have been published

Approved For Release 1999/09/02 : CIA-RDP79-01083A000100050001-3

SECRET

SECRET

Approved For Release 1999/09/02 : CIA-RDP79-01083A000100050001-3
within the last three years. One, for example, on machinery and metal treatment, was printed in 15,000 copies.

We must assume then that the Russians are very well informed of the technological development in the West, while we have an exceedingly sketchy idea of the corresponding development in the U.S.S.R. In fact, it may be said that the Russians consider the West as some sort of gigantic laboratory working for them. They even used to publish a serial frankly called "Foreign Science in the Service of Socialist Reconstruction".

(h) There is little evidence of the nationalistic attitude toward instrumentation which would compel the Russians to use their own instruments even if they are inferior to the instruments produced in the West. In pre-war publications, tests of foreign-made instruments and their comparisons with Soviet made instruments are very thorough and quite fair. For the more recent period our information is scanty. The most recent material indicates one interesting feature: some instruments by Zeiss or Wild are described and praised, but the Soviets neglect to say that these instruments are of foreign production. On the other hand, they do not say that they were constructed in the U.S.S.R. Many instruments that the Soviets claimed as their own invention have been traced to foreign instruments somewhat modified and adapted for some particular problem.

The Russian attitude in this respect may be described as follows: they are sure they can produce just as good or even better instruments than any made in the West, and they loathe to admit that even now they are compelled to use some instruments of foreign make.

(1) The Soviet claim of their independence on the outside world in regard to geodetic, gravimetric and photogrammetric instruments is justified as to quality but probably not as to quantity. This cannot be ascribed to the fact

SECRET

Approved For Release 1999/09/02 : CIA-RDP79-01083A000100050001-3

that the Soviets captured the Zeiss factory in Jena. The noticeable development of Russian optical instrumentation is quite evident since about 1935. In other words the Soviets can manufacture satisfactory instruments for the above named purposes, but the demand for such instruments cannot be fully met by Soviet industry, and it was necessary to transfer such a factory as Zeiss to solve the problem of adequate supply.

(j) Considering the general status of Russian industry twenty years ago the development of optical instrumentation is remarkable.

(k) This rapid development of instrumentation should be ascribed to the Russian system of training, research and production, especially to the fact that research institutes and factories are under direct control of government units which are primarily using the results of research and manufactured instruments.

(l) The interval of time between the invention of a new device and its mass production is claimed by the Soviets to be much shorter in the U.S.S.R. than anywhere else in the world. These claims ought to be seriously considered. Reports of research institutes always emphasize the fact that so many of their inventions were adopted in industry. This is possible in the U.S.S.R. where they do not have to consider such problems as the infringement of patents, financial justification of a new line of instruments, or the state of the market. Undoubtedly sometimes hasty decisions can be made in this respect, but one is impressed by the thoroughness of tests to which a new model is subjected before it is adopted for mass production.

Approved For Release 1999/09/02 : CIA-RDP79-01083A000100050001-3

SECRET

SECRET

Approved For Release 1999/09/02 : CIA-RDP79-01083A000100050001-3

A. ADEQUACY OF SOURCES

Something about the availability and reliability of sources had to be said in the body of the report as well as in the appendices in order to make our representation of the situation in the U.S.S.R. logical and coherent. We can now summarize our conclusions and point out the gaps in our information in these subjects touched upon in this report.

Obviously only a small fraction of all scientific and technical material published by the Soviets is available in the West. This fraction is diminishing as the time goes on. A general statement on this subject, without a detailed study would be rash, indeed, but the situation in respect to geodetic and cartographic publications is very definite. If we take as an example, for instance, the most important geodetic publication, Trudy TsNIIGAIK, of the 86 volumes published in the period 1931-1952 we have found with the most intensive search in this country and abroad, only 40 volumes; that is, about 44 percent. Moreover, most of the available volumes were published before and during the war. If we separate the coverage into the periods, 1931-1945 and 1946-1952 we have the following data:

Coverage 1931-1945	35 volumes out of 47	75 percent
Coverage 1946-1952	5 volumes out of 35	15 percent

This situation is typical with all Russian material examined in connection with our project including such associated topics as physics, geophysics, etc.

It should be remembered that the situation described above applies to publications, which from the Soviet point of view are not secret. They are openly quoted in literature and for most of the missing volumes, complete

28
Approved For Release 1999/09/02 : CIA-RDP79-01083A000100050001-3

SECRET

SECRET

Approved For Release 1999/09/02 : CIA-RDP79-01083A000100050001-3
tables of contents are known. There can be little doubt that the most significant developments in science and technology in the U.S.S.R. never get into print.

The next question is, then, whether the estimated 15 percent of Russian technical literature in our field is representative of the whole or there are some items that are deliberately withheld from circulation abroad? Analysis of the subject content of the missing volumes indicates that the latter is a definite possibility since the withheld volumes, generally deal with some phase of the application of gravimetry to geodetic problems.

The situation in respect to coverage of instrumentation in this report can be summarized as follows:

- I. Instruments for photogrammetry: Coverage is considered satisfactory and up to date, due mostly to recent sources (2) and (29).
- II. Geodetic instruments: Coverage satisfactory up to about 1945. Many instruments are mentioned after 1945, but are very sketchily described.
- III. Gravimetry apparatus: Coverage satisfactory and up-to-date due mostly to recent sources (47) and (48).
- IV. Photographic cameras: Coverage fairly satisfactory but only up to about 1947. There may be significant developments in recent years.
- V. Radio apparatus: Coverage most unsatisfactory. Description of instruments stops in 1939 and obviously the present status of radio instrumentation bears little resemblance to the situation of 1939.
- VI. Astronomic instruments: Coverage satisfactory up to about 1950.

SECRET

Approved For Release 1999/09/02 : CIA-RDP79-01083A000100050001-3

B. SOURCES EXAMINED

1. Mikhaylov, V. Ya.: Fotografiya i Aerofotografiya, Moscow 1952, Geodezizdat.
2. Drobyshev, F. V.: Fotogrammetricheskiye Pribory i Instrumentovedeniye, Moscow, 1951.
3. Kravets, T. P.: Tridtsat' Let Sovetskoy Optiki, Uspekhi Fizicheskikh Nauk, Vol. 32, Vyp. 1, 1947.
4. Spravochnik dlya Postupayushchikh v Vysshiye Uchebnyye Zavedeniya Soyuz SSSR v 1950 g. - Min. Vyssh. Obraz. SSSR, 1950.
5. Volosov, D. S.: Metody Rascheta Slozhnykh Fotograficheskikh Sistem, Gos. Izd. Tekhn.-Teoret. Lit., Moscow, 1948, pp. 395.
6. Tudorovskiy, A. I.: Teoriya Opticheskikh Priborov. Akad. Nauk SSSR, Part I, 1948, pp. 661; Part II, 1952, pp. 567.
7. Armand, A. A.: Nauchno-Issledovatel'skiye Instituty Tyazheloy Promyshlennosti, 1935.
8. The State Optical Institute (G.O.I.), Leningrad, D.S.I. Report No. 50, 1952. Secret. Unfortunately this report is almost wholly on personalities rather than on the organization of work at the institute.
9. Grebenshchikov, Il'ya Vasil'yevich, article in Bol. Sov. Entsikl., Vol. 12, 1952, p. 478.
10. Kitaygorodskiy, I. I.: Steklo i Steklovareniye, Gos. Izd. Lit. Stroit. Mat., Moscow, 1950.
11. Mikhaylov, A. A., ed., "Kurs Astrofiziki i Zvezdnoy Astronomii," Vol. 1, 1951.
12. Maksutov, D. D.: Izgotovleniye i Issledovaniye Astronomicheskoy Optiki, Gos. Izd. Tekhn.-Teoret. Lit., Moscow, 1948, pp. 279.
13. Mashinostroitel'naya Promyshlennost' SSSR, Spravochnik, Vol. 1, 1933, p. 71.
14. Bukharin, N. I., ed., Nauchno-Tekhnicheskoye Obsluzhivaniye Tyazheloy Promyshlennosti, 1934.
15. Zakharova, E. I. and Lyutikov, A. P., ed., Katalog-Spravochnik Laboratornykh Priborov i Oborudovaniya, No. 34, 1949, Mashgiz.
16. Semin, I. M.: XX-Let Sovetskoy Geodezii i Kartografii, 1939.
17. Geodezist, 1937, No. 5, p. 4.
18. Geodezist, 1936, No. 10, p. 9.

Approved For Release 1999/09/02 : CIA-RDP79-01083A000100050001-3

SECRET

SECRET

Approved For Release 1999/09/02 : CIA-RDP79-01083A000100050001-3
Sbornik NTFS, Vyp. 20, 1948.

20. Zakharova, E. I. and Lyutikov, A. F., ed., Katalog-Spravochnik Laboratornykh Priborov i Oborudovaniya, No. 36, 1948.

25X1A2g

21. Central Intelligence Agency, Information Reports, Secret

25X1A2g

22. [REDACTED] Central Intelligence Agency, Information Reports.

25X1A2g

25X1A2g

23. Central Intelligence Agency, Series Information Reports, Secret.

24. Kingslake, R.: Lenses for Aerial Photography, Journ. Optical Society of Amer., Vol. 32, 1942, p. 129.

Recent Development in Lenses for Aerial Photography, Ibid., Vol. 37, 1947, p. 1.

25. Gardner, J. C. and Washer, F. E.: Lenses of Extremely Wide Angle for Airplane Mapping, Journ. Optical Society of America, Vol. 38, 1948, p. 421.

26. Slyusarev, G., Journ. Optical Society of America, Vol. 36, 1946, p. 707.

27. Schwidofsky, K.: Die Entwicklung der photogrammetrischen Instrumente, Allgemeine Vermessungs-Nachrichten 1950, No. 12.

28. Zeiss Index of Photographic Lenses, W. W. Merte, ATI No. 38399, September 1950.

29. Skiridov, A. S.: Stereofotogrammetriya, 1951.

30. Detailed Examination of Zorkiy Camera, Central Intelligence Agency, Information Report OO-T-00072 of Dec. 27, 1951. Secret.

31. Library of Congress, Serial Publications of the Soviet Union 1939-1951. A Preliminary Check List.

32. Veselovskiy, N. N.: Fotogrammetriya, 1945.

SECRET

33. Konshin, M. D. and others, Chapter 4 of "Geodeziya," Vol. 4, 1948.
Approved For Release 1999/09/02 : CIA-RDP79-01083A000100050001-3
Kel', N. and others, Chapter 4 of "Geodeziya," Vol. 4, 1940.
34. Yeliseyev, S. V.: Geodezicheskoye Priborostroyeniye v SSSR, Sbornik NTIPS, Vyp. 20, 1948, p. 71.
35. Begunov, B. W.: Optika Geodezicheskikh Instrumentov Zavoda "Aerogeopribor", Geodezist, 1937, No. 6, p. 40 and No. 7, p. 38.
36. Zverev, M. S.: Universal'nyy Instrument Zavoda "Aerogeopribor" na Astronomicheskoy Rabote, Geodezist, 1937, No. 9, p. 35.
37. "Geodezist," 1937, No. 9, p. 72.
38. Larin, B.A.: O Rabotakh po Osvoyeniyu Geodezicheskikh Mernykh Priborov iz Sovetskogo Invara, Geodezist.
39. Articles "Geodeziya" and "Geodezicheskiye Instrumenty" in Bol'shaya Sovetskaya Entsiklopediya, Vol. 9, 1951.
40. Larin, B. A.: Superinvarnyye Provolki, Sbornik NTIPS, Vyp. 21, 1948, p. 42.
41. Tsvetkov, K. A.: Prakticheskaya Astronomiya, 2nd ed., 1951.
42. Geodeziya, Vol. 9, 1949, p. 377.
43. Pavlov, M. P. Tekhnika Izmereniya Skorostey i Vremeni, Mashgiz, 1950
44. Gusev, N. A.: Instrumentovedeniye. Marksheydersko-Geodezicheskiye Instrumenty, 1949.
45. Chebotarev, A. S.: "Geodeziya", Part 1, 1948, pp. 467-482.
46. Grigor'yev, S. I.: O Primenenii Ploskikh Vizirnykh Tseley, etc. Geodezist, 1940, No. 9, p. 28.
47. Sorokin, L. V. and others: Kurs Geofizicheskikh Metodov Razvedki Neftyanykh Mestorozhdeniy, 1950.
48. Sorokin, L. V.: Gravimetriya i Gravimetricheskaya Razvedka, 1951.
49. Kheyfets, M. E.: Issledovaniye Uprugikh Mayatnikov, Trudy TsNIIGAIK, Vyp. 66, 1949.
50. Grushinskiy, N. P.: Ob Ispol'zovanii Gravimetrov dlya Opredeleniya Punktov I i II Klassov, Sbornik NTIPS, Vyp. 23, 1949, pp. 16-21.
51. Debler, V. A.: Primeneniye Aerosninkov Liar-6 v Usloviyakh Masshtaba Karty 1:100,000, Geodezist, 1938, No. 5, p. 54.

SECRET

Approved For Release 1999/09/02 : CIA-RDP79-01083A000100050001-3

52. Vavilov, S. I., ed., *Optika v Vojennom Delo*, Vol. 1, 1945.
53. Safronov, L. T. and Krovyakov, V. I.: *Fotooborudovaniye Samoletov*, 1949.
54. Makarov, Yu. G. and Rozhdestvin, N. P.: *Aerofotorazvedovatel'naya Sluzhba*, 1947. Translation: F-TS-6798-RE.
55. Ask, Reynold E.: *Elements of Photogrammetric Optics, Manual of Photogrammetry*, 1952.
56. *Byull. Vs. Astronomo-Geodezicheskogo Obshchestva*, No. 4(11), 1948.
57. Mikhaylov, A. A., *Vestnik Ak. N. SSSR*, No. 3, 1953.
58. Fedorov, N. V., *Geodeziya*, 1949.
59. Bayrashevskiy, A. M.: *Sudovaya Radiotekhnika i Radionavigatsiya*, 1949.
60. Aseyev, B. P.: *Fazovyye Sootnosheniya v Radiotekhnike*, 1951.
61. Vodop'yanov, F. A.: *Radiolokatsiya*, 1945.
62. Mandel'shtam, L. I. and Papaleksi, N. D.: *Noveyshiye Issledovaniya Rasprostraneniya Radiovoln vdol' Zemnoy Poverkhnosti*, 1945.
63. Nesmeyanov, V. N. and Romanovskiy, G. V.: *Perspektivy Tekhnicheskogo Sovershenstvovaniya Aerosfery*, XX Let Sovetskoy Geodezii i Kartografii, Vol. 1, 1939, pp. 307-320.
64. Shchegolev, A. Ya., *Radionavigatsiya*, 1946, p. 81.
65. Papaleksi, N. D.: *Sobraniye Trudov*, 1948, Articles No. 21, 25, and 29, 1945-47.
66. *Issledovaniya Rasprostraneniya Radiovoln*, Sbornik 2, 1948, Academy of Sciences, SSSR.
67. Gerasimova, O. A.: *Obzor Opytov Primeneniya Radiolokatsionnykh Metodov v Oblasti Kartografo-Geodezicheskikh Rabot za Granitsey*, Sbornik NPPS, Vyp. 20, 1948.
68. Nikonov, B. V. and Nikonova, E. K., *Izvestiya Krymskoy Astrofizicheskoy Observatorii*, Vol. 9, 1952, p. 41.
69. Agafonova, L. D. and Nefed'yeva, A. I.: *Izvestiya Observatorii Engel'gardta*, No. 27, 1951.
70. Kaplan, J., *American Scientist*, Vol. 41, 1953, p. 56.
71. Ivanov-Kholednyy, G. S., *Izvestiya Krymsk. Astrofiz. Obs.*, Vol. 8, 1952, p. 115.

Approved For Release 1999/09/02 : CIA-RDP79-01083A000100050001-3

SECRET

SECRET

Approved For Release 1999/09/02 : CIA-RDP79-01083A000100050001-3

72. Mel'nikov, O. A., Izv. Glavnoy Astron. Obs. Pulkovo, Vol. 18, No. 8, 1951.
73. Badalian, G. S., Soobsh. Byurakan. Obs., No. 8, 1951.
74. Mirzoyan, L. V., Soobsh. Byurakan. Obs., No. 7, 1951.
75. Monin, G. A. and Severnyy, A. B., Izv. Krymsk. Astrofiz. Obs., Vol. 7, 1951, p. 113.
76. Stavrukhin, A., Astr. Tsirk. AK. N. SSSR, No. 121, 1951.

Approved For Release 1999/09/02 : CIA-RDP79-01083A000100050001-3

PHOTOGRAMMETRIC INSTRUMENTS

In respect to instruments used for photogrammetry we are in a rather favorable position because of the availability of two recent textbooks on this subject written by acknowledged experts in that field: Skiridov⁽²⁹⁾ and Drobyshev⁽²⁾. There are also three other important and recent sources of information: a textbook by Veselovskiy⁽³²⁾, a chapter in Vol. 9 of the Soviet encyclopedia dealing with geodesy⁽³³⁾ and a supplement to Soviet instructions for the compilation of the map on a scale of 1:100,000 which is devoted to these instruments. There are also a large number of articles in various periodicals and serials discussing particular instruments.

1. Photo Rectifiers

Drobyshev⁽²⁾ describes five photo rectifiers which are designated as follows:

Fotoreduktor of N.A. Popov
 Fotoepireduktor of F. V. Drobyshev
 Fototransformator MGI
 Malyy Fototransformator FTM
 Bol'shoy Fototransformator FTB

The first two of these instruments are merely enlarging and reducing projectors having no provision for tilt adjustment. Automatic focus is obtained, in the first instrument, by means of a rhombic inverter and in the second, by a cam and follower. Both are extremely large instruments with limited uses.

The third instrument was developed at the Moscow Institute of Engineers of Geodesy and Cartography (MGI) and is a true rectifier although with a very limited range. The adjustment of focal distances is obtained by a spiral cam

Approved For Release 1999/09/02 : CIA-RDP79-01083A000100050001-3

controlled by a foot disc. The arrangement is undoubtedly satisfactory but takes up a great deal of room.

The fourth and fifth instruments are direct copies of the Zeiss small rectifier, SEC-IV, and large rectifier, SEG-I. It is of interest to note that the Russian names Mal'yy and Bol'shoy in connection with these instruments mean simply small and large, and the Russians do not claim to have developed these instruments. On the other hand they do not say that they are merely copies of the Zeiss instruments.

Nothing comparable to the Bausch and Lomb fully automatic rectifier is described.

2. Stereocomparators*

Two stereocomparators are described by Drobyshev: 1. Horizontal'nyy Stereokomparator; 2. Naklonnyy Stereokomparator.* The first is exactly the same as the Pulfrich-Zeiss stereocomparator, which is no longer manufactured.

In the second instrument, the plane of the photographs has been tilted to make observations more convenient for a seated operator. Also, the least reading has been reduced from 0.02 to 0.01 mm.

Stereocomparators were originally developed for work with terrestrial photographs. They have never been in favor in the U.S.A. and have been largely replaced by semi-automatic plotting instruments in West European countries.

Drobyshev states that these instruments were used for terrestrial photographs during the 1904-1930-period, but since that time they have been used also for aerial photographs, which necessitated some changes. The instruments are obviously in routine use in the U.S.S.R., since they are described in their catalogue of geodetic and photogrammetric instruments for 1949⁽¹⁵⁾.

* See Figures 1, 2, and 3, pages 96, 97, 98 of Photographic Supplement, Appendix VII.

SECRET

Approved For Release 1999/09/02 : CIA-RDP79-01083A000100050001-3
At present Nistri in Italy and the Cambridge Instrument Company in England manufacture stereocomparators. The precision of measurement in each of these instruments, 0.01 mm., is the same as that claimed for the Russian device, although the system used for obtaining this precision is different in each of the three. In the Soviet instrument full length glass scales, read by means of a mechanical micrometer, are used. This method does not make allowance for the possible shrinkage of the film, as is done in the British instrument by means of a scale superimposed on the original photograph in the camera at the time of exposure.

It is stated that the collimation system of observation was applied by Drobyshev seven years before it was adopted in other countries. This is doubtful, since Pulfrich used the principle in the first Zeiss Stereocomparator built in 1901.

3. Stereopantometer of Drobyshev*

This instrument performs the same function as the Abrams Contour Finder, the Fairchild Stereocomparagraph, the Zeiss Stereotop, the Nistri Stereographometer, or any combination of mirror stereoscope and parallax bar. The Soviet and Zeiss instruments move the photographs with respect to stationary measuring marks and stereoscope; the others move the stereoscope and marks with respect to stationary photographs. So far as results are concerned, one system is as good as the other. The first results in a more compact but more complicated instrument; the second is simpler and cheaper to construct. The Soviet device introduces a luminous floating mark, probably a needless refinement in such an instrument. Nistri has an attachment for producing an orthographic projection

* See Figures 4 and 5, pages 99 and 100 of Photographic Supplement, Appendix VII.

Approved For Release 1999/09/02 : CIA-RDP79-01083A000100050001-3

SECRET

SECRET

Approved For Release 1999/09/02 : CIA-RDP79-01083A000100050001-3
at constant scale. The latest model of the Zeiss has a device for approximately
correcting the effects of small tilts.

The Russian instrument is portable and is designed for use in field work,
expeditions, etc.

4. Stereometers

The three instruments in this group represent original Soviet contributions
to the subject. No comparable instruments are manufactured in the U.S.A. or in
Western Europe, where such instruments are designed for exact determination of
elevations and for tracing contour lines on photographs and used for compilation
of maps of scales of 1:50,000 to 1:25,000. All three Soviet designs are an ex-
tension of the principle of the stereocomparator based upon two premises:

1. Both photographs will be maintained in the same plane regardless
of the tilts which may have existed at the time of exposure.
2. The line of sight of the optical viewing system will be kept
perpendicular to the plane of the photographs.

When tilted photographs are observed under these conditions, the observed
values of horizontal (x or height), parallaxes and vertical (y or orientation)
parallaxes will be in error. In order to correct these observed values the
photographs must be moved in the x direction, in the y direction, and about a
vertical axis not necessarily coinciding with the camera axis. These corrections
are applied by ingenious mechanical devices which automatically introduce the
required motions. In order to keep these devices simple, certain assumptions
are made; ie, primarily that the tilts do not exceed three degrees. The set-
tings of the correction devices are functions of the normal orientation elements.

SECRET

Approved For Release 1999/09/02 : CIA-RDP79-01083A000100050001-3
on each photograph. Apparently such an instrument has not yet been constructed. The three instruments described give only a partial solution, and further operations with the photographs are required in order to obtain complete map information from them. These instruments undoubtedly perform the function for which they were designed, but in view of the limited information obtained about them, they seem to offer no advantages over the instruments in use in the west. They are not adaptable for extension of control by bridging methods, and based on the simplicity principle, it is doubtful that a high degree of accuracy could be attained.

Topographic Stereometer of Drobyshev*

The end product of this instrument is elevations of ground points and/or contour lines drawn by hand directly upon unrectified photographs. In this respect it is roughly comparable to the Zeiss Stereotop or the Brock Stereometer, except that rectified photographs are used in the Brock instrument. All of these devices are subject to the limitation that each contour line is at a different scale.

Stereometer of Drobyshev

This instrument is a larger and more precise model of the Topographic Stereometer. It is adapted to use either glass platen illuminated from below or paper platen illuminated from above. The y parallaxes are measured and the least readings of the correction devices are smaller so that more precise values of the orientation elements are obtained. Contour lines are drawn by a pencil attached directly to the instrument rather than by hand. The precision of measurement is stated to be 0.015 mm.

* See Figures 6 and 7, pages 102 and 103 of Photographic Supplement, Appendix VII.

SECRET

SECRET

~~Kern Stereometer of Skridont~~
Approved For Release 1999/09/02 : CIA-RDP79-01083A000100050001-3

This instrument is designed solely to determine the elements of relative orientation of a stereopair by elimination of the y parallaxes at five points. Elevations or contour lines are not determined.

5. Instruments of Direct Optical Intersection

These are projection type instruments operating essentially on the same principle as the Multiplex and Kelsh plotters. Again no new principles are disclosed in Russian literature, but several interesting innovations are described. It is stated that stereoscopic vision is obtained by the use of polarized projectors and spectacles. Western experiments with this system have not been successful.

Double Projector TsNIIGA1K

This instrument was apparently designed primarily for research in various means of viewing the stereoscopic model. It offers a correct solution but has drawbacks for practical application. Variation between camera and projector focal lengths and plate sizes results in different scales for horizontal and vertical measurements. Absolute orientation is obtained by tilting the base table which could make drawing inconvenient. The two projector instruments cannot be used for bridging.

Double Projector DPD-2 of Drobyshv

The instrument is designed for producing large scale topographic maps (scale, 1:2,000 to 1:10,000) from contact diapositives. The projectors are disposed in a horizontal position and the relative orientation is performed by introducing rotations to mirrors placed in front of the objectives. A similar

* See Figures 8 and 9, pages 104 and 105 of Photographic Supplement, Appendix VII.

40
Approved For Release 1999/09/02 : CIA-RDP79-01083A000100050001-3

SECRET

SECRET

Approved For Release 1999/09/02 : CIA-RDP79-01083A000100050001-3

scheme was used in a German instrument designed by Gasser in 1915. Absolute orientation is still obtained by tilting the drawing table with respect to the fixed projectors.

The model may be viewed either by the anaglyph principle or by means of the blinking method. At present only Nistri applies the blinking method in a production instrument. Experiments have been conducted in this country but there is no unanimous preference for one method over the other.

In end product the instrument is comparable to the Kelsh plotter, but in construction and operation it is much more complicated.

Soviet Multiplex

In photogrammetric principles and operation this instrument is exactly the same as the instruments produced by Bausch and Lomb, Williamson, and others.

Optically, the ultra-wide angle coverage, 122° , and the use of aspherical condenser lenses are of great interest. A distortion-free objective of this angular coverage and the specified resolving power of 60 lines per millimeter does not exist in western instruments. To be significant this lens must be complemented with a camera objective of equal angular coverage.

6. Instruments of Optical-Mechanical Intersection

There are many different solutions possible in this category. Those selected by the Russians for development into working models are the same as those used in Western instruments. In pursuit of the national trend towards keeping the photographs co-planar, a system is described in which existing photo tilts are introduced by providing an adjustable joint in the space rods. A similar

Approved For Release 1999/09/02 : CIA-RDP79-01083A000100050001-3

SECRET

SECRET

Approved For Release 1999/09/02 : CIA-RDP79-01083A000100050001-3
system was described in Swiss patents 251686 and 262481 by H. Wild in 1948,

but no instrument using this scheme has been built.

Stereo Universal of Skiridov

This instrument, like the Kern Stereometer of the same designer, serves solely to determine the elements of relative orientation of two photographs by elimination of y parallax in five points. In this instrument the photographs are tilted, while in the stereometer instrument the parallaxes are corrected with the photographs maintained co-planar. The use made of this limited information is not described. It is probable that it is used for the settings of other instruments in which the photographs are actually plotted. Another possible use is to aid in determining the positions of nadir points and isocenters, after which the photographs may be used in radial triangulation with results equal to those obtained in space triangulation.

Radial Triangulator

The illustration, diagram of optical system, and description are precisely applicable to the Zeiss nadial triangulator.

Stereoplanigraph S P B and C-4 (Konshin)

The C-4 seems to be a description of the Zeiss Stereoplanigraph C-4, while the S P B is the Russian copy of the same instrument. The photograph of the instrument, the diagrams of the mechanical and optical systems show only minor discrepancies from the Zeiss. However, the Russian model does employ luminous measuring marks, not incorporated by Zeiss until the model C7.

Stereoscopic Universal Instrument RP-6 (Konshin)

This instrument is an attempt to reduce the complexity of the stereoplanigraph to speed up map compilation. It is not a universal instrument as the term

Approved For Release 1999/09/02 : CIA-RDP79-01083A000100050001-3

42
SECRET

SECRET

Approved For Release 1999/09/02 : CIA-RDP79-01083A000100050001-3
is understood here, since it is adaptable for use only with near vertical
aerial photographs.

In principle the instrument is a combination of a K E K Plotter and a
vertical sketchmaster. The photographs are oriented in space by means of
angular and directional motions. The elements of relative orientation obtained
in the Stereo Universal and Kern Stereometer of Skiridov are probably used
for this purpose. The mirror stereoscope allows viewing of the entire model
at once. Half silvered mirrors give the impression of the model projected upon
the drawing table. Planimetry and contours are drawn by hand on this projected
model. The instrument could not be expected to give a high order of accuracy.

Approved For Release 1999/09/02 : CIA-RDP79-01083A000100050001-3

SECRET

SECRET

Approved For Release 1999/09/02 : CIA-RDP79-01083A000100050001-3

GEODETIC INSTRUMENTS

Available information dealing with Soviet geodetic instruments is not as up-to-date as it was with respect to instruments used in photogrammetry. Detailed descriptions later than 1940 are lacking and only a few general statements about the performance of instruments have been found.

A general review of the situation as it was in 1948 is available. (34) The difficulty of construction of precise instruments requiring close co-operation of various industries is described. Soviet scientists and technicians had to start from nothing and experiment with all sorts of alloys and optical devices. It is of interest to note that, according to the author, "the development of Russian geodetic instrumentation was necessitated not only by sheer impossibility to obtain from abroad the necessary number of instruments (presumably for financial reasons) but also by the poor quality of many of these instruments". Examples given include the 2nd Universal Instruments of the German firm, "Askania", which were found to be quite unsatisfactory.

The author of this article regards the problem of construction of geodetic instruments in the U.S.S.R. as solved. Greatest difficulty was encountered with invar tapes and the problem was not yet considered as completely solved by 1948.

The optics used in geodetic instruments are described in great detail in two articles by B. N. Begunov (35), but they refer to the year, 1937. At that time no new devices were employed, but the description shows full comprehension of details.

The important point to establish is whether the Russians show the necessary critical attitude toward their instruments or whether they are dominated entirely

Approved For Release 1999/09/02 : CIA-RDP79-01083A000100050001-3

SECRET

SECRET

Approved For Release 1999/09/02 : CIA-RDP79-01083A000100050001-3

simply because it is their own. In the detailed description of instruments available for the pre-war years there is certainly no trace of exaggerated nationalism. Foreign-made and Soviet-made instruments are very thoroughly tested and appraised on the basis of their merit. The tests are so uniformly in favor of Soviet-made instruments that one might suspect that unfavorable tests are simply not reported. This, however, is only a suspicion and may perhaps be explained by the strict supervision at factories which do not release instruments unless they are really good. In the description of work of industrial establishments unsatisfactory production is often mentioned and counted as loss.

On the other hand, tests of Soviet-made instruments, when no comparison with foreign-made instruments is involved, are usually quite frank in pointing out the bad as well as good features of the instrument. As an example of this attitude we may consider the tests of the Astronomic Universal Instrument, mark AU, the first five of which were manufactured by the plant, "Aerogeopribor", in 1935. They were tested by M.S. Zverev⁽³⁶⁾, one of the foremost positional astronomers in the U.S.S.R., in his determination of astronomic co-ordinates at Laplace points in a geodetic network in the Caucasus Mountains. Points were selected near sea-level as well as at high altitudes (up to 3,100 meters). It was found that the instrument was of good stability, rotation about the vertical axis was smooth and regular, the system of illumination was excellent, and the instrument withstood the rough treatment of mountain conditions. On the other hand, this instrument which performed satisfactorily at a temperature of 15°C could not be rotated at all at a temperature of 3°C, and the micrometer showed undue sensitivity to changes in temperature. These defects were discussed with

Approved For Release 1999/09/02 : CIA-RDP79-01083A000100050001-3

SECRET

SECRET

the manufacturing plant's management which promised to correct these deficiencies in later models. The general conclusion offered here is that with necessary improvements the instrument will be quite satisfactory for astronomic determinations at points of I-order triangulation.

Such treatment of the problem certainly does not indicate any undue emotional attachment to Russian-made instruments. On the other hand, the Russians show distinct intolerance to what they consider as excessive veneration of Western technology. This attitude, so prominent at the present time, was in evidence long ago. It probably originated as soon as the Russians came to the conclusion that they could build instruments of as high quality as those made abroad.

As an illustration of this attitude we may take the controversy about geodetic instruments which appears in "Geodezist" of 1937. K. N. Smirnov, Professor of the Military-Engineering Academy, published an article very favorable to instruments manufactured by Zeiss and Wild. This article was objected to by S.V. Yeliseyev, one of the Soviet specialists in instrument construction. A rebuttal by Smirnov followed. The upshot of this controversy was something that would appear rather strange to the Western reader. The chairman of geodesy and astronomy of the Academy, Prof. N.A. Urmayev, published in the same periodical⁽³⁷⁾ an excerpt from the minutes of the meeting of the faculty in which the controversy was reviewed. It was found that Smirnov had not examined the problem with a sufficient amount of criticism. He discussed only the favorable points in the instruments of Zeiss and Wild, and not their defects, thus giving a distorted picture of instrument production abroad. Smirnov was given a warning to improve his work in a technical and "ideological-political" sense, as "required of every Soviet scientist".

SECRET

Approved For Release 1999/09/02 : CIA-RDP79-01083A000100050001-3

A. Bases Apparatus. The essential part of the Jäderin apparatus for measuring the length of geodetic bases adopted by the Russians is the 24 meter invar wire. The preparation of these wires involved considerable difficulties and up to 1937 the Soviets depended entirely on the Carpentier wires made in France.

The first attempts⁽³⁸⁾ to break this dependence on foreign industry was made in 1937 when first samples of Soviet invar metal were manufactured at the plant, "Elektrostal'", (in Noginsk, Moscow Region).

As is true of many industrial plants, "Elektrostal'" maintains its own research organization which in this case may be considered as a research institute of ferrous metallurgy. It is known that in 1934 there were no fewer than 220 people working in this institute⁽¹⁴⁾ and their number is now undoubtedly larger. Constant experimentation with all sorts of alloys is going on.

The first batch of invar wires was tested in the field in 1937 and turned out to be unsatisfactory. However, during the next year, wires of a somewhat different alloy gave a coefficient of expansion equal to 0.1×10^{-6} to 0.4×10^{-6} and their tests were considered quite satisfactory.

At the present time, the Russians consider that the problem of manufacturing invar wires has been solved completely with the production of wires of any assigned coefficient of expansion⁽³⁹⁾.

It is of interest to note that the Russians are still experimenting with this problem. They are manufacturing superinvar wires (the invar in which 5 percent of nickel is replaced by cobalt). These wires were tested⁽⁴⁰⁾ under field conditions in 1939 and 1945 and indicated a decided superiority over ordinary invar wires in at least the coefficient of expansion (which turned

Approved For Release 1999/09/02 : CIA-RDP79-01083A000100050001-3

SECRET

SECRET

Approved For Release 1999/09/02 : CIA-RDP79-01083A000100050001-3
out to be 0.26×10^{-4}). However, other properties, such as stability, are not as desirable.

B. Astronomical Instruments. For the determination of astronomic positions for I-order triangulation the Soviets, until about 1937, had depended entirely on foreign made instruments, especially those of Hildebrandt and Wild. In 1935 the plant, "Aerogeopribor", began to manufacture Astronomical Universals (AU) with the minimum scale division of 5".

Soviet astronomical instruments are described in considerable detail in a recent (1951) textbook in Practical Astronomy by K. A. Tsvetkov⁽⁴¹⁾. These instruments are designed for the determination of latitude and time with different degrees of precision depending on the order of triangulation or of astronomic determination. The statement is made that the U.S.S.R. is completely independent of foreign instrumentation but no data on the exact performance of instruments are given.

Universal instruments (that is, instruments for determination of both latitude and time) most frequently mentioned are AU 2 10, U-5 and U-10. The instrument, U-10, is described in somewhat greater detail than the others⁽⁴²⁾ and is of the less precise kind to be used for II-order triangulation and astronomic determinations in the Arctic. The task of design was to provide an instrument of minimum size and weight and suitable for Arctic conditions.

The essential novelty of this instrument is the incorporation of a totally reflecting prism at the objective end, a feature not found in any instrument made in the West. This is essentially the "broken-transit" idea, well known and extensively used everywhere but the location of the prism is most unusual. The instrument is evidently designed for observations of circum-zenith stars

Approved For Release 1999/09/02 : CIA-RDP79-01083A000100050001-3

SECRET

SECRET

Approved For Release 1999/09/02 : CIA-RDP79-01083A000100050001-3
by the Horrebow-Talcott method. The accuracy is 2".

and it is stated that estimates of one tenth of this division are easily made. Work of this instrument in the Arctic region is considered quite satisfactory.

The Soviet transit used for the most precise determination of time appears to be a very fine instrument. It is manufactured by the plant, "Aerogeopribor". The Bamberg transit is considered quite obsolete. The interesting features of the Russian instrument include the incorporation of a prism at the objective end (as in U-10) and striding level instead of a suspended level. The first feature is definitely stated to eliminate difficulties of flexure. The second improvement is of more debatable character.

There is no good description of the best Russian Universal Instrument AU 2/10 but there are several photographs of it which allow us to compare it with the best western instrument of this type, the Wild T4. Both instruments appear to be remarkably similar, the same dependence on the suspension level, the same impersonal transit micrometer, the same orthodox broken type idea (not as in Russian U-10) and apparently the same ultimate precision, perhaps somewhat in favor of the Wild instrument. Given the type of work to be performed with an instrument, it is perhaps impossible to expect any radical change in the design. A few improvements here and there are all that can be expected.

An essential part of any astronomic work is the chronometer. It was impossible to find any description of Soviet-made chronometers except for the general statement that Russian chronometers are being used and they are "not inferior in quality to those made abroad"⁽⁴¹⁾.

Many auxiliary apparatus used by the Soviets are described, but most of them are not of any great interest from the instrumental point of view. However, it might be noticed that the Russians attribute much importance to the

Approved For Release 1999/09/02 : CIA-RDP79-01083A000100050001-3

SECRET

SECRET

Approved For Release 1999/09/02 : CIA-RDP79-01083A000100050001-3
determination of the personal equation of field workers and have developed several, rather simple, apparatus for this purpose.

Constant Soviet attempts to improve the reception of time signals deserves special notice. They have developed for this purpose an apparatus called the "stroboscopic chronoscope", which appears to be unknown in the West. This apparatus is claimed to give the precision of time determination up to 0.001 second. Stroboscopic effect allows the determination of the speed of rapidly moving objects by using very short period flashes of light, and is well known in industry. Its application to astronomy was developed by P.S. Pavlov in 1937. This instrument requires considerable equipment such as highly synchronized motors and highly regulated flashes of light and is obviously not suited to field conditions. However, it is intensively used by the Russians in their time-service under laboratory conditions. The Shott pendulum clocks for the time service were duplicated by the Russians as early as 1937. In recent times much experimentation has been done to adapt quartz clocks for this purpose.

C. Surveying Instruments. The Russians are manufacturing many types of theodolites of which marks TT-2/6 and OT-02 are extensively used.

The first kind is supposed to give precision in the measurement of angles with a mean error of 0'3 to 0'7. It is a rather heavy instrument (weight 30 klg.) and it cannot be used on top of triangulation towers. For this purpose the "optical theodolite", OT-02, with a precision of 1" and TB-1 with a precision of 2", were developed. Their weight is 10 to 12 klg.

In a recent textbook by Gusev,⁽⁴⁴⁾ a statement is made that the optical theodolites TB-1 and TB-2 were developed after 1947.

Again, a comparison with theodolites of this sort made by Wild and Kern

Approved For Release 1999/09/02 : CIA-RDP79-01083A000100050001-3

50

SECRET

SECRET

Approved For Release 1999/09/02 : CIA-RDP79-01083A000100050001-3
does not indicate any essential difference between the Russian and Swiss-

made instruments. Nor do the Russians claim any particular merit of their theodolites except great rigidity and better optical system. Of particular interest in the use of graduated glass circles in theodolites of mark OT is the Soviet emphasis on weight reduction. This feature is also used in Swiss theodolites. The Russians apparently pay more attention to the practical demands of surveying than to excessive precision required for both horizontal and vertical circles. Such a notation as 2/6, refers to the smallest value of division 2" for the horizontal and 6" for the vertical circle. Unnecessary precision is always avoided to reduce costs and time of manufacturing.

The Soviets have developed the tachometer type of theodolite which they claim is much better than anything made abroad. This is the Stodolkevich automatic tachometer, described in detail in the textbook by Chebotarev⁽⁴⁵⁾. It is claimed that highly precise differences in elevation are obtained by means of this instrument automatically by means of an additional mechanical device which replaces the vertical circle. Such devices are well known in the West. The Wild Precision Telemeter DMI is designed for exactly the same purpose as the Stodolkevich adaption. The tachometer model used mostly in the U.S.S.R. is the TT50, which looks very similar to corresponding instruments of Kern and Wild.

Much the same can be said of precision levels and other auxiliary instruments.

The general conclusion is that Russian geodetic instruments are probably as good as those made in the West. The various features designed by Kern and Wild as improvements over their old work, such as internal focusing, graduated glass circles, optical micrometers, etc., are also used by the Russians, and

Approved For Release 1999/09/02 : CIA-RDP79-01083A000100050001-3

SECRET

SECRET

Approved For Release 1999/09/02 : CIA-RDP79-01083A000100050001-3

it is quite impossible to accept the CIA-RDP79-01083A000100050001-3 features from abroad or developed them independently. The Russians seem to be designing specific instruments for specific uses. They build not just a theodolite, but a theodolite to be used in the Arctic regions or at high altitudes or for mine-surveying. From the point of view of actual use, compactness and light weight may be more important considerations than is precision. Cases are mentioned where surveyors were parachuted out of planes in the remote regions of Yakutia to establish control points for aerial surveys. Under such conditions orthodox equipment is of little use.

The Russian attitude toward the west in this respect is extremely critical but not unreasonable. They give detailed tests of foreign-made theodolites and find, for instance, that the Wild Theodolite No. 159 gives a mean error in the determination of angles of 0'56, whereas the Aerogeopribor theodolite No. 3019 in the same task gave the probably error of only 0'29. They ascribe this to the greater rigidity and better optics of the Russian theodolite⁽⁴⁶⁾.

From such a statement the only legitimate conclusion is that Aerogeopribor No. 3019 is better than Wild No. 159, but not that the Aerogeopribor instruments are generally better than Wild instruments. However, the Russians have undoubtedly performed many such tests and have come to the conclusion that they can dispense altogether with foreign made instruments. We can be sure that foreign made instruments are well known in Russia and are studied very carefully, and any good features are very promptly incorporated into their own instruments.

Approved For Release 1999/09/02 : CIA-RDP79-01083A000100050001-3

SECRET

SECRET

Approved For Release 1999/09/02 : CIA-RDP79-01083A000100050001-3

GRAVIMETRIC APPARATUS

The Russians put tremendous emphasis on the application of gravimetry to geodesy. This necessitates manufacturing of gravimetric apparatus on a much larger scale than is customary in most other countries. Soviet models are almost wholly based on apparatus manufactured abroad and the best available description in the textbooks^(47, 48) by L.V. Sorokin (1950 and 1951), one of the leaders in the field, gives no indication of revolutionary principles in the construction of such apparatus, with the possible exception of the gravimeter of Molodenskiy. There is, however, much evidence of Soviet cleverness in adaptation and improvement of already well-known instruments.

Free Pendulum Apparatus. All pendulum apparatus for the determination of gravity can be considered as a further development of the original pendulum of Sterneck. At least 30 such modifications are known and the Soviets do not claim originality in this respect. However, they have carried out extensive experimentation and introduced many substantial improvements.

One such improvement was the adaptation of the unwieldy Stückrath four-pendulum apparatus for field determinations. The original apparatus weighed over 200 klg., the Soviet model only 30 klg. It was used extensively for the pendulum gravity survey in Eastern Siberia, the Pamir Mountains and the Arctic and had a claimed precision of 1 to 2 milligals. Such pendulums are made in the shops of the Arctic Institute, but apparently they are used in all parts of the territory of the Soviet Union⁽²⁰⁾.

Approved For Release 1999/09/02 : CIA-RDP79-01083A000100050001-3

SECRET

SECRET

Approved For Release 1999/09/02 : CIA-RDP79-01083A000100050001-3

reached the U.S.S.R. in 1930. This instrument has been modified by the Soviets in its unessential details (recording device), but apparently it is substantially the same apparatus. It was used for submarine observations in the Black, Japan and Okhotsk Seas.

Determinations made for the Caspian Sea, however, involved the use of the Sorokin three-pendulum apparatus which was installed either on board a tanker or on a barge towed by steamers. This apparatus is not described in the literature except for a statement that it has brass pendulums. In all probability it is some modification of the Vening-Meinesz apparatus. Readings are said to be consistent if the weather conditions are favorable. It is worthy of notice that a statement is made concerning an extensive gravity survey of seas in 1949-50 with this apparatus. The Vening-Meinesz apparatus is also used to make observations on land in regions subject to frequent earthquakes.

Any kind of free-pendulum apparatus requires lengthy adjustments and the period of observation is very long. Soviet instructions for observations require continuous observations with the free-pendulum apparatus lasting at least 12 hours. Both in the U.S.S.R. and in the West many attempts have been made to develop an instrument that would reliably measure the force of gravity in a few minutes. In the following paragraphs only equipment used by the Soviets is described.

Fixed Pendulum Apparatus. This apparatus requires observations of the vibrations of a rod which is fixed at one end and supplied with a weight at the other. Its use was introduced into gravimetric practice by Father Lejay who made observations of this sort in China, the Phillipine Islands and France.

Approved For Release 1999/09/02 : CIA-RDP79-01083A000100050001-3

SECRET

SECRET

Approved For Release 1999/09/02 : CIA-RDP79-01083A000100050001-3
The principles of this instrument were further developed by G.J. Rudakovskiy, so that the Soviets now refer to this instrument as the Rudakovskiy Pendulum.

The Soviets say that they do not consider this instrument as very practical since it requires very careful handling and all sorts of precautions must be taken to insure dependable results. Very few such instruments are made in the U.S.S.R. and they are used in the general gravimetric survey. The theory and experimental results of observation with this gravimeter are described by M.E. Kheyfets⁽⁴⁹⁾. Mean errors of determination are of the order of 2 mg.

Static Gravimeters. The Soviets evidently have experimented with gravimeters which depend on a principle different from that of a pendulum. As of 1939 they started using gravimeters of the Ising and Boliden types; after the war, Mott-Smith, Heiland and Norgaard gravimeters. All of these were found to be unsatisfactory for one reason or another, and at the present time, Soviet gravimeters, GKM, GKA and VIRG are said to be in almost exclusive use.

GKM: This is the Molodenskiy gravimeter, apparently an independent Soviet development. The essential part of this apparatus is a flat ring, situated in the vertical plane. One point of this ring is attached to the stand of the apparatus, the other is connected with an elaborate lever with a weight. The difference in the force of gravity is measured by the pressure of this weight on the ring. The precision of the gravimeter is stated to be from 0.4 to 0.8 mg. The weight of the entire apparatus totals about 25 kg.

The ring of the gravimeter is made of elinvar (L-invar, a steel-nickel alloy with a very low coefficient of expansion). The ring and the lever are in a special chamber, the temperature of which is controlled by a thermostat

Approved For Release 1999/09/02 : CIA-RDP79-01083A000100050001-3

55
SECRET

accurate with the Federal Bureau of Investigation. Approved For Release 1999/09/02 : CIA-RDP79-01083A000100050001-3

for barometric compensation.

Readings by this gravimeter may be taken at any distance from the instruments by means of a special device, observations requiring about 5 minutes.

This gravimeter is extensively used for the determination of gravity on sea bottoms, the observer being situated aboard ship. No statement is made concerning depth of such observations.

The Molodenskiy Gravimeter is advertised⁽²⁰⁾ as being made by the Zavod Ministerstva Vooruzhennykh Sil (Plant of Ministry of Armed Forces), a rather interesting connection. The model described there is GKM-NIIPG-5, the weight 48 klg. The initials GKM mean: Gravimetr Kol'tsevoy Molodenskiy (Ring Gravimeter of Molodenskiy); NIIPG: Nauchno-Issledovatel'skiy Institut Prikladnoy Geofiziki (Scientific Research Institute of Applied Geophysics).

Testing of the Molodenskiy gravimeters was carried out in 1949 by N.P. Grushinskiy⁽⁵⁰⁾. There are evidently two types of these gravimeters; large models, PG-0 and PG-1, and small models, GKM-5 (No. 17 and 37 were used). They were compared with the gravimeters of Norgaard (Nos. 268, 270, 271 and 327). The results of the test are not given separately for the Soviet and for the Norgaard instruments, since one gravimeter in each group was found to be defective. Excluding these, we get

Norgaard mean error	0.12 mlg.
Molodenskiy " "	0.67 mlg.

The comparison is thus in favor of Norgaard. This is admitted by the Soviets. However, the Soviet instrument is undoubtedly serviceable and quite adequate for relative gravity determinations.

SECRET

Approved For Release 1999/09/02 : CIA-RDP79-01083A000100050001-3

by A.M. Lozinskaya. The improvements are in the astatization, lever, thermostat, etc. The weight of the gravimeter is 13 klg., and the precision of determination, 0.3 mlg. It is stated that the adjustment of the apparatus and the readings of gravity at a selected point, can be made within 3 minutes.

Metal Spring Gravimeters. These gravimeters feature a spring, the tension of which is modified by the change of gravity. The Soviets used such gravimeters as those of Heyland and of Lindblad-Malmquist, but apparently found them unsatisfactory. There is no record of Soviet development of this principle.

Quartz Gravimeters. Fused quartz can be used in gravimeters instead of metallic rings and springs but it has disadvantages in being very brittle and being subject to large variation in the coefficient of elasticity depending on temperature. This means a very careful protection of the quartz spring which is taken care of by a sensitive thermostat and immersion of the spring in special oil. The Soviet quartz gravimeter, VIRG, developed by Poddybnyy, Samsonov and Serov at the Vsesoyuznyy Institut Razvedochnoy Geofiziki (All-Union Institute of Prospecting Geophysics, abbreviation VIRG, hence the name of the instrument) appears to be a very carefully made instrument capable of a precision of 0.3 mlg. The weight of the entire instrument is 22 klg.

The Russians admit that the principle of this gravimeter is very much like that of the quartz gravimeter of Norgaard, but apparently their invention was made quite independently.

Approved For Release 1999/09/02 : CIA-RDP79-01083A000100050001-3

SECRET

SECRET

Approved For Release 1999/09/02 : CIA-RDP79-01083A000100050001-3
Variometers, used for the determination of the second derivatives of the

gravitational potential are used exclusively in geophysical prospecting but are not of great importance from the point of view of geodesy. The Soviets manufacture two types of these instruments, the so called Z- and C- variometers, which appear to be more or less copies of the well known instruments first designed by Schweidar. The Soviets do not claim any originality in this respect.

Variometers of type S-20 are made at the plant of the Ministry of Geology, SSSR.

Approved For Release 1999/09/02 : CIA-RDP79-01083A000100050001-3

58
SECRET

SECRET

Approved For Release 1999/09/02 : CIA-RDP79-01083A000100050001-3

APPENDIX IV

PHOTOGRAPHIC LENSES AND CAMERAS

Many types of photographic cameras are manufactured at several Soviet plants. Especially important is the optical-mechanical factory in Leningrad, Optiko-Mekhanicheskiy Zavod imeni OGPU, usually referred to in Soviet literature as GOMZ (Optical-Mechanical Plant). This plant has attached to it a large research laboratory in which problems of optics are intensively studied from the constructional point of view. The factory itself manufactures optical instruments such as binoculars on a wholesale scale and also individual instruments for research work. Industar Cameras Nos. 7, 13 and 17 manufactured here, are used for meteor study (for astronomical purposes as well as in connection with studies of upper atmosphere) and are claimed to be of high quality.

Much investigation and design of photographic cameras for photogrammetric purposes was done at the Leningrad Institute of Aerial Surveys before its merger with the Central Institute of Geodesy, Cartography and Aerial Survey in Moscow (TsNIIGAIK). The best known designer there is M.M. Rusinov. Practically all outstanding lenses for photogrammetry are of his design.

1. Photographic Lenses

Soviet development in photographic lenses, according to Soviet writers, followed approximately the same course as the development of other apparatus. At first, there was absolute dependence on foreign-made lenses, then came a more or less slavish imitation of Western production, and finally complete independence of the West was attained.

One way to increase the field of view of cameras for aerial photography is to combine several cameras into one unit. This introduces mechanical

Approved For Release 1999/09/02 : CIA-RDP79-01083A000100050001-3

SECRET

SECRET

Approved For Release 1999/09/02 : CIA-RDP79-01083A000100050001-3

difficulties as well as difficulties in the laboratory treatment of the photographs obtained. The Soviets considered the 4-lens apparatus by Zeiss and the nine-lens camera by Ashenbrenner and by Fairchild and, in fact, constructed their own 9-lens equipment. However, later development of Russian cameras has been concentrated on the use of single objectives.

Because of the difficulty encountered in systematizing heterogeneous Soviet material in which all lenses, both Soviet and foreign made, are grouped indiscriminately and the use of lenses not always indicated, it was decided to list all of the lenses which can be identified as of Soviet make. In the following tables, I to V, the notation is as follows:

f mm: focal length of the lens in millimeters

f/ : focal ratio

2β : angle of the field of view

Res. Power: resolving power in the center and on edges whenever ascertained

Size of photo: in centimeters

Camera: this is known in comparatively few cases.

In combining the data for tables I to V, many minor discrepancies were encountered. Results given in these tables represent our best efforts to reconcile these discrepancies, using all information available here at the present time.

Approved For Release 1999/09/02 : CIA-RDP79-01083A000100050001-3

SECRET

SECRET

Approved For Release 1999/09/02 : CIA-RDP79-01083A000100050001-3

SERIES "RUSSAR"

Designer: M. M. Rusinov

Application: Photogrammetry; scale 1:100,000 and smaller.

Claims: much larger usable field of view than in any other lenses.

Number of components: 6

Mark	fmm	f/	2 β	Resolv. Power		Size of Photo (cm)	Camera
				Center	Edge		
Russar 1a	100	5.3	140°	12		18 x 18	
Russar-5	120	4.5	104°	15		23 x 23	
Russar-16	60	12	126°	-	-	-	
Russar-19	100	6.3	103°	20	10	18 x 18	
Russar-22	70	8.0	122°	26	4	18 x 18	
Russar-25	98	6.8	110°	23	4	18 x 18	A Shch AFA-2
Russar-25a	70	6.8	122°	20	10	18 x 18	
Russar-26							
Russar-29	70	6.8	122°	26	12	18 x 18	RMK C-5
Russar-30	120	6.3	120°	30	17	30 x 30	33/20-MAFA 33/12
Russar-31							
Russar-33	100	6.8	122°	-	-	30 x 30	
Russar-Plasmat	210	3.5	70°				A Shch AFA-2

Approved For Release 1999/09/02 : CIA-RDP79-01083A000100050001-3

SECRET

Approved For Release 1999/09/02 : CIA-RDP79-01083A000100050001-3

SERIES "INDUSTAR"

Designer: unknown

Application: aerial surveying cameras, copy cameras

Claims: high resolving power, good illumination, small distortion

Number of components: 4

Mark	fmm	f/	28	Res. Power		Size of Photo (cm)	Camera
				Center	Edge		
Industar-2	135	4.5					
Industar-4	210	4.5	46°	30		13 x 18	AFANM
Industar-7	105	3.5					
Industar-10	50	3.5					
Industar-11	210-1200	4.5-9.0					Reproduction Camera for Cartography
Industar-13	300	4.5	56°	23		18 x 24	NAFA-13; AFA-13 13-EZ AFA-1
Industar-17	500	5.0		32		18 x 24	NAFA-3 _s
Industar-22	511	3.5	46°	40	20		FED; ZORKIY Reprod. App. PU-2
Industar-23	110	4.5	52°			6 x 9	MOSKVA-II
Industar-51	210	4.5	56°	16		13 x 18	AFA-IM; NAFA-19
Industar-A	500	5.0	46°	30		30 x 30	AFA-3 AFA #33/500

Approved For Release 1999/09/02 : CIA-RDP79-01083A000100050001-3

SECRET

SECRET

Approved For Release 1999/09/02 : CIA-RDP79-01083A000100050001-3

SERIES "URAN"

Designer: D. S. Volosov

Application: Aerial survey, possibly infra-red work

Claims: great speed

Number of components: 7

Mark	fmm	f/	28	Res. Power		Size of Photo (cm)	Camera
				Center	Edge		
Uran-4	250	2.5	54°				
Uran-9	250	2.5	54°	40		18 x 18	
Uran-10	100	2.5	60°				
Uran-11	250	2.5	54°				

TABLE IV

SERIES "YUPIITER" (Jupiter)

Designer: unknown

Application: general photography, connection with aerial photography not clear

Claims: nothing specific -- just a good lens

Number of components: 5

Mark	fmm	f/	28	Res. Power		Size of Photo (cm)	Camera
				Center	Edge		
Yupiter-3	52	1.5	45°			24 x 36	KIYEV
Yupiter-8	52	2.0	45°			"	KIYEV
Yupiter-9	85	2.0	28°			"	KIYEV
Yupiter-11	135	4.0	18°			"	KIYEV
Yupiter-12	35	2.8	63°			"	KIYEV

Approved For Release 1999/09/02 : CIA-RDP79-01083A000100050001-3

SECRET

SECRET

Approved For Release 1999/09/02 : CIA-RDP79-01083A000100050001-3

OTHER OBJECTIVES

Mark	fmm	f/	28	Res. Power		Size of Photo (cm)	Camera
				Center	Edge		
Rodina-2	46	8.2	140°			18 x 18	Photogrammetry?
Orion-1A	200	6.3	94°	42	4	30 x 30	AFA-33/20
Orion-1							
Ortagoz	135	4.5	55°				FOTOKOR
Equitar	250	2.5	48°				
Quarz	120	4.5					
Liar-6	100	5.4	100°				
Telemar-2	750	6.3	32°	30		30 x 30	AFA-33/75
Telemar-7	1000	7.0	24°	28		30 x 30	AFA-33/100
Telefoto-F3	400	4.5		24		13 x 18	
Ortodinar	210	2.0	56°				
Arktur	180	4.5		33		18 x 18	
Iniar	360	3.0					Infra-red
Arktik	51.8						
Gelios		1.35					
Luch	180						Phototransformer FTB
Tafar	100	4.5	93°	60	40	18 x 18	Photogrammetry

Approved For Release 1999/09/02 : CIA-RDP79-01083A000100050001-3

SECRET

SECRET

Approved For Release 1999/09/02 : CIA-RDP79-01083A000100050001-3

There is very little material available for comparison of Soviet lenses with those made in the West. Veselovskiy⁽³⁰⁾, 1945, gives the following comparison of Russar and Tafar with the Zeiss Topogon:

Table VI

SOVIET OBJECTIVES FOR PHOTOGRAMMETRY

Objective	fmm	f/a	2θ	Negative cm.	Res. Power	Distortion in 0.01 mm.
Russar 1a	100	5.3	140°	18 x 18	12	5-7
Russar 5	120	4.5	104°	23 x 23	15	5-7
Russar-19	100	5.3	104°	18 x 18	15-20	5-7
Russar-22	70	8	122°	18 x 18	15-20	1-2
Tafar	200	4.5	70	18 x 18	40-60	>1
Topogon	100	6.3	93	18 x 18	20-25	25-30

Off-hand, this table shows the great superiority of Russian lenses over the Zeiss lens and in fact the Russians are emphatic in stating this superiority. However, some modification must be introduced into this claim in order to arrive at a reasonable conclusion. This is done here by each lens separately.

Industar: this objective can be used for almost any kind of photographic work. It is made in different models, but there is little detailed description of any of them. It is stated⁽³⁰⁾ that this objective is part of the aerial camera, AFA-13, and has the focal length 300 mm., with the ratio f/4.5. Apparently it has proved unsatisfactory for precise photogrammetry and is seldom mentioned in the more recent literature on this subject. It appears

Approved For Release 1999/09/02 : CIA-RDP79-01083A000100050001-3

SECRET

SECRET

Approved For Release 1999/09/02 : CIA-RDP79-01083A000100050001-3
to be a copy of the Zeiss, Tessar, and is admitted to be such by the Soviets⁽¹¹⁾.

It is a very useful lens for various purposes and there is evidence of extensive experimentation with its design by the Soviets. Available data on the Industars are given in Table II.

Tafar: the situation is approximately the same. This lens was used in cameras of the TAPA type but in more recent literature it is rarely mentioned and one gets the impression that it is of small importance. This may be incorrect, since the lens is undoubtedly a good one.

Liar: Liar-6 was the first significant original contribution made by the Soviets. It was designed by Rusinov and Kozyrev in 1931 with a field of view 100° , $f/5.4$ and $f = 100$ mm. It is stated that Zeiss succeeded in producing its Topogon with the same field of view only in 1936. The Liar lens was designed for use in aerial surveying (scale 1:100,000)⁽⁵¹⁾ but later it was almost wholly supplanted by Russar objectives.

Rusinov is not the only designer of lenses for aerial photography at the TsNIIGAIK. Several other lenses for aerial photography are referred to in Russian literature but apparently they were proved unsatisfactory for mass production. Such are, for instance, the lenses designed by Yezhova ($f/18$, angle 110°) and Mindlina ($f/14$, angle 90°).

Russar. This is a really fine series of lenses and if the Soviet descriptions are to be trusted, they are among the finest wide-angle lenses in the world.

The claim of excellent performance for the Russar lenses is confined to their use in obtaining small scale aerial photography and can be summarized

SECRET

Approved For Release 1999/09/02 : CIA-RDP79-01083A000100050001-3
by stating that the whole field (or very nearly so) of view is usable because
of the following factors:

(a) The resolving power, while not as great in the center as in some Western lenses, remains practically the same almost to the edge of the plate. Curves of resolving power for Topogon, Orthometar, Russar-19 and Russar-15 are given in source (1).

(b) The falling off of the degree of illumination is not as rapid as in other lenses, being proportional to $\text{Cos}^3\beta$ rather than to $\text{Cos}^4\beta$. This subject is discussed at some length by Volosov⁽⁵⁾.

(c) Distortion is much smaller than in other lenses.

It is impossible to come to any definite conclusions in regard to these claims without much greater effort that seems advisable in connection with this project.

It is advisable that attention be paid to one fact that seems to indicate that the Soviets themselves do not quite believe what they say themselves. This statement relates to experimentation with the Russar lenses, (the latest known is Mark 33) all of which have approximately the same characteristics. If the original Russar 1 was as good as it is described by the Soviets to be, continuous small changes in design would seem to have been unnecessary.

The Industar, Tafar, Liar and Russar lenses are the only ones mentioned in sources (30) and (32) which refer to problems of photogrammetry and aerial surveying. No other lenses developed in the U.S.S.R. are mentioned in the professional journals, "Geodezist" and "Sbornik NIIPS". One is left with the impression that the Soviets have succeeded in developing a very fine lens like Russar, but have little else at all comparable to the great variety of photographic lenses in the Western world. This impression is altogether

Approved For Release 1999/09/02 : CIA-RDP79-01083A000100050001-3

SECRET

SECRET

Approved For Release 1999/09/02 : CIA-RDP79-01083A000100050001-3
erroneous, because a number of sources (52), (53), (54), dealing with military applications of photography, definitely indicate to the contrary. The Soviets have designed many other lenses which appear to be of high quality and are, in fact, stated to be superior to similar lenses made in other countries. Some of these lenses can be used for precise photogrammetric work and in all probability are so used.

This curious discrepancy in the description of the situation between the two kinds of sources may be ascribed to the strict censorship of everything that is in any way connected with military activity. It is quite impossible to believe that the Russian photogrammetrists did not know of such lenses. In the Russian encyclopedia, "Geodeziya", page after page is filled with analysis of foreign lenses while the Russian lenses, Arktik, Uran and Orion are not even mentioned. In the sources published by the military these same lenses are praised as the finest product of the Soviet optical industry.

An attempt has been made to correlate Soviet lenses with similar lenses made in the West.

The Soviet lens, Industar, appears to be very nearly the same as the Zeiss, Tessar; the Soviet lens, Orion, is practically identical to the Zeiss Topogon; the Soviet, Ortogoz, is very similar to the Zeiss Dogmar; and the Soviet, Uran's forward side is quite similar to the American lens, Ektar.

The question is then raised as to who first designed these lenses and who was the imitator. There can be no question but that the Soviets copied Zeiss lenses. The influence of American design is less obvious, and it is possible that both the Uran and the Ektar lenses can be traced to some original German planar. With the established fact of the originality of the Liar

SECRET

Approved For Release 1999/09/02 : CIA-RDP79-01083A000100050001-3
Approved For Release 1999/09/02 : CIA-RDP79-01083A000100050001-3
optics and are also very clever imitators.

However, we scarcely deal here with simple imitation. There is considerable evidence of a Soviet attitude which is very critical of the products of the West which would not permit the Soviets to accept the Western producers' claims on faith. Western lenses are very carefully discussed by Volosov⁽⁵⁾ and Tudorovskiy⁽⁶⁾. Volosov, for example, gives a detailed analysis of the Eastman Kodak lens, Aeroektar. He points out that the Aeroektar is based on Rudolf's planar and takes exception to Eastman's claim that the good performance of Aeroektar depends on the introduction of the new lanthanum glass, EK32 and EK33 for the fifth and sixth positive components. Volosov finds that replacement of these glasses by Soviet glass, TK11, results in practically the same performance of the lens. He admits that the introduction of the new types of glasses is the greatest development in the last 60 years but they should be used only when they are really needed. Investigations of these new types of glasses are being carried on in the U.S.S.R. as well as abroad.

The whole problem of ethics of imitation has no application here. The Soviets take from the Western world what they consider useful. There is no particular odium attached to copying foreign lenses and calling them something else. The Bausch and Lomb lens, Metrogon ($f/6.3$; $2\beta = 93^\circ$) looks very much like the Zeiss Topogon which has exactly the same focal ratio and field of view. It is, however, definitely stated that the design of the Metrogon is based on that of the Topogon, so that nobody is misled⁽⁵⁵⁾. The justification for the change in the name is that, if similar but not identical glass is used in the lenses, it is necessary to recompute the whole system. Following

SECRET

SECRET

Approved For Release 1999/09/02 : CIA-RDP79-01083A000100050001-3
the formulae of the original manufacturer, even if they are known in all de-

tail, is not possible. In this sense there cannot be direct copying of lenses and considerable creative work is necessary.

If we turn again to the Soviet situation we find that the Soviet reader, especially a young student, is likely to get an exaggerated idea of Soviet ability to produce good lenses. From all the mass of Soviet literature examined in preparation of this report only one statement has been found, and that in an astronomical source,⁽¹¹⁾ in which the author mentions the Zeiss lenses, Tessar and Dogmar, and says in parentheses that these lenses are known in the U.S.S.R. as Industar and Ortogoz. It is curious that in some sources the Zeiss Topogon is severely criticized while in others the Soviet Orion (which is nothing but a copy of the Topogon) is praised as one of the finest lenses manufactured in the U.S.S.R. It is impossible to decide without a much more detailed study whether such an attitude is simply a manifestation of nationalistic feeling or that the Soviets have succeeded in removing the defects of the original Zeiss design. Information collected on other lenses is not extensive.

Orion: as stated before, this appears to be a direct copy of the Zeiss Topogon. The Orion-la is used in the aerial camera, AFA-33/20. The focal ratio and the field of view are identical with those of the Topogon and Bausch and Lomb, Metrogon. The transmission coefficient is 0.75.

The resolving power in the center is 35, at the edge, (that is 45° from center) 4 lines/mm. The corresponding figures for the Metrogon are 55 and 28; that is, in respect to resolving power, the Metrogon is far superior to the Orion-la. There are no other data on the performance of the Orion lens, but it is possible that further improvements have been made.

Approved For Release 1999/09/02 : CIA-RDP79-01083A000100050001-3

SECRET

SECRET

Approved For Release 1999/09/02 : CIA-RDP79-01083A000100050001-3

Uran: (table 2) this is a very complex lens with seven elements and a rather small field of view. In comparison with the Ektar, its resolving power is greater in the center but falls off more rapidly toward the edge. The coefficient of transmission is 0.7; for the Ektar, 0.8. The field of view of the Uran-9 is only one-half of that of the Ektar, and it is rather puzzling why the Soviets praise the Uran lens so highly, unless some further improvements have been made. The range of achromatization suggests the use of the Uran lens for red and infra-red work.

Arktur: Nothing is known about this lens except the data given in Table 5.

Ortagoz: This is a copy of the Zeiss Dogmar and is used in Fotokor cameras. No description of this camera is available, but the camera is recommended for photography of meteors⁽⁵⁶⁾.

Arktik: Nothing is known about this lens except the focal length given in Table 5.

The name suggests some connection with the work in the Arctic regions.

Telemar: these are telephoto-lenses used in the AFA cameras. Data for Telemar-2 and Telemar-7 are given in Table 5. Both of these have a narrow field of view with fair resolution; Telemar-2, from 28 to 11 lines, and Telemar-7, from 28 to 17 lines. There is another telephoto-lens listed in Table 5, called the F3, which is apparently not of Telemar type, and may be the British triplet of the same mark.

Approved For Release 1999/09/02 : CIA-RDP79-01083A000100050001-3

SECRET

SECRET

Approved For Release 1999/09/02 : CIA-RDP79-01083A000100050001-3

Quartz Anastigmat: the only data so far found are given in table 5. It is not even certain that this lens is of Russian manufacture.

Iniar. This objective is specifically designed for photography in the infra-red and is mentioned only in one source⁽³²⁾. The data are given in Table 5. It is of an ordinary triplet type with elements separated and negative lens in the middle. From the data in Table II, it is evident that Industar-A has also been designed for the infra-red region. The design of the Iniar seems to be quite analogous to the British Triplet, F-24.

Rodina.* The name means, "Fatherland", a distinctly nationalistic connotation, but in fact it is a pun on the name of the designer, V.S. Rodin. This lens is mentioned in only one recent source (1) of 1952 and apparently is a new development. It is a very wide-angle objective, highly praised and quoted along with Russar-19, 22, 25, 25a, 29 and 33 as "an aerial photography objective." This may or may not mean photogrammetry. The drawing of Rodina-2 in source (1) shows eight components, two of which are plane, parallel slabs of glass. No more detailed description is available.

Jupiter: This series of lenses (table 4) is used in the ordinary camera, Kiev, and due to residual distortion, is of no application to aerial photography. For other lenses nothing is known beyond information contained in table 5.

The general conclusion of the study of Soviet lenses is as follows: the Soviets have some very excellent lenses of their own design and also many lenses more or less based on foreign patterns. These lenses may be as good or even better than the original Zeiss lenses. The Soviet boast, in this

* See Figure 10, page 106 of Photographic Supplement, Appendix VII.

Approved For Release 1999/09/02 : CIA-RDP79-01083A000100050001-3

SECRET

SECRET

Approved For Release 1999/09/02 : CIA-RDP79-01083A000100050001-3

of their ability to produce first-class optical instruments. It is also obvious that the data presented in this report are not complete and there may be other types of lenses for various purposes about which we know nothing. In this connection a significant remark is made in source (53). In discussing the possible application of mirrors in aerial photography in place of lenses, the authors point out that mirrors give a narrow field of view, but the high quality of images obtained, "make us believe that mirrors will find their application in aerial photography." Apparently there is some experimentation in this direction.

The related problem of astronomical equipment may be considered here for two reasons. The first is that there is less secrecy in the U.S.S.R. concerning this subject than concerning equipment for aerial photography. The second reason is that much closer contact between American and Soviet astronomers has been possible than in the case of almost any other science. Some astronomical equipment, such as image converters, may also well find its application in aerial photography.

A report on Soviet astronomical equipment has been prepared by Dr. Otto Struve, one of the outstanding American astronomers, and is reproduced substantially as submitted as Appendix 6. The general tenor of Dr. Struve's report is in good agreement with our appraisal of Soviet optical development. The report is of interest also, because it is an absolutely independent approach to the problem.

We may note here that in the recent general assembly of the Academy of Sciences, U.S.S.R., A. A. Mikhaylov, director of the Pulkovo observatory, definitely states⁽⁵⁷⁾ that Soviet astronomical equipment needs improvement

Approved For Release 1999/09/02 : CIA-RDP79-01083A000100050001-3

SECRET

so that the Soviet instruments can compete with ours. Approved For Release 1999/09/02 : CIA-RDP79-01083A000100050001-3

physical observation "as they have already surpassed them in the ideological and methodological respect." It would seem that the Soviets are conscious of this deficiency in astronomical instrumentation, at least in regard to large telescopes. The same idea was expressed without any reservations at the International Astronomical Union Assembly in September, 1952.

2. Color Filters

Color filters, adapted for use with aerial photography by the Russians are many but the situation in this respect is not very clear since different sources give different data. Much experimentation is going on with filters at the Optical Institute (GOI) and also at the Institute of Plastics (GIN PLASTMAS). Source (52) lists the filters used for aerial photography as though they were standard whereas source (32) describes an entirely different set of filters but only as applied to one particular camera, Tafa-2. Table VII contains information condensed from source (52):

Table VII

COLOR FILTERS USED IN AERIAL PHOTOGRAPHY IN THE U.S.S.R.

Filter	Mark	Spectral Region in μ	Color
I	ZhS-16	450 - 560	Blue-Yellow
II	ZhS-18	490 - 560	Blue-Yellow
III	OS-12	530 - 600	Orange
IV	OS-14	560 - 610	Orange
V	KS-14	620 - 609	Red

The following infra-red filters are mentioned: No. 66, GOI with transmission 780 - 900; KS-10, 600 - 1000, and KS-12, 900 - 1100 μ .

SECRET

Approved For Release 1999/09/02 : CIA-RDP79-01083A000100050001-3

The finest lens is of no use unless it is incorporated in a camera. This involves details of accommodation of the film, shutters with appropriate speeds, filters, etc.

MK and MAK-1. These cameras are reproductions of foreign apparatus (so admitted by the Soviets), the first being a copy of Zeiss, RMK 6-11, and the second, of Eastman Kodak, K-1. However, the Soviets used the Russar lenses in these cameras. These cameras were found unsatisfactory for many reasons and, after some little use for aerial surveys on scales of 1:50,000 and 1:100,000, they were discontinued. Soviet cameras are known as AFA (Aero-Foto-Apparat = Aerial Photo Camera). For precise photogrammetry, AFA-13, MAFA-17 and TAFA-2 are used.

AFA-13 was the first camera developed by the Soviets. It used the objective, Industar, was wholly automatic and weighed 30 klg. Because of its long focus objective (30 cm.) this camera can be used only for large scale photography on scales of 1:3,500 to 1:13,000.

MAFA-13 is the further development of the preceding camera, AFA-13. The long focus Industar objective is replaced by the short-focus Russar (10 cm.) to make it usable for surveys of scales of 1:25,000 to 1:100,000. The shutter is manufactured by the GOMZ. Both vacuum and mechanical clamping are used to flatten the film. Shutter speeds are 1/60 or 1/45 to 1/130. Efficiency is 90 percent. The frame size is 180 mm. sq., using 190 mm. film in rolls of 22.5 meter-lengths and 150 exposures. Intervalometer works 10 to 120 seconds and the gross weight of the camera is 80 klg.

Besides having fiducial marks, each negative has a statoscope and time recording made by an additional objective.

Approved For Release 1999/09/02 : CIA-RDP79-01083A000100050001-3

SECRET

SECRET

Approved For Release 1999/09/02 : CIA-RDP79-01083A000100050001-3
 The Soviets consider the main defects of this camera to be its limited

ability of the shutter and of the electric motor (0.1 HP fed by a 12-volt generator). Apparently there is also metering trouble and the method of impressing fiducial marks cannot be considered satisfactory.

TAFAs-2 is identical with the preceding, except that it has only one objective, the Russar-19, with shutter speeds 1/25 to 1/100, and with 90 percent efficiency. The size of the photograph is 23 x 23 cm. which, with the size of the roll as 24 cm x 50 meters, gives about 200 exposures.

For aerial reconnaissance many other cameras are used. Most of them are automatic and some of them appear to be of very fine design. Since there is an English translation available⁽⁵⁴⁾ of a very thorough description of most of these cameras, it does not seem advisable to go into great detail here and the most important data are given in Table IV. The Soviet notation, AFA 33/20 means AFA-33 with a camera lens of 20 cm. focal length. NAFA means Night AFA; that is, a camera for night work used with flares. AShch AFA means slit camera, known in the U.S.A. as the shutterless strip camera.

Table VIII

SOVIET AERIAL RECONNAISSANCE SHUTTERS

Camera	Lens	Kind	Speeds	Efficiency
AFA- 33/20	Orion-1a	Rotary	1/50, 1/100, 1/200	70 percent
AFA- 33/50	Industar A	Louvre	1/75, 1/100, 1/300	55 percent
AFA- 33/75	Telemar-2	Louvre	1/75, 1/100, 1/300	55 percent
AFA- 33/100	Telemar-7	Louvre	1/75, 1/125, 1/200	55 percent
AFA- 3s	Industar-A	Louvre	1/100, 1/200, 1/300	
AFA- IM	Industar-51	Curtain	1/200, 1/300, 1/400	67 percent
NAFA-3s	Industar-17	Louvre	1/50	60 percent
NAFA-13	Industar-13	Louvre	1/50	60 percent
DAFA-13-EZ	Industar-13	Louvre	1/50	80 percent
NAFA-19	Industar-51	Rotary	1/50	60 percent
A Shch AFA-2..	(Russar-Plasmat (Russar-25)			

Approved For Release 1999/09/02 : CIA-RDP79-01083A000100050001-3

SECRET

Approved For Release 1999/09/02 : CIA-RDP79-01083A000100050001-3

in a 1947 source⁽⁵⁴⁾ but is described in the source dated 1949⁽⁵³⁾ which means that it was presumably developed between these two years. It serves the same purpose as the American apparatus, S-7, but its constructional features are quite different. The lenses, Russar-Plasmat and Russar-25, are mentioned only in this connection.

In a source⁽⁵⁸⁾ which does not deal specifically with photogrammetry, the apparatus, A Shch AFA-2, is described at some length as one of the finest achievements of Soviet instrumentation. It was developed by V.S. Semenov who received a Stalin prize for its construction. The apparatus is definitely used for reconnaissance under conditions of poor illumination and low altitude when ordinary cameras are not usable. The record is obtained on continuous rolls of film, 10 to 45 meters long.

AD-2. This is a nine-lens apparatus designed by Drobyshev and used for surveys on scales of 1:100,000 to 1:200,000. The focal length of all cameras is 135 mm. with $a/f = 1:4.5$. There is a synchronized shutter with an efficiency of 82 percent. The combined field of view is 140° , and the negative size is 12 x 12 cm. The camera was designed and manufactured as early as 1931, but it is not mentioned in recent literature and is apparently not used currently. The Russian point of view is that the development of wide-angle Russar objectives wholly obviated the necessity of such cumbersome and expensive apparatus.

Approved For Release 1999/09/02 : CIA-RDP79-01083A000100050001-3

SECRET

SECRET

Approved For Release ~~1999/09/02~~ : CIA-RDP79-01083A000100050001-3

RADIO INSTRUMENTS

Instruments for the determination of position of the impulse type, and the continuous wave (C.W.) type have been developed by the Soviets but this development is surrounded by the utmost secrecy and it is very difficult to come to any definite conclusion as to the efficiency and originality of such instruments. The impression is, however, that the Soviet development is along the lines of C.W. rather than the impulse type.

Of the fact that instruments of this sort are being used in geodesy in the U.S.S.R., there can be no doubt. The official directions of the GUGK for the compilation of maps of scales of 1:200,000 and 1:100,000 specify the use for control of "astronomic and radiolocation points. Astronomic points should have mean errors not exceeding $\pm 1''$ in latitude and $\pm 0.5''$ in longitude. They should be corrected for the deflection of the vertical on the basis of gravimetric observations". Unfortunately nothing further is specified in regard to "radiolocation points".⁽²⁹⁾ Presumably they are expected to be of the same precision as the astronomical points. Many other statements of the same nature may be quoted but none of them is explicit enough to warrant a detailed analysis.

The related subject, that of radio-location as used at sea as of 1949 is discussed somewhat more thoroughly⁽⁵⁹⁾. This reference states that various instruments for the purpose of radio-navigation were developed by L. I. Mandel'shtam, N. D. Papaleksi and E. Ya. Shchegolev. These are the names usually quoted in connection with the development in radio-location on the surface of the earth. Instruments called "radiodalnomer" and "radiolag" are

78
Approved For Release 1999/09/02 : CIA-RDP79-01083A000100050001-3

SECRET

SECRET

Approved For Release 1999/09/02 : CIA-RDP79-01083A000100050001-3

Further, the system "Loran" is described but it is not clear whether it is used in the U.S.S.R. The illustration showing action of Loran has for its base, the map of the Eastern coast of America.

In 1930 Mandel'shtam and Papaleksi obtained a patent for the determination of position by means of radio using the phase-method. This method is based on the difference in phase of radio-waves received by the ship from sending stations A and B (a family of hyperbolas). This is compared with another system of hyperbolas based on the phase difference between the signals from another pair of stations C and D. The intervals between the stations are taken either as 100 or 200 km., depending on local conditions. On this principle several instruments were developed by Mandel'shtam and Papaleksi. One of these instruments, the so-called "Fazovyy Zond," was copied by the British and was called by them Decca or Navigator without any indication of the priority of Soviet scientists."

There is no description of this "Fazovyy Zond" beyond the statement that the main transmitting station is in the center of the triangle formed by the three subordinate stations, and that this apparatus is more precise than the "Navigator". At a distance of 200 to 300 km., the "Fazovyy Zond" is supposed to record positions "within a fraction of a meter". Observation is made visually as well as by a recording apparatus.

We have, then, from source (59) the names of three instruments used in the U.S.S.R., all of the C.W. type:

<u>Russian Name</u>	<u>Meaning</u>	<u>Approximate Western equivalent</u>
Fazovyy Zond	Phase Sonde	Decca
Radiolag	?	Lorac ?
Radiodal'nomer	Radio Range Measurer	Lorac

Approved For Release 1999/09/02 : CIA-RDP79-01083A000100050001-3

SECRET

SECRET

Approved For Release 1999/09/02 : CIA-RDP79-01083A000100050001-3

The apparatus is apparently based on the principle of change of phase angle of radio waves with the motion of one station in respect to the other; it is essentially a navigational instrument and as such is of no interest for geodesy.

The "radiodal'nomer" is based on the measurement of a number of phase cycles with the change of the wave-length of the sending station. This apparatus is of potential use in geodesy.

The "fazovyy zond", from its description, is hardly applicable to geodetic purposes.

Aseyev, ⁽⁶⁰⁾ in a book published in 1951, gives the theory of the interference method ("Fazovyy Zond") as well as the impulse method of radiolocation, (that is, the same principle as Shoran) but does not supply any description of instruments.

We have to consult pre-war sources to get any details at all about Soviet instruments for radio-location. Vodop'yanov, in his book "Radiolokatsiya", published in 1945, but which gives a statement that the situation described there refers to pre-war years, gives a few details about Soviet instruments ⁽⁶¹⁾.

The impulse range-finder of the Gouban type was developed at the Leningrad Section of the Institute of Communications in 1932 and was described by Bonch-Bruyevich in that year. It was used for the investigations of the ionosphere like the similar instruments of Breit and Tuve, and others. The apparatus of Mandel'shtam and Papaleksi is described in a general way but is considered as a further development of similar apparatus of Espenschied (1930) and Alford (1937).

The only data directly related to our problem have been found in a book ⁽⁶²⁾ edited by Mandel'shtam and Papaleksi and published in 1945. The experiments

Approved For Release 1999/09/02 : CIA-RDP79-01083A000100050001-3

SECRET

SECRET

Approved For Release 1999/09/02 : CIA-RDP79-01083A000100050001-3

the radio-geodetic labora-
tory of TsNIIGAIK conducted a series of experiments in 1936-39 with the instru-
ments, RIR-1 and RIR-2 (Radio Izmeritel' Rasstoyaniy = Radio Range Distance).
These were apparatus developed by Mandel'shtam-Papaleksi-Shchegolev and based
on the same principle as the "Radiodal'nomer" mentioned above. The develop-
ment of RIR, and apparently of other similar apparatus, took place in the
Laboratory of Radio-Physics, Leningrad Industrial Institute and in the Labora-
tory of Oscillations, Institute of Physics, Academy of Sciences, U.S.S.R. The
RIG-1 and RIG-2 apparatus was to be tested for geodetic applications and the
following tasks were set up:

(a) to reach a precision of from 5 to 10 meters in the measurement of
distances of 20 to 120 km. With a 5-meter precision in the first case, the
relative precision would amount to 1:4,000; in the second, 1:24,000. The
highest precision hoped for would just about satisfy the requirements of
first order triangulation.

(b) to preserve this precision under all physical and geographical con-
ditions.

(c) to develop methods of determination of geodetic positions for topo-
graphic and geodetic work.

(d) to develop and manufacture apparatus suitable for use under difficult
conditions.

As the result of these tests, problems (a) and (b) were considered solved
and the apparatus was recommended for mass production.

The description of actual tests confirms this optimistic attitude.

The following results of determination of distances are quoted with their
mean error:

Approved For Release 1999/09/02 : CIA-RDP79-01083A000100050001-3

SECRET

SECRET

Approved For Release 1999/09/09 : CIA-RDP79-01083A000100050001-3

Nara-Shalikovo	34,515 met.	± 0.5 met.	1:70,000
Nara-Kubinka	21,761	0.6	1:36,000
Pugachev-Gorelyy Gay	50,241	0.8	1:63,000

The only available description of the apparatus says that it is based on the measurement of the difference in phase of radio waves between the sending and reflecting station; that is, apparently of the "radiodal'nomer" type, and that the wave-lengths used were between 240 and 360 meters.

The small relative errors given above represent only consistency of measures. There is no comparison between geodetic distances and distances determined by the apparatus, RIG. In fact, the entire book is full of discussion about the uncertainty of the exact velocity of the propagation of radio-waves. Unless this point is settled all distance determinations made by means of radio-waves, are incorrect.

For the determination of distances at sea another apparatus, MPShch-4 and MPShch-6, was used. There are said to be similar to RIG. The letters are abbreviations of the names of Mandel'shtam-Papaleksi-Shchegolev, the inventors who, between 1932 and 1936, obtained eight patents on these devices. The precision obtained by means of this apparatus is not very impressive. At the distance of 113,740 meters between Cape Ray-Navolok and Island Ploskaya Luda (White Sea), discrepancies between the geodetic distance and the radio distance were from 10 to 160 meters, with a relative error of from 1:10,000 to 1:700.

Concerning the exact performance of the Soviet radio-instruments in actual geodetic practice, very little information can be obtained. Nesmeyanov

Approved For Release 1999/09/02 : CIA-RDP79-01083A000100050001-3

SECRET

SECRET

Approved For Release (S) 1999/09/02 : CIA-RDP79-01083A000100050001-3

and more correctly discussing the possible improvements of aerial surveying methods state definitely that a precision of 1:10,000 at a distance of 30 km. has been achieved by the method of radio-wave interference, and that all indications are that this method can be used for distances of up to 100-150 km. "In most regions radio-determinations in conjunction with astro-gravimetric positions allow development of a reliable geodetic network without the construction of trigonometric signals and reconnaissance work". Efficiency of this method is considered to be greater than that of ordinary geodetic methods.

Chebotarev, ⁽⁵⁶⁾ in 1948, says that, "the measurement of distances by the method of radio-wave interference has long ago been incorporated in geodetic practice and we have certain achievements in this direction".

A.Ya. Shchegolev, ⁽⁶⁴⁾ (not the inventor mentioned previously but apparently his brother) in 1946, speaks of distances up to thousands of kilometers that can be measured by radio-interference methods, obviously an irresponsible statement for public consumption. He says further: "The methods of radio interference developed by us (apparatus MPShch) are used in problems in which especially high precision is required: for hydrographic investigation of seas and for geodetic work. Such instruments will be applied in aerial surveying for the compilation of maps."

Fortunately we can more or less establish the precision in geodetic measurements made by radio methods as of the date, 1945. In that year on May 12th, N.D. Papaleksi delivered a paper on this subject at the meeting of the TsNIIGAIK ⁽⁶⁵⁾. The statement of this scientist is of much more value than is the indefinite boasting of popular writers.

It is evident from this paper that the problem of determination of distances by means of radio was taken up quite seriously by the Soviets. As early

Approved For Release 1999/09/02 : CIA-RDP79-01083A000100050001-3

SECRET

SECRET

Approved For Release 1999/09/02 : CIA-RDP79-01083A000100050001-3
as December 25, 1934 a special conference was organized by the TsNIIGAIK to

consider this problem. Many expeditions were sent out with the following institutions participating:

TsNIIGAIK (Central Institute of Geodesy, Aerial Survey
and Cartography)
Leningrad Polytechnical Institute
Institute of Physics, Academy of Sciences
Hydrographic Department, GLAVSEVMORPUT'

Especially important was the "recent" (1945?) expedition to the Caspian Sea where various types of apparatus were tested.

Papaleksi considers two pieces of equipment already described, both of which are based on the interference method: Radiodal'nomer and Radiolag, but only the first one is recommended for geodetic work. We have for this instrument:

$$D = K (\Delta\psi - \Delta\rho)$$

$$K = \frac{v}{720 \Delta f}$$

Δf = difference of frequency

$\Delta\psi$ = difference in phase

$\Delta\rho$ = correction due to physical condition of ground.

The precision of the measurement of distance D is determined by two factors:

- (1) precision of apparatus and method (Δf and $\Delta\psi$)
- (2) precision of determination of the velocity of waves, v , entering into constant K.

After careful consideration of the problem, Papaleksi comes to the conclusion that there is no difficulty in controlling factor (1). It is only necessary to go to shorter wave-lengths of the order of 1 or 2 meters and, theoretically at least, the instrument can be made as precise as needed. However, the other factor cannot be controlled because it involves physical

Approved For Release 1999/09/02 : CIA-RDP79-01083A000100050001-3

SECRET

SECRET

Approved For Release 1999/09/02 : CIA-RDP79-01083A000100050001-3
of the ground (conductivity and dielectric constant). Actual experiments conducted by the TsNIIGAIK resulted in a precision of 10 to 15 meters regardless of distance, over homogeneous ground and only of a precision of 20 to 30 meters over dissected areas, water, etc.

Papaleksi sees further development of the method by using microwaves (the line of sight limitation) and setting up apparatus on triangulation towers (40 meters high) to get away from the disturbance produced by the ground. Under such conditions geodetic distances of from 25 to 30 km. can be determined.

If we take the highest precision quoted by him (10 meters), and the distance 30 km., the relative precision is then 1:3,000, quite unsatisfactory for geodetic purposes. It is of the same order of magnitude as measures made in the White Sea in 1939. Papaleksi is aware of this and says plainly that the trouble is not with the instrument but with the variation in the velocity V produced by natural conditions. He advocates that prompt efforts should be made to solve this problem both theoretically and through experimentation.

In other articles he points out that the velocity V cannot be determined with a precision greater than 1 2,500 and until more is known, geodetic measures cannot be made precise enough for practical purposes.

Such was the status of the problem in the U.S.S.R. in 1945. Undoubtedly much experimentation on the determination of the velocity of propagation of radio waves is going on in the U.S.S.R., but nothing is allowed to get into print. In fact, a volume on the "Investigations on the Propagation of Radio-waves"⁽⁶⁶⁾ published in 1948, contains nothing but theoretical investigations, the only Soviet experiment quoted there being of 1945. The difference between

Approved For Release 1999/09/02 : CIA-RDP79-01083A000100050001-3

SECRET

SECRET

Approved For Release 1999/09/02 : CIA-RDP79-01083A000100050001-3

striking. More recent Soviet theoretical papers invariably quote experiments on the propagation of radio-waves made abroad rather than use their own results.

An interesting side-light on this problem is shown is a paper by O. A. Gerasimova, "Resume of experiments abroad in the application of radio-location methods in geodesy and cartography"⁽⁶⁷⁾ published in 1948. The author states that her report is based on 15 papers published in various foreign technical periodicals. The author discusses in detail the Wright Field tests of Shoran and the British GH. In all this detailed discussion there is not a word about the Soviet apparatus and not a hint whether the author considers the American and British results satisfactory or unsatisfactory. It is quite different from the usual boast that Soviet instruments are just as good or even superior to those made abroad. It is evident that the subject of radio determination of distances had become a state secret in the U.S.S.R. by 1948.

Since there is no detailed description of Soviet instruments later than those of 1939, nothing can be said about their merits in comparison with similar instruments made in the West. It is, however, clear that the Russians tried to adapt radio methods to geodesy at a much earlier date than was done in the U.S.A., and undoubtedly further experimentation with new models of RIG and MFSchch-6 has been conducted with more satisfactory results than those obtained in 1936-39.

Approved For Release 1999/09/02 : CIA-RDP79-01083A000100050001-3

SECRET

SECRET

Approved For Release 1999/09/02 : CIA-RDP79-01083A000100050001-3

SOVIET ASTRONOMICAL INSTRUMENTATION

General Remarks:

A considerable number of Soviet publications have been reviewed resulting in the following general conclusions:

a) Soviet instruments are of superior design in the field of photography with short focus lenses and in the construction of medium size meniscus-type Schmidt type telescopes. The Soviets have made no attempt to build any large instruments, but it would appear that the technological progress made since the end of the first world war has been sufficiently large to justify the belief that they could, without too much difficulty, build any instrument up to about 200 inches in aperture.

Particularly impressive are the image converters which have been used in practice in the U.S.S.R. but of which no detailed description has been found. From the results on the spectrum of the night glow and the observations of solar prominences at a wave length of 10,000 A, one would infer that they have surpassed in this particular field any instruments now available in the United States. Image converters for astronomical purposes are under construction at the Yerkes Observatory but thus far no results have been announced. In Paris successful image converters have been built by Lallemand, but from the available descriptions one would be inclined to believe that the Soviet image converters are superior in sensitivity and in wave length range.

The question of secrecy is one that becomes apparent as one systematically surveys the Soviet literature. One has the impression that the Soviets are permitted to refer rather freely to astronomical instrument construction,

Approved For Release 1999/09/02 : CIA-RDP79-01083A000100050001-3

SECRET

SECRET

provided ~~Approved For Release 1999/09/02 : CIA-RDP79-01083A000100050001-3~~

pre-war Russian factories and scientific departments of various organizations. On the other hand, instruments built in Germany by Zeiss or in U.S.S.R. by German firms that were moved from the eastern part of Germany to the Soviet Union are described without reference to the maker. In one case an impression was formed that a modern instrument described by the Soviets was actually built by Zeiss or by engineers who formerly were connected with Zeiss.

There is also an obvious tendency not to reveal the existence of any radio instruments which almost certainly exist but which have never been mentioned in any of the articles on this subject. It is quite clear that the Soviet radio astronomers, for example, Shklovsky, have access to all the modern techniques and that they are fully capable of exploiting these results.

The question which remains open is whether they are able to rule diffraction gratings of the kind now being made in this country at Johns Hopkins University and at the Mount Wilson Observatory. The only reference to a grating spectrograph does not indicate the source. It may be an old grating purchased outside of the U.S.S.R. before the war.

With regard to photographic plates, it is obvious that they manufacture several different kinds but that most of their own emulsions are slower than those made in the United States. The only exception appears to be a photo-visual emulsion developed by Martynov in collaboration with a U.S.S.R. plate manufacturing concern.

Manufacture of Optical Glass

a) For telescopes

D. D. Maksutov⁽¹²⁾ speaks of "pre-war experience...gained in the

Approved For Release 1999/09/02 : CIA-RDP79-01083A000100050001-3

SECRET

Approved For Release 1999/09/02 : CIA-RDP79-01083A000100050001-3
 making of three kinds of ultraviolet glass (Kron, K-8, Flint, F-1; and heavy flint, T F-1)" which were not only as good as foreign makes of UV glass but rather surpassed them in quality."

The optical constants of K-8 and F-2 are as follows:

Glass	$n_c - 1$	$\frac{n_D - 1}{\gamma_D}$	$n_F - 1$	$\frac{n_G' - 1}{\gamma_G}$	$n_F - n_c$	γ
K-8	0.51390	$\frac{0.51630}{0.7022}$	0.52196	$\frac{0.52646}{-0.5583}$	0.00806	64.06
F-2	0.61160	$\frac{0.61640}{0.7150}$	0.62844	$\frac{0.63869}{-0.6087}$	0.01684	36.60

This statement appears on page 57: "We have previously used mostly glass K-8 (for meniscus telescopes), but it should be possible to find some more favorable kind from among the many glasses made in our country."

b) For mirrors

It is probable that Maksutov has used some kinds of glass resembling our pyrex, but he prefers metals.

Metals for Mirrors

Maksutov describes experiments made in his laboratory with different metals and different forms of castings. Copper, then silver, and then stainless steel, were found to be free of the "edge-effect" due to changes in the temperature. "After 13 years of experimentation I have reached the firm conviction that it is impossible to obtain with glass a really high grade reflector, and that in the future, metallic mirrors will be largely used."

The largest mirror of metal described by Maksutov, has a diameter of 210 mm. This mirror was made of stainless steel: EZh-2 steel with impurities:

Cr	13 - 15 per cent
Ni	0.6 "
Si	0.7 "

SECRET

Approved For Release 1999/09/02 : CIA-RDP79-01083A000100050001-3

C 0.13 - 0.23 per cent
Hardness - 197 (Brinell's scale)

The parabolic mirror was made in three days, in 1937. There were no changes until 1943, when it became astigmatic after having fallen to the floor from a height of one meter. The problem of the internal stresses has not yet been adequately solved.

Aluminizing

These techniques were developed in the U.S.S.R. in 1934. Better methods, not described, are said to be under investigation. Also, the technique of making non-reflecting coatings for transparent optical parts is fully described.

Maksutov states that his laboratory makes the best "plane and non-spherical surfaces." He is prepared to extend the size of his mirrors to 3 meters.

Photoelectric Photometry

B. V. Nikonov and E. K. Nikonova describe⁽⁶⁸⁾ a new stellar photometer which employs a Russian-made photomultiplier (FEU - 17) having Caesium-sulphide photocathodes "which in its parameters surpasses the American made photomultiplier 931-A." The precision of astronomical measurements with this instrument is about the same as in the case of comparable American photometers. The limiting brightness is not stated, but is probably also similar to that of our own instruments.

Meridian Circles

L. D. Agafonova and A. I. Nefed'yeva⁽⁶⁹⁾ describe the old meridian circle at Kazan. This instrument was built by Repsold in 1845, and it is still in use. From this work it is possible to infer that no major fundamental

Approved For Release 1999/09/02 : CIA-RDP79-01083A000100050001-3

SECRET

SECRET

Improvements have been introduced in Russia in the construction of meridian
Approved For Release 1999/09/02 : CIA-RDP79-01083A000100050001-3
telescopes.

Heliometers

These instruments have been long ago abandoned in most countries. At Kazan - Engelhardt, A. A. Nefed'yev⁽⁶⁹⁾ describes current investigations which are in progress with a heliometer constructed by Repsold in 1874. In this respect there has been no new development in the Soviet Union.

Electronic Image Converters

Writing in the American Scientist⁽⁷⁰⁾ about recent work on the night glow of air, J. Kaplan remarked: "Krassovsky, working in Russia, observed the O-2 band at 9976 Å, an accomplishment that must be noted with special interest, when it is realized that the most intense infrared emission at 10,440Å, first observed by Stebbins, Whitford, and Swings in 1944, would require 1,000 hours exposure of a hypersensitized Eastman 1-Z plate and an f/1 spectrograph having a dispersion of 2000/Å mm. Krassovsky accomplished his important observations by using a prismatic spectrograph and Cs-O-Ag electron image converter."

An image converter was also used by G. S. Ivanov-Kholodnyy⁽⁷¹⁾ for recording the infrared line of He I, λ 10830 in solar prominences. The dispersion was 8 Å/mm. No details of the converter are given.

Schmidt Telescopes and Maksutov-Type Meniscus Telescopes

A Schmidt telescope, constructed by Maksutov in 1937, for the Kazan-Engelhardt Observatory is described by D. Ya. Martynov in Izv. Engelhardt-Kazan, No. 27, 1951. The diameter of the correcting plate is 381.5 mm, that of the spherical mirror is 517.7 mm; f/2.5. The plateholder contains a field-flattening lens. The instrument is in all respects comparable to Schmidt telescopes of similar size in the U.S.A.

SECRET

Photographic Plates and Materials

Approved For Release 1999/09/02 : CIA-RDP79-01083A000100050001-3

Martynov, in a description of the Kazan-Engelhardt Schmidt telescope, states that Agfa-Astro plates are used, also Ilford Fine Grain Ordinary HD 45 - for blue-violet light. Apparently these are faster than Soviet made emulsions. But in the red region he uses Soviet Panchromatic film HD 900.

A photovisual emulsion similar in sensitivity (with respect to λ) to the human eye was developed by Martynov in collaboration with "the scientific laboratory of factory No. 8." The sensitivity was very great (mag. 15.6 pv in 10 minutes). On blue sensitive Agfa Astro the same instrument gives mag. 16.0 pg. in 5 minutes. As far as could be judged, German made color filters have been used in this work.

O. A. Mel'nikov has used Kodak 103a-0 plates with his new (1949) u.v. spectrograph⁽⁷²⁾.

G. S. Badalian⁽⁷³⁾ uses Agfa Astro and Panchrom. plates of German make, with "Aurantia" filter, probably also of German make.

Horizontal Telescope

Sh. T. Khabibullin describes such a telescope⁽⁶⁹⁾. Its purpose is the study of the physical libration of the moon.

The precision-coelostat was built by the Soviet factory, GOMZ. The aperture of the plane mirror is 300 mm. The stability of the reflected ray was guaranteed to $\pm 1''$, but actually gives only 5" to 7".

The photographic aplanatic objective of $f = 8000$ mm, $f/65$ was made according to Kazan Obs. specifications, but the name of the maker is not given.

During the observations serious difficulties were encountered with the seeing.

Approved For Release 1999/09/02 : CIA-RDP79-01083A000100050001-3

SECRET

Approved For Release 1999/09/02 : CIA-RDP79-01083A000100050001-3

O. A. Mel'nikov and B. K. Ioannisian describe⁽⁷²⁾ a new slitless UV spectrograph and its tests made at high elevations.

The telescope of 250 mm aperture consists of a parabolic mirror and Cassegrain secondary, quartz Cornu-type prism and a quartz doublet lens, aperture 46 mm, $f = 280.1$ mm.

Photographs of the completed instrument resemble pre-war telescopes made by Zeiss. The specifications were made by Mel'nikov at Pulkovo and his collaborators. In 1946 "the Pulkovo Observatory requested B. K. Ioannisian to design the telescope....." The construction was completed in 1946-47 "in the factory, with the close participation of P. V. Dobychin."

The tests were made at an elevation of 3250 meters in Armenia, in 1949. The results indicate essentially what might have been expected: Somewhat improved penetration into the UV region of stellar spectra, but never short of λ 3000. An identical instrument was built for the Byurakan Observatory⁽⁷⁴⁾, but again the maker's name is omitted.

Photographic Telescopes

Bull. Stalinabad Astr. Obs. No. 2 (1952) mentioned the installation of a new Zeiss astrograph "Triotar" ($D = 92$ mm, $f/4.5$)

G. S. Badalian⁽⁷³⁾ uses an "Ernostar" 5-inch astrograph of German make.

Spectroheliograph

G. A. Monin and A. B. Severnyy⁽⁷⁵⁾ describe a new spectroheliograph constructed in the shop of the Simeiz Observatory. The solar image is formed by a 20 cm parabolic mirror and has a diameter of 8 cm. The collimator and camera are 15 cm aperture mirrors with $f = 6$ meters. The dispersing unit is

Approved For Release 1999/09/02 : CIA-RDP79-01083A000100050001-3

SECRET

a plane gratings 50 x 70 mm in size with 600 lines per cm. The maker of the
Approved For Release 1999/09/02 : CIA-RDP79-01083A000100050001-3
grating is not stated - probably it is not of Soviet manufacture.

Radio-Astronomy

Observations of meteors are mentioned by A. Savrukhn⁽⁷⁶⁾ "For radio-acoustic observations a receiver of the type "Record" was used. A vertical antenna (aluminum tube 7 meters in length and 50 mm in diameter) was connected with the receiver. No trace of acoustic effects was found in the range of short waves used (10 mcge) from meteors of apparent magnitudes, -1, -2, -3 and even -7.

Approved For Release 1999/09/02 : CIA-RDP79-01083A000100050001-3

SECRET

SECRET

Approved For Release 1999/09/02 : CIA-RDP79-01083A000100050001-3

APPENDIX VII

PHOTOGRAPHIC SUPPLEMENT

Approved For Release 1999/09/02 : CIA-RDP79-01083A000100050001-3

SECRET

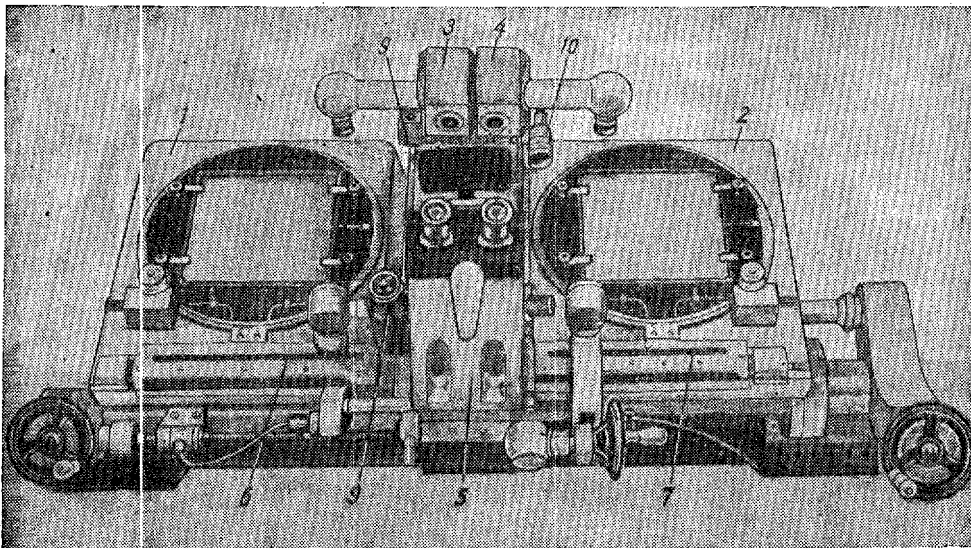

Fig. 1 - Oblique Stereocomparator
 ("Naklonnyy Stereokomparator")

- | | |
|--|---|
| 1. Carriage of Coordinates x_1 | ("Karetka Koordinat x_1 ") |
| 2. Carriage of Parallaxes | ("Karetka Parallaxsov") |
| 3. and 4. Movable Parts of the Objective of the Binocular | ("Podvishnyye Chasti Ob'yektiva Binokulyara") |
| 5. Immovable Binocular | ("Nepodvishnyy Binokulyar") |
| 6. and 7. Glass Scales 6 and 7 | ("Steklyannyye Shkaly 6 i 7") |
| 8. Transverse Scale 8 | ("Poperechnaya shkala 8") |
| Note: This is called "shkala 8 in the text but appears as "9" in the photograph. | |
| 9. Microscope 9 | ("Mikroskop 9") |
| 10. Parallax Screw 10 | ("Parallakticheskiy Vint 10"). |

Source: Drobyshev, F.V., Fotogrammetricheskiye Pribory i Instrumentovedeniye. Moscow, 1951.

Approved For Release 1999/09/02 : CIA-RDP79-01083A000100050001-3

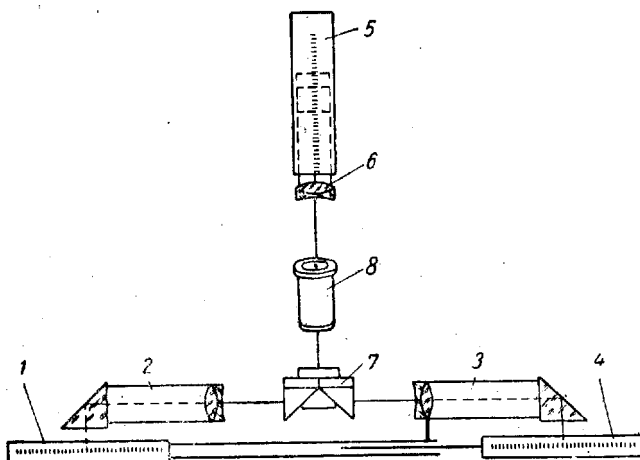

Fig. 2 - Design of the Optical Lay-out for Readings of Coordinates and Parallaxes in the "Naklonnyy Stereokomparator", (Oblique Stereocomparator).

("Skhema opticheskogo ustroystva dlya otschetov koordinat i parallaks v naklonnom stereokomparatore").

- | | |
|--|--|
| 1. Scale x_1 ; | ("Shkala x_1 "). |
| 2. Immovable Optical System for Scale x_1 ; | ("Nepodvizhnaya Opticheskaya Sistema dlya Shkaly x_1 "). |
| 3. Optical System of Carriage of p (Parallaxes); | ("Opticheskaya Sistema Karetki p "). |
| 4. Scale of Parallaxes p ; | ("Shkala Parallaksov p "). |
| 5. Scale of y_1 ; | ("Shkala y_1 "). |
| 6. Optical System for Scale of y_1 ; | ("Opticheskaya Sistema dlya Shkaly y_1 "). |
| 7. Block of Three Prisms; | ("Blok iz trekh prizm"). |
| 8. Microscope; | ("Mikroskop"). |

Source: Drobyshev, F.V., Fotogrammetricheskiye Pribory i Instrumentovedeniye. Moscow, 1951.

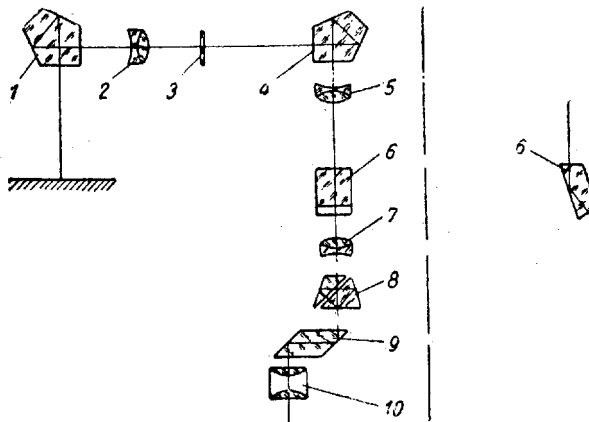

Fig. 3 - Optical System of the Oblique Stereocomparator.
 ("Opticheskaya Sistema Naklonnogo Stereokomparatora").

- | | |
|---------------------------------|-------------------------------------|
| 1. Pentagonal Prism; | ("Pentaprizma"). |
| 2. Small Objective; | ("Malyy Ob'yektiv"). |
| 3. Mark; | ("Marka"). |
| 4. Pentagonal Prism; | ("Pentaprizma"). |
| 5. Objective; | ("Ob'yektiv"). |
| 6. Prism; | ("Prizma"). |
| 7. Objective; | ("Ob'yektiv"). |
| 8. Prism with Five Reflections; | ("Prizma s Pyat'yu Otrazheniyami"). |
| 9. Rhombic Prism; | ("Rombicheskaya Prizma"). |
| 10. Ocular (Eyepiece); | ("Okulyar"). |

Source: Drobyshev, F.V., *Fotogrammetricheskiye Pribory i Instrumentovedeniye*. Moscow, 1951.

SECRET

Approved For Release 1999/09/02 : CIA-RDP79-01083A000100050001-3

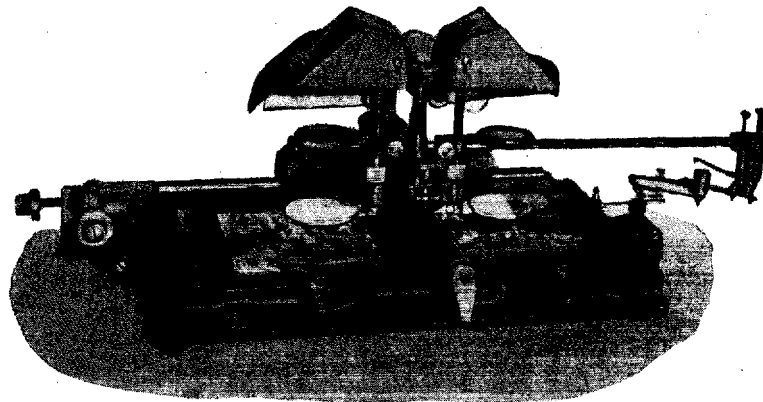

**Fig. 4 - The Drobyshev Stereopantometer SPD-1.
("Stereopantometr SPD-1 Drobysheva").**

**Source: Katalog-Spravochnik Laboratornykh
Priborov i Oborudovaniya.
Mashgiz, 1949.**

Approved For Release 1999/09/02 : CIA-RDP79-01083A000100050001-3

SECRET

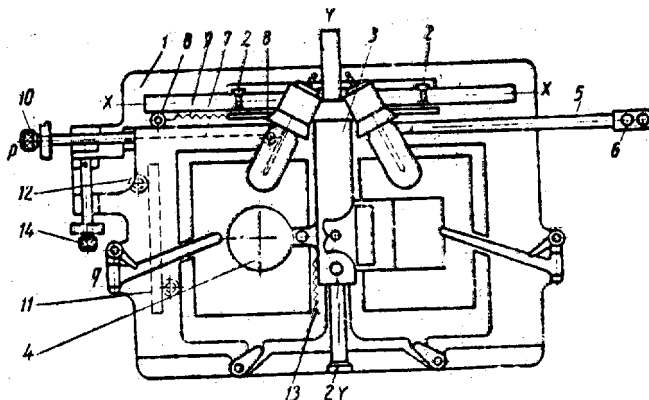

Fig. 5 - Working Parts of the Drobyshev Stereopantometer SPD-1.

1. Frame 1;
("Stanina 1")
"The device is set up on a drawing board which has two windows, located counter to the windows of frame 1, which serve for the lighting of the negative."
2. Carriage 2;
("Karetka 2")
"Along the X - X axis is located the circular track for support of carriage 2, which consists of a holder, of two rollers, of a transverse track and of a supporting ball-bearing roller. This carriage has three points of support and moves along the X - X axis."
3. Carriage 3;
("Karetka 3")
"Carriage 3, consisting of a holder and of two rollers and a rod 5 with a pencil 6, also has three points of support and moves on carriage two along the Y - Y axis."
4. Transparent Disks 4;
("Prozrachnyye Krushki 4")
"Carriage 3 carries supports with transparent disks 4, in the center of which are points which are measuring marks."
5. Rod 5;
("Shtanga 5")
See No. 3, above.
6. Pencil 6;
("Karanash 6")
See No. 3, above.
7. Plate 7;
("Plastina 7")
"Plate 7, with a projection pressed by roller 8 with the aid of spring 9, has a parallax device".

8. Roller 8;
("Rolik 8") See No. 7, above.
9. Spring 9;
("Prushina 9") See No. 7, above.
10. Screw 10;
("Vint 10") "Screw 10 pushes into plate 7 and measures the longitudinal parallax P of the photograph by way of moving along the X - X axis of plate 11, which has a projection which is pressed by rollers 12.
11. Plate 11;
("Plastina 11") See No. 10, above.
12. Rollers 12;
("Roliki 12") See No. 10, above.
13. Spring 13;
("Prushina 13") "With the action of spring 13 screw 14 pushes into plate 7 and measures the transverse parallax P by way of moving the photograph along the Y - Y axis."
14. Screw 14;
("Vint 14"). See No. 13, above.

Source: Katalog-Spravochnik Laboratornykh Priborov i Oborudovaniya. Mashgiz, 1949.

SECRET

Approved For Release 1999/09/02 : CIA-RDP79-01083A000100050001-3

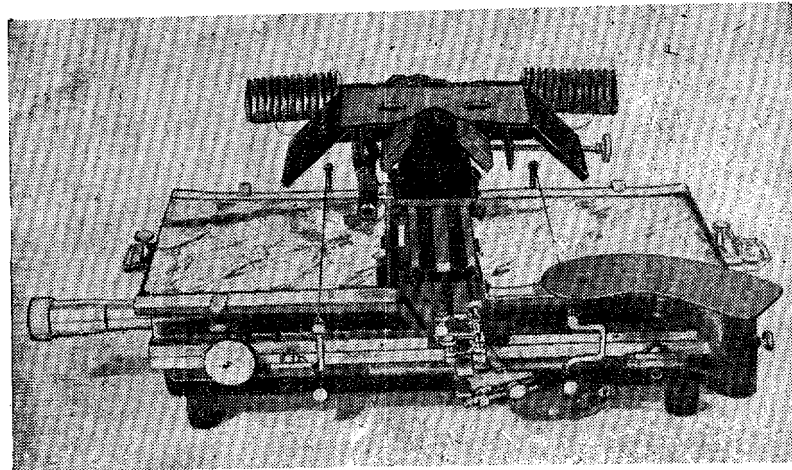

Fig. 6 - Topographic Stereometer
("Topograficheskiy Stereometr").

Source: Drobyshev, F.V. - Fotogrammetricheskiye Pribory
i Instrumentovedeniye.
Moscow, 1951.

Approved For Release 1999/09/02 : CIA-RDP79-01083A000100050001-3

SECRET

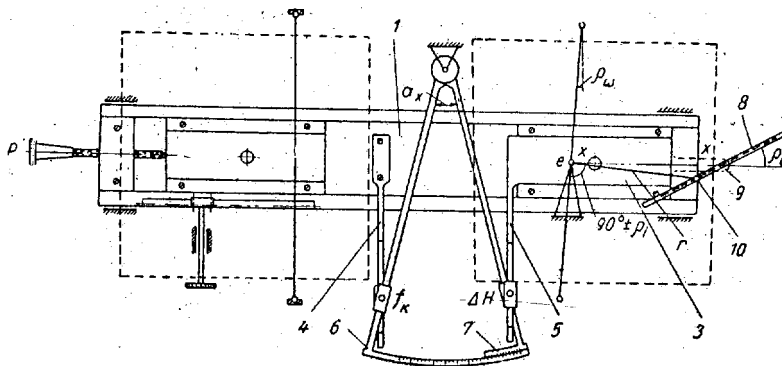

Fig. 7 - Design of Topographic Stereometer.
 ("Skhema topograficheskogo Stereometra").

Source: - Drobyshv, F.V. - Fotogrammetricheskiye Pribory
 i Instrumentovedeniye. Moscow, 1951.

1. Base Carriage; ("Osnovnaya Karetka").
 2. Support of Longitudinal Parallaxes; ("Support Prodol'nykh Parallaxov").
 3. Repeating Support; ("Povtoritel'nyy Support").
 4. Rod, Carrying Slide f_k ; ("Sterzhen', Nesushchiy Dvishok f_k ").
 5. Rod, Carrying Slide ΔH ; ("Sterzhen', Nesushchiy Dvishok ΔH ").
 6. and 7. Rulers of Convergent Device; ("Lineyki Konvergentnogo Ustroystva").
 8. Correction Ruler; ("Korreksionnaya Lineyka").
 9. Rotation Axel (Pin) of the Correction Ruler; ("Os' Vrashcheniya Korrektsionnoy Lineyki").
 10. Guide Roller; ("Vedushchiy Rolik").
- e - Center of Rotation of Wire Holder; ("Tsentr Vrashcheniya Nitederzhatelya").
- ρ - Screw of Longitudinal Parallaxes; ("Vint Prodol'nykh Parallaxov").
- r - Run of Level of T-shape Device; ("Dlina Rychaga T-obraznogo Ustroystva").

SECRET

Approved For Release 1999/09/02 : CIA-RDP79-01083A000100050001-3

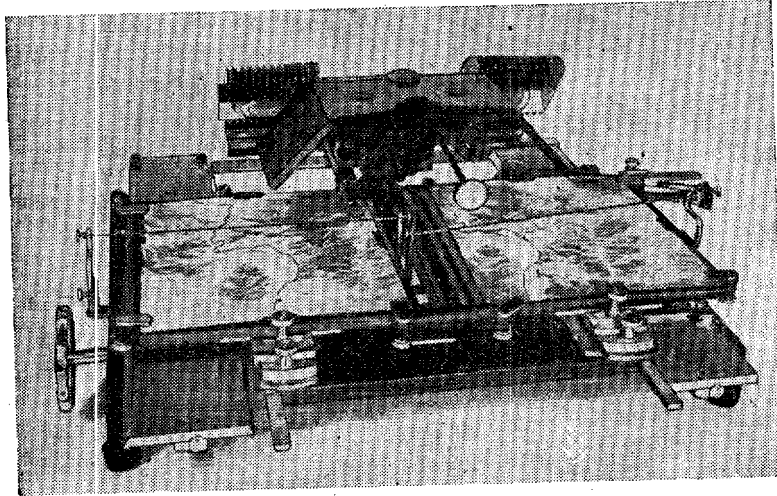

Fig. 8 - Kern Stereometer
("Kern-Stereometr").

Source: Drobyshev, F.V. - Fotogrammetricheskiye Pribory
i Instrumentovedeniye.
Moscow, 1951.

Approved For Release 1999/09/02 : CIA-RDP79-01083A000100050001-3

SECRET

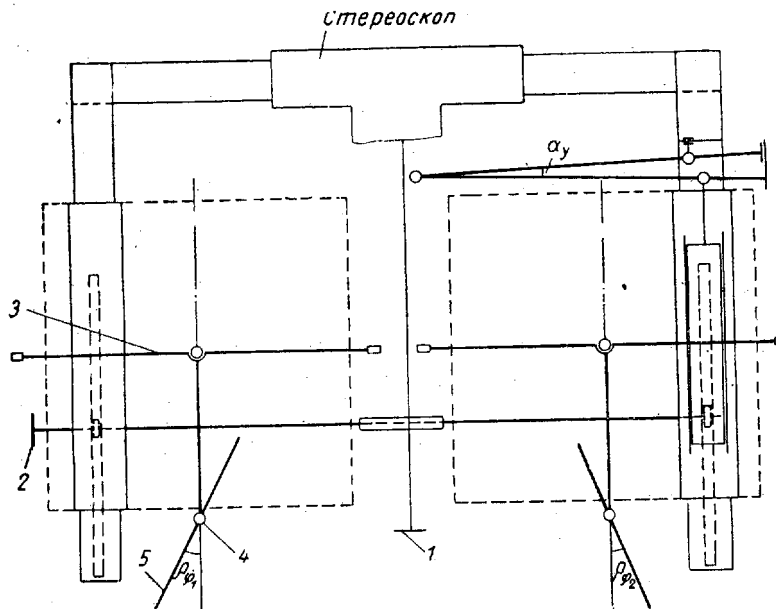

Fig. 9 - Design of Kern Stereometer.
 ("Skhema Kern-Stereometra").

- | | |
|----------------------|-----------------------------|
| 1. Rack Screw; | ("Vint Kremal'yery"). |
| 2. Hand Pilot Wheel; | ("Shturval"). |
| 3. Wire-holder; | ("Nitederzhatel"). |
| 4. Roller; | ("Rolik"). |
| 5. Correction Ruler; | ("Korreksionnaya Lineyka"). |

Note: The word at the top of the drawing is: Stereoscope
 ("Stereoskop").

Source: Drobyshev, F.V. - Fotogrammetricheskiye Pribory i
 Instrumentovedeniye.
 Moscow, 1951.

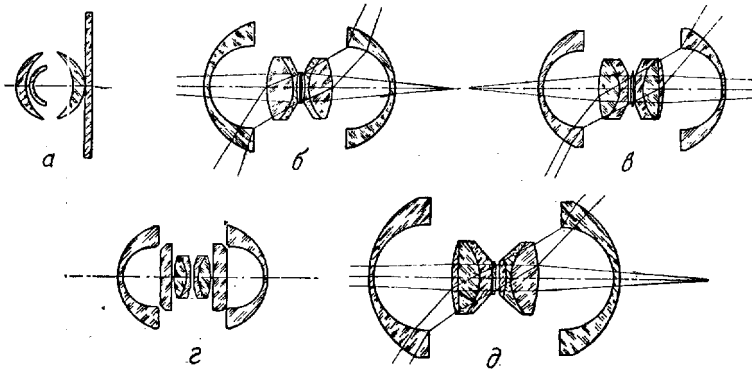

Fig. 10 - Various Kinds of Aerial Survey Objectives.
 ("Razlichnyye Vidy Aeros"yemochnykh Ob"yektivov.").

- a (" a ") - "Russar-19";
- b (" б ") - "Russar-25";
- c (" в ") - "Russar-29";
- d (" г ") - "Rodina-2";
- e (" д ") - "Russar-31".

Source: Mikhaylov, V. Ya. - Fotografiya i Aerofotografiya,
Moscow, 1952, Geodezizdat.

~~CONFIDENTIAL~~

Approved For Release 1999/09/02 : CIA-RDP79-01083A000100050001-3

~~SECRET~~

~~SECRET~~

Approved For Release 1999/09/02 : CIA-RDP79-01083A000100050001-3