

25X1

CONFIDENTIAL

Approved For Release 2003/01/28 : CIA-RDP78B04747A002900040051-0

02 977023

184/66

copy 25X1

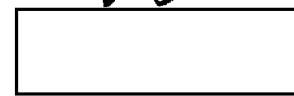

25X1

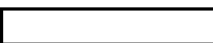

REGISTERED

2 December 1966

25X1

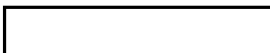

Subject: Measurement Improvement of  Stereo Viewer

25X1

Gentlemen:

25X1

As has been discussed verbally on several occasions, the measurement accuracy of the  Machine could be improved through additional efforts. The two approaches described below each have their individual advantages. In the case of the first approach, it is an immediate fix but does not have a long term advantage. The second approach (cam adjusted) has a long term advantage in that further measurement improvement and/or calibration can be made quickly as a function of machine usage, wear, and basic aging of machine parts.

Approach 1 - Shimming

25X1

Since the principal cause of error in the measuring capabilities of the  Machine is due to slight distortion in the ways, refinement in the machine geometry can be accomplished. The basic method of refinement is to measure the slight distortion and shim the ways sufficient to bring this distortion to a minimum. This is a time consuming and temporary approach since time and use will cause further distortions and require further shimming. It has a further disadvantage in that it will require the machine to be down for a period of at least two weeks and probably four weeks for each corrective action on each Y axis. With respect to the X axis, the down time is greater by a factor of two.

Cost analysis sheets applicable to the estimated time to accomplish each axis shimming are attached. We have estimated some four weeks of effort. If all four axes are accomplished at the same time, the calendar time would not be additive; some overlapping effort could be achieved, thereby reducing the total time to approximately four months for all four axes.

Declass Review by NIMA/DOD

CONFIDENTIAL

GROUP 1 EXCLUDED FROM AUTOMATIC DOWNGRADING AND DECLASSIFICATION

25X1

~~CONFIDENTIAL~~

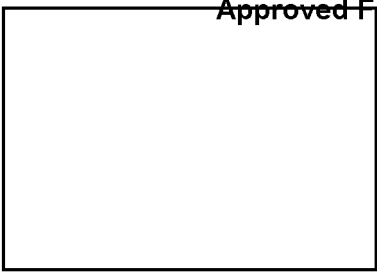



2 December 1966

Approach 2 - Cam Adjustment

Because of the detailed effort and extensive down time required to accomplish the shimming operation, another approach was taken to negate the errors and accomplish the program with minimum down time and with major long term effect. This approach is to design a cam which is attached to the basic machine and carriage in such a way that as a function of distance moved the zero of the encoder is changed and thereby provides the output to the encoders and computer calibrated to the basic errors of the machine. A drawing of the configuration of the cam device is attached. As shown in the figure, a fixed roller attached to the carriage drives a pivotally mounted cam that, in turn, actuates a rotatably mounted encoder. The cam function would include the average composite error of ways and screw for the axis it serves. The unique feature of this method allows change and reduction of error in a controlled manner without disturbing optics or other mechanisms of system. Cams and mechanism will be accessible for modification or servicing.

It should be pointed out that the cost analysis sheet attached for this approach is for all four axes and is based on using a straight cam to provide a straight line approximation of the errors and adjust accordingly. The cam could be shaped to further reduce the errors to an absolute minimum, based on a detailed calibration of the equipment. We have not estimated this approach since we understand that if all four axes can be brought to within a maximum accuracy of eight microns, further refinement is not necessary. We have estimated that the machine down time to accomplish the installation of all four cams and associated hardware would amount to two to three weeks. The total contract time would be two to three months to prepare the hardware  obtain the purchase items, and perform the installation.

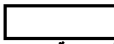
25X1

It is  firm opinion that a greater degree of measurement accuracy could be obtained using the cam adjustment approach, a considerably less down time, and a means of easily recalibrating the  Machine as a function of time and wear. It also offers the opportunity at a later time to shape the cams to provide greater accuracy than initially proposed herein.

25X1

25X1

The quotation submitted herewith is valid for sixty days from the submission of this letter and is based upon 75% progress payments, based on total cost incurred during any monthly period. The contract is based on a total estimated time of three months for the cam approach from date of award to complete installation in your facility. If we can provide any additional information or establish a meeting to discuss this matter in detail, please do not hesitate to contact us.

Very truly yours,

LHB/aw
Encl: (2) Cost Sheets 1 & 2
Fig. #1

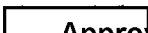
cc:  w/enclosure



25X1

25X1

~~CONFIDENTIAL~~

Executive Vice President

Next 1 Page(s) In Document Exempt

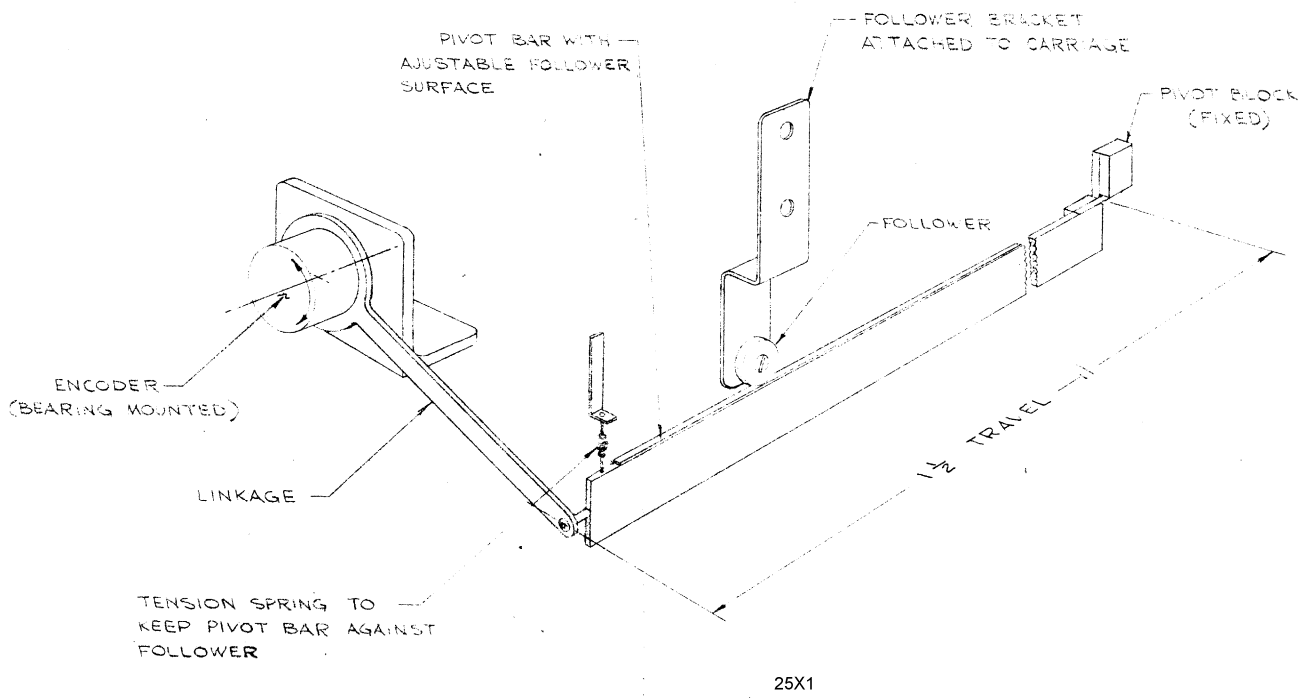

FIG. #1
(CAM ADJUSTED ENCODER MOUNTING)