

**BEST COPY**  
*Available*

Declass Review by  
NIMA/DOD

A  
PRESENTATION  
OF

STATINTL

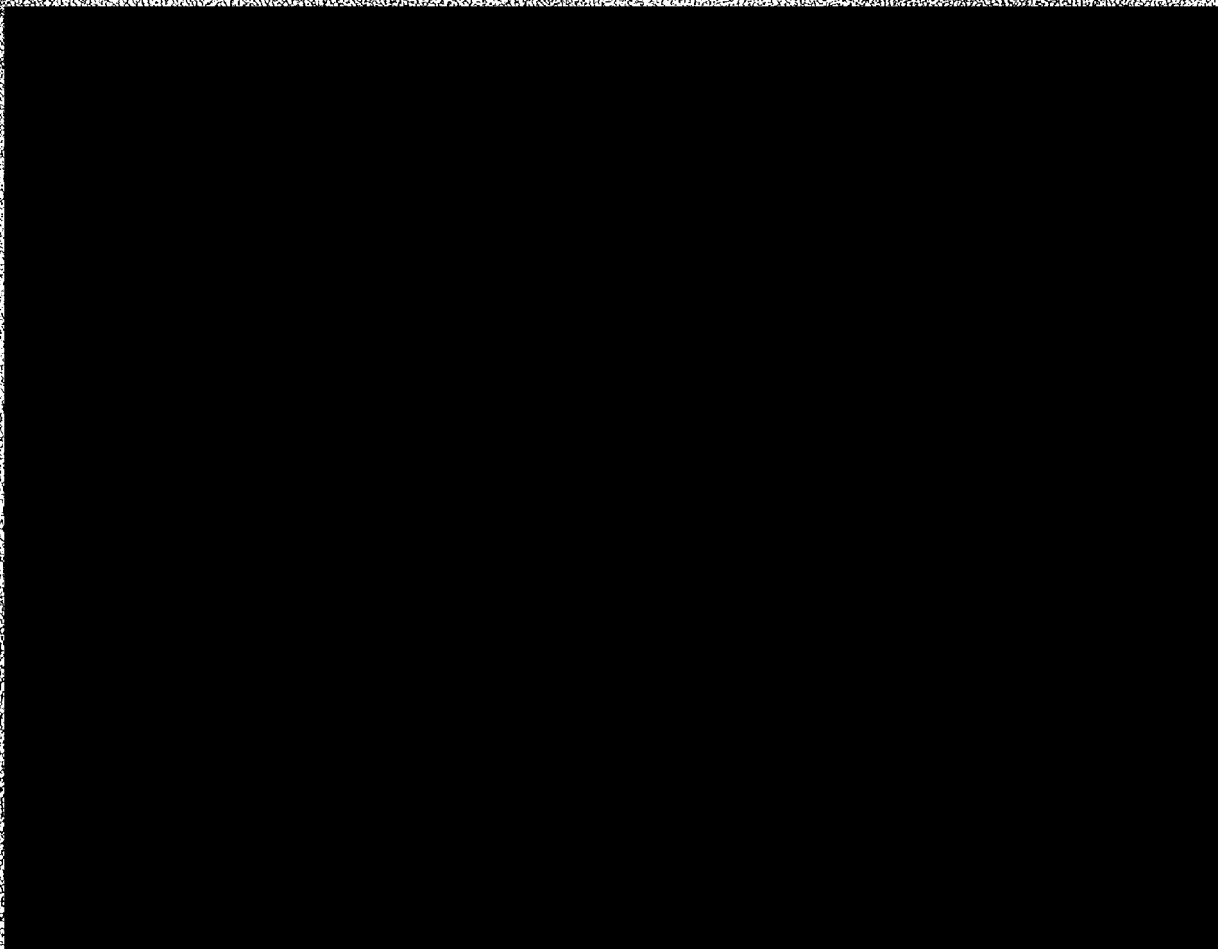

OPERATING MANUAL

AUTOMATIC 4" x 5" FILM PROCESSOR

By

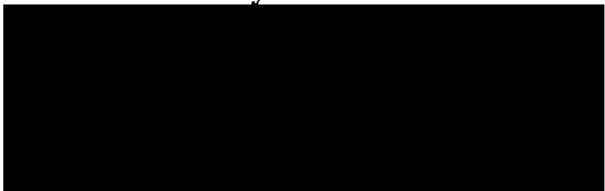

STATINTL

STATINTL

Approved For Release 2001/11/07 : CIA-RDP78B04747A000300010019-8

Approved For Release 2001/11/07 : CIA-RDP78B04747A000300010019-8

C O N T E N T S

1. Introduction
2. General Processor Design
3. Description
4. Installation
5. Set up and Adjustment
6. Tank Removal for Major Servicing
7. Operation of Output Magazine and Elevator
8. Speed and Immersion Times
9. Operation
10. Servicing and Maintenance
11. Electrical Components
12. Purchase Parts List
13. Diagrams and Schematics

INTRODUCTION

STATINTL

[REDACTED] Limited was formed in 1961 as a research, development and manufacturing company in photographic equipment and allied fields.

STATINTL

[REDACTED] Limited has developed for world-wide markets a number of new systems in film and paper handling. The patented SUPER LEVITRON principle, in which strip materials are transported and controlled by air and liquid cushions through non-touching guide channels, is one of these new concepts.

STATINTL

The [REDACTED] Automatic 4" x 5" Film Chip Processor utilizes a portion of this patented system.

GENERAL PROCESSOR DESIGN

The machine is designed to process black and white 4" x 5" film chips with a speed of 1 to 10 frames per minute in a continuous process sequence. The process section consists of five liquid steps and the drying chamber, all equipped with automatic temperature control.

The processor allows the utilization of various conventional chemical sequences. Two suggested forms are listed.

<u>Sequence "A"</u>	<u>Sequence "B"</u>
Developer Tank	Developer Tank
Stop Bath Tank	Stop Bath Tank
Fix Tank	Fix Tank
Hypo Eliminator Tank	First Wash
Wash Tank	Second Wash & Foto Flow
Dryer Chamber	Dryer Chamber

The use of the hypo eliminator is suggested to achieve the best possible archival quality in connection with relatively low water consumption, however some films with special drying characteristics are more satisfactorily processed by the "B" sequence.

The wash section is fed from a mixing valve supplying temperature controlled water. Tanks 1, 2, 3

and 4 are equipped with filtration units and heat exchangers.

For ease of operation main controls are conveniently located at the output end of the machine. The processor is designed for daylight operation and the loading of the processor is maintained by magazines which are darkroom loaded. Each magazine contains up to 36 transport slides which are used to carry the film chip through the process and drying sequences, after which the developed film and slides emerge and are stacked automatically in a take-out magazine.

By the use of phenolic resin laminates, the framework of the processor affords a corrosion resistant, but easy to maintain surface. In all other instances the machine consists of corrosion-proof material such as type 316 stainless steel, P.V.C., acrylic, delrin, etc.

For replenishment purposes tanks 1, 2, 3 and 4 have individual gravity flow meters. The required temperature in tanks 1, 2, 3 and 4 is maintained by an automatic temperature control unit. Removable access panels allow a thorough servicing of the machine.

The 4" x 5" Automatic Film Chip Processor is a complete self-contained unit and has been designed to provide maximum processing capabilities with a minimum of maintenance and operator skill.



DESCRIPTIONComponent Groups

Frame  
Tank Units  
Temperature Control  
Drying Unit  
Transport Mechanism  
Slide Injector  
Control Panel  
Magazine  
Take-out Magazine  
Film Chip Slide

FRAME

The two end members are constructed of phenolic resin wood laminate and are connected together by a top and bottom backbone of the same construction. A heavy stainless steel pipe spanning the end members carries the tank units on a stress free two point mounting. All support components are mounted on to this basic frame construction.

TANK UNITS

The tank units are constructed of P.V.C. and acrylic, heat welded for maximum strength. The use of clear acrylic allows an "on the spot" inspection of the cleanliness and function of each tank and assists in operation

and maintenance. Each tank has its own built-in overflow, circulation pump and plumbing for distribution of liquids to the SUPER LEVITRON plenums.

Tanks 4 and 5 are connected to temperature controlled wash water with flow control. The used wash water and all over-flow outlets drain into the P.V.C. drip tray.

Tanks 1, 2, 3 and 4 are equipped with a built-in heat exchanger and attached filtering system.

#### TEMPERATURE CONTROL UNIT

The temperature control unit consists of a stainless steel tank, electric immersion heaters and solenoid controlled cold water input and circulation pump. The systems operation is outlined in drawing No.11. It is important that the supply water at the location of the processor be at least 5 degrees below the chosen processing temperature.

#### DRYER UNIT

The design of the dryer unit is similar to that which is in the liquid section of the processor. The SUPER LEVITRON plenums are equipped with large loading entrances for temperature controlled pressurized air. The drying chamber and its duct work consists of a closed circuit with inlet and outlet for humidity control. Within this closed circuit electric heaters are installed to pro-

vide elevated temperatures when necessary. Thermostatic controls enable this temperature to be kept at plus or minus 2 degrees. The characteristic of the SUPER LEVITRON plenums design provides high air velocities without causing film flutter. This in turn allows for a high rate of moisture removal combined with slightly elevated temperatures.

#### TRANSPORT MECHANISM

The transport medium to guide the slides through the entire process sequence is provided by an endless mylar belt. The mylar belt has equally spaced carrier arms with which to support the slides, and guide rollers at appropriate locations link this belt throughout the entire film pass. Tension on this belt is adjusted by a movable roller. The belt is driven by an electric motor, the speed of which can be regulated to accommodate the proper requirements resulting from the time/temperature curves, emulsion and developer used.

#### SLIDE INJECTOR

The slide injector system consists of a hydraulic cylinder operated by water pressure. An overload bypass safety valve protects both magazine and slides from damage in case of misuse.

CONTROL PANEL

The control panel contains all the switch gear and controls necessary for the complete operation of the processor. Located on this panel is a light viewer for visual inspection of processed slides before their entrance into the take-out magazine.

MAGAZINE

The darkroom loading magazine has a capacity for up to 36 slides. The design of the magazine in combination with the design of the slide, provides such safeguards that the operator cannot load the magazine incorrectly.

TAKE-OUT MAGAZINE

The magazine to accommodate the processed slides as they are ejected from the dryer section of the processor is of formed aluminum, and provides the means of transporting and handling the film slides after processing.

FILM CHIP SLIDE

The slide is a ~~316 stainless steel~~ frame with clips into which the 4" x 5" film chip can be inserted. When inserted into the clips the film chip is locked into position. The design also provides two carrier hooks on the frame which engage with the belt carrier arms during the processing sequence.

INSTALLATION

Space requirements and service connection points for the installation of the Automatic 4 x 5 Film Chip Processor are shown on the installation drawing. The processor must be levelled by the use of levelling shims under the support feet.

Water requirements are dependent on condition of operation, however standard 1/2" Copper line feeds are adequate under normal circumstances. A wash water supply line from a mixing control valve plus a cold water line for heat exchanger system and injection cylinder are required. A 1 3/4" minimum floor drain should be used.

Air knife supply requires a maximum flow of 100 CFM at a static pressure of 1/2 PSI. This can be supplied by a small centrifugal blower or it can be connected to the main compressed air supply of the film laboratory.

Electrical requirements are 220 VAC, 60 cycle split single phase, fused at 40 amperes. Air conditioning of the processing area is recommended, if possible, to assure controlled temperature and humidity for optimum environmental operation.

SET UP AND ADJUSTMENT

With reference to section "Operation" pages 16, 17 and 18, the following guide will assist in proper processor operation.

Loaded film chip slide holders are inserted into the magazine with the supplied magazine loader. The operation of this accessory is self evident as the slide, magazine and loader are safety interlocked to prevent error during insertion of slides.

NOTE

To prevent malfunctioning  
DO NOT distort chip slide  
holder.

The loaded magazine can be inserted into the processor in only one way due to the offset locating pins. The magazine must be locked into position by turning the magazine locking lever to the left. This lever operates a series switch connected with the injector switch located on the control panel. When both switches have been closed the delay relay is energized and three minutes later the hydraulic injector begins to cycle and inject slides into the processor.

The purpose of this delay is to ensure a minimum 3 minute spacing between the injection of sets of slides from the loaded input magazines into the processor. This in turn provides 3 minute intervals between the time the take out magazine reaches a full condition and the start of a new set of processed slides being ejected from the machine into the next take out magazine. Adequate time is thus provided for exchanging take out magazines.

The timing of the hydraulic injector is critical and is factory set. If for any reason it is desired to alter the timing it can be adjusted by carefully moving the timing cam of micro switch MS5 (Refer drawing No.3). The injector power stroke can be adjusted to provide only the drive force necessary to inject the film slide into the machine. It is recommended that prior to initial operation of the processor, the injector safety valve (reference drawing No. 3) be backed off fully and the operator, by inserting his hand into the magazine mounting opening on the top of the processor, can check the line force. The injector should be activated while the operator retards the moving injector ram. As his assistant slowly closes the safety valve the operator can determine when sufficient force is being exerted to inject a slide from a fully loaded magazine into the processor.

NOTE

During this adjustment the heat exchanger solenoid valve must be in the open position (set liquid thermostat to cooling position and turn liquid temperature control on).

The injector supply line has been equipped with a filter unit to prevent any foreign matter from entering the hydraulic cylinder and causing possible damage. This filter should be replaced as required, the period of time depending on existing water conditions.

The transport belt is sprocket driven by a DC controlled motor. To eliminate the possibility of machine damage by possible jamming of the transport belt by any means, a slip clutch has been provided on the motor driven output shaft. This clutch has been factory set and should require no further adjustment (Reference drawing No. 3).

The transport belt tension should be sufficient to guarantee non-skip of the sprocket rollers. The tension is factory set but can be adjusted to compensate for change by moving the tension adjust roller as located on drawing No. 4.

The timing of the viewer stop solenoid is pre-set. If accidentally changed the timing can be adjusted by careful movement of the micro switch MSl timing cam.

During initial testing of films, use of the dryer baffle (Reference drawing No. 4) can prove to be beneficial. The baffle provides a slow rate drying path which normalizes the film prior to entrance into the high rate SUPER LEVITRON drying plenums. This baffle plus the utilization of the Type "B" chemical sequence, as outlined on page No. 3, results in optimum drying for films with hard drying characteristics. The baffle can be easily inserted into the holding brackets in the position indicated on drawing number 4.



TANK REMOVAL FOR MAJOR SERVICING

The removal of a process tank can be accomplished by carefully positioning the belt break-apart points in their proper register. The break points are located at two stations on the transport belt, and can be recognized by the belt overlap at the transport bar mounting screws.

Position one set of break points to the left of the tank to be removed and one set of break points to the right of the tank. Completely disconnect the belt tension roller assembly and allow the belt to slacken. Carefully remove the two screws on the right hand break points and affix the tank side of the disconnected belt to the tank to be removed. Connect the other belt end to the processor by using a small wire or bonding tape. Repeat belt disconnect procedure at left break point.

CAUTION

If developer tank is removed the slide support bars must be positioned on the slide holding cam wheel in the position removed. Slide pickup will not operate properly if transport belt and delrin holding cams are not synchronized.

Disconnect pump plumbing, heat exchanger, water connections, thermostat, etc. from rear of tank. Remove tank mounting bolts from top rear of tank.

Pull tank forward, rotating base of tank on support beam. Lift tank free of processor.

Reinstall in reverse order.

OPERATION OF OUTPUT MAGAZINE AND ELEVATOR

When chip is dropped into chute, slide is stopped momentarily for viewing by a solenoid operated stop lever.

Stop lever opens and slide drops into output magazine, activating a micro switch that energizes spindle motor.

Motor makes one revolution and is stopped by a micro switch trip. This action repeats until 36 slides are collected in output magazine (full).

When slide platform is down, a bell rings until output magazine is exchanged and elevator "up" button is pushed.

NOTE

Insert new output magazine before pushing "up" button.

Elevator rises to limit switch, stops spindle and releases system to normal timing.

If output magazine is not full, push elevator over-ride down button to bring elevator down. Buzzer signal indicates that elevator is down and output magazine can be exchanged.

SPEED AND IMMERSION TIMES

<u>Chips per minute</u>	<u>Developing time</u>
1 chip	15 min. 12 sec.
2 chips	7 min. 38 sec.
3 chips	5 min. 6 sec.
4 chips	3 min. 49 sec.
5 chips	3 min. 1 sec.
6 chips	2 min. 33 sec.
7 chips	2 min. 11 sec.
8 chips	1 min. 54 sec.
9 chips	1 min. 42 sec.
10 chips	1 min. 32 sec.

CAPACITIES

<u>Tank</u>	<u>Liquid</u>	<u>Film Path</u>
1	18½ U.S.gal.	140 inches
2	8½ " "	76 "
3	17 " "	135 "
4	8½ " "	76 "
5	17 " "	135 "

OPERATION

The operating sequence should be followed as indicated. This sequence is to be used after initial set-up and test has been performed to determine the proper film-chemical relationship for best results.

- (1) Open front door cover. Fill tanks with proper chemical.
- (2) Switch on main power.
- (3) Push temperature control button located on temperature control unit behind developer tank. Fill heat exchanger until it overflows. Adjust flow valve on feed line to minimum requirement to maintain set temperature.

CAUTION

Fill heat exchanger tank before operating heat exchanger pumps. Pump seal damage will result when run dry.

- (4) Start circulation pumps and heat exchanger pump to bring temperature up to desired process temperature. For high processing temperature use 2nd boost heater. Switch is located on temperature control unit. For normal processing temperature use single heater.

CAUTION

Do not run pumps dry as pump seal damage will result.

- (5) Allow process liquid to reach operating temperature.
- (6) Regulate wash water temperature to process temperature and fill wash tank.
- (7) Start dryer blower and bring dryer temperature up to proper temperature.
- (8) Select transport speed and start transport mechanism.
- (9) Turn injector switch on and check for correct operation (red light indicating push position). Ensure magazine interlock switch is in "on" position.

NOTE

The built-in time device will prevent injector operation for 3 minutes.

- (10) Turn off injector power and magazine interlock switch.
- (11) Place loaded magazine in processor.
- (12) Lock magazine in position by turning lever in front of magazine ramp from right to left. (To remove magazine turn lever back to "off" position).

NOTE

The above operation closes electrical circuit for injector. If magazine is not locked, injector will not operate.

- (13) Place new slide collector in elevator and push "Elevator Up" button.
- (14) Turn replenishment system on if required.
- (15) Close front cover door.
- (16) Start blower unit for air knife.
- (17) Turn injector switch on.
- (18) The machine will now automatically process all slides contained in the magazine.

SERVICING AND MAINTENANCEPUMPS:

A periodic check of pump housings is advisable.  
Check for leaks from diaphragm seal.

AIR BLOWER:

The air filter should be inspected and replaced with an  $8\frac{3}{4}$ " x  $5\frac{1}{2}$ " x 1" filter of suitable value when required.

LIQUID FILTERS:

Filter cartridges must be replaced periodically, to ensure cleanliness of process solutions.

To replace filter cartridges, close input and output valves. Unscrew shell to your left, withdraw cartridge and replace with new one.

Do not over tighten filter shell.

TANKS AND INSERTS:

For cleaning use normal commercial tank cleaner.

TRANSPORT SYSTEM:

Check clutch on drive motor to ensure non-slip operation. Drive pins in pulleys must index with the perforated mylar belt.

Carrier arms must be straight and not distorted.  
Oil level in drive motor gearhead should be checked every 2 months.

PICK-UP STATION IN DEVELOPER TANK:

Timing on slide release cams should be visually inspected for proper operation, in case of transport belt slippage.

INJECTOR:

Check for leaks on injector and supply lines.

Packing gland on hydraulic cylinder is standard item and can be easily replaced if damaged.

(See instruction on enclosed bulletin).

ELEVATOR:

Check micro switches periodically for proper operation. Elevator motor gearhead should be repacked annually.

ELECTRIC MOTORS:

All electric motors have pre-lubricated bearings and require no further servicing.



42-09-000 ELECTRICAL COMPONENTS

Item	Part #	Part	Description	STATINTL
1	S1	Heat Exchanger	[REDACTED] 15A, 125v Toggle 7560 K5	STATINTL
2	S2	Fill, Temperature Control Unit	[REDACTED] #2340 Push Button	STATINTL
3	S3	Boost (Liquid)	[REDACTED] 15A, 125v Toggle 7560 K5	STATINTL
4	S4	Injector	[REDACTED] 15A, 125v Toggle 7560 K5	STATINTL
5	S5	Pump	[REDACTED] 15A, 125v Toggle 7560 K5	STATINTL
6	S6	Main Power	[REDACTED] 15A, 125v Toggle 7560 K5	STATINTL
7	S7	Viewer	[REDACTED] #2340 Push Button	STATINTL
8	S8	Elevator "Up"	[REDACTED] #2340 Push Button	STATINTL
9	S9	Elevator "Down"	[REDACTED] #2340 Push Button	STATINTL
10	S10	Transport	[REDACTED] 15A, 125v Toggle 7560 K5	STATINTL
11	S11	Dryer Stop	Push Button N.C.	STATINTL
12	S12	Dryer Start	[REDACTED] Push Button N.O.	STATINTL
13	S13	Boost (Air)	[REDACTED] 15A, 125v Toggle	STATINTL
14	MS1		Micro Switch V3-9001 2-63 [REDACTED]	STATINTL
15	MS2		Micro Switch V3-9001 2-63 [REDACTED]	STATINTL
16	MS3		Micro Switch V3-9001 2-63 [REDACTED]	STATINTL

Item	Part #	Part	Description
17	MS4		Micro Switch V3-9001 2-63 [REDACTED] STATINTL
18	MS5	Cam operated	Micro Switch V3-9001 2-63 [REDACTED] STATINTL
19	MS6	Limit reverse	Micro Switch V3-9001 2-63 [REDACTED] STATINTL
20	MS7	Return stop	Micro Switch V3-9001 2-63 [REDACTED] STATINTL
21	MS8		Micro Switch V3-9001 2-63 [REDACTED] STATINTL
22	MS9		Micro Switch V3-9001 2-63 [REDACTED] STATINTL
23	MS10	Air Flow	Mod. 2A, rating 5 amp. at 250 V.A.C. [REDACTED] STATINTL
24	MS11	Return safety	Micro Switch V3-9001 2-63 [REDACTED] STATINTL
25	SL1	"In" solenoid valve	} Asco Midget Valve #8314104 115/60 orifice 1/8" dia. [REDACTED]
26	SL2	"Out" solenoid valve	
27	SL3	Cold water solenoid valve	} #K27AA 622, Ser. B3KC orifice 3/16 dia. [REDACTED] STATINTL
28	SL4	Solenoid	} 16 - Cont. - 115 V.A.C./60 cy. [REDACTED] STATINTL
29	K1	Relay	MKH3A, 115 VAC, "Line"
30	K2	Relay	MKH3A, 115 VAC, "Line"
31	K3	Time delay relay	Amperite 115 NO 180
32	K4	Relay	MKH 3A, 115 VAC "Line"
33	K5	Injector relay	MKH 3A, 115 VAC "Line" STATINTL
34	K6	Dryer Contactor	} #41 NA 30 AF-A [REDACTED]
35	K7	Pump Contactor	

Item	Part #	Part	Description	STATINTL
36	K8	Main Contactor	702 Series K Size 0 3 Pole 600 VAC 18 amp.	STATINTL
37	K9	Relay	KRP 11 AG, 115v, 10 amp., 50/60 cy	
38	K10	Starting relay	#91252 - 143	STATINTL
39	T1	Transformer	Type 167 C 60, Primary 115v/60 cy.	
40		Thermistor Dev. Tank	Fenwal 8-64/71711-31 Range: 25-250°F	STATINTL
41		Temperature Controller	Fenwal #53615-0 Mod. 98-B	
42	F1	Fuse	30A, 250v, Slow Blow	
43	F2	Fuse	30A, 250v, Slow Blow	
44	F3	Fuse	3A, 125v	
45	F4	Fuse	3A, 125v	
46	F5	Fuse	15A, 250v, Slow Blow	
47	F6	Fuse	30A, 250v, Slow Blow	
48	F7	Fuse	3A, 125v	
49	F8	Fuse	20A, 125v	
50	F9	Fuse	2A, 125v	
51	F10	Fuse	15A, 125v	
52	F11	Fuse	5A, 125v, Slow Blow	
53	F12	Fuse	Buss MDL 2 - 125v	
54	F13	Fuse	Buss MDL 2 - 125v	STATINTL
55	R1	2 off Heater	Immersion Heater 115 volt/750W SX75 6IA-3004	
56	R2	4 off Heater	Cone Heater 115 volt/660W	
57	M1	Elevator motor	Bodine type NC1-12R, 1725 R.P.M. 115 volt A-C .26 amp., 1/70 H.P.	
58	C1	Condensor	Reducer: Torque 7.1 Ratio 36:1 48 R.P.M.	

Item	Part #	Part	Description	STATINTL
59	M2	Transport Motor	Ratiotrol R12 = Motor: 1/12 H.P. [REDACTED] DC AASD 1725 RPM Model 5 BN 68Y shunt wound A2 Reductor: UF109-10, ratio 40:1	
60	M3	Dryer motor	Type RKJ Frame 56 #FF7711N 3450 RPM - 1 1/2 H.P. 230V 7.6 F.L. amp. [REDACTED]	STATINTL
61	M4	Temperature Control Pump Motor	Frame J330- 1/8 H.P. 115v 50/60 cy. 2.2/3.0 amp. 2850/3450 R.P.M. [REDACTED] Pump #2824	STATINTL
62	M5	6 off Liquid Pump Motors	C1446 - 1/3 H.P. 230v. Y-Type 50/60 cy. 2850/3450 2.4/2.9 amp. - 50°C contin. [REDACTED]	STATINTL
63	M6	Ventilator Blower	Electrohome #2818-41-05-23 Fan duty 115 volt/60 cy. .5 amp 1550 RPM	STATINTL
64		Adjust. Thermostat (Dryer section)	Temp. range - 100 to +400°F 12-62 #17010-0 [REDACTED]	
65	BUZ	Buzzer	Standard 6 volt buzzer	
66		Viewer lamp	F.G. 10 - 48A 25 watt 120 volt [REDACTED]	STATINTL
67	KA5 DAF	Rectifier	Klip-Sel made by [REDACTED]	STATINTL
68		Power supply	4 off Diodes #10 B4 4 off Diodes #5D94 [REDACTED]	STATINTL
69		11 off Pilot lamps	amp. APL 125v [REDACTED]	STATINTL
70		Overheat safety	Thermostat SA-501 Model B200 [REDACTED]	STATINTL

PURCHASED PARTS LIST

Item	Part #	Description	STATINTL
1	2/4	Dryer Air Intake Filter	[REDACTED]
2	2/10	Flowmeter	Mod. 10A 3135V
3	3/12	Filter Cartridge	Cuno Micro Klean #2230 F1, 25 Mikron STATINTL
4	3/15	Valves	PVC Ball Valve 3/4" [REDACTED]
5	3/16	Filter Cartridge	[REDACTED] Cartridge Kit RG 2 AHL - 051 1/2" dia. [REDACTED]
6	4/19	Valve	Crane cat. #218L STATINTL STATINTL

LEGEND

Front View - Closed Machine

1. Removable front door
2. Service panel mounting screws
3. Slide indicator - output magazine
4. Output magazine
5. Service panel
6. Inspection light push button
7. Control panel
8. Inspection viewer
9. Inspection light box
10. Dryer air exhaust
11. Magazine injector safety interlock

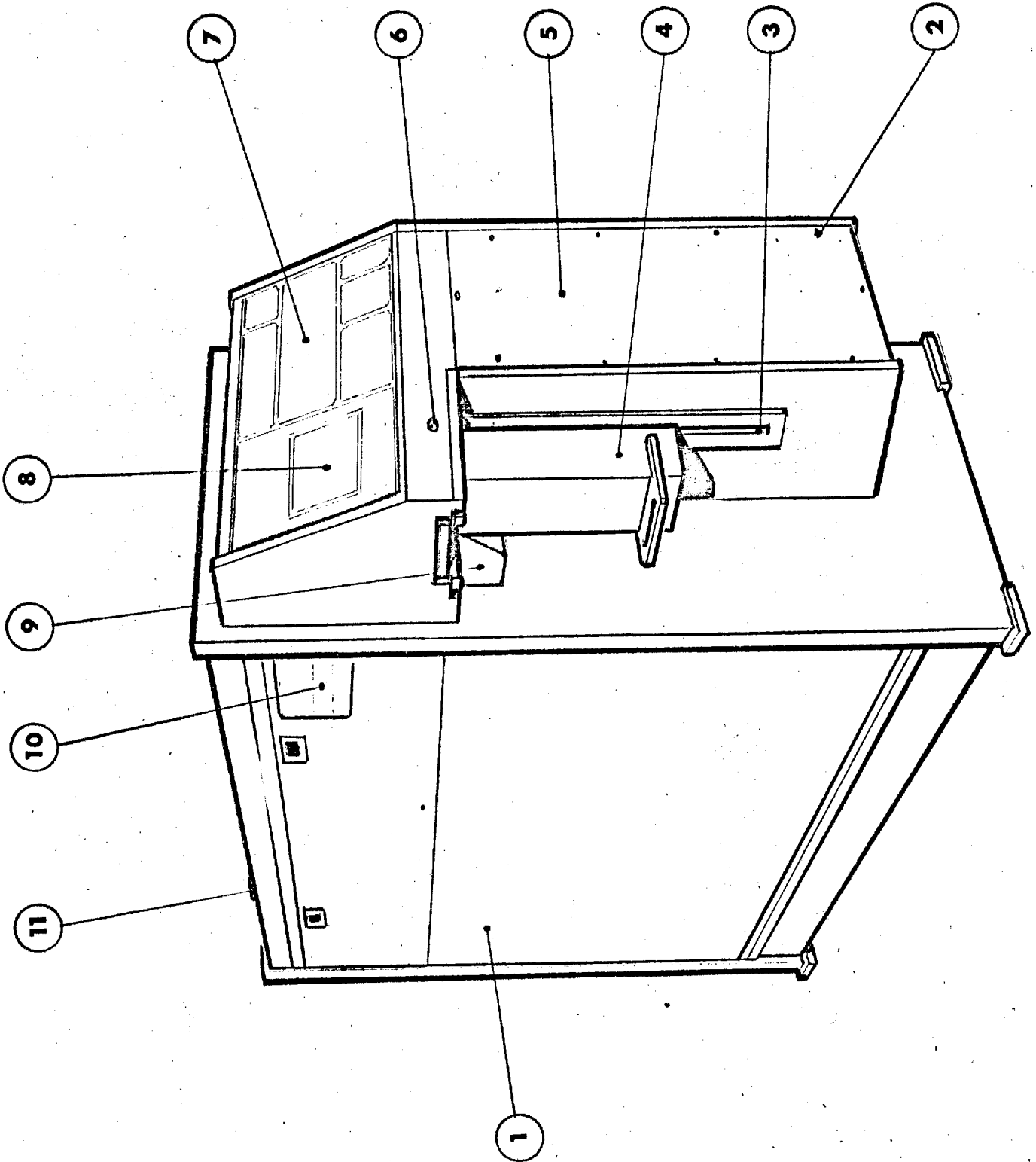

FRONT VIEW - CLOSED MACHINE

LEGEND

Back View - Closed Machine

1. Control console cooling vent
2. Control console
3. Fresh air intake - pump motor section
4. Dryer air intake filter
5. Drip tray drain
6. Injector and temperature control unit supply line
7. Wash water supply line
8. Removable back door
9. Exhaust ventilator - pump motor section
10. Replenish controls
11. Input magazine
12. Rear service panel mounting screws
13. Service panel



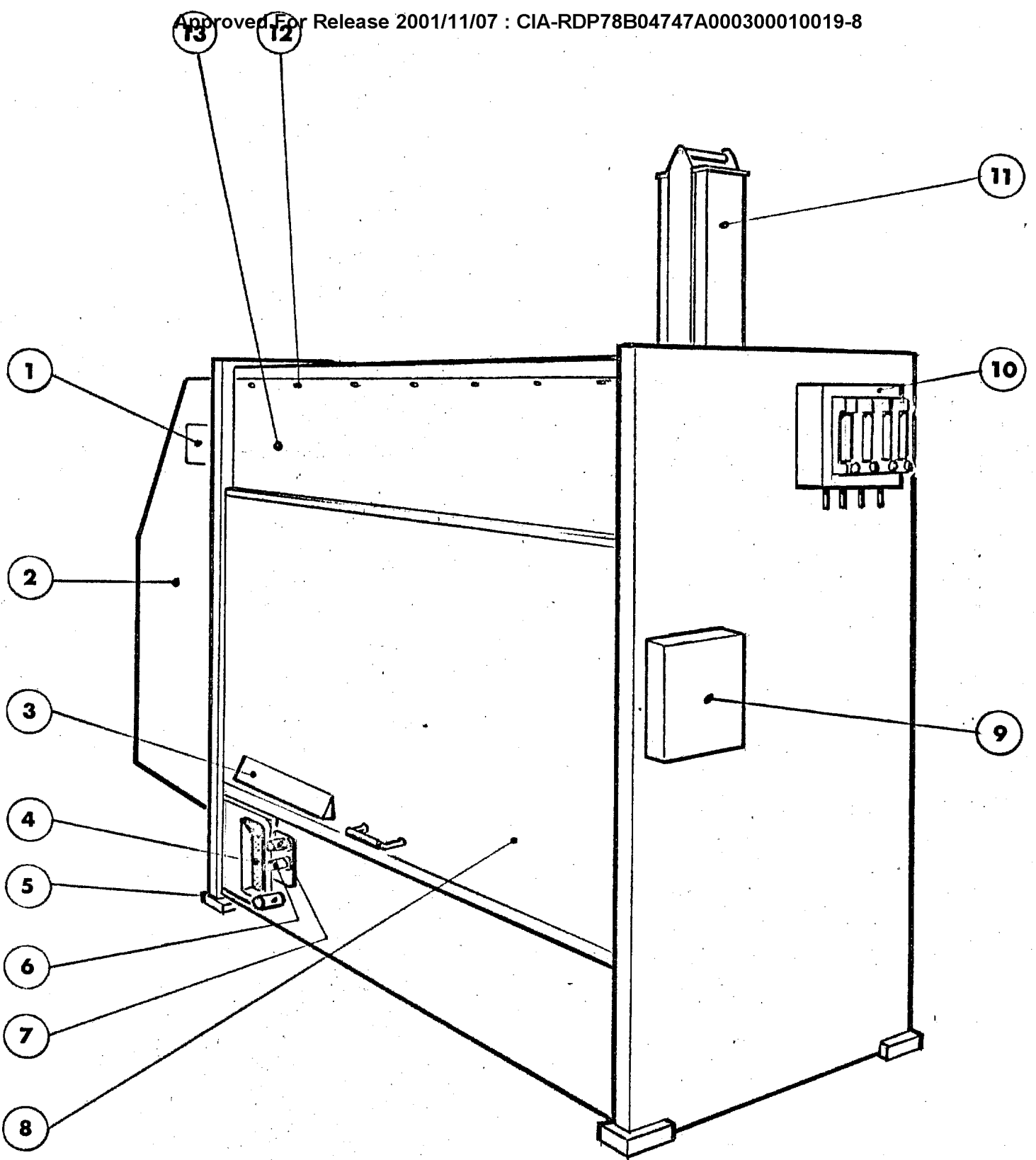

**BACK VIEW - CLOSED MACHINE**

LEGEND

Back View - Open Machine

1. Main power "input"
2. Fuse block
3. Main contactor No. K8
4. Neutral and ground tie point
5. Pump contactor No. K7
6. Dryer contactor No. K6
7. Wash water adjustment valve - Tank No. 4 or 5
8. Wash water adjustment valve - Tank No. 5
9. Circulation pumps
10. Temperature controlled wash water line
11. Injector and temperature control unit supply line
12. Water filter
13. Pump intakes
14. Heat exchanger pipe
15. Filter isolation valves
16. Filters
17. Water exhaust pipe
18. Thermostat developer tank
19. Circulation Pump-Temperature Control Unit
20. Temperature control unit
21. Filler switch
22. Boost heater switch
23. Inspection lid
24. Adjustment valve - cold water input
25. Safety clutch for film transport belt
26. Drive motor
27. Injector solenoid valve "out"
28. Injector solenoid valve "in"
29. Injector spring loaded safety valve
30. Feed solenoid for temperature control unit
31. Rear door main catch
32. Injector "out" supply line
33. Micro switch No. MS1 and No. MS5
34. Injector "in" supply line
35. Injector and viewer stop cam
36. Relay No.K4
37. Relay No.K5
38. Time delay Relay No. K3
39. Air Knife Air supply connection pipe

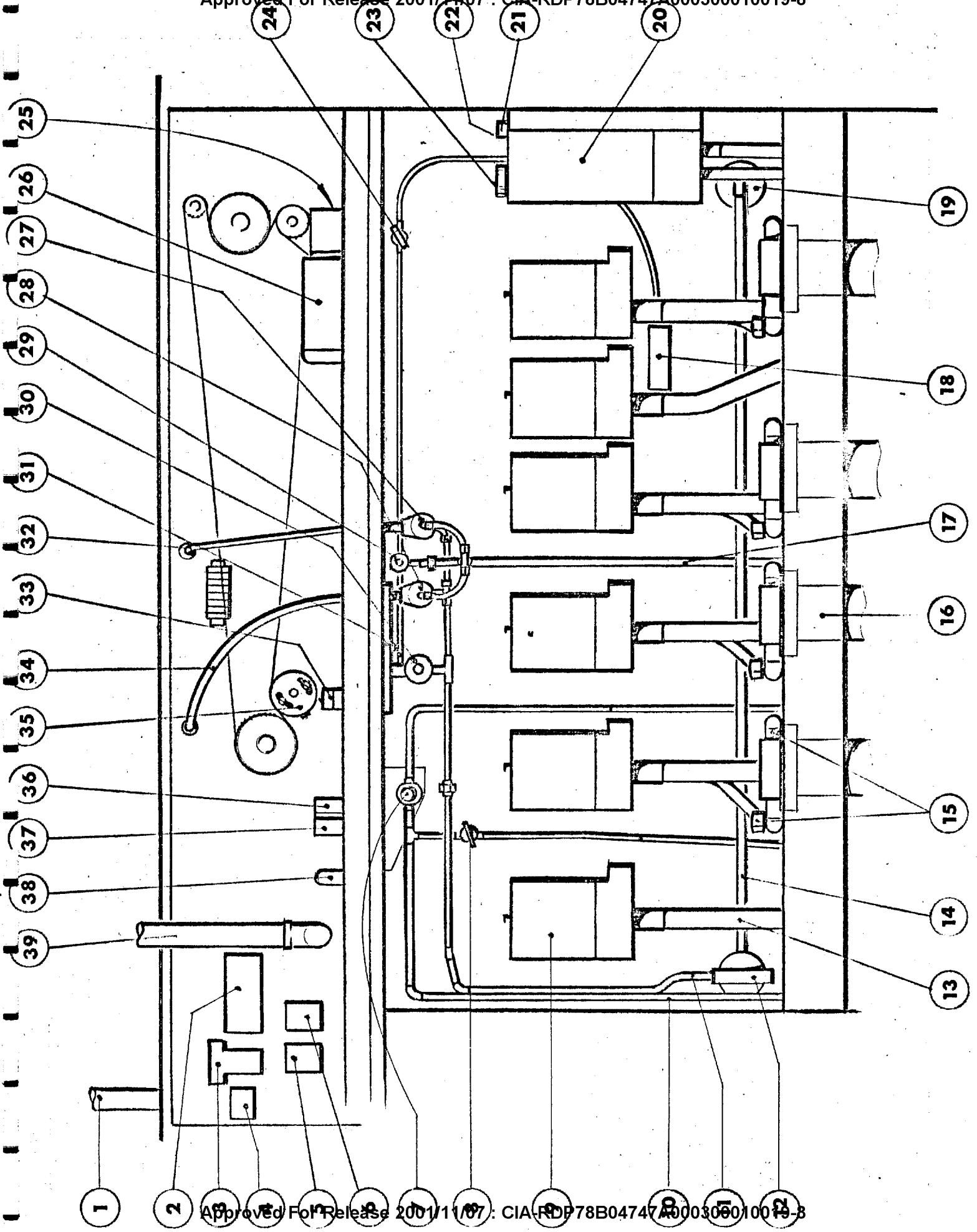

LEGEND

Front View - Open Machine

1. Pick-up guide
2. Temperature control unit
3. Circulation Pump - temperature control
4. Heat exchanger plates
5. Front overflow
6. Transport idler pulleys
7. Liquid plenums
8. Air return to dryer blower
9. Elevator drive assembly
10. Air plenums
11. Lower light seal wall
12. Elevator spindle
13. Elevator
14. Transport belt tension adjustment
15. Transport belt
16. Air knife
17. Light seal - transport belt
18. Upper light seal
19. Wash tank overflow - adjustment valve
20. Injector
21. Micro switch 6, 7, 11
22. Injector supply "in" connection
23. Injector supply "out" connection
24. Magazine Injector safety interlock
25. Slide input chute
26. Transport drive pulleys
27. "Slow dry" baffle

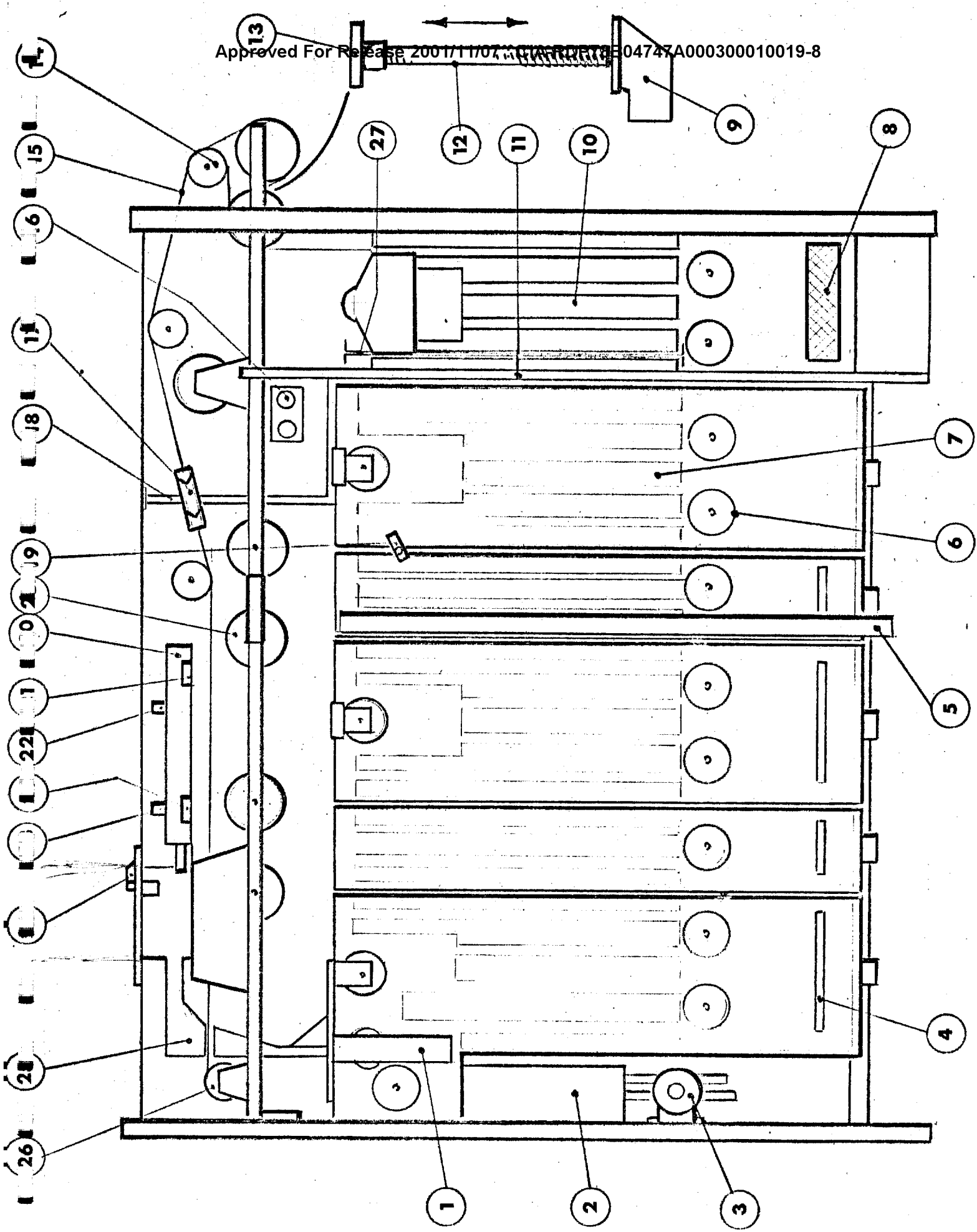

FRONT VIEW - OPEN MACHINE

Draw. No. 4

LEGEND

Control Console

1. Elevator trip micro switch MS9
2. Inspection light push button
3. Inspection light
4. Limit micro switch MS3
5. Single revolution micro switch MS2
6. Spindle drive motor M1
7. Relays - K1, K2 and K9
8. Transformer - T1
9. Buzzer
10. Blower motor - M3
11. Liquid temperature controller unit
12. Elevator assembly
13. Control panel
14. Limit micro switch MS4
15. Viewer stop solenoid SL4
16. Inspection viewer

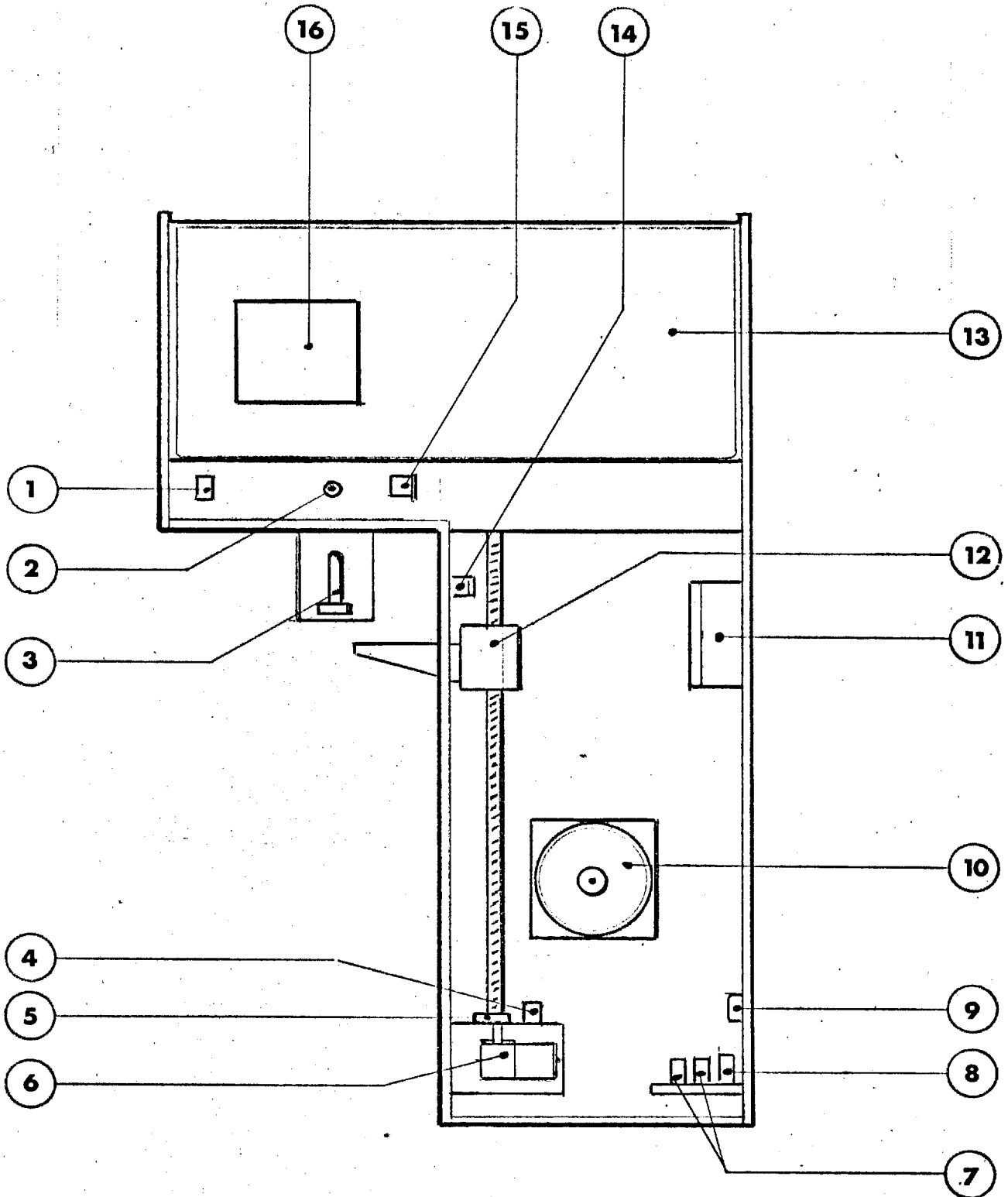

# CONTROL - CONSOLE

LEGEND

Bottom View Magazine

1. Magazine body
2. Magazine block
3. Light seal trip-lifting levers
4. Slide exit light seal trip opening
5. Slots for slide lifting levers
6. Slide entrance light seal trip opening
7. Feed-in slot
8. Locating pins
9. Magazine lock hole



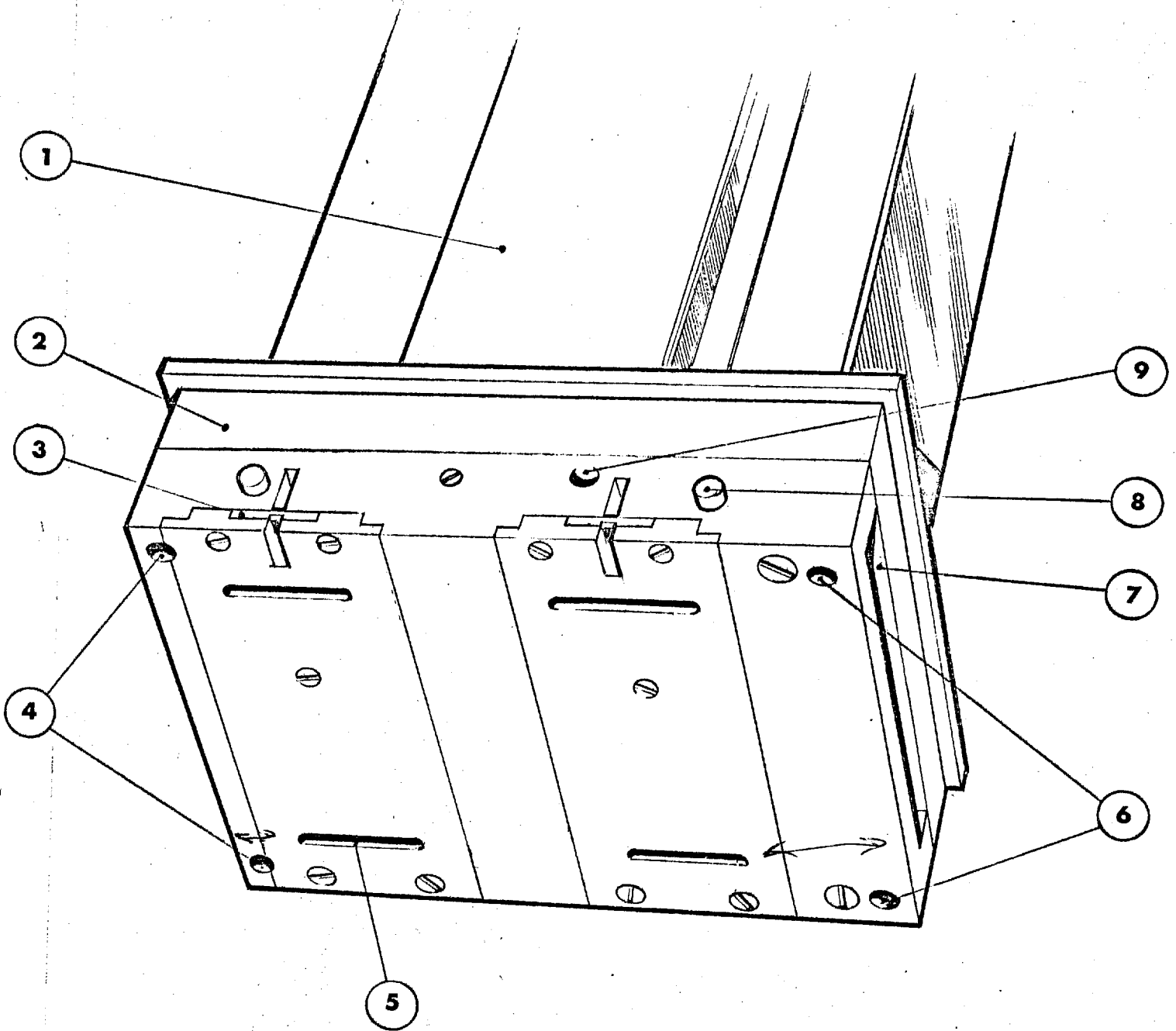

**BOTTOM VIEW - SIDE MAGAZINE**

LEGEND

Film Chip Slide Holder

1. Slide frame
2. Bottom lock guide
3. Edge guides
4. Top guide
5. Slide transfer surface
6. Transport hooks

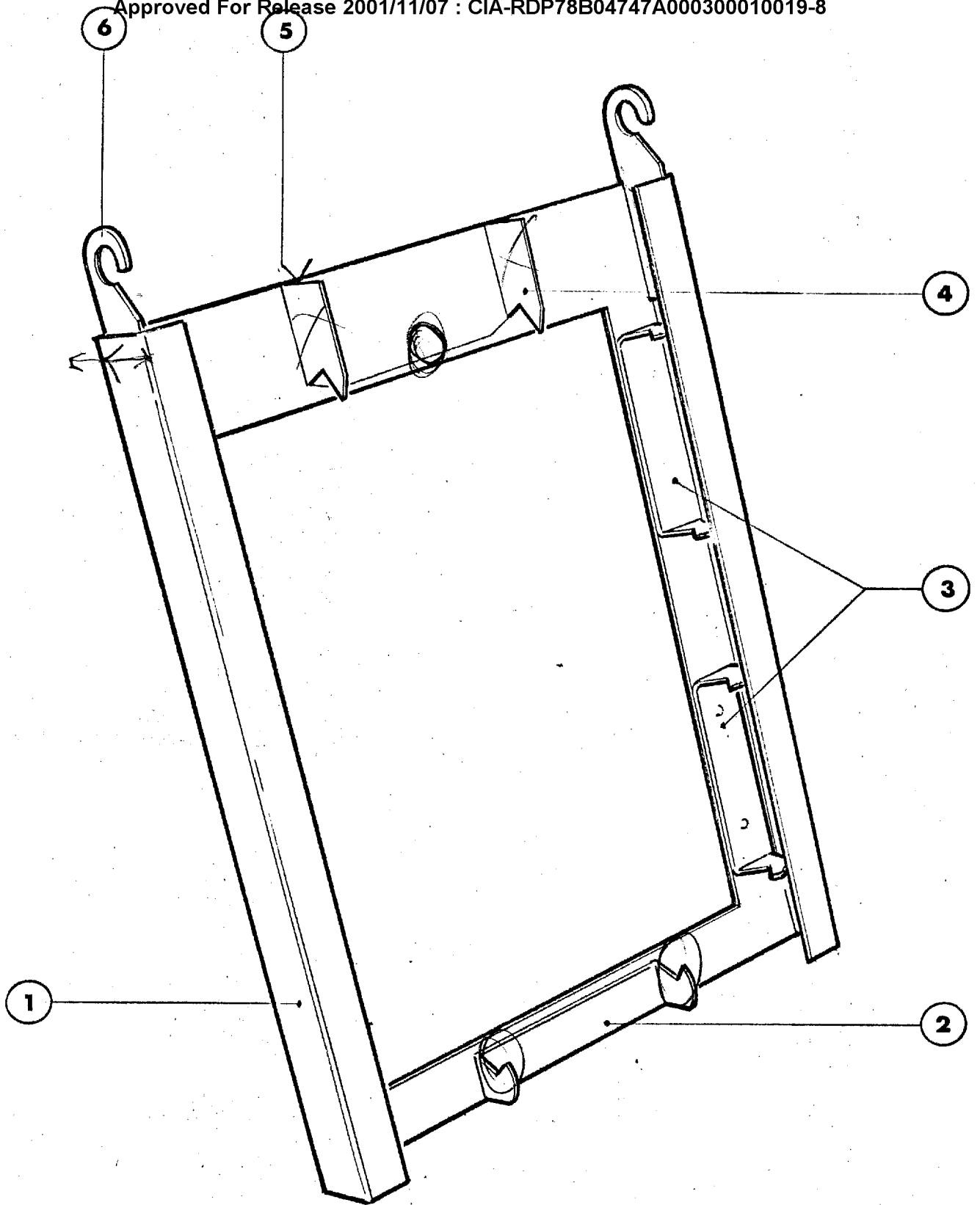

**4x5" FILM CHIP-SLIDE HOLDER**

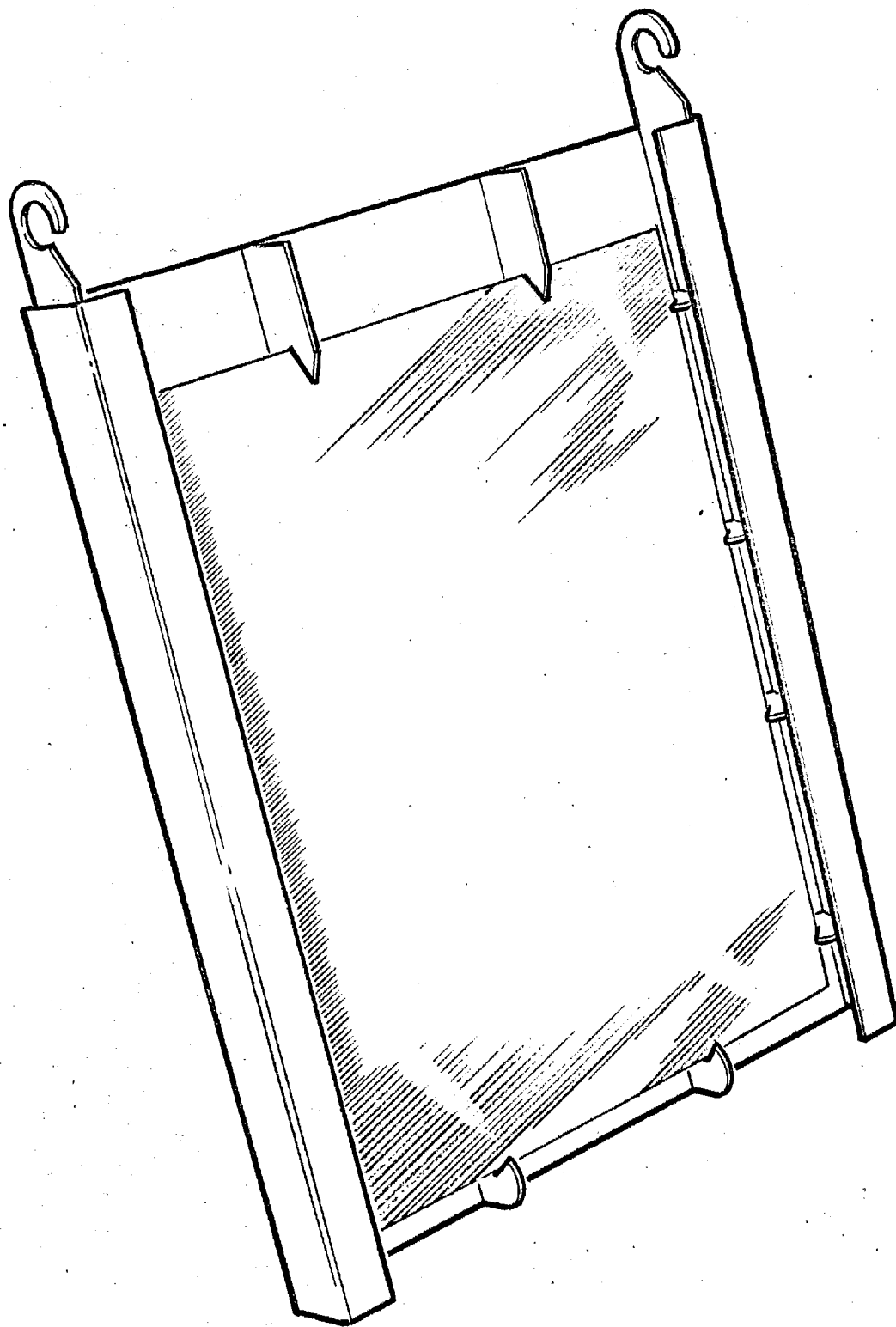

**4" x 5" FILM CHIP-SLIDE HOLDER WITH FILM**

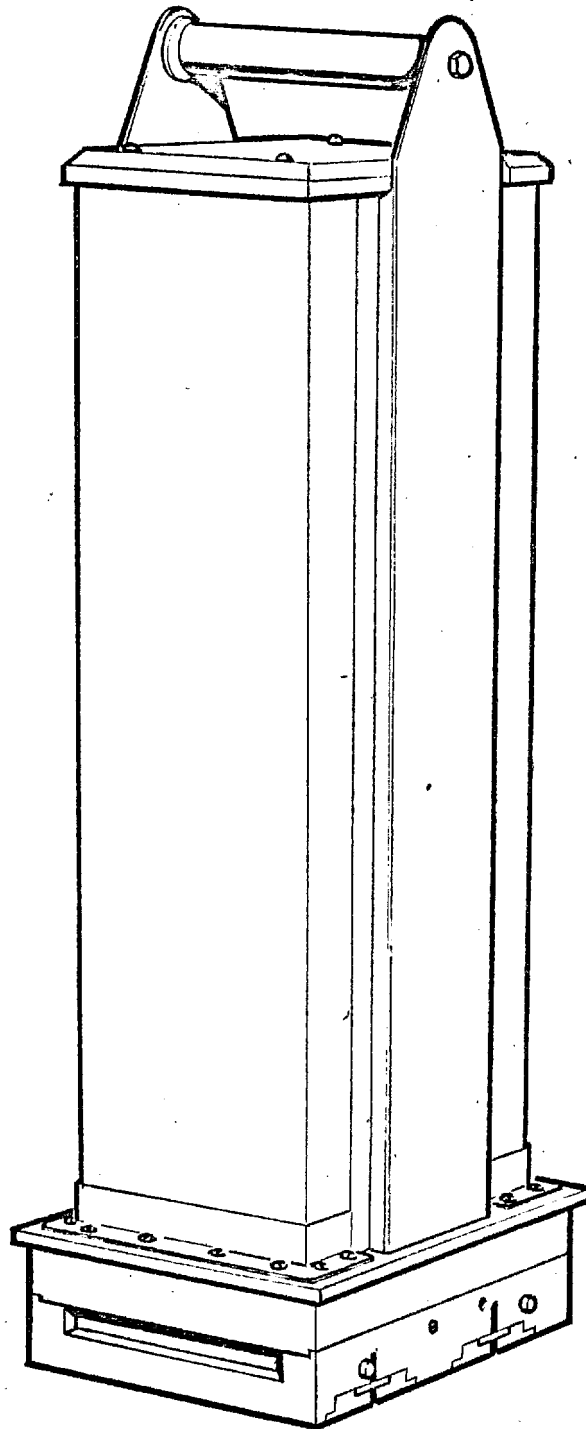

**MAGAZINE - AUTOMATIC 4"x5" FILM PROCESSOR**

STATINTL

Approved For Release 2001/11/07 : CIA-RDP78B04747A000300010019-8

Approved For Release 2001/11/07 : CIA-RDP78B04747A000300010019-8

LEGEND

Temperature Control Unit

1. Cold water solenoid valve
2. Cold water feed line
3. Process tank
4. Heat exchanger plates
5. Supply line
6. Return line
7. Overflow
8. Heater box
9. Inspection cap
10. "Fill" push button switch
11. Boost Heater Switch
12. Boost Pilot Light
13. Circulation pump motor fuse
14. Heater fuse
15. Electrical connection
16. Flow adjustment valve
17. Motor starting relay K10 and Terminal Box
18. Circulation pump
19. Tank thermostat

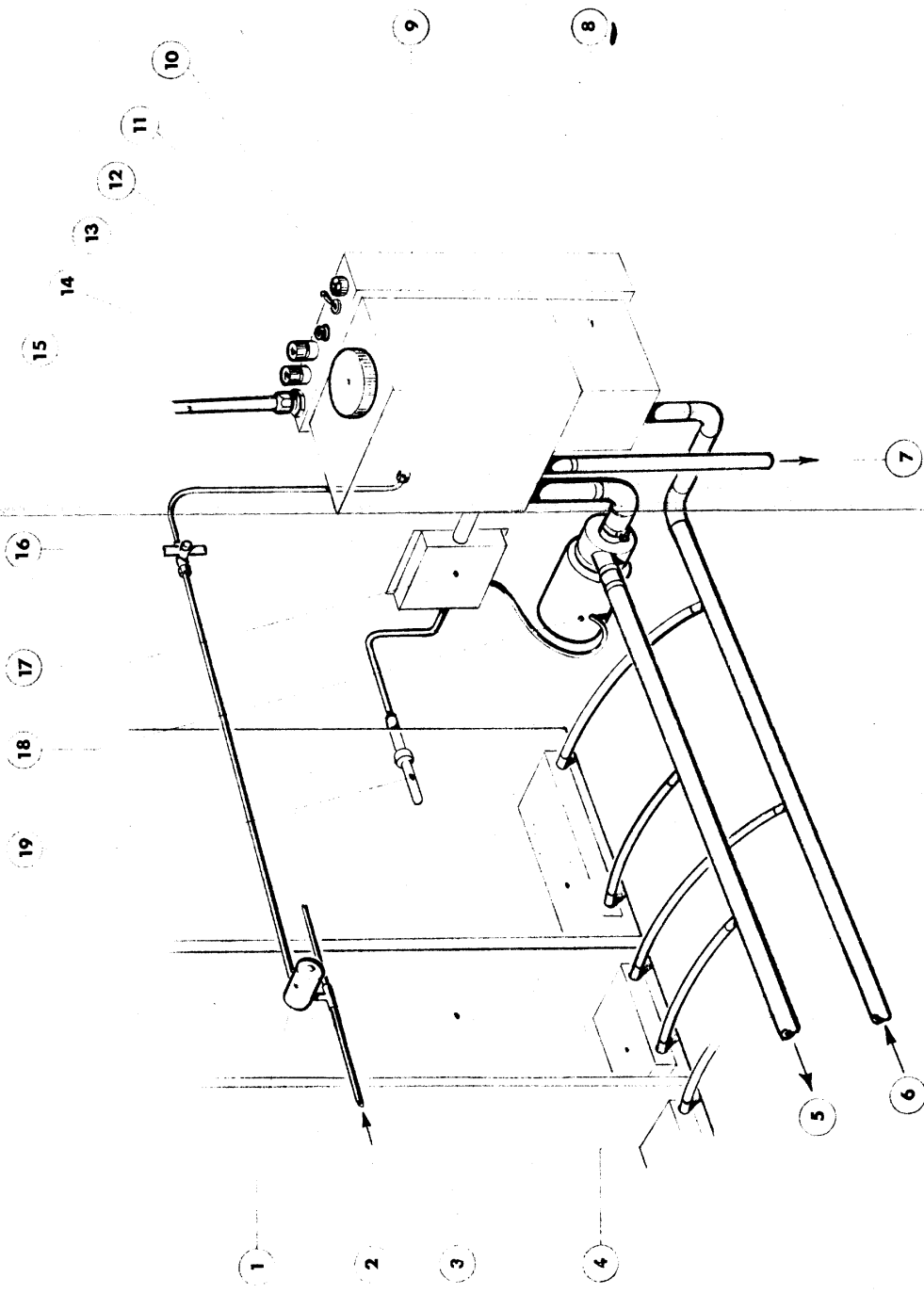

TEMPERATURE CONTROL UNIT



LEGEND

Sequence "A"

1. Number 4 replenishment line - Feeding hypo clearing to No. 4 tank
2. Wash water flow valve - To adjust wash water flow in No. 5 tank
3. Wash water feed line
4. Back view wash water flow valve
5. Wash water metering valve - closed position
6. Wash water connection tubes. Connect to No. 5 tank
7. Wash water inlet. This opening must be plugged.

TANK 4 & 5 PLUMBING CONNECTIONS FOR PROCESS SEQUENCE 'A'

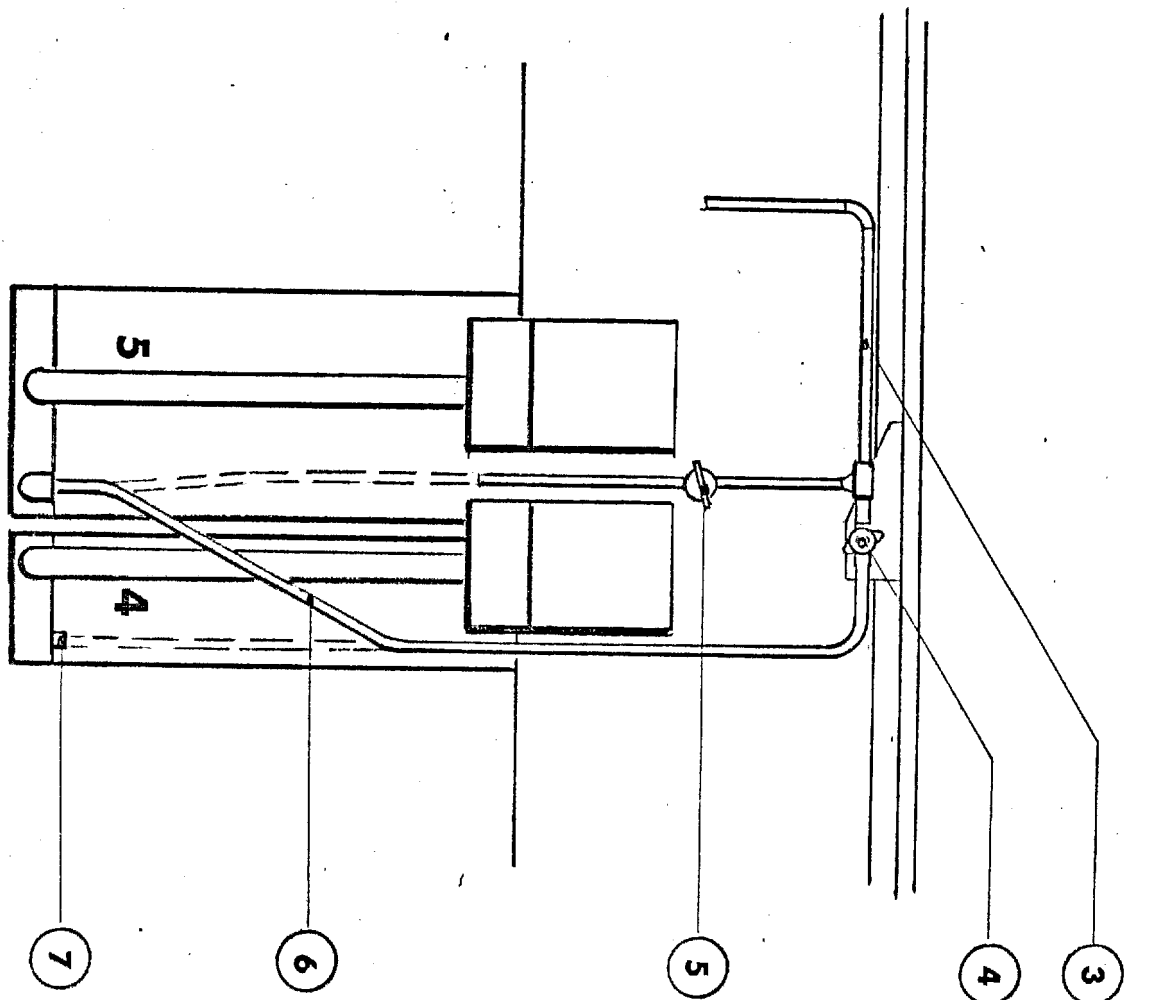
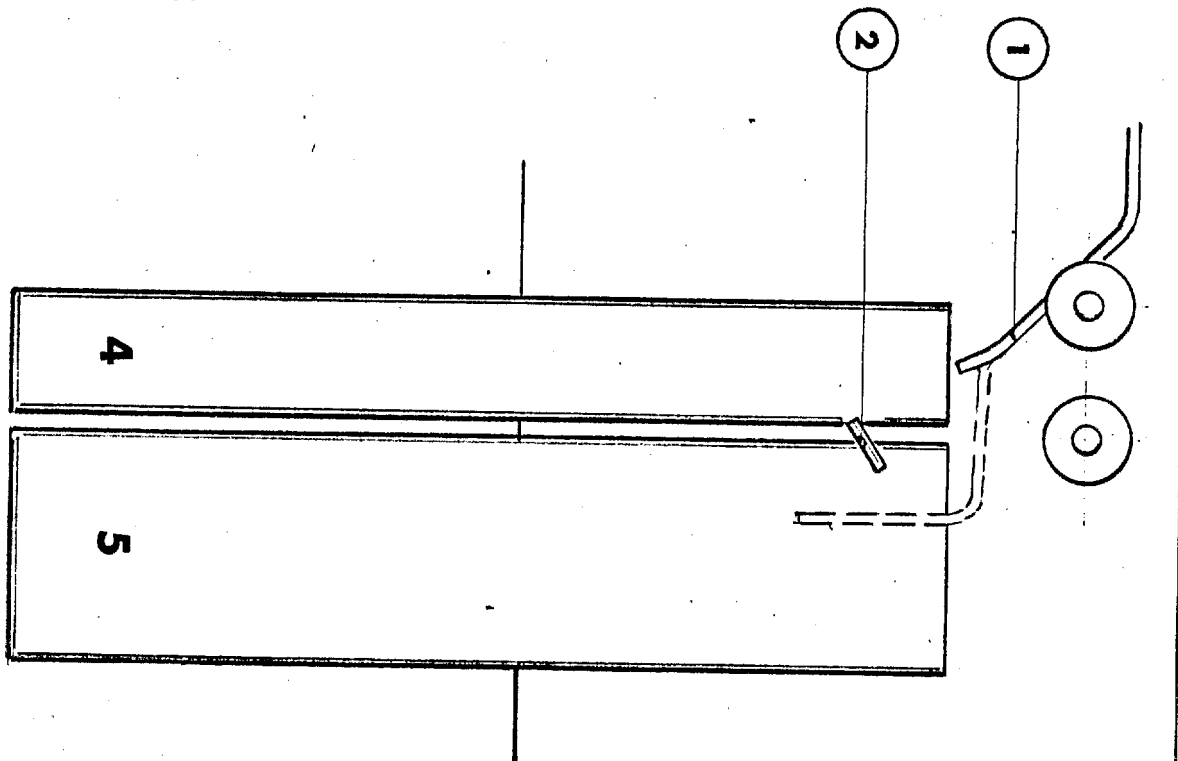

LEGEND

Sequence "B"

1. Number 4 replenishment line. Feeding photo flow solution into No. 5 tank
2. Rubber connection sleeve. Bypassing No. 4 tank
3. Replenishment adaptor for No. 5 tank
4. Wash water flow valve. To adjust wash water flow in No. 4 tank
5. Wash water feed line
6. Back view wash water flow valve
7. Wash water metering valve. To adjust wash water flow into No. 5 tank in proportion to photo flow replenishment rate
8. Wash water connection tube to No. 5 tank
9. Wash water connection tube to No. 4 tank

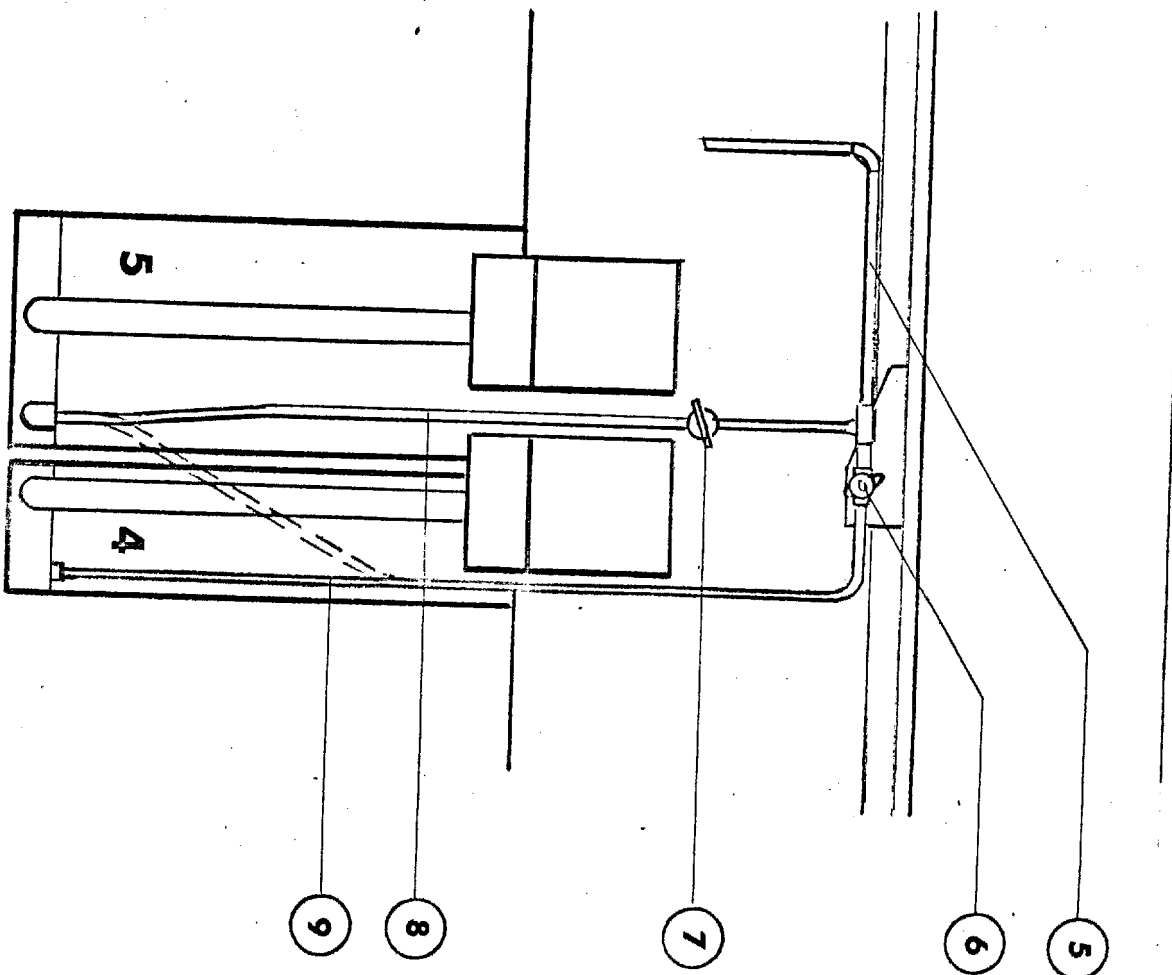
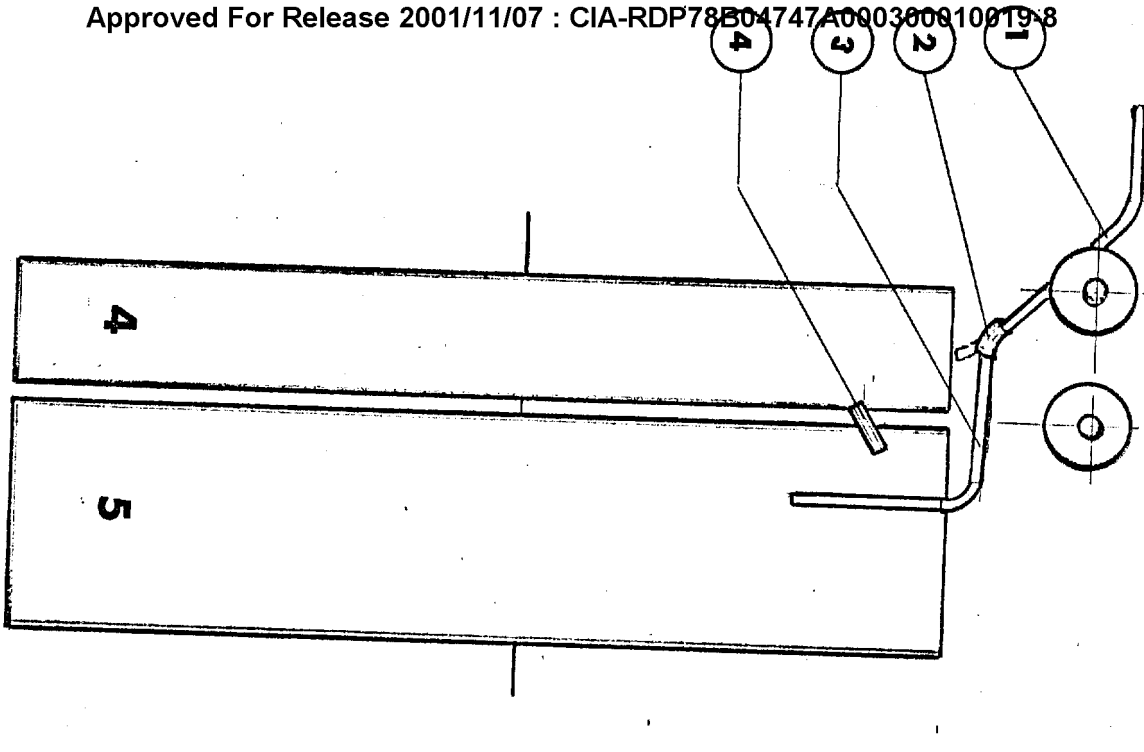

TANK 4&5 PLUMBING CONNECTIONS FOR PROCESS SEQUENCE 'B'

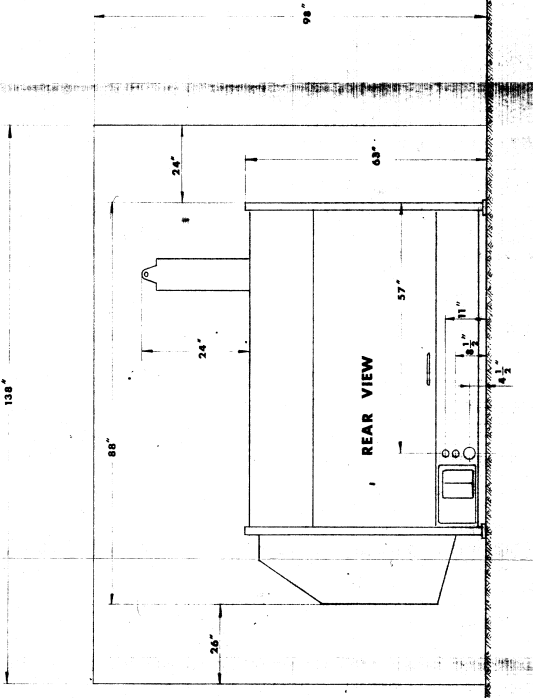
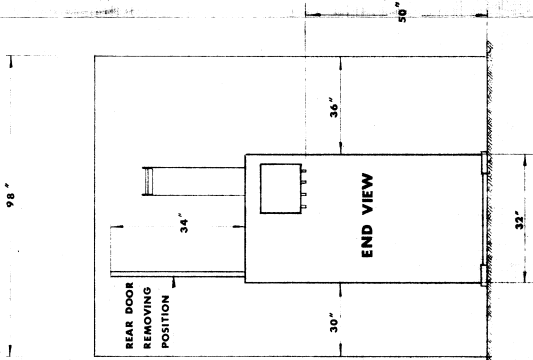
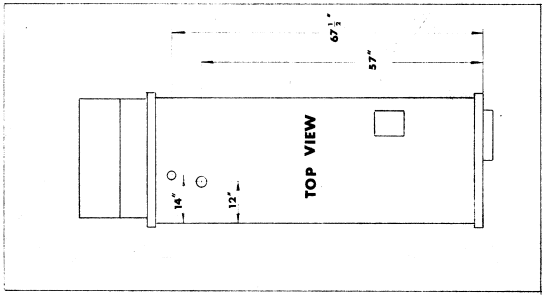

**PROCESSOR INSTALLATION - MINIMUM SPACE REQUIREMENT**

- NOTES**
1. TERMINAL BOARD NO.1 CONNECTION POINT.
  2. TERMINAL BOARD NO.2

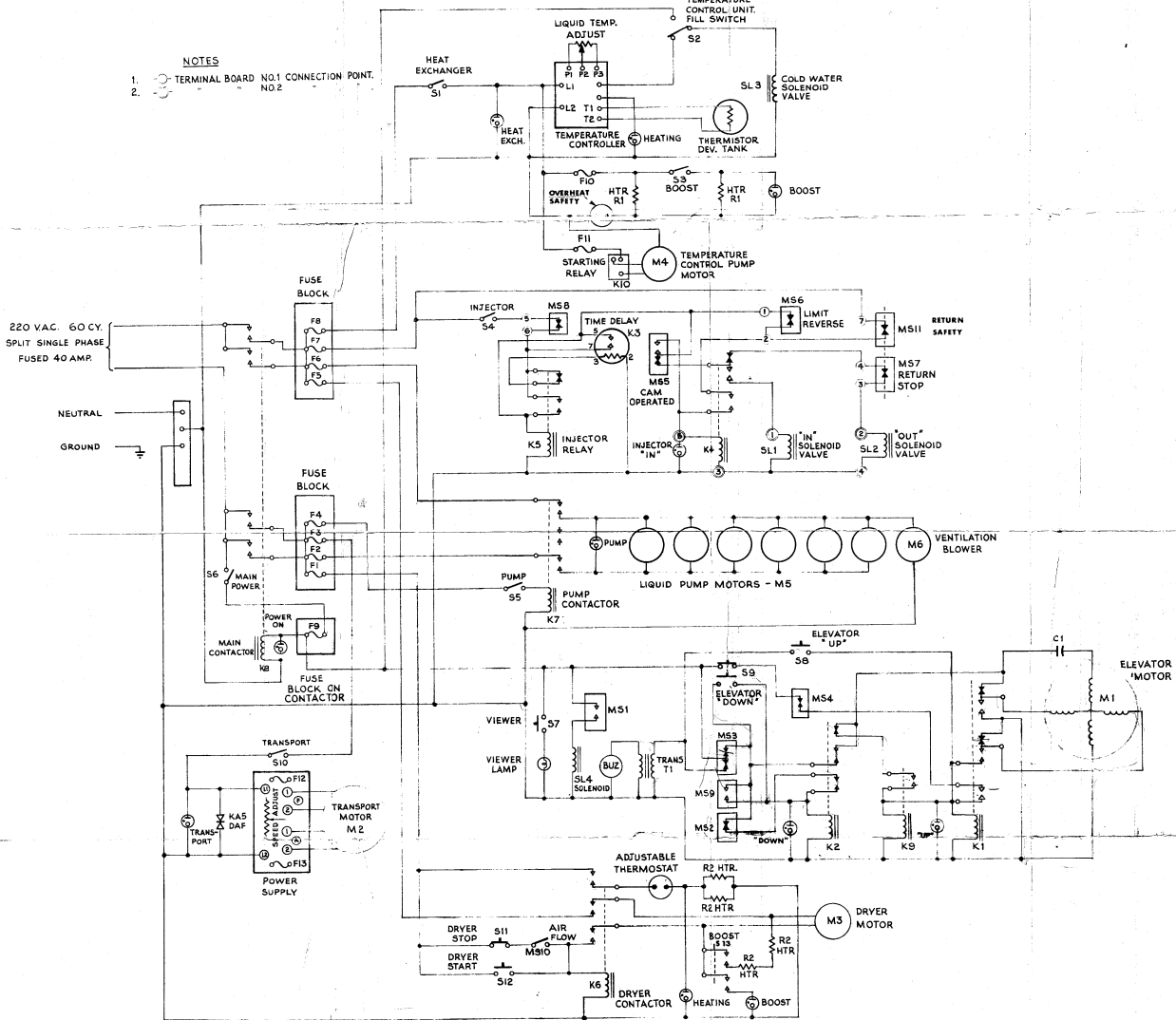

STATINTL