

# DATA WITHOUT WIRES

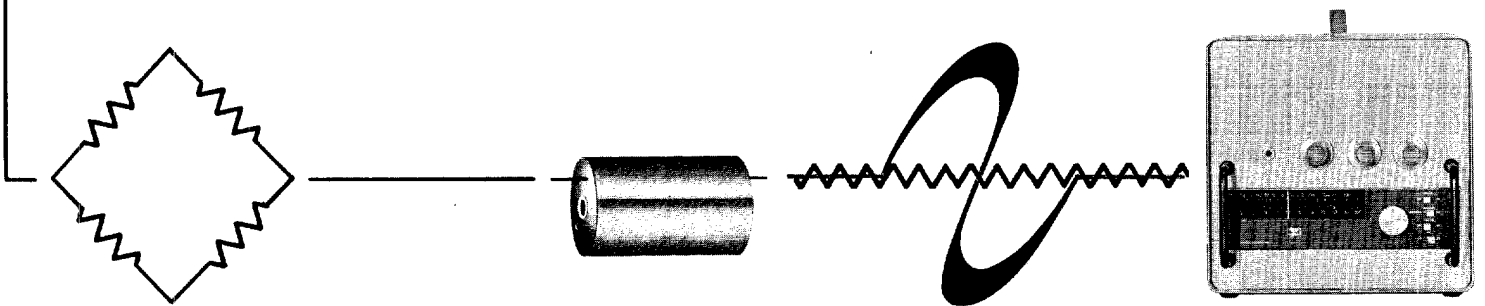

TELEMETRY FOR INDUSTRIAL TESTING, RESEARCH AND CONTROL

INDUSTRIAL ELECTRONETICS CORPORATION

PHONE: (305) 723-5382

POST OFFICE BOX 862

MELBOURNE, FLORIDA USA



Industrial Electronics Corporation takes pride in announcing ultra reliable, rugged, miniature and low cost measurement and telemetry systems now in production. These equipments designed and manufactured by engineers with over fifteen years of experience in Government Missile systems, are simplified, accurate and advanced versions of the military equipment but designed for industrial applications in measurement, control, and data analysis. Industrial operation and tests heretofore impossible or made with great difficulty and dubious accuracy, may now be made reliably and practically—results being presented in directly meaningful numbers and graphs.

Typical applications have been:

1. Internal strain measurements of rotating equipment, chains, vehicles, and projectiles—eliminating slip rings and wires.
2. Measurements of vibration, acceleration, strain, temperature, pressure, magnetic fields, electrical current and voltage, some to destructive proportions, may be made under difficult conditions such as at high electrical potentials, in fluids, steam, or high velocity gases.
3. Measurement under actual operating conditions of vehicles and machinery without restricting their movements or otherwise disturbing their normal functions.
4. Analysis of data to: determine resonant frequencies, make strain-weighted fatigue-life predictions, determine stress concentrations, locate operating hot spots, and determine power losses.
5. Control and feed-back links in automatic control systems for performing functions such as: laying of submarine cable, ice detection and melting, operation of protective circuit breakers, and over temperature control of electric motors.

Many models of measurement, control, telemetry, and analysis equipment are available from stock for immediate delivery. Custom modifications are supplied in 30 to 60 days and special purpose equipment is usually supplied within 90 days. Your inquiries are invited and special configurations of our telemetry products or simplified low cost instrumentation of almost any nature will be quoted upon request.

INDUSTRIAL ELECTRONETICS CORPORATION  
 Conrad H. Hoepfner  
 President

## WHAT IS TELEMETRY

Radio Telemetry provides a method for transmitting data by radio and presents a dc voltage output to a readout equipment or recorder. Radio telemetry may be most advantageously employed where wired connections are impossible, unsafe or technically undesirable.

I. E. C. Telemetry Systems are FM/FM. That is, both the bridge exciting carrier and radio carrier are frequency modulated. Frequency modulation provides better noise rejection and greater freedom from interference under adverse environments than amplitude modulation.

Radio Telemetry is a novel tool to industry for scientific measurements. Its range of application is limited only by the user's imagination. Some suggested application areas are:

Rotating Machinery — Slipringless Data Acquisition  
 Distant Logging Center Data Transmission  
 Patient Monitoring in Physiological Studies  
 Kiln Temperature Measurements

Transmission Lines  
 Troublesome Wire Links  
 Vehicular or Sled Tests  
 Railroad Equipment Studies  
 Hazardous Locations

Radio Telemetry has been developed by and primarily employed in government associated programs. Industrial applications have been retarded and restricted by technological inadequacies and financial considerations. I. E. C. aims to meet the requirements of industry—ACCURATE MEASUREMENT AT LOW COST.

A telemetry system consists of a completely transistorized transmitting station and a receiving station. Transmitters are potted in Epoxy Resin to provide rugged construction for environmental extremes. Standard systems utilize the 88 mc—108 mc band. However, special systems are available for operation in any band from 66 mc—110 mc.

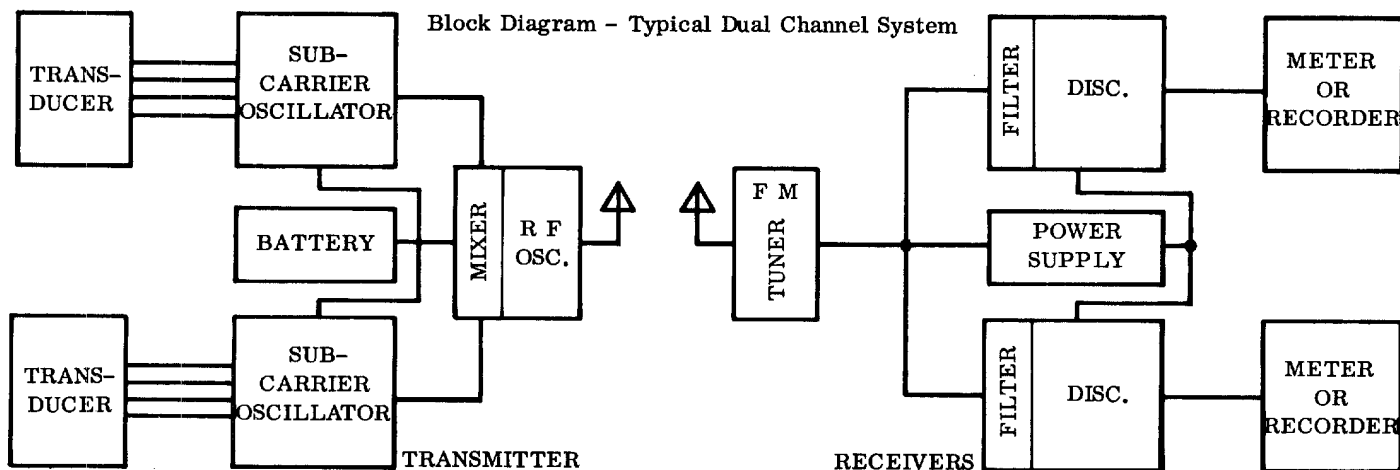

Subcarrier Oscillator provides the excitation voltage for the parameter detecting bridge. The output of the bridge modulates the frequency of the sub-carrier (FM).

RF Oscillator is the Radio Carrier. The frequency of the subcarrier oscillator modulates the frequency of the Radio Carrier (FM).

Battery provides all dc voltage requirements for the transmitting system including the transducer

FM Tuner tuned to RF oscillator frequency receives the transmitted signal.

Subcarrier Discriminator detects changes in the frequency of the subcarrier oscillator and converts such changes into dc voltage output equivalents. Thus, amplitude, frequency and waveform of the transduced signal is reproduced.

Power Supply furnishes all required power for the receiver

25X1A

Approved For Release 2001/09/03 : CIA-RDP76-00451R000200010010-4

Approved For Release 2001/09/03 : CIA-RDP76-00451R000200010010-4

TELEMETRY  
COMMUNICATIONS  
REMOTE CONTROL  
PROTOTYPE DEVELOPING  
DATA SYSTEMS  
CONSULTANT SERVICES

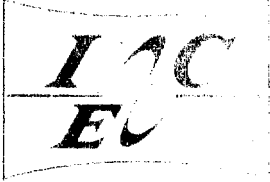

**INDUSTRIAL ELECTRONETICS CORPORATION**

PHONE: (305) 723-5382  
POST OFFICE BOX 862

ZIP CODE 32901  
MELBOURNE, FLORIDA

W A R N I N G

Units which are constructed using transistors, diodes, tunnel diodes, varicaps and other low voltage solid state devices should not be tested with instruments which apply test voltages such as direct reading ohmmeters, bridges, meggers, etc., or the units may be permanently damaged.

Signal generators with high AC output voltage and direct coupled connections should also not be used.

The discharge of static electricity by high voltage sparking from persons or moving objects such as belts, chains, etc., should not be allowed to contact solid state devices or permanent damage may result.

All encapsulated INDUSTRIAL ELECTRONICS CORPORATION units contain transistors or other parts which may be damaged by any of the above described applications of voltage.

## VOLTAGE CONTROLLED TRANSMITTER

General

The voltage controlled transmitter operates in the 88 to 108 mcs band. The unit has seven solder connecting pins to which all external connections must be firmly soldered. It may be exposed to temperatures from  $-40^{\circ}\text{C}$  to  $+125^{\circ}\text{C}$  during its normal operation; it may be immersed in common lubricating oils; and it may be subjected to shocks and continuous acceleration as great as 100 g without an external case. If greater shock or acceleration is desired, it should be contained in a firm steel case to support it on either of its flat sides during the high acceleration periods. Connections to the transmitter are made for input signals, batteries and antennas. Proper connections are clearly labeled on the accompanying drawing. There are two adjustments on the transmitter. The larger screw adjustment is for changing the radio frequency. The smaller adjustment is for zero offset provisions on the input voltage. In both cases as the screw is rotated clockwise the frequency of the carrier or the subcarrier respectively is increased. There are no limits which may damage either of these adjustments. The radio frequency slug travels completely through the transmitter and the offset adjustment is a 25-turn potentiometer which has a slipping clutch to prevent damage at each end.

Input Connections

Three signal input connections are provided. If the input impedance of the source is low, 10 ohms or less, it should be connected between ground pin #1 and input pin #2. If a high impedance source is to be used, pin #2 should be solder connected to ground pin #1 and the voltage applied from this junction to pin #3. Sources of intermediate impedance may be used either (a) between pins #1 and #2 or (b) between pin #3 and pin #2 by adding an appropriate shunt resistor in case (a) between pins #2 and #3 or in case (b) adding the proper series resistor between pins #1 and #2. Resistors should be chosen to bring the subcarrier to center frequency. Additional subcarrier frequency adjustments may be made by means of the 25-turn potentiometer. If a series resistance is used between the voltage source and pin #3 any magnitude of voltage may be measured. Furthermore, the zero offset adjustment range may be varied by connecting a resistor between pin #3 and pin #2 or pin #1 and pin #2.

Radio Frequency Considerations

The transmitter and its leads should be fixed securely to their mounting surfaces. Any motion between the transmitter and a closely spaced metal part will produce frequency modulation of the self-excited oscillator. This does not disturb the data until it becomes large enough to saturate the receiving discriminator. If motion between the transmitters, its leads and the mounting surface cannot be avoided then it is desirable to place insulating material between these parts and the mounting surface. Shielded leads to the input should be used whenever possible and the shield connected to ground pin #1. If it is not possible to use shielded leads, the radio frequency output may be coupled to the input circuit. If the intensity is great enough some of the radio voltage will be rectified and provide a zero offset to the subcarrier. In this case the offset adjustment should be changed after mounting of all the leads and antennas is complete. Usually no antenna is required on the transmitter if the receiving antenna can be placed in proximity to the transmitter. If greater range is desired short antennas (10" long) may be connected first to one pin, then the other, or both. A short bit of experimentation is usually required to provide a satisfactory transmitting antenna in cases where the transmitter is buried in metal engines, kilns, etc. Antennas longer than 10" may change the transmitter frequency excessively, particularly if they are mounted close to metal parts. Any length of wire may be used without damage to the transmitter but care should be taken to mount it properly for satisfactory operation at the desired frequency. In the event the transmitter is to be operated in oil or oil is allowed to splash on the transmitter, the radio frequency tuning hole should be filled at both ends to prevent the oil from alternately filling and draining from the hole, thereby changing the radio frequency.

Battery

The transmitter is designed to operate at a voltage of 9 volts. Proper operation may be obtained over the voltage range from 10 volts to 7.5 volts. An internal regulator stabilizes the voltage to the transmitter when the battery voltage varies. The regulator is an integral part of the temperature compensation system, consequently, the best stability with change in temperature is obtained when operated at 9 volts. For most stable operation as large a battery as the application permits should be used. Mercury cells and rechargeable nickel cadmium cells are recommended for their voltage stability.

Battery leads should be as short as possible. If long leads are used, shielded wire is recommended; the shield should be connected to the ground of the transmitter. Battery voltage should always be measured under load, preferably at the transmitter when the batteries are connected through the length of wire which will be used.

Batteries should have a current rating of at least 10 ma. Under-rated batteries or nearly discharged batteries may have a high internal impedance which will cause parasitic oscillations of the transmitter. If multiple cells are connected for a battery, all joints must be soldered. Pressure contacts will usually prove unsatisfactory.

The proper polarity should be observed in connecting the battery to the transmitter. If the battery is connected in reverse, excessive current will be drawn and internal overheating will soon damage the transmitter.

● INDICATES A P.W.

FOR INPUT  
REFER TO  
ATTACHED  
LITERATURE

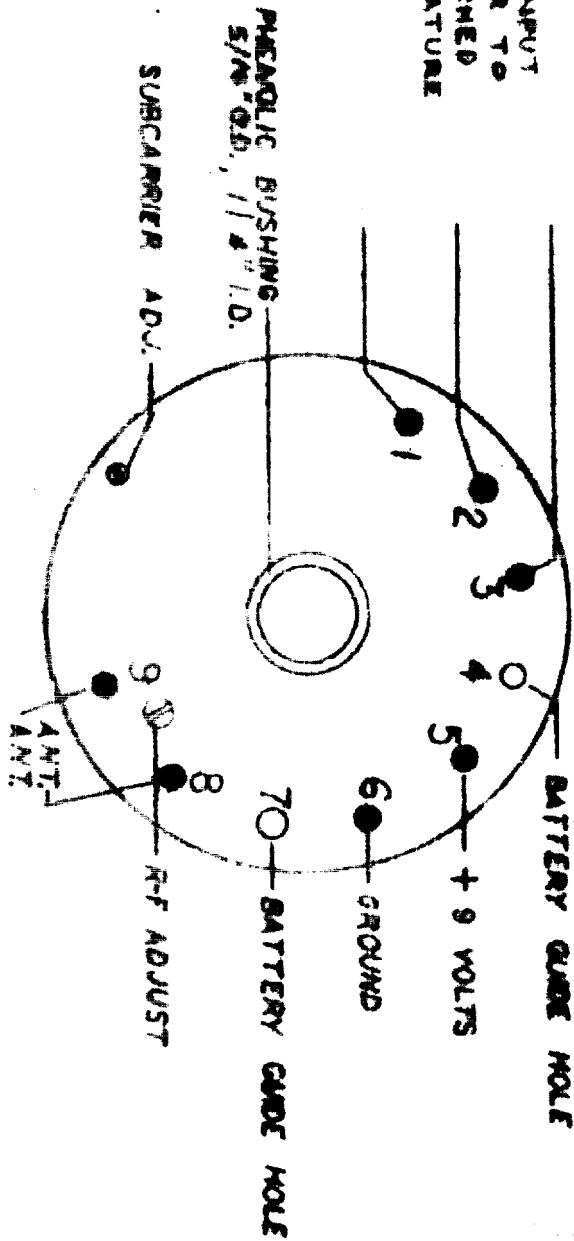

TRANSMITTER DIA. 1-3/8"  
PIN RADIUS 9/16"

INDUSTRIAL ELECTRONICS CORP.	
Maitland, Florida	
Part. No. 292R	Date 4/29/66
T-52 TRANSMITTER	
Dr. <i>Scott</i> <i>Kraft</i> Scale 2:1	
CR. <i>AKJ</i>	REV.
APP.	REV.

INDUSTRIAL ELECTRONETICS CORPORATION

P. O. Box 862, Melbourne, Florida

WARRANTY

The Industrial Electronetics Corporation warrants its products to be free from defects in materials and workmanship and to operate in accordance with published specifications upon shipment from its factory in Melbourne, Florida.

All telemetry and remote control transmitters and receivers are warranted for an additional period of 60 days following shipment from the factory. If, after our inspection of the equipments, defects in workmanship or materials are found, the units will be repaired at no charge to the customer.

It has been found impractical to repair epoxy encapsulated units. For these units a warranty is provided for six months following their shipment from our factory. If, the equipment is returned to our factory within a period of six months and our examination discloses no evidence of misuse, the equipment will be replaced with a similar equipment at a charge of one-half the list price, providing a purchase order for this replacement equipment is received within six months of the date of shipment of the first unit from our factory.

Exception to the above warranty is taken if failures occur in vacuum tubes, lamps, fuses, transistors, diodes, batteries and other components which by their nature have an unpredictable life span. If failure or malfunction is found to be caused by failure of one or more of the above listed components, the units will be repaired, if possible, and a nominal charge will be made for materials and labor; encapsulated units will be replaced at the standard price for these units.

Under no circumstances is the Industrial Electronetics Corporation liable for consequential damages.

Representatives of the Industrial Electronetics Corporation are not authorized to accept defective equipment under this warranty nor to change the conditions of the warranty. In the event a malfunction is determined, it is suggested that the malfunction be described in writing to the company. It is very often possible to diagnose the malfunction and suggest corrective measures by mail or telephone. If equipment is to be returned to the factory it should be shipped prepaid to the following address:

Industrial Electronetics Corporation  
P. O. Box 862  
Melbourne, Florida  
32902



READ - IMPORTANT

Approved For Release 2001/09/03 : CIA-RDP76-00451R000200010010-4

the transportation company in perfect condition. Do not accept any goods showing external evidence of damage unless agent of the carrier furnishes you with copy of Damage Report showing full description of breakage, or have the agent show damage notation on delivery receipt or freight bill. If you give a clear receipt for goods damaged or lost in transit, you do so at Your Own Risk.

CONCEALED DAMAGE. Should the damage not be discovered until after the goods are unpacked, notify the local agent of the delivering carrier immediately and request that an inspection be made and a report furnished to you showing full description of breakage, or have agent put a concealed damage notation on the freight bill.

Forward Damage Report or destination freight bill bearing damage notation immediately to us and retain the damaged equipment until disposition is furnished by the carrier or IEC.

Insp. by *77. E. W.*

Approved For Release 2001/09/03 : CIA-RDP76-00451R000200010010-4

IN CASE OF COMPLAINT, REGARDING DEFECTIVE WORKMANSHIP OR MATERIALS, TEAR OFF AND RETURN THIS TICKET TO:

Industrial Electronics Corp.  
P. O. Box 862, Melbourne, Fla., U.S.A.

USERS OF OUR EQUIPMENT

INDUSTRIAL ELECTRONETICS CORPORATION

PHONE: (305) 723-5382  
POST OFFICE BOX 862

ZIP CODE 32901  
MELBOURNE, FLORIDA

TELEMETRY  
COMMUNICATIONS  
REMOTE CONTROL  
PROTOTYPE DEVELOPING  
DATA SYSTEMS  
CONSULTANT SERVICES

Boston Edison Company Boston, Massachusetts	*Newport News Shipbuilding & Drydock Company Newport News, Virginia	*Saginaw Steering Gear Div., General Motors Corp. Saginaw, Michigan
American Telephone & Telegraph Company Murray Hill, N. J.	General Electric Co. Schenectady, New York	Food Machinery Corporation San Jose, California
Georgia-Alabama Electric Power Co., Birmingham, Ala.	*Forrestal Research Labs. Princeton, New Jersey	Cordis Corporation Miami, Florida
*Preformed Line Products Co. Cleveland, Ohio	Ferro Corporation Cleveland, Ohio	A. O. Smith Corporation Milwaukee, Wisconsin
*Allis Chalmers Co. Milwaukee, Wisconsin	*S. & C. Electric Company Chicago, Illinois	Joy Manufacturing Corp. New Philadelphia, Ohio
*Westinghouse Electric Co. East Pittsburgh, Pa.	*International Harvester Co. Melrose Park, Illinois	*The Garrett Corp. AI Research Division Phoenix, Arizona
Westinghouse Electric Co. Trafford, Pa.	*International Harvester Co. Chicago, Illinois	Detroit Edison Corp. Detroit, Michigan
*Westinghouse Electric Co. Lester, Pa.	N. Y. Central Railroad Cleveland, Ohio	Southern Electric Service Co. Birmingham, Alabama
U. S. Army Ft. Belvoir, Virginia	*Falk Corporation Milwaukee, Wisconsin	*Ebasco Services, Inc. New York, New York
*U. S. Army Ft. Eustis, Virginia	*Phoenix Rheinrohr Duisburg, W. Germany	*Kansas City Power & Light Clinton, Missouri
U. S. Air Force Patrick AFB, Florida	*Verein Deutscher Eisenhüttenleute Dusseldorf, W. Germany	Scripps Clinic & Research Foundation La Jolla, California
*U. S. Navy Cutler, Maine	University of Berlin Berlin, W. Germany	*Chain Belt Company Milwaukee, Wisconsin
*U. S. Navy Philadelphia, Pa.	Okura & Co., Inc. New York, New York	Mixing Equipment Company Rochester, New York
Assoc. of Amer. Railroads Chicago, Illinois	Furukawa Electric Ltd. Nikko Copper Works, Japan	*Dana Corporation Ft. Wayne, Indiana
*Brewer Engineering Lab. Marion, Massachusetts	General Motors Corp. Allison Division Indianapolis, Indiana	Cooper-Bessemer Corp. Mt. Vernon, Ohio
*Link Belt Company Indianapolis, Indiana	*General Motors Corp. Research Center Warren, Michigan	Arizona State University Tempe, Arizona
General Electric Co. Pittsfield, Mass.	*B. F. Goodrich Co. Troy, Ohio	U. S. Army Engineers Vicksburg, Mississippi
*General Electric Co. Erie, Pennsylvania	*Lycoming Div., Avco Corp. Stratford, Connecticut	Diamond Chain Co. Indianapolis, Indiana
General Electric Co. Cincinnati, Ohio	Aro, Incorporated Tullahoma, Tennessee	*Ford Motor Company Livonia, Michigan
General Electric Co. Louisville, Kentucky	Phelps Dodge Corp. Douglas, Arizona	Philadelphia Gear Co. Philadelphia, Pennsylvania
General Electric Co. Philadelphia, Pa.		Sun Ship Company Philadelphia, Pennsylvania

\*Indicates repeat orders

# TRANSMITTERS

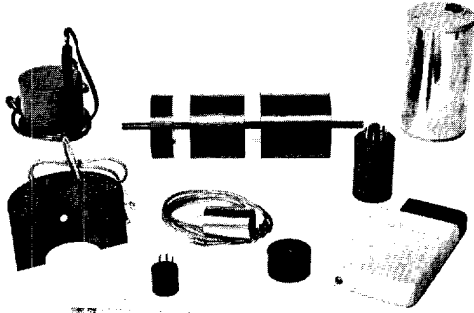

Various standard forms and sizes of telemetry transmitters and accessories are available. Our telemetry circuits may be cast in most any form required or may be cast in the test fixture itself. Write us of your requirements.

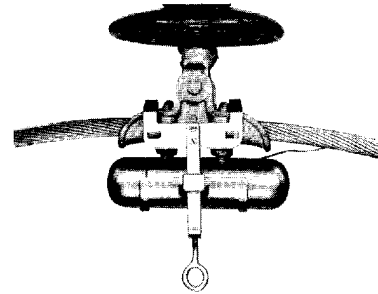

Transmitter in corona shield and weatherproof case for the measurement of vibratory strain and acceleration on high-voltage transmission lines to predict points of fatigue failure during high wind and icing conditions. Photo Courtesy of Preformed Line Products Co.

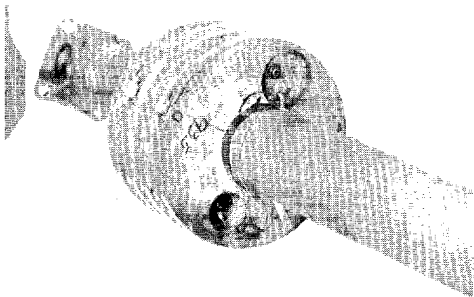

Drive Shaft 4 inches diameter. Instrumented for torque tests using T60 Transmitter.

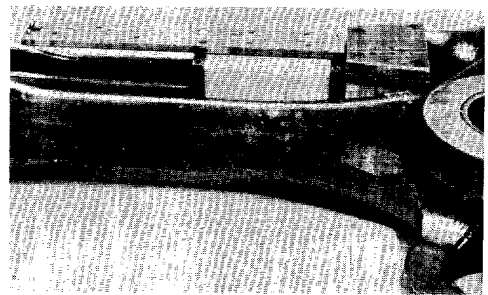

Subminiaturization of Transmitter permits mounting in confined areas with the transducer. Shown a Transmitter in the connecting rod of a diesel engine to measure temperature and strain during operation. Photo courtesy of General Electric Co.

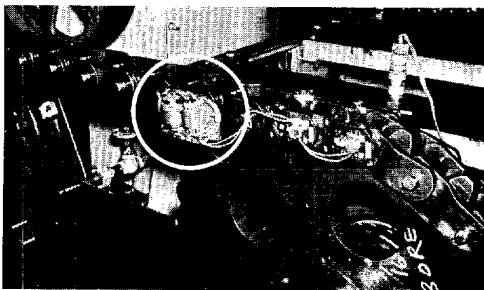

Application of subminiature T61 Transmitter for measurement of strain in links of a chain. Photo courtesy of Chain Belt Co.

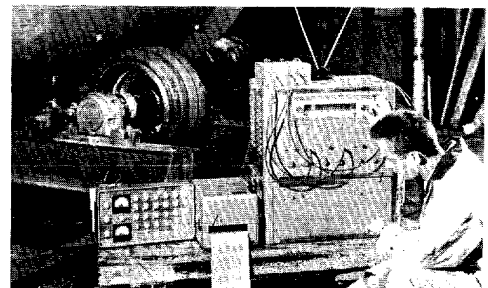

Measurement of strain in a Grinding Mill. Photo courtesy of Allis-Chalmers Manufacturing Co.

# RECEIVERS

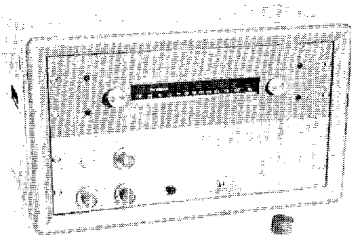

Model R61 Receiving Station with period controlled discriminator. Model R61PL has Phase - Lock Discriminator. Transmitter Model T66 in foreground.

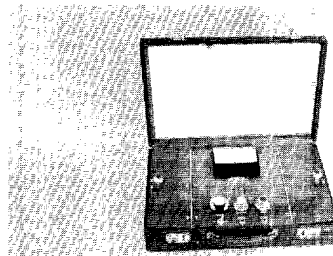

Model R69 Receiving Station. All solid state circuitry with self-contained rechargeable batteries, timed battery charger and output indicating meter.

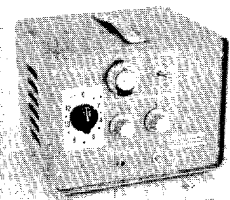

Model R70 Receiving Station. All solid state circuitry with self-contained rechargeable batteries and timed battery charger.

## OTHER PRODUCTS

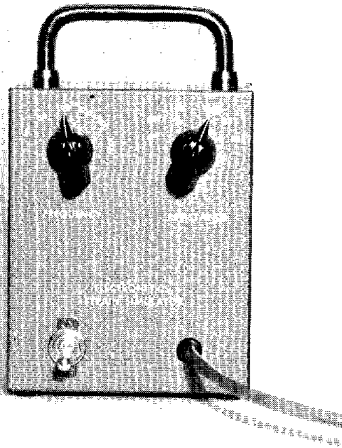

Model S-200 Strain Simulator Dynamic Calibrator is a resistance strain gage calibrator which permits step selection of resistance values in parallel with strain gage. Resistance is chopped in at frequencies from 10 cps to 3,000 cps. Five resistance steps are provided. Unit has self contained batteries.

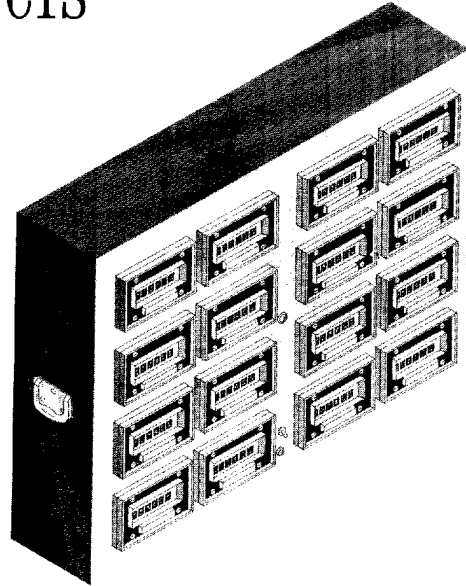

Model FA 62 Fatigue Analyzer. This instrument records the number of strain reversals through each of  $n$  preset levels or each of  $n+1$  adjacent levels or each of  $n+2$  adjacent levels, etc. Response is from 0 to 10 kc with input levels from 10 mv to 10v full scale.

## SERVICES (Design and Production)

Special Instruments or Systems. Remote Control Systems. Control and Shutdown. Proportional Control. Production.

Consultant Services in the fields of:  
Telemetry  
Data Acquisition and Processing  
Antennas  
RF Links and Systems  
Engineering Tests

## ORDERING INFORMATION

When requesting a quotation or placing an order please include the following:

1. Environmental conditions
2. Size or space limitations
3. Type of recorder to be used and input impedance
4. Transmission distance
5. Transducer employed and its resistance

Representatives are located throughout the United States and in many foreign countries. Your representative is:

TELEMETRY SYSTEMS

TELEMETRY  
COMMUNICATIONS  
REMOTE CONTROL  
PROTOTYPE DEVELOPING  
DATA SYSTEMS  
CONSULTANT SERVICES

INDUSTRIAL ELECTRONETICS CORPORATION

PHONE: (305) 723-5382  
POST OFFICE BOX 862

ZIP CODE 32901  
MELBOURNE, FLORIDA

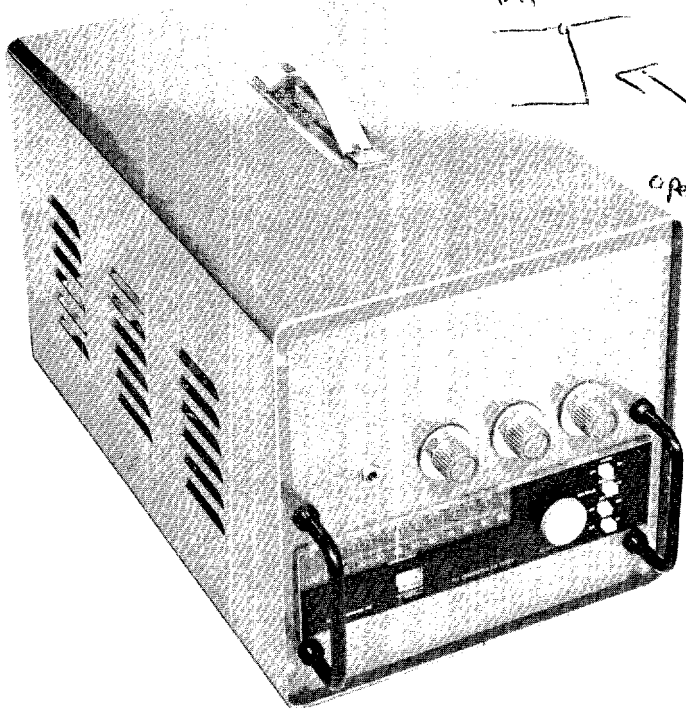
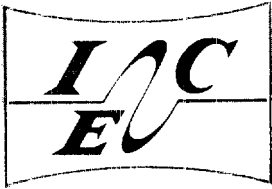

RECEIVING STATION  
Model R62 FM Receiving Station available in 1 to 3 Channels. Completely transistorized. Operates from AC or DC sources.

TRANSMITTERS:

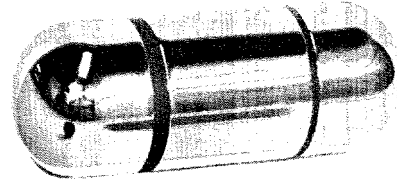

PORTEL 1 TO 3 CHANNEL TRANSMITTER WITH SUBCARRIER OSCILLATORS AND BATTERY IN CORONA-PROOF CASE FOR MEASUREMENTS IN HIGH VOLTAGE ELECTRICAL FIELDS.  
*10" Antenna*



MINIATURE SINGLE CHANNEL TRANSMITTER WITH SUBCARRIER OSCILLATOR 1 3/8" D x 3/4" L.



MINIATURE SINGLE CHANNEL TRANSMITTER WITH SUBCARRIER OSCILLATOR 1" D x 1 1/2" L.



STRAIN-TEL SINGLE CHANNEL FM TRANSMITTER MODULATED DIRECTLY BY OUTPUT OF A STRAIN GAGE.



ROTEL 2 CHANNEL TRANSMITTER FOR CLAMPING ON SHAFTS ELIMINATING SLIPRINGS.

OBTAIN ACCURATE

DATA WITHOUT WIRES

Whatever your data acquisition or process monitoring problem, we solicit the opportunity of offering an economical, accurate solution with FM/FM Industrial Telemetry.

Measure or monitor most any parameter with "Wire-Less" instrumentation, in the laboratory or under actual field operating conditions.

PROVEN APPLICATIONS:

Control and feedback links. Fatigue life predictions; temperature monitoring and control; data from operating machinery under field operating conditions; remote indications; measurements in high voltage fields; transmission of data from pistons and connecting rods of operating engines.

TEMPERATURE  
ACCELERATION  
VOLTAGE  
TORQUE

PRESSURE  
LOAD  
CURRENT  
STRAIN

POSITION

Telemetry Systems

I. TRANSMITTERS

Strain:

- Model T60-( ) (Dash number represents number of channels) 2-1/2" D. FM/FM transmitter provides excitation for a 4 arm strain gage bridge for 1, 2, or 3 channels. Three inch chrome plated steel case for corona prevention optional, order Model TC60-( ).
- Model T61 1" D. x 1-1/2" L. single channel FM/FM, bridge controlled.
- Model T62 1-3/8" D. x 3/4" L. single channel FM/FM, bridge controlled.
- Model T63 3/4" D. x 1/2" L. directly modulated by output of a single strain gage; gage excitation 1.5 V battery @ 3 Ma.
- Model T65-( ) A rotating torus to eliminate slip rings on rotating shafts. Bridge controlled; I.D. 1/2" to 2"; O.D. 3-9/16"; 1 or 2 channels available.
- Model T66 High temperature operation from -40°C to +100°C; bridge controlled 1-3/8" D. x 1-1/2" L.

Temperature:

- Model T40 1-3/8" D. x 3/4" L. FM/FM, thermocouple controlled with cold junction compensation, operating temperature -40°C to +125°C.
- Model T41 1" D. x 1-1/2" L. FM/FM, otherwise same as Model T40.
- Model T42 1-3/8" D. x 3/4" L. FM/FM, resistance gage controlled, operating temperature -40°C to +125°C.
- Model T43 1" D. x 1-1/2" L., otherwise same as Model T42.
- Model T60-( ) Same as Model T60 above except with thermistor probe across one arm of self contained resistance bridge. Operating temperature -40°C to +50°C.

Acceleration:

- Models T60 through T66 above for strain gage bridge accelerometers.
- Model T54 1-3/8" D. x 1-1/2" L. for piezo-electric accelerometers.

Voltage & Current:

- #1650 Model T50 0 to 100 Mv or 0 to 10 V range, 1-3/8" D. x 3/4" L., operating temperature -40°C to +125°C.
- Model T51 1" D. x 1-1/2" L., otherwise same as Model T50.
- #750 Model T52 0 to 25 Mv range, 1-3/8" D. x 3/4" L., operating temperature -40°C to +125°C.
- Model T53 1" D. x 1-1/2" L., otherwise same as Model T52.
- Model T54 High impedance (greater than 100 megohms) input 0 to 50 Mv, 1-3/8" D. x 3/4" L.
- Model T55 1" D. x 1-1/2" L., otherwise same as Model T54.

Pressure, torque, flow, position, velocity, power, biological phenomena, weather data, etc. may be telemetered by appropriate choice of transducers and telemeters listed above.

II. RECEIVING STATIONS to operate with all Electronics transmitters

- #1200 Model R61PL-( ) Phase-locked loop discriminator, standard frequencies are 1600, 4000 and 10,000 cps; includes vacuum tube receiver.
  - Model R61-( ) Transistorized discriminator and vacuum tube receiver, standard frequencies are 1600, 4000 and 10,000 cps.
  - Model R62-( ) Completely transistorized receiving station to operate from either 110V a-c or batteries (customer option).
  - Model R63 Single channel battery operated "briefcase" receiving station.
- FM/FM radio frequencies available: 88 to 108 Mcs, (or 75 to 85 Mcs, or 68 to 75 Mcs.)

#1150 R64A Transistorized, portable, lite weight

Special order for overseas.

"THE RADIATING STRAIN GAGE"

Model T63

INDUSTRIAL ELECTRONETICS CORPORATION

PHONE: (305) 723-5382  
POST OFFICE BOX 862

ZIP CODE 32901  
MELBOURNE, FLORIDA

TELEMETRY  
COMMUNICATIONS  
REMOTE CONTROL  
PROTOTYPE DEVELOPING  
DATA SYSTEMS  
CONSULTANT SERVICES

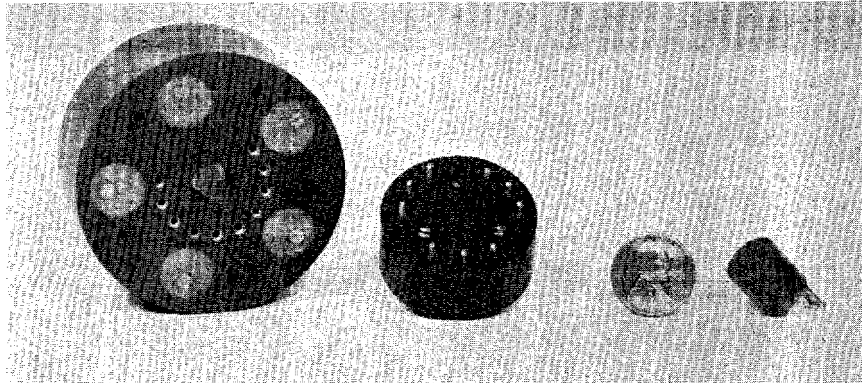

Compare the size of the five, three and single channel STRAINTEL

The simplest, least expensive, and most versatile of telemetry systems -- a revolutionary development in miniature oscillators. The voltage output from a single active strain gage, battery excited, results in a modulated RF signal which is received by an FM receiver. The five channel unit pictured above is complete with rechargeable batteries.

A single 1.5 volt cell connected in series with a 60 ohm strain gage (gage factor 2) and a 390 ohm resistor produces a voltage variation of 0.2 mv from 500 millionths of an inch per inch strain which typically results in a 0.8 volt output of the IEC receiving station.

**Advantages:** There is no need for bridge balancing or capacitance balancing. Transmitter power consumption is extremely small with only 2.5 ma of current required from a 1.5 volt battery or from our new 0.3 V battery. Standard arrangement provides from 10 to 20,000 cps frequency response. The physical size of the unit and versatility of form factor permits measurements requiring RF transmitted data heretofore impossible.

**Environment:** The temperature operating range is -40°C to 125°C. The unit is completely encapsulated in an impervious epoxy resin rendering the components positive protection from: stress, moisture, dust, thermal and mechanical shock, and tampering. It is currently in use in rotating equipment at speeds of 100,000 r.p.m.

SYSTEM SPECIFICATIONS  
USING IEC RECEIVING STATIONS

Standard Radio Frequency Band:	88-108 mc (tunable)	Operating Temperature Range:	-40°C to +125°C
Optional Radio Frequency Bands:	75-85 mc and 68-75 mc	Power:	2.5 ma @ 0.3 V
System Voltage Gain Factor:	4000 nominal	Controls:	RF frequency adjustment
Noise Level:	10 micro-volts approx.	Size:	
Minimum Strain:	40 micro-in/in	1 Channel (without battery):	3/4 inch dia. x 3/4 inch length or 3/8 inch dia. x 1-1/2 inches length
Frequency Response:	10-20,000 cps	3 Channels (without battery):	1-3/8 inches dia. x 3/4 inch length
Gage Voltage Variation:	0.2 mv for 500 micro-in/in		
Linearity Over-all:	+5% from best straight line to 3500 micro-in/in		

Other multi-channel configurations of the STRAINTEL are available to special order. The five channel unit complete with rechargeable battery is only 1-3/8" long by 2-1/2" in diameter.

## APPLICATIONS

### Stress Analysis

The STRAINTEL transmitter was created primarily as a design tool to render dynamic measurement of loaded structural members. As such it is invaluable for final determinations of imposed loads, adequacy of designs, and analysis of situations to be engineered.

### Alarm Trigger

The transmitter is useful in operating alarms at points distant from the monitor which are not easily linked by wire. In this type of application, any number of transmitters properly tuned can be serviced at one point by a single receiving station. A strain gage need not necessarily be a part of this system as any device impressing the required voltage at the transmitter will create the necessary alarm at the receiver. This alarm may be acted upon automatically by installation of the desired auxiliary equipment. Installation of the proper transducers will permit the surveillance of pressure, heat, temperature, mechanical movement, stress, strain, load, weight, acceleration, light, etc. In certain applications, thermocouples produce sufficient electrical energy to operate the unit WITHOUT THE NEED OF BATTERIES!

## RECEIVING STATIONS

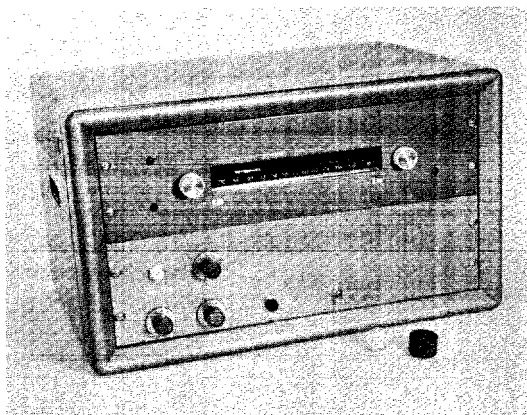

Model R61 PL Receiving Station Shown Above  
Top Panel: STRAINTEL Receiver Model R-65  
Bottom Panel: Discriminator Model 61-D  
Bottom Right Of Picture: STRAINTEL Transmitter Model T-63

Since the STRAINTEL does not include a subcarrier oscillator, the receiving station need not incorporate a discriminator. Considerable savings result on system cost. The receiving stations utilize standard tuners modified to improve sensitivity and linearity and, to reduce noise. They are mounted in standard IEC cabinets. As a result, a customer can procure a STRAINTEL low cost system with the advantages of telemetry, and at a future date, incorporate a discriminator for reception of data from transmitters utilizing a subcarrier oscillator.

### OTHER SYSTEMS IMMEDIATELY AVAILABLE

- R65 110 volt ac operated receiving station; panel mounted-vacuum tube circuitry.
- R66 Completely transistorized with optional 110 volt ac or battery power pack.
- R67 Completely transistorized with optional 110 volt ac or battery power pack.

FOR FURTHER INFORMATION WRITE OR CALL OUR REPRESENTATIVE  
NEAREST YOU



**Next 2 Page(s) In Document Exempt**

# DATA WITHOUT WIRES

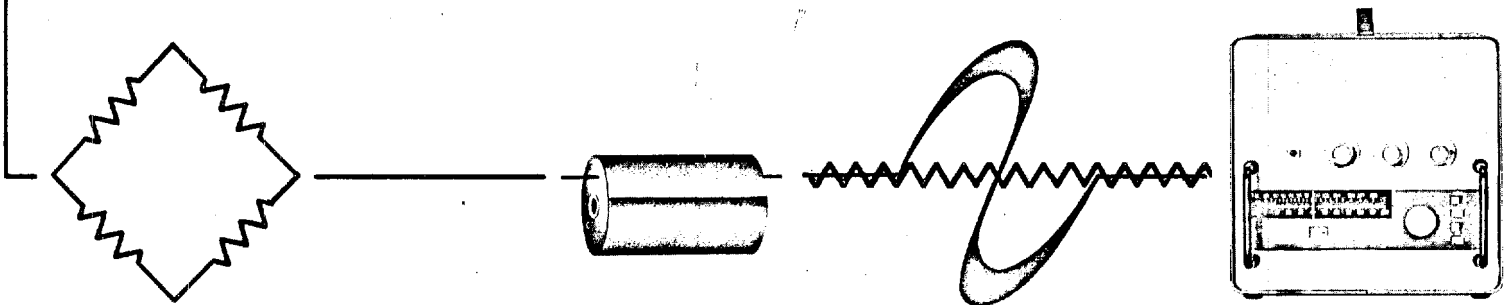

TELEMETRY FOR INDUSTRIAL TESTING, RESEARCH AND CONTROL

INDUSTRIAL ELECTRONETICS CORPORATION

PHONE (305) 733-5382  
Approved For Release 2001/09/03 : CIA-RDP76-00451R000200010010-4  
POST OFFICE BOX 899  
MELBOURNE, FLORIDA USA



Industrial Electronics Corporation has developed the most measurement and telemetry systems now in production. These equipments designed and manufactured by engineers with over fifteen years of experience in Government Missile systems, are simplified, accurate and advanced versions of the military equipment but designed for industrial applications in measurement, control, and data analysis. Industrial operation and tests heretofore impossible or made with great difficulty and dubious accuracy, may now be made reliably and practically—results being presented in directly meaningful numbers and graphs.

Typical applications have been:

1. Internal strain measurements of rotating equipment, chains, vehicles, and projectiles—eliminating slip rings and wires.
2. Measurements of vibration, acceleration, strain, temperature, pressure, magnetic fields, electrical current and voltage, some to destructive proportions, may be made under difficult conditions such as at high electrical potentials, in fluids, steam, or high velocity gases.
3. Measurement under actual operating conditions of vehicles and machinery without restricting their movements or otherwise disturbing their normal functions.
4. Analysis of data to: determine resonant frequencies, make strain-weighted fatigue-life predictions, determine stress concentrations, locate operating hot spots, and determine power losses.
5. Control and feed-back links in automatic control systems for performing functions such as: laying of submarine cable, ice detection and melting, operation of protective circuit breakers, and over temperature control of electric motors.

Many models of measurement, control, telemetry, and analysis equipment are available from stock for immediate delivery. Custom modifications are supplied in 30 to 60 days and special purpose equipment is usually supplied within 90 days. Your inquiries are invited and special configurations of our telemetry products or simplified low cost instrumentation of almost any nature will be quoted upon request.

**INDUSTRIAL ELECTRONETICS CORPORATION**  
Conrad H. Hoepfner  
President

## WHAT IS TELEMETRY

Radio Telemetry provides a method for transmitting data by radio and presents a dc voltage output to a readout equipment or recorder. Radio telemetry may be most advantageously employed where wired connections are impossible, unsafe or technically undesirable.

I. E. C. Telemetry Systems are FM/FM. That is, both the bridge exciting carrier and radio carrier are frequency modulated. Frequency modulation provides better noise rejection and greater freedom from interference under adverse environments than amplitude modulation.

Radio Telemetry is a novel tool to industry for scientific measurements. Its range of application is limited only by the user's imagination. Some suggested application areas are:

- Rotating Machinery — Slipringless Data Acquisition
- Distant Logging Center Data Transmission
- Patient Monitoring in Physiological Studies
- Kiln Temperature Measurements

- Transmission Lines
- Troublesome Wire Links
- Vehicular or Sled Tests
- Railroad Equipment Studies
- Hazardous Locations

Radio Telemetry has been developed by and primarily employed in government associated programs. Industrial applications have been retarded and restricted by technological inadequacies and financial considerations. I. E. C. aims to meet the requirements of industry—ACCURATE MEASUREMENT AT LOW COST.

A telemetry system consists of a completely transistorized transmitting station and a receiving station. Transmitters are potted in Epoxy Resin to provide rugged construction for environmental extremes. Standard systems utilize the 88 mc—108 mc band. However, special systems are available for operation in any band from 66 mc—110 mc.

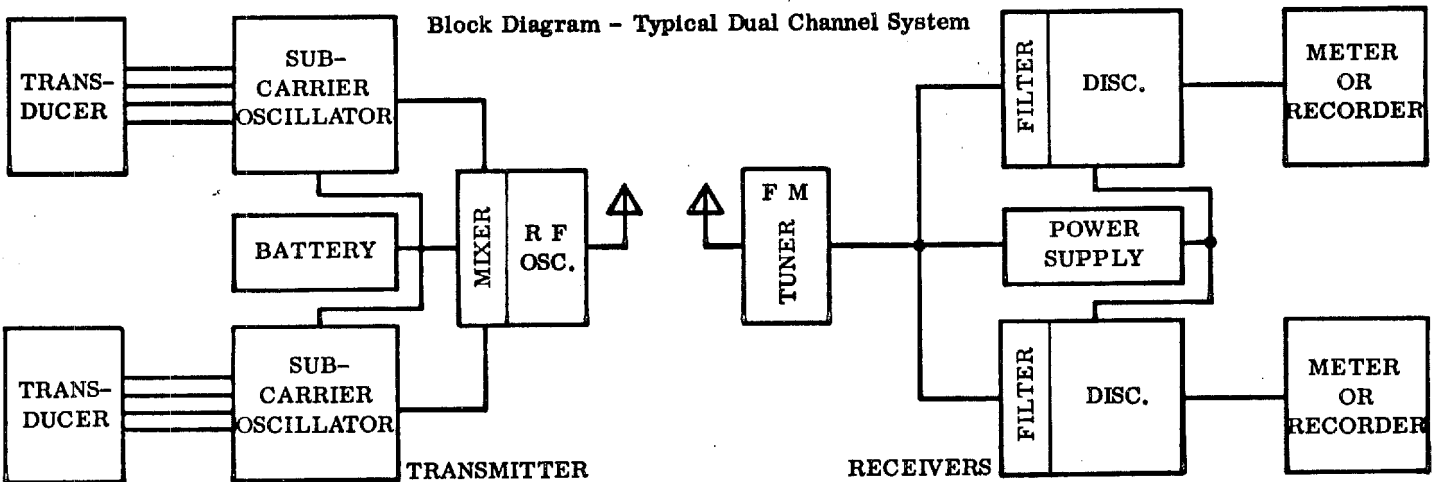

Subcarrier Oscillator provides the excitation voltage for the parameter detecting bridge. The output of the bridge modulates the frequency of the sub-carrier (FM).

RF Oscillator is the Radio Carrier. The frequency of the subcarrier oscillator modulates the frequency of the Radio Carrier (FM).

Battery provides all dc voltage requirements for the transmitting system including the transducer.

FM Tuner tuned to RF oscillator frequency receives the transmitted signal.

Subcarrier Discriminator detects changes in the frequency of the subcarrier oscillator and converts such changes into dc voltage output equivalents. Thus, amplitude, frequency and waveform of the transduced signal is reproduced.

Power Supply furnishes all required power for the receiver.

25X1A

Approved For Release 2001/09/03 : CIA-RDP76-00451R000200010010-4

Approved For Release 2001/09/03 : CIA-RDP76-00451R000200010010-4



## VOLTAGE CONTROLLED TRANSMITTER

General

The voltage controlled transmitter operates in the 88 to 108 mcs band. The unit has seven solder connecting pins to which all external connections must be firmly soldered. It may be exposed to temperatures from  $-40^{\circ}\text{C}$  to  $+125^{\circ}\text{C}$  during its normal operation; it may be immersed in common lubricating oils; and it may be subjected to shocks and continuous acceleration as great as 100 g without an external case. If greater shock or acceleration is desired, it should be contained in a firm steel case to support it on either of its flat sides during the high acceleration periods. Connections to the transmitter are made for input signals, batteries and antennas. Proper connections are clearly labeled on the accompanying drawing. There are two adjustments on the transmitter. The larger screw adjustment is for changing the radio frequency. The smaller adjustment is for zero offset provisions on the input voltage. In both cases as the screw is rotated clockwise the frequency of the carrier or the subcarrier respectively is increased. There are no limits which may damage either of these adjustments. The radio frequency slug travels completely through the transmitter and the offset adjustment is a 25-turn potentiometer which has a slipping clutch to prevent damage at each end.

Input Connections

Three signal input connections are provided. If the input impedance of the source is low, 10 ohms or less, it should be connected between ground pin #1 and input pin #2. If a high impedance source is to be used, pin #2 should be solder connected to ground pin #1 and the voltage applied from this junction to pin #3. Sources of intermediate impedance may be used either (a) between pins #1 and #2 or (b) between pin #3 and pin #2 by adding an appropriate shunt resistor in case (a) between pins #2 and #3 or in case (b) adding the proper series resistor between pins #1 and #2. Resistors should be chosen to bring the subcarrier to center frequency. Additional subcarrier frequency adjustments may be made by means of the 25-turn potentiometer. If a series resistance is used between the voltage source and pin #3 any magnitude of voltage may be measured. Furthermore, the zero offset adjustment range may be varied by connecting a resistor between pin #3 and pin #2 or pin #1 and pin #2.

Radio Frequency Considerations

The transmitter and its leads should be fixed securely to their mounting surfaces. Any motion between the transmitter and a closely spaced metal part will produce frequency modulation of the self-excited oscillator. This does not disturb the data until it becomes large enough to saturate the receiving discriminator. If motion between the transmitters, its leads and the mounting surface cannot be avoided then it is desirable to place insulating material between these parts and the mounting surface. Shielded leads to the input should be used whenever possible and the shield connected to ground pin #1. If it is not possible to use shielded leads, the radio frequency output may be coupled to the input circuit. If the intensity is great enough some of the radio voltage will be rectified and provide a zero offset to the subcarrier. In this case the offset adjustment should be changed after mounting of all the leads and antennas is complete. Usually no antenna is required on the transmitter if the receiving antenna can be placed in proximity to the transmitter. If greater range is desired short antennas (10" long) may be connected first to one pin, then the other, or both. A short bit of experimentation is usually required to provide a satisfactory transmitting antenna in cases where the transmitter is buried in metal engines, kilns, etc. Antennas longer than 10" may change the transmitter frequency excessively, particularly if they are mounted close to metal parts. Any length of wire may be used without damage to the transmitter but care should be taken to mount it properly for satisfactory operation at the desired frequency. In the event the transmitter is to be operated in oil or oil is allowed to splash on the transmitter, the radio frequency tuning hole should be filled at both ends to prevent the oil from alternately filling and draining from the hole, thereby changing the radio frequency.

Battery

The transmitter is designed to operate at a voltage of 9 volts. Proper operation may be obtained over the voltage range from 10 volts to 7.5 volts. An internal regulator stabilizes the voltage to the transmitter when the battery voltage varies. The regulator is an integral part of the temperature compensation system, consequently, the best stability with change in temperature is obtained when operated at 9 volts. For most stable operation as large a battery as the application permits should be used. Mercury cells and rechargeable nickel cadmium cells are recommended for their voltage stability.

Battery leads should be as short as possible. If long leads are used, shielded wire is recommended; the shield should be connected to the ground of the transmitter. Battery voltage should always be measured under load, preferably at the transmitter when the batteries are connected through the length of wire which will be used.

Batteries should have a current rating of at least 10 ma. Under-rated batteries or nearly discharged batteries may have a high internal impedance which will cause parasitic oscillations of the transmitter. If multiple cells are connected for a battery, all joints must be soldered. Pressure contacts will usually prove unsatisfactory.

The proper polarity should be observed in connecting the battery to the transmitter. If the battery is connected in reverse, excessive current will be drawn and internal overheating will soon damage the transmitter.

● INDICATES A PIN

FOR INPUT  
REFER TO  
ATTACHED  
LITERATURE

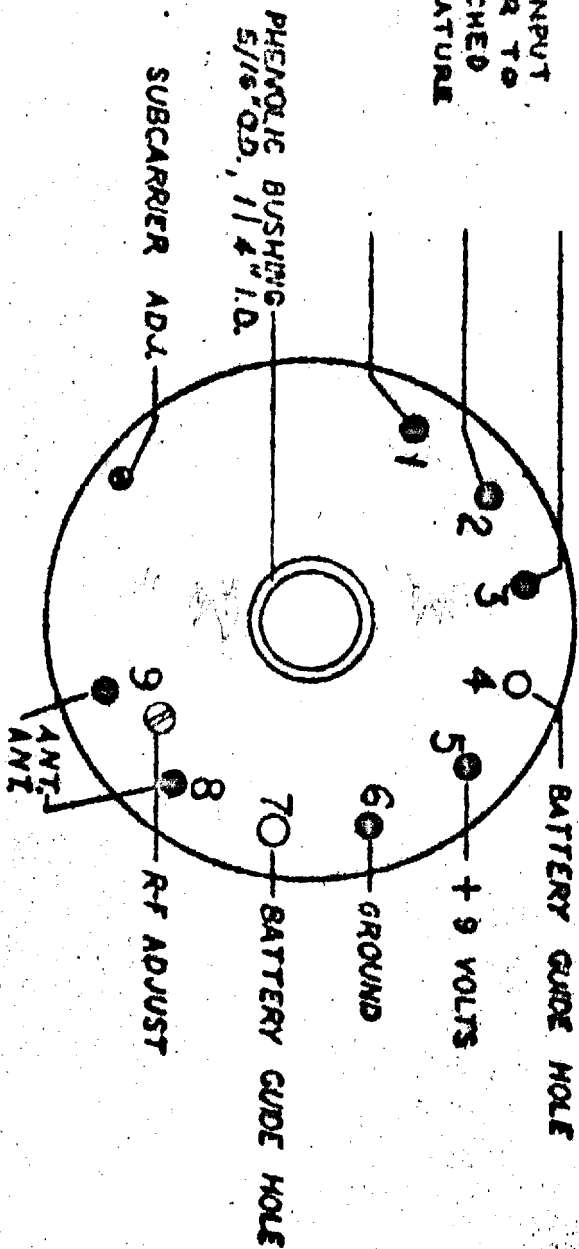

TRANSMITTER DIA. 1-3/8"  
PIN RADIUS 9/16"

INDUSTRIAL ELECTRONICS CORP.	
Melbourne, Florida	
Dwg. No. 292D	Date 7/20/66
<b>T-52 TRANSMITTER</b>	
Dr. Squig Kieckhefer	Scale 2:1
Cr. KLD	Pat.
App.	Rev.



**INDUSTRIAL ELECTRONETICS CORPORATION**

**P. O. Box 862, Melbourne, Florida**

**WARRANTY**

The Industrial Electronetics Corporation warrants its products to be free from defects in materials and workmanship and to operate in accordance with published specifications upon shipment from its factory in Melbourne, Florida.

All telemetry and remote control transmitters and receivers are warranted for an additional period of 60 days following shipment from the factory. If, after our inspection of the equipments, defects in workmanship or materials are found, the units will be repaired at no charge to the customer.

It has been found impractical to repair epoxy encapsulated units. For these units a warranty is provided for six months following their shipment from our factory. If, the equipment is returned to our factory within a period of six months and our examination discloses no evidence of misuse, the equipment will be replaced with a similar equipment at a charge of one-half the list price, providing a purchase order for this replacement equipment is received within six months of the date of shipment of the first unit from our factory.

Exception to the above warranty is taken if failures occur in vacuum tubes, lamps, fuses, transistors, diodes, batteries and other components which by their nature have an unpredictable life span. If failure or malfunction is found to be caused by failure of one or more of the above listed components, the units will be repaired, if possible, and a nominal charge will be made for materials and labor; encapsulated units will be replaced at the standard price for these units.

Under no circumstances is the Industrial Electronetics Corporation liable for consequential damages.

Representatives of the Industrial Electronetics Corporation are not authorized to accept defective equipment under this warranty nor to change the conditions of the warranty. In the event a malfunction is determined, it is suggested that the malfunction be described in writing to the company. It is very often possible to diagnose the malfunction and suggest corrective measures by mail or telephone. If equipment is to be returned to the factory it should be shipped prepaid to the following address:

**Industrial Electronetics Corporation  
P. O. Box 862  
Melbourne, Florida  
32902**

## USERS OF OUR EQUIPMENT

## INDUSTRIAL ELECTRONETICS CORPORATION

PHONE: (305) 723-5382  
POST OFFICE BOX 862

ZIP CODE 32901  
MELBOURNE, FLORIDA

TELEMETRY  
COMMUNICATIONS  
REMOTE CONTROL  
PROTOTYPE DEVELOPING  
DATA SYSTEMS  
CONSULTANT SERVICES

Boston Edison Company Boston, Massachusetts	*Newport News Shipbuilding & Drydock Company Newport News, Virginia	*Saginaw Steering Gear Div., General Motors Corp. Saginaw, Michigan
American Telephone & Telegraph Company Murray Hill, N. J.	General Electric Co. Schenectady, New York	Food Machinery Corporation San Jose, California
Georgia-Alabama Electric Power Co., Birmingham, Ala.	*Forrestal Research Labs. Princeton, New Jersey	Cordis Corporation Miami, Florida
*Preformed Line Products Co. Cleveland, Ohio	Ferro Corporation Cleveland, Ohio	A. O. Smith Corporation Milwaukee, Wisconsin
*Allis Chalmers Co. Milwaukee, Wisconsin	*S. & C. Electric Company Chicago, Illinois	Joy Manufacturing Corp. New Philadelphia, Ohio
*Westinghouse Electric Co. East Pittsburgh, Pa.	*International Harvester Co. Melrose Park, Illinois	*The Garrett Corp. AI Research Division Phoenix, Arizona
Westinghouse Electric Co. Trafford, Pa.	*International Harvester Co. Chicago, Illinois	Detroit Edison Corp. Detroit, Michigan
*Westinghouse Electric Co. Leater, Pa.	N. Y. Central Railroad Cleveland, Ohio	Southern Electric Service Co. Birmingham, Alabama
U. S. Army Ft. Belvoir, Virginia	*Falk Corporation Milwaukee, Wisconsin	*Ebasco Services, Inc. New York, New York
*U. S. Army Ft. Eustis, Virginia	*Phoenix Rheinrohr Duisburg, W. Germany	*Kansas City Power & Light Clinton, Missouri
U. S. Air Force Patrick AFB, Florida	*Verein Deutscher Eisenhüttenleute Dusseldorf, W. Germany	Scripps Clinic & Research Foundation La Jolla, California
*U. S. Navy Cutler, Maine	University of Berlin Berlin, W. Germany	*Chain Belt Company Milwaukee, Wisconsin
*U. S. Navy Philadelphia, Pa.	Okura & Co., Inc. New York, New York	Mixing Equipment Company Rochester, New York
Assoc. of Amer. Railroads Chicago, Illinois	Furukawa Electric Ltd. Nikko Copper Works, Japan	*Dana Corporation Ft. Wayne, Indiana
*Brewer Engineering Lab. Marion, Massachusetts	General Motors Corp. Allison Division Indianapolis, Indiana	Cooper-Bessemer Corp. Mt. Vernon, Ohio
*Link Belt Company Indianapolis, Indiana	*General Motors Corp. Research Center Warren, Michigan	Arizona State University Tempe, Arizona
General Electric Co. Pittsfield, Mass.	*B. F. Goodrich Co. Troy, Ohio	U. S. Army Engineers Vicksburg, Mississippi
*General Electric Co. Erie, Pennsylvania	*Lycoming Div., Avco Corp. Stratford, Connecticut	Diamond Chain Co. Indianapolis, Indiana
General Electric Co. Cincinnati, Ohio	Aro, Incorporated Tullahoma, Tennessee	*Ford Motor Company Livonia, Michigan
General Electric Co. Louisville, Kentucky	Phelps Dodge Corp. Douglas, Arizona	Philadelphia Gear Co. Philadelphia, Pennsylvania
General Electric Co. Philadelphia, Pa.		Sun Ship Company Philadelphia, Pennsylvania

\*Indicates repeat orders

# TRANSMITTERS

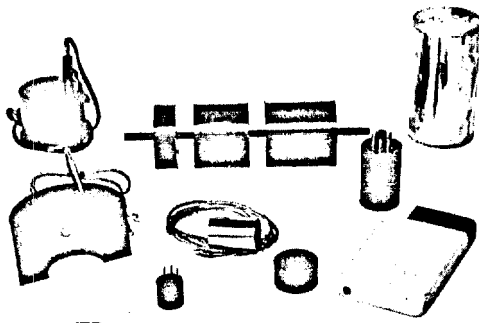

Various standard forms and sizes of telemetry transmitters and accessories are available. Our telemetry circuits may be cast in most any form required or may be cast in the test fixture itself. Write us of your requirements.

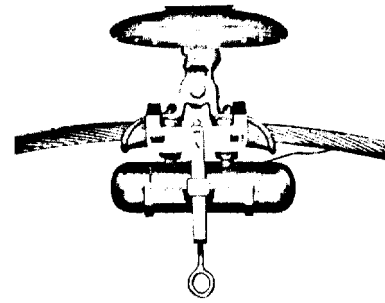

Transmitter in corona shield and weatherproof case for the measurement of vibratory strain and acceleration on high-voltage transmission lines to predict points of fatigue failure during high wind and icing conditions. Photo Courtesy of Preformed Line Products Co.

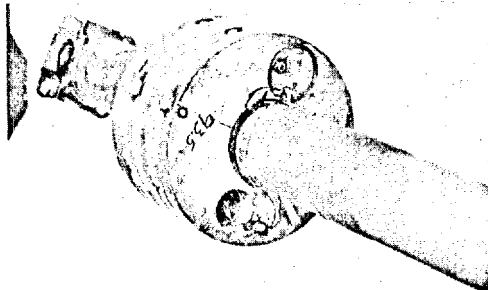

Drive Shaft 4 inches diameter. Instrumented for torque tests using T60 Transmitter.

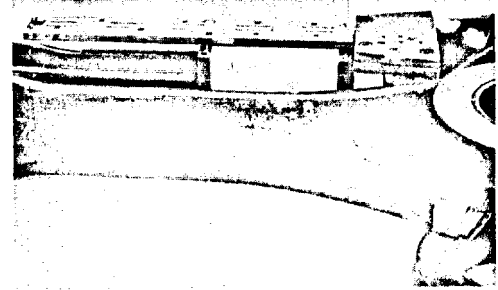

Subminiaturization of Transmitter permits mounting in confined areas with the transducer. Shown a Transmitter in the connecting rod of a diesel engine to measure temperature and strain during operation. Photo courtesy of General Electric Co.

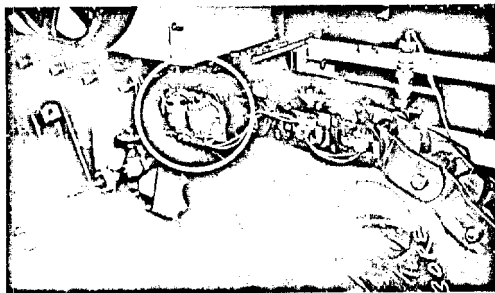

Application of subminiature T61 Transmitter for measurement of strain in links of a chain. Photo courtesy of Chain Belt Co.

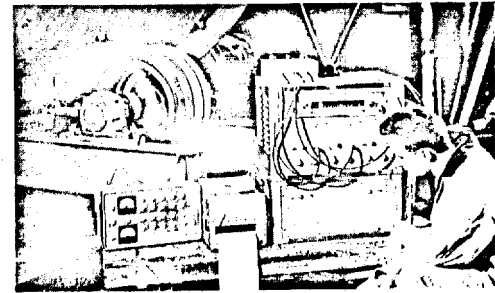

Measurement of strain in a Grinding Mill. Photo courtesy of Allis-Chalmers Manufacturing Co.

# RECEIVERS

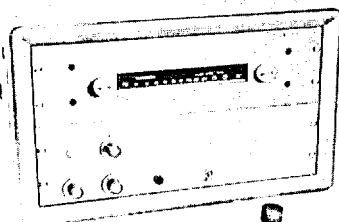

Model R61 Receiving Station with period controlled discriminator. Model R61 PL has Phase-Lock Discriminator. Transmitter Model T66 in foreground.

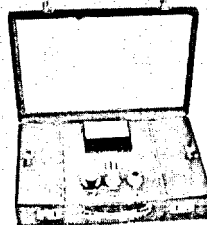

Model R69 Receiving Station. All solid state circuitry with self-contained re-chargeable batteries, timed battery charger and output indicating meter.

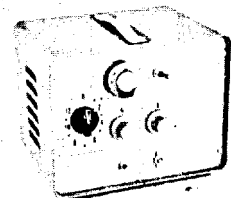

Model R70 Receiving Station. All solid state circuitry with self-contained re-chargeable batteries and timed battery charger.

## OTHER PRODUCTS

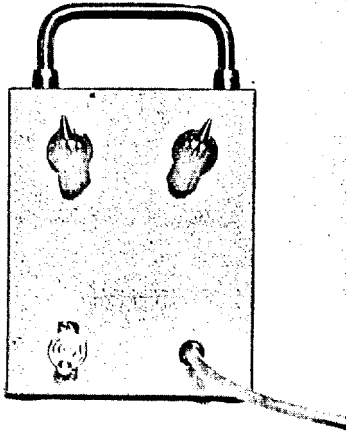

Model S-200 Strain Simulator Dynamic Calibrator is a resistance strain gage calibrator which permits step selection of resistance values in parallel with strain gage. Resistance is chopped in at frequencies from 10 cps to 3,000 cps. Five resistance steps are provided. Unit has self contained batteries.

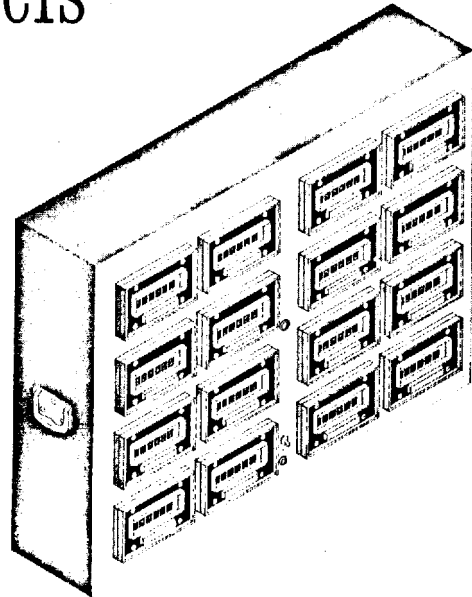

Model FA 62 Fatigue Analyzer. This instrument records the number of strain reversals through each of  $n$  preset levels or each of  $n+1$  adjacent levels or each of  $n+2$  adjacent levels, etc. Response is from 0 to 10 kc with input levels from 10 mv to 10v full scale.

## SERVICES (Design and Production)

Special Instruments or Systems. Remote Control Systems. Control and Shutdown. Proportional Control. Production.

Consultant Services in the fields of:  
Telemetry  
Data Acquisition and Processing  
Antennas  
RF Links and Systems  
Engineering Tests

---

## ORDERING INFORMATION

When requesting a quotation or placing an order please include the following:

1. Environmental conditions
2. Size or space limitations
3. Type of recorder to be used and input impedance
4. Transmission distance
5. Transducer employed and its resistance

Representatives are located throughout the United States and in many foreign countries. Your representative is: