

1960

RECORDS MANAGEMENT HANDBOOK

Managing Forms

FORMS ANALYSIS

Revised
May 1960

GENERAL SERVICES ADMINISTRATION
NATIONAL ARCHIVES AND RECORDS SERVICE
OFFICE OF RECORDS MANAGEMENT

RECORDS MANAGEMENT HANDBOOKS are developed by the National Archives and Records Service as technical guides to reducing and simplifying paperwork.

RECORDS MANAGEMENT HANDBOOKS:

Managing correspondence: <i>Plain Letters</i>	1955	47 p.
Managing correspondence: <i>Form Letters</i>	1954	33 p.
Managing correspondence: <i>Guide Letters</i>	1955	23 p.
Managing forms: <i>Forms Analysis</i>	1959	62 p.
Managing mail: <i>Agency Mail Operations</i>	1957	47 p.
Managing current files: <i>Protecting Vital Operating Records</i>	1958	19 p.
Managing noncurrent files: <i>Applying Records Schedules</i>	1956	23 p.
Managing noncurrent files: <i>Federal Records Centers</i>	1954	25 p.

CONTENTS

	PAGE
I. WHAT IS FORMS ANALYSIS?	1
II. WHOSE JOB IS IT?	2
III. CHALLENGING THE NEED	4
IV. READING THE FORM	13
V. WRITING THE FORM	20
VI. TRANSMITTING THE FORM	36
VII. FILING THE FORM	42
VIII. IMPROVING PROCEDURES THROUGH FORMS ANALYSIS	46
IX. TOOLS FOR THE ANALYST	51
CHECK LIST	62

1
Approved For Release 2001/07/17 : CIA-RDP74-00005R000100020026-4

Approved For Release 2001/07/17 : CIA-RDP74-00005R000100020026-4

I. WHAT IS FORMS ANALYSIS?

In the Federal Government generally all of us want a form which can be smoothly integrated into daily operations and help advance those operations rather than hinder them. We want the form to provide accurate and dependable information, readily accessible in our records—information we can rely upon as a sound basis for forming policy, making decisions, and directing or coordinating operations. We want a form which will improve employee morale and create public goodwill. We want a form which will be economical in manpower, equipment, and printing costs for its preparation and use.

This is what we want, but it is not what we always get. Instead, we often get forms that are hard to read and understand, difficult to fill in accurately, impossible to process quickly, uneconomical in size, and costly to print.

Why does this happen? Because so many of us take the attitude that a form is unimportant. We fail to realize that a form is actually an outline of a job to be done, a procedure in motion.

We get effective forms only through *forms analysis*. Forms analysis is the means of determining WHAT should go on the form. It is a specialized kind of methods improvement or procedural simplification, its approach to such improvement and simplification being through the forms involved. When we analyze a form in the light of its related work routines, possibilities arise for benefits which go beyond the specific actions of entering information on the form or taking information from it in some prescribed sequence. Forms analysis thus is management analysis applied in the *three* following areas:

● NECESSITY OF INFORMATION

The first important consideration is to question essentiality. Not all the information to be gathered always suits the service or process for which it is to be used. Sometimes different information would be more suitable and often less would be sufficient.

Many times the procedure requiring the use of the information also may be unnecessary in whole or in part. These aspects of forms analysis are covered in chapter III, *Challenge the Need*, and chapter VIII, *Improving Procedures Through Forms Analysis*.

● PREPARING THE INFORMATION

Analysis in this area is required to determine the best way of getting the information needed, the best method of minimizing error, the easiest way of entering information on the form, and the most convenient and economical method of sequencing it. In this handbook these aspects of forms analysis are covered in chapter IV, *Reading the Form*, and chapter V, *Writing the Form*.

● HANDLING THE INFORMATION

Processing the information calls for determining what equipment and methods will do the work best. The information must flow between two or more points, and speed and accuracy of flow can be hastened or slowed down by the way the form is developed. The information must always be retrievable at low cost and rapidly. These aspects of forms analysis are treated in chapter VI, *Transmitting the Form*, and chapter VII, *Filing the Form*.

II. WHOSE JOB IS IT?

The improvement of forms should be a cooperative effort of all those who create, fill in, use or otherwise handle forms. In practice, however, most improvements will come either from the office of the operating official who originates the form, or from a forms management analyst.

The reasons for this are not far to seek.

OPERATING OFFICIALS

Most forms have their beginning in the office of an operating official. He is the one who knows how "his form" is used and how its use affects other operations in the office. If a form is to be revised, he is the one who must decide which change is best and approve the final revision.

Operating officials, therefore, should know about useful methods of forms analysis and improvement. With this extra knowledge they should be able to "rough out" the content of a form that would meet the standards set forth in this handbook.

It is natural for the operating supervisor or administrator to feel that his everyday operating responsibilities are enough without worrying about the analysis and improvement of forms. A common reason given for delaying action on forms improvement is that operating problems take up all available time.

What many officials fail to notice is that unsuitable forms, or the need for more forms, actually bring about many of those operating problems. For example, much of the correspondence in some offices is caused by forms which are not clear as to the entries desired or the action to be taken. The official himself frequently spends much of his time on work involved in correcting mistakes and clarifying misunderstandings caused by unsuitable forms. Just releasing his time for other work should be sufficient incentive to improve his forms without even considering the time released for his people.

Then, too, some officials may not stop to consider that they are already studying forms

just to keep them current with changing operations and conditions. With just a little more study many changes could be developed into substantial improvements.

This is not to imply that the operating official should qualify himself to be a forms management analyst. That is never his primary responsibility. He should, however, be aware of the time he and his subordinates spend in studying forms to make changes and in handling operating problems caused by unsuitable forms or the need for forms.

If the time spent is substantial, he should certainly be concerned with making his efforts more effective, even if it means spending a little more time temporarily. It usually is a matter of taking time to save time.

FORMS ANALYSTS

The magnitude of the forms problem has warranted the establishment of a forms management staff in many agencies and bureaus. This staff assists operating officials particularly in the analysis of the more complex forms, and the ones which relate to others to establish a system.

In many instances, the staff is able to suggest further improvements which the originator did not think of. Partly this is because many forms branch out beyond the originating office into other organizational elements for their preparation or use. Even in substantive programs most of the forms are administrative in nature, where there are many similarities between organizational segments. The experience of the forms analyst includes a knowledge of standard (Government-wide) forms as well as agencywide practices.

The forms analyst can stand detached from the operating task and see procedural aspects which those closer to the operation may not see. Further, the analyst is in the best position to be a middleman between the originator and the users. Finally the forms analyst will usually be the forms designer, bringing the

viewpoint of that technical specialty to bear on the matter. But despite its skill, it would be a mistake to assume that the whole burden of forms analysis could ever be shifted to any forms management staff. There can scarcely be a substitute for the firsthand knowledge of operating officials in determining **WHAT** goes on the form.

CERTAIN ESSENTIALS

The earlier an analyst is requested to participate in the development or revision of a form the

more helpful his recommendations will be. Too many times the originator brings his rough sketch to the forms analyst and says: "This form must be at the print shop by tomorrow night." The analyst can't do a good job in that time.

It is the joint, cooperative effort of operating officials and forms analysts, during all phases of the development or revision of a form, which pays the greatest dividends in the improvement of forms and related procedures.

III. CHALLENGING THE NEED

Mr. "X" is a Division Chief. A change in the office procedure of one of his Branches requires that additional data be processed in that office. The Branch can get what it needs from 15 field offices of the agency.

The first impulse of the Branch Chief is to believe that the easiest way to secure the information and use it is by a new form. He hastens to get a blank sheet of paper and rapidly starts writing questions. He writes questions because about 95 percent of all forms are a kind of questionnaire.

He quickly decides he could use the answers to 20 questions. Put in forms language, he is talking about 20 spaces to be filled in. He determines, rather hurriedly, what should go on the form. He has become a forms originator.

But he has only started. He did not stop long enough to ask himself the right questions, nor did he take time to think through his replies.

Or consider another situation.

That same Branch has been using another form for three months. Three employees have told the Branch Chief the persons filling in item 17 apparently do not understand what is wanted. He has also been told by some of his staff that if two more facts were provided on the form, it would cut out "quite a few" letters for additional information and some teletype communications.

The Branch Chief did what you would expect. He decided to revise the form. He called for a copy of the form and with a few quick strokes of his pen he made the changes he wanted.

But before Mr. "X", the Division Chief, approves the sketches of his Branch Chief and initiates a new form or revises one already in use he should get his subordinate to ask the six questions shown in figure 1.

CHALLENGING THE NEED

1. Is the form needed enough to justify the work generated by its preparation and use?
2. Is each proposed item necessary?
3. Is each copy needed?
4. Can the form be combined with others?
5. Will the addition of another form, item, or copy simplify work?
6. Do the related procedures need revision?

Figure 1

CHALLENGE EACH FORM

To determine the necessity for a form, we must find out if the work generated by its preparation and use is justified.

First we must ask, "*What would we do if we didn't have the form?*" This question is designed to put the originator in a reasoning frame of mind. It will help to separate necessary information from that which would be just nice to know. It will force to the front other alternatives. One of them may be better than the proposed way.

We can eliminate a form if:

- The information is not needed
- Another source is available
- The cost of the information exceeds its worth

Information Not Needed

One surprising lesson to be learned from studying forms is the number of times information is being recorded which serves no important purpose. Perhaps at one time the information was essential but, because of changing conditions, it is no longer needed. This is an age of rapid

change. People originating forms, furthermore, are usually so busy with day-to-day operations that they have little time to examine their work objectively.

Another Source Available

Another surprising lesson from forms analysis is the number of times the same or similar information is being recorded or reported at more than one point in an organization. When there is such duplication of information, usually the information needed can be obtained from another *source*, from forms, records, or reports being used for other purposes.

This makes it possible to avoid creating a new form and the procedures related to it by relying upon information maintained elsewhere, by substituting a similar document or a copy of it which will serve the purpose, or by revising another document to make it acceptable in lieu of the form under study.

Finding a better way to obtain the information will permit the elimination of the form. Perhaps mechanical methods for compiling the information would be better and more economical than the manual procedures presently used. Perhaps the form can be eliminated, simply by using a rubber stamp.

Cost of Information Exceeds Worth

Seldom is the full cost of a form realized until a price tag is placed on its preparation and use. In most cases the principal costs are labor costs—the man-hours required to gather information, fill in the form, summarize or extract information from the form, and perform all the other related clerical and administrative tasks.

Frequently, costing a form has to be done item by item. When this is done, it identifies that part of the information which is more costly than the other parts.

Although one can usually estimate what a form costs, a determination of its worth is usually pure subjective judgment. By putting a price tag on a form and discussing it with others, it may be found that the costs are much greater than anticipated. Just the act of bringing to light the total cost of the form may cause

a re-evaluation and eliminate or reduce the information it contains.

In one agency, when the supervisor learned a form would cost \$200,000 he decided it was not worth it. In another agency a \$75,000 cost changed the supervisor's mind.

Of course, no one should attempt to cost every form, or the originator may find himself spending more time in costing than in developing improvements. Costs should be computed only when there is some reason to doubt that the information is worth what it appears to cost on the basis of workload data collected during the fact finding.

CHALLENGE EACH ITEM

The next thing to do in challenging the need is to challenge each item on the form. We follow much the same process used in challenging the entire form. "What would we do if we didn't have this item?" we ask first.

In one Government agency, a supervisor eliminated 4 man-months of punch card work per year by challenging the need for one item which called for entry of month, day, and year. The "day" entry was not needed.

We can eliminate the item if:

- It collects information which is no longer needed
- There is a better source or way for obtaining the information
- The information it collects costs more than it is worth
- It can be combined with another item

This challenging of items is an important part of forms improvement. It takes only a few minutes for each item, if a complete job of gathering the facts has been done. It is seldom that a form is subjected to a complete study without finding some items which can be eliminated or simplified.

The work necessary to enter one item on one form may not be too time consuming. But when the form is completed hundreds or thousands of times the work required for one item may represent many man-hours of employee time.

CHALLENGE EACH ITEM, EACH COPY

BEFORE

3650 (2/58)
by the Comptroller General.

**PUBLIC VOUCHER FOR REFUNDS
AND
FHA FEE APPRAISER DESIGNATION**

U.S. HOUSING AND HOME FINANCE AGENCY
FEDERAL HOUSING ADMINISTRATION

LOCATION (FHA Field Office City) X

Appropriation or Funds MMI (Sec. 203). If other, Insert Section of the Act. X

Name and Address X

AFTER

Federal Housing Administration

APPRAISAL ASSIGNMENT	Date Assigned	FHA Case No.	APPRAISER'S BILL TO MORTGAGEE
Name of Mortgagee			Date Appraisal Completed
PROPERTY LOCATION (Street and number, city, county, and State)			AMOUNT DUE: \$20.00
TO:			Signature of Fee Appraiser
TO THE MORTGAGEE: Your Credit Memo is attached. Please use FHA Case Number when making payment to Fee Appraiser.			FHA AUTHENTICATION Date Appraisal received by FHA and stamp or initials of authorized FHA Employee

The appraisal of the property described in the attached application has been assigned to you as an independent fee appraiser. Please complete the appraisal on the prescribed FHA form within three (3) days and send it to this office. Your fee for completion of an acceptable appraisal will be \$20.00 which will be paid to you by the Mortgagee. This form signed by you in the right hand column will constitute your bill to the Mortgagee and should be returned to FHA with the appraisal. FHA will note its receipt of the appraisal on the form and forward it to the Mortgagee as its authority to disburse your fee to you. If you cannot accept the appraisal and complete it promptly, CHECK HERE

1. Appraisal Assignment-Bill Copy (To Appraiser) FHA Form No. 3650 (Rev. 1/59)

Three Copies

RESULTS

- 18 items eliminated
- 4 copies eliminated

Voucher Certification

AUTHORIZED CERTIFYING OFFICER (Sign Original Only)

Distribution of Copies: 1 (original), 2 and 3 to FHA Comptroller, 4 and 5 to Fee Appraiser with case, 6 to Mortgagee as an advance notice, and No. 7 (last) in FHA Field Office Ticker File.

AUTHORIZED CERTIFYING OFFICER'S STAMP

1 ORIGINAL (TO COMPTROLLER)

Seven Copies

Figure 2

Figure 2 shows how the Federal Housing Administration eliminated 18 items from an 8" x 10½" form, enabling FHA to redesign it to an 8" x 3½" form. By cutting the size, three forms could be printed on an 8" x 10½" sheet, which further reduced by two-thirds the 250,000 times the form was inserted into the typewriter. Also, the number of copies was reduced from seven to three.

CHALLENGE EACH COPY

One of the biggest wastes in the paperwork of many organizations is the preparation of unnecessary copies of forms. Just the waste of paper and employee time in preparing these unneeded copies gives us reason enough to challenge each copy of every form.

More significant, however, is the time wasted by people who have to review copies which they did not need in the first place. Frequently these people are in responsible positions and can ill afford to spend time reviewing information they do not need.

Then too, everyone hates to discard filled in forms, and they usually wind up in files, even when the need for them is not too clear. In this manner unneeded copies waste the time of file clerks, squander costly file cabinets, and usurp valuable office space. Each file cabinet whose purchase can be avoided will save at least 6 square feet of floor space and \$60 or more in equipment cost. It takes only 12,000 copies of a form to fill an entire filing cabinet.

Sometimes when copies go to A, B, and C, it will be found that one copy instead of three may suffice by having that copy go to C via A and via B.

Sometimes three copies go to offices quite close to each other. They may be willing to cut out two copies once it has been decided where a single copy would be most accessible to all.

Sometimes copies are required for successive administrative echelons—one for the unit, one for the section, one for the branch, and one for the division. A division chief in a case like this should be asked if this could indicate overlapping of functions. If all four copies

are being filed the division chief needs to be reminded that each filing cabinet, when full, represents \$1,000 of clerical effort, \$1,000 of time to open file drawers and insert a piece of paper in the right spot.

COMBINE WHERE POSSIBLE

There are at least three ways in which forms can be advantageously combined. They should be combined, of course, when they can be, for this is usually the great "pay off" area in forms analysis. We combine forms for:

- Standardization
- Telling the whole story
- Filling in at one writing

Standardization

Similar forms are often used for essentially the same purpose in different parts of an organization. By getting the people responsible for these forms in agreement the development of *one form* may replace the others. Examples of this kind of combining are so common with established forms programs that many can be given.

Figure 3 is a typical case study. It comes from the Veterans Administration and shows how four request-for-information forms were combined. The task of the analyst here was to realize that despite differences in content, sequence and arrangement of items, methods used to obtain the information, and construction of the forms—still in essence they were kin.

Of course one benefit of this kind of combining is to reduce printing and stocking costs. Much more important, it brings about a selection of the best procedure for processing the form, reduces the training time of employees reassigned between offices, and simplifies direction.

Telling the Whole Story

A second way to combine is by consolidating forms used in successive work steps. This makes it possible to get the complete story on one sheet of paper. Frequently this avoids

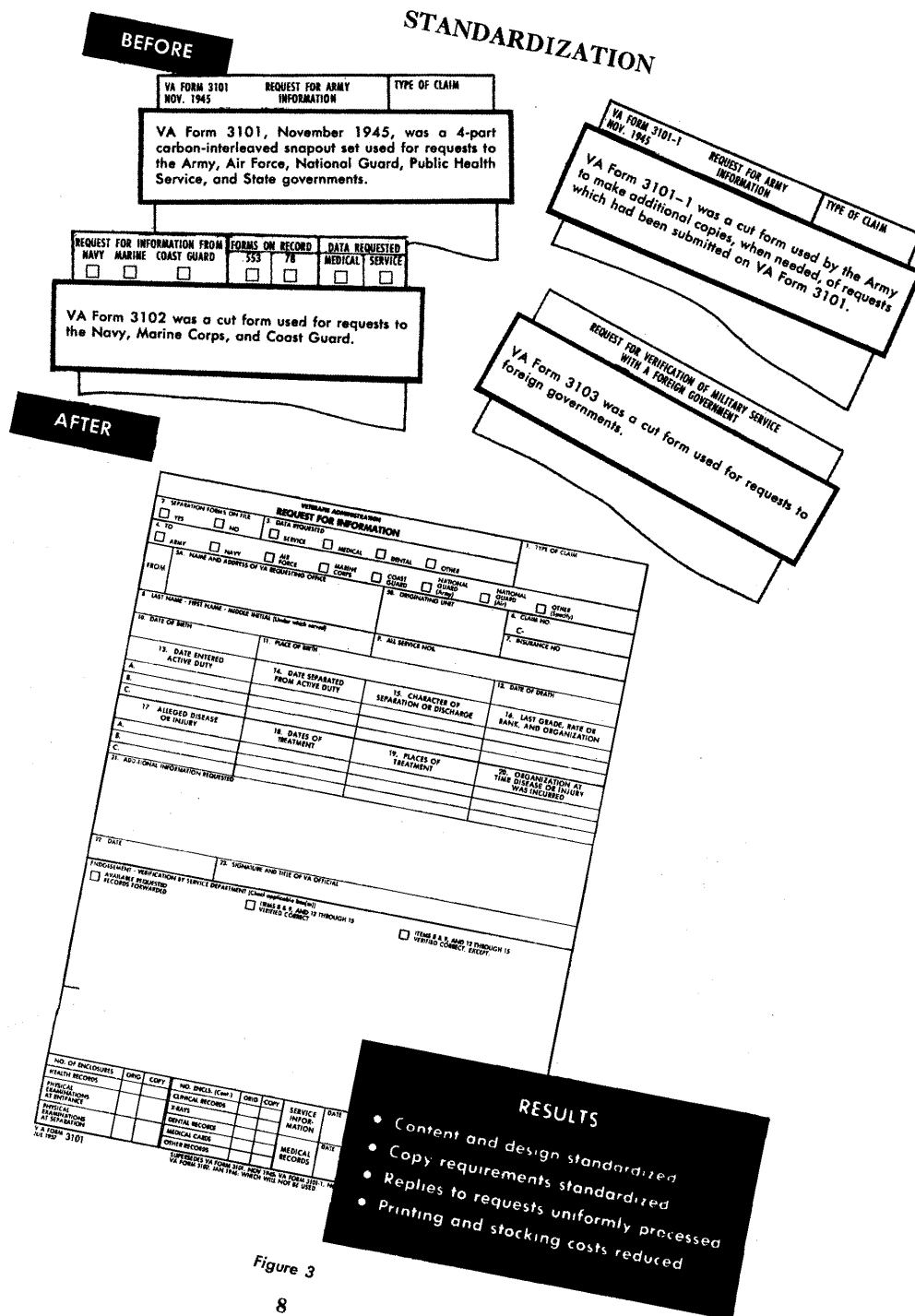

Figure 3

the transcribing of information from one form to another.

Even if transcribing is not eliminated, consolidation is still helpful. For example, an agency formerly used one form to request the reproduction of printed material. The next step, a request for the distribution of the material to the recipients, required another form. Much of the information entered on the reproduction request was also entered on the distribution request, so these two forms were replaced by a "Requisition for Reproduction and Distribution." Now this one form not only serves all purposes, but even better it also documents the whole continuous transaction. It tells the whole story.

"Telling the whole story" is portrayed further in the study made by the Department of Commerce. Eighteen different forms were used by the various bureaus within the Department to requisition different types of printing services including distribution and mailing. It was also learned that the billing information could be included on the requisition to eliminate additional paperwork. Figure 4 shows how the forms were combined and the procedure standardized.

Filling In at One Writing

The objective here is to get all information common to several forms into one writing operation. Usually this is accomplished by entering the common information on all forms, even though after they are filled in they are separated to serve different purposes and not all the information is needed at each location.

The appointment of Federal employees is handled by one form, although the payroll office and the Civil Service Commission copies could contain less information than is on the "original" copy. Yet, one typing is better than three even if two of the copies contain more information than the recipients require.

Figure 5 shows two form letters and two forms used by the Internal Revenue Service to process certain types of cases. Addressing these letters and forms required 1,800,000 initial typings. The name and address of the

taxpayer and the taxable year, however, was the key information that was being entered. This could be entered at one typing. This reduced the 1,800,000 typings to 450,000.

The advantages of combining forms in this way are increased clerical production, and decreased printing and stocking costs.

FILL FORM GAPS

Improving a form does not always mean simplifying or eliminating forms, items, or copies. Some operating difficulties have their origin in the need for another form, for items that are missing from a specific form, or for an additional copy.

So originators must be on the alert for any additions which will simplify work.

The need for additions often turns up during discussions with people working with the form. The need for other additions may become obvious after examination of individually composed letters or narrative reports requesting recurring data, and directives or manual issuances. The best method of finding missing items is to examine completed copies of a form in the files.

Analysts look for handwritten or typed notations for which space was not provided on the form. If the same basic notations appear repeatedly, chances are that the form should be revised to include space for such entries. A review of the procedure might reveal that by using an extra copy of the form unnecessary writing on the same form or possibly other forms can be eliminated.

A few forms attempt to do too much. A form should be designed to do a special job, and when it attempts to do more, operations will bog down. Where this is so, two forms would be better than one.

REVISING PROCEDURES

By challenging the facts we can determine if the form or items on it should be eliminated or combined, if missing items should be added, if the number of copies for each preparation should be reduced or increased, and the best

TELLING THE WHOLE STORY

BEFORE

18 forms eliminated

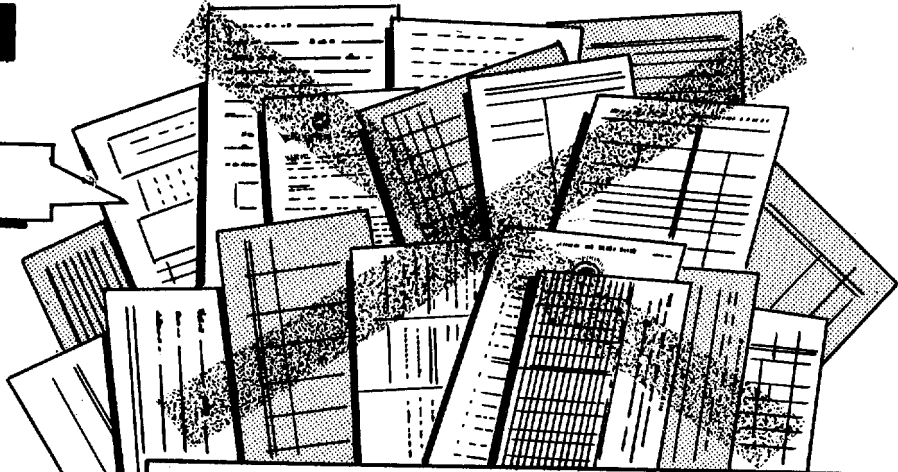

AFTER

Types of services

Mailing information

Distribution information

Billing information

BUREAUS - DO NOT WRITE IN SHADED AREAS

FORM CO 10 (10-3-59)		U. S. DEPARTMENT OF COMMERCE PRINTING REQUISITION		1. BUREAU	2. ORIGINATING OFFICE	3. REQUISITION NO.	
INSTRUCTIONS - Submit copies 1 through 4 to the Control Desk, Printing Division, Office of Publications Management.				4. DATE OF REQUISITION		5. REQUIRED DELIVERY DATE	
6. PERSON TO CONTACT FOR SUBJECT MATTER INFORMATION				CODE	EXTENSION		
8. TITLE OR DESCRIPTION OF JOB				9. JOB TO BE REPRODUCED IN <input type="checkbox"/> COMMERCE <input type="checkbox"/> GPO			
				10. FORM NO. (If any)			
11. CHARGE TO REQUISITIONING BUREAU FOR ANY OVERTIME WORK NECESSARY TO MEET DELIVERY DATE IS <input type="checkbox"/> AUTHORIZED <input type="checkbox"/> NOT AUTHORIZED				12. FORMS REPRINT - PERM. NEG. NO.			
13. SERVICE REQUIRED <input type="checkbox"/> FORMS PREPARATION <input type="checkbox"/> OFFSET COMPOSITION <input type="checkbox"/> DRAFTING <input type="checkbox"/> G. CREATING (Complete Item 30) <input type="checkbox"/> MAILING <input type="checkbox"/> OTHER (Specify in Item 32)				14. REPRODUCTION PROCESS <input type="checkbox"/> PHOTO-OFFSET <input type="checkbox"/> DIRECT IMAGE OFFSET <input type="checkbox"/> MINICODOGRAPH <input type="checkbox"/> PHOTOCOPY (Complete Item 15) <input type="checkbox"/> DUALID <input type="checkbox"/> OTHER (Specify in Item 32)			
15. PHOTOCOPY/PHOTOGRAPHS - COMMERCE PHOTO: <input type="checkbox"/> NEGATIVE <input type="checkbox"/> POSITIVE COPY: <input type="checkbox"/> PHOTO <input type="checkbox"/> GRAPH		16. NO. OF PROOFS GPO PAGE GALLEY		17. DAYS BUREAU TO HOLD PAGE GALLEY		18. GPO TO HOLD REPRODUCIBLES (Provide)	
19. TOTAL PAGES SUBMITTED MANUSCRIPT LITHOGRAPH HALFTONES		20. REPRODUCIBLES FURN. NEGATIVES PLATES		21. FINISHED PAGES NUMBER SIZE (Check which)		22. PRINT COPY <input type="checkbox"/> ONE SIDE ONLY <input type="checkbox"/> HEAD TO HEAD <input type="checkbox"/> HEAD TO FOOT <input type="checkbox"/> HEAD TO SIDE	
23. COVER STOCK (Color, blind, weight)		24. TEXT PAPER STOCK (Color, blind, weight)		25. NO. COPIES REQUIRED			
27. BINDING (Check which) <input type="checkbox"/> LEFT SIDE <input type="checkbox"/> SADDLE <input type="checkbox"/> FOLD AND PASTE <input type="checkbox"/> UPPER LEFT CORNER <input type="checkbox"/> ASSEMBLE ONLY <input type="checkbox"/> TRIM 4 SIDES <input type="checkbox"/> PERFORATE ON FOLD <input type="checkbox"/> OTHER (Specify in Item 32)							
28. PUNCHING (Indicate No. of holes - submit sample)				29. PADDING <input type="checkbox"/> TOP <input type="checkbox"/> SIDE			
30. ADDRESSING		ENVELOPES		TABBING		MAILING LIST SYMBOL NUMBER	
NUMBER OF SETS		LARGE SMALL SELF MAILERS				NUMBER ON LIST	
31. COPY DISTR.				DELIVER COMPLETED WORK TO BUILDING ROOM			
TOTAL DISTR.		BUREAU COST ESTIMATE		APPROPRIATION CHARGEABLE		CODE	
TOTAL STENCILS RUN		TOTAL PACKAGES		TOTAL PIECES ADDRESSED			
MAILING LIST MAINTENANCE DELETIONS ADDITIONS CORRECTIONS LABOR							
32. ADDITIONAL INFORMATION (Such as authorization for reproduction of copyrighted material.)							
33. SIGNATURE - AUTHORIZED OFFICIAL (Indicate Office)							
34. SIGNATURE - AUTHORIZED BUREAU REPRESENTATIVE							

1- DEPARTMENTAL PRINTING DIVISION

Figure 4

method for preparing copies. Then we are faced with the question of how the procedures related to the form should be revised to agree with changes which should be made in the form.

If the forms revision is minor, no general review of the procedure is called for. Even if the revision is major, a procedural study may

not be timely from the point of view of the originator or the analyst.

If a procedural review is called for, however, chapter VIII of this handbook gives helpful hints on how to collect facts and present them. As in the case of the form itself, we start out by challenging the essentiality of the procedure.

FILLING IN AT ONE WRITING

BEFORE

U.S. TREASURY DEPARTMENT
INTERNAL REVENUE SERVICE
DISTRICT DIRECTOR

IN REPLY REFER TO

Mr. John E. Doe
100 Main Street
Anywhere, U.S.A.

Taxable year ended 1960

FORM 2038 (REV. JAN. 1957)	U.S. TREASURY DEPARTMENT, INTERNAL REVENUE SERVICE INFORMATION TO SUPPORT EXEMPTION CLAIMED FOR DEPENDENT ON FEDERAL INCOME TAX RETURN	TAXABLE YEAR 1960
1. NAME OF DEPENDENT	NAME OF TAXPAYER John E. Doe	SYMBOLS

U.S. TREASURY DEPARTMENT
INTERNAL REVENUE SERVICE
WASHINGTON 25, D.C.

IN REPLY REFER TO

Mr. John E. Doe
100 Main Street
Anywhere, U.S.A.

In Re:
Year(s) 1960

U.S. TREASURY DEPARTMENT
INTERNAL REVENUE SERVICE
DISTRICT DIRECTOR

IN REPLY REFER TO

Mr. John E. Doe
100 Main Street
Anywhere, U.S.A.

TAXABLE YEAR 1960

(Name of Dependents)

- Prepared separately about 1,800,000 individual typings.

AFTER

U.S. TREASURY DEPARTMENT
INTERNAL REVENUE SERVICE
DISTRICT DIRECTOR

Mr. John E. Doe
100 Main Street
Anywhere, U.S.A.

1960
Taxable year

Your Federal Income Tax return for the year indicated above has been selected for examination. The additional information requested below is necessary before your deduction for dependent(s) can be allowed.

- Common data entered at one typing

RESULTS

1,350,000 fewer typings
of name, address and year

Figure 5

IV. READING THE FORM

Originating officials usually see only the operational role of a form—eliciting information. To them forms provide the framework to get data on income, place of birth, military service, naturalization, and employment. Forms document the movement of goods and constitute the contract for goods and services. They record payments and are the applications for loans, pensions, and other benefits. They mirror the financial accounts. This is their operational role.

To elicit this information, however, *words* are used on the blank form. Words are used in the title, indicating what the form is about; in the captions, telling what information is wanted; and in the instructions, directing the user how to enter the information. Forms analysis must throw a spotlight on those words if a useful form is to be developed.

To do this the originator should ask the six questions shown in figure 6.

READING THE FORM	
1.	Who will the reader be?
2.	Does the title most aptly indicate the purpose?
3.	Is the wording of the captions concise and clear?
4.	Is there any particular part which needs emphasizing?
5.	Are there any instructions to the user of the form outside the organization?
6.	Inside the organization?

Figure 6

THE READER

After looking at the lengthy, comprehensive form sent out under the Selective Service Act,

an exasperated "selectee" scrawled across the first page, "I am ready when do you want me," and returned it. How many public-use forms have been similarly disregarded by the recipients because they look "too complicated and too long" will never be known. Neither is it known how costly the subsequent followup has been.

Clearly the terminology of the questions on a form should be adapted to the type of person who will supply the information asked for. A form addressed to specialists familiar with a given subject matter can be technical, but the "man in the street" likes familiar words.

All of the words and phrases used should be familiar. Unfamiliar terms are "formfuzzy." For example, "delimiting deadline" can be changed to "date due." "Pay" would be better than "remuneration," and "home address" better than "domicile." "Before" is better than "prior to," while "after" is superior to "subsequent to." Throw away "hereto" and "herein."

Legal terms and technical jargon are especially suspect. In Government we get so used to them that it takes a deliberate effort to recall that other persons do not habitually use such language.

But forms also can have too few words. For instance, an item calling for "birthplace" can be answered in terms of home address, or city, county, and State or country. An amplifying statement placed after the item, such as "Birthplace (city and State)" tells the reader exactly what is wanted.

The amount of attention that must be given to the wording of questions on forms depends on whether figures, facts other than figures, or opinions are sought. The latter requires the most attention to wording.

TITLES

Every form should have a short, memorable title which should be as fully indicative as feasible of the purpose and function of the form. This type of title assists in identifying the form (as in an index) and gives the user a knowledge of its purpose at a glance. Furthermore, it aids the forms management office in effectively developing and using the functional file discussed in chapter IX.

Form titles should be built around a keyword which indicates the function of the form. Keywords such as *card*, *sheet*, and *blank* ought to be avoided. They refer to the physical character of the form, not its usage. Figure 8 is a list of the principal keywords used in form titles, and the purpose which the form would be expected to serve, if its title included the word indicated. The notations are not definitions.

Form titles, in addition to a good key noun, should be backed up by a complete and descriptive group of adjectives. They should be as brief as possible. Examples of complete vs. incomplete titling are:

<i>Incomplete</i>	<i>Complete</i>
Account of property.....	Excess Personal Property Report.
Work Sheet.....	Reproduction and Printing Work List.
Funds Estimate.....	Personal Services Funds Estimate.
Inventory Card.....	Office Supplies Inventory Notice.
Weekly Backlog Slip..	Weekly Personnel Action Backlog Summary.

The analysis of an incomplete title versus a complete title further demonstrates the value of keywords and how they tie in with the functional filing of forms. For example: Does the title "Account of Property" accurately describe the use of a form which is used to report an excess of items such as work uniforms, gloves, hats, etc.? These items are classified as personal property. Here the keyword is "report," which means the purpose of the form is "to make an account of action or status." The words "ex-

cess personal property" describe what is to be accounted for to make the report. Thus, a better title would be "Excess Personal Property Report."

This title would also aid the forms analyst to functionally classify the form. The keyword "report" ties in with the action performed "to report," and could be cross-indexed "to account."

Figure 8 is a useful compendium of the key words most commonly used in titling forms.

CLEAR AND CONCISE CAPTIONS

Most forms ask questions. But to save words and therefore save space, the questions usually aren't written out. Instead of asking, "What is your age?" it is better simply to say "Age." The question mark is understood. Instead of "Where were you born?" the statement "Birthplace (city and State)" is better. Captions worded in this manner save reading time, are more readable, and thereby facilitate entering the desired information.

The diagram illustrates the mapping between questions and form fields. Arrows point from the following questions to their respective fields in the form below:

- "What is your age?" points to the AGE field.
- "On what date were you born?" points to the BIRTHDATE field.
- "In what town and state or foreign country were you born?" points to the BIRTHPLACE (CITY, STATE) field.
- "In what professional societies, if any, do you hold membership?" points to the MEMBERSHIP IN PROFESSIONAL SOCIETIES field.
- "Are you a citizen of the United States?" points to the U.S. CITIZEN field.

AGE	BIRTHDATE	BIRTHPLACE (CITY, STATE)	U.S. CITIZEN
			<input type="checkbox"/> YES <input type="checkbox"/> NO
MEMBERSHIP IN PROFESSIONAL SOCIETIES			

Figure 7

To assure that copy is clear a preliminary tryout on a sample of potential users often proves helpful. A few of the most common faults are pointed out on page 16.

KEYWORDS IN TITLING FORMS

KEYWORD	PURPOSE OF FORM	KEYWORD	PURPOSE OF FORM
Abstract	to make a summary of	Notification	a written or printed document by which information is sent
Account	to record debit and credit	Order	to command
Acknowledgment	to document the receipt of	Pass	to permit to go and come
Affidavit	to attest the truth of	Payroll	to list persons receiving pay, as for wages
Agreement	to offer and accept in writing	Permit	to authorize a specific act
Allotment	to distribute in portions	Petition	to request formally
Appeal	to request the review of a decision	Questionnaire	to ask questions to obtain data
Application	to request something	Receipt	to acknowledge delivery or payment
Appointment	to constitute	Recommendation	to advise on course of action
Assignment	to specify	Record	to retain an account of facts or events
Authorization	to permit an action	Register	to list events or actions in some sequence
Award	to bestow	Release	to set free
Bid	to offer for a price	Report	to make an account of action or status
Bill	to itemize	Request	to ask for
Bond	to issue interest-bearing certificate	Requisition	to apply for formally
Cancellation	to revoke	Return	to report on income and outgo of funds
Certificate	to verify the truth of	Roll	to register events
Claim	to ask as due	Roster	to list names
Commission	to grant powers	Routing	to direct documents from one office or individual to another
Communication	to interchange information	Schedule	to catalog recurring events; to publish a plan of future action; to append
Complaint	to formally allege	Specification	to state requirements; to particularize in detail
Contract	to agree to provide for a price	Statement	to communicate a declaration or report
Deed	to convey real estate	Summary	to contain the substance of a fuller account; to brief
Diary	to record daily	Survey	to inspect; to examine and report on condition and value
Digest	to classify and condense	Tabulation	to arrange in a systematic outline, usually in columns
Document	to furnish information	Telegram	to convey a written message by telegraph
Endorsement	to write; to assign	Ticket	to attach to goods, giving information on nomenclature, size or price; to entitle the holder to specified privileges
Estimate	to calculate approximately	Transmittal	to send out an attachment
Follow-up	to seek completion of an action	Transcript	to provide a written copy
Guide	to direct the course	Voucher	to bear witness; to receipt for payment
Identification	to name	Warrant	to guarantee anything; to answer for the genuineness of
Index	to list		
Inquiry	to seek to know		
Instruction	furnish with direction		
Inventory	to itemize		
Invoice	to bill or charge for		
Itinerary	to record a trip		
Journal	to record daily transactions and status		
Lease	to rent		
Ledger	to record fiscal accounts		
List	to catalog, enroll, or register		
Log	to record daily progress		
Manifest	to list cargo		
Memorandum	to record informally		
Memorial	to keep in mind		
Message	to communicate		
Note	to assist the memory; to acknowledge a debt		
Notice	to announce information or directions		

Figure 8

Too Many Clauses

Questions containing long dependent or conditional clauses tend to confuse the reader even though he understands the words. In trying to comprehend the questions as a whole, he may overlook or forget a clause; hence his answer may be incomplete or wrong. Figure 9 shows how this analysis can be done.

BEFORE			
"List amount of any refund check(s) which are returned for cancellation, also include the amount of any refund checks which were returned unclaimed and date(s) check(s) returned."			
AFTER			
REFUND CHECKS RETURNED			
FOR CANCELLATION		UNCLAIMED	
AMOUNT	DATE RET.	AMOUNT	DATE RET.

Figure 9

Excess Words

Space is at a premium on a form, and it must be used wisely. Therefore the number of words must be counted and the "contract awarded to the low bidder." Consider this "Before" and "After." The Before has 38 words; the After has 15.

BEFORE			
Number of employees on payroll for work-week ended nearest March 15	Payroll for the work-week ended nearest March 15	Number of employees on payroll for work-week ended nearest July 15	Payroll for the work-week ended nearest July 15
AFTER			
WORKWEEK ENDED NEAREST			
MARCH 15		JULY 15	
NUMBER OF EMPLOYEES	PAYROLL	NUMBER OF EMPLOYEES	PAYROLL

Figure 10

More Than One Point at a Time

Multiple questions should be avoided. Unless each question covers only one point, there will be confusion as to the point actually referred to. Multiple questions should be broken down into two or more questions so that separate answers can be secured. Figure 11 illustrates this point.

BEFORE	
QUESTIONS	
1. If this is the corporation's first return, indicate whether (a) completely new business <input type="checkbox"/> , or (b) successor to previously existing business, which was organized as (1) corporation <input type="checkbox"/> , (2) partnership <input type="checkbox"/> , or (3) sole proprietorship <input type="checkbox"/> , or (4) other (indicate) _____ If successor to previously existing business, give name and address of the previous business organization _____	
AFTER	
ADDITIONAL INFORMATION REQUIRED	
1. Is this the corporation's first return? . . . <input type="checkbox"/> Yes <input type="checkbox"/> No	
2. If "Yes," check whether—	
(a) <input type="checkbox"/> completely new business, or	
(b) <input type="checkbox"/> successor to previously existing business, which was organized as	
(1) <input type="checkbox"/> a corporation,	
(2) <input type="checkbox"/> a partnership,	
(3) <input type="checkbox"/> sole proprietorship, or	
(4) <input type="checkbox"/> other (indicate) _____	
3. If successor to previously existing business, give name and address of the previous business organization.	

Figure 11

EMPHASIS

A form cannot be designed most effectively for easy reading until it is determined whether any particular part needs to be highlighted.

Type faces can be used to direct the reader, get attention, or signal important information. For example, on certain enumerating forms used by the Census Bureau the questions to be asked by the enumerator were printed in bold face type; instructions to and observations to be made by the enumerator were printed in light face type. Figure 12 illustrates this.

INSTRUCTIONS

Most forms *need* instructions. The reader must often be told how to fill in certain items, the number of copies required, and when and where each is to be sent. These instructions, plus other essential guidance, can usually go on the form in a self-explanatory way.

Inside the Organization

Complex forms usually cannot be made self-explanatory. They require detailed instructions. These should be published in directives, manuals, and other administrative issuances along with a "specimen" copy of the form keying the instructions to the items to be filled in. The reason for this is cost. It is usually less expensive to print instructions in an issuance system than to place them on the form. This is particularly true of large-usage forms.

The most serious problems arising from poor prescribing instructions arise in the field. If the issuance is not clear and complete, autonomous field offices might revise a prescribed form or devise one of their own to replace it.

The originator is in the best position to make form and instructional material mesh perfectly. He not only drafts the rough sketch of the form he proposes, but he generally drafts the prescribing issuance. In many organizations the originator sends the form draft to the forms management office and the instruction draft to an administrative procedures office. The two should not part. The forms office should get a copy of the instruction, and the administrative procedures office should get a copy of the final version of the form.

Originators doing forms analysis disregard the preparation of the related instructional material at their own peril. They reap the difficulties sown through inadequate directives, inadequate in their wording and inadequate in their visual presentation.

Outside the Organization

Extended general and specific instructions needed for public-use forms can be printed on the back of the form, or on a separate sheet or in a booklet. How they are written and presented graphically aids in the readers' interpretation of the form and the accuracy of the fill-in. Where instructions are lengthy the rules to be found in the Records Management Handbook, *Plain Letters*, should be helpful.

The principal barriers to clarity in the instructions prepared for the forms user outside the organization are these:

- Words not appropriately chosen
- Main point buried in a welter of words
- Meaning made a riddle by undue brevity
- Meaning obscured by faulty sentence structure

The "before" part of figure 15 shows an instruction for filling in a form that is not keyed to item numbers. Note how difficult it is to correlate the instruction with the form depicted in the middle. Note how the "after" part makes that correlation easy simply by keying the instruction to items on the form. The widespread failure to do this is one of the basic faults of much instructional material.

IMPROVING INSTRUCTIONS

BEFORE

ENTER A CHECK MARK IN THE PERMANENT TOTAL BOX FOR AND TOTALLY INCAPACITATES A PERSON FROM FOLLOWING
 ENTER A CHECK MARK IN THE PERMANENT PARTIAL BOX IN THE LOSS OF ANY MEMBER OR PART OF A MEMBER OF IMPAIRMENT OF FUNCTIONS OF THE BODY OR PART THEREOF PERMANENT DISABILITY.
 ENTER A CHECK MARK IN THE TEMPORARY TOTAL BOX AND WHICH RENDERS THE INJURED PERSON UNABLE TO PERFORM ANY DAY OR SHIFT SUBSEQUENT TO THE DAY OF THE INJU AND DAYS OFF).
 ENTER A CHECK MARK IN THE TEMPORARY PARTIAL BOX THE INJURED PERSON FROM PERFORMING HIS OWN JOB ON OF INJURY, BUT DOES NOT PREVENT HIS PERFORMING AN ANY INJURY WHICH REQUIRES MEDICAL TREATMENT ONLY SHOULD BE CHECKED IN THE "FIRST AID" BOX.

- *Instructions not keyed to items on form*
- *Type difficult to read*

AFTER

Section III—RELATED DATA			
OTHER		(3) PERMANENT TOTAL	(4) TEMPORARY PARTIAL
(1) OTHER FEDERAL AGENCY PERSONNEL	(2) NONFEDERAL PERSON	(5) PERMANENT PARTIAL	(6) FIRST AID

Section III

Item (3)—Any injury which permanently and totally keeps a person from following any gainful occupation.

Item (6)—Any injury which requires medical treatment only and does not result in loss of time.

- *Instructions keyed to items on form*
- *Instructions easier to read*

Figure 15

V. WRITING THE FORM

A common definition of a form is "a piece of paper containing static data onto which must be *written* variable data." Certainly a good form should be easy to fill in.

Analysis of all fill-in aspects of a form can be accomplished by the originator asking the 19 questions listed in figure 16. This analysis will:

- Guarantee the minimum chance of error in copying information to or from related documents
- Require a minimum of writing to complete the form
- Make the writing flow from left to right
- Make it flow from top to bottom
- Start as many lines as possible from the left margin
- Permit a continuous completion of the form with a minimum of hand or typewriter carriage travel from item to item
- Suit the requirements and take full advantage of time-saving features of any machines to be used for fill-in
- Align vertical rules for minimum typewriter tab stops
- Make sure there is enough space for each written entry—but not too much
- Fit vertical spacing to the writing method

The answers to the 19 questions can be pulled together under the headings of (1) arrangement, (2) spacing, and (3) construction. The rest of this chapter is organized under these headings.

WRITING THE FORM

1. Who writes the form?
2. Where is it written?
3. How much will the writer handle it?
4. Does the writer spend full time or part time writing form?
5. What is the best sequence and grouping of items for ease of filling-in and extracting information?
6. What is the approximate amount of information to be placed in each entry space?
7. What is the approximate number of lines in the body of the form?
8. Can questions be worded so that the answer can be simply an "X" mark?
9. Are there recurring fill-in data which can be preprinted?
10. What is the annual usage?
11. At how many points will the form be written?
12. How many copies are to be made at one writing?
13. Are more copies needed than can be obtained by using multiple copies combined in one set?
14. If a reproducible master is needed for additional copies, can it be included in the unit set or continuous form?
15. If a reproducible master is needed, what kind will fit available duplicating equipment?
16. After the form is initially filled in, will there be subsequent writing on the form?
17. Are there any related forms containing common data which can be written at the same time?
18. Is there any use of rubber stamps, or other stamping devices?
19. If a number of forms are combined for one writing, will certain data not be needed on the under copies?

Figure 16

MAKING WRITING EASIER THROUGH ARRANGEMENT

There is one best arrangement of the items on a form that is more logical, from the point of view of filling them in, than any other arrangement. It is the task of analysis to discover this one best way.

Item Grouping

Many forms take more time than necessary for their completion and use because the fill-in items are scattered over the working area of the form. This is particularly true of forms and form letters which are printed in narrative or text style, with spaces left at numerous spots in the text for the respondent to fill in the data and complete the text.

A much better arrangement is to place as many as possible of the fill-in items in one group on the form and revise the text to make it clear what is needed for each item in the group. This reduces the travel and positioning of the hand or typewriter carriage in completing the form and reduces eye movement in finding the items for extraction or review.

Frequently a form moves from one person or office to another, and some of the items are filled in at each stop. If the items can be grouped in separate sections for each person or office, time will be saved all down the line.

Completing a form arranged in sections is much easier than trying to follow instructions which read, "Office A will complete items 1, 5, 7, 21, etc." This principle is illustrated in figure 17.

When forms are printed on two sides, it is a writing help if all fill-ins can be placed on one side and all the instructional material put on the reverse.

Item Sequence

Also important to the speed of entering or extracting data is the sequence of the items on the form. Hand movement is reduced to a minimum when:

- The order of the items on the form corresponds to the order of the items on the document from which the information is taken.
- The sequence of the items on the form corresponds to the order of the items on the document to which information is posted.
- Information entered on the form corresponds to visual habits. People are in the habit of reading from left to right and from top to bottom. They are also accustomed to seeing related items arranged in familiar sequences. For example, address is usually requested in this order: number, street, city, zone, and State.
- The sequence of items follows the flow of work, and therefore the habitual way of thinking about matters in an office.

The best plan is to arrange items in all related documents in the same order. If this cannot be done, a careful analysis should determine whether the order of entry or the order of extraction of information is more important in terms of administrative difficulties and manpower usage.

The speed of entering and extracting data becomes particularly important in highly repetitive operations. Here it is helpful to arrange items across the form in frequency-of-use sequence as depicted in figure 18. Items which are always written should be first, and if there are any which are not always written, they should be located to the right of the form according to the percentage of times that the item is called for.

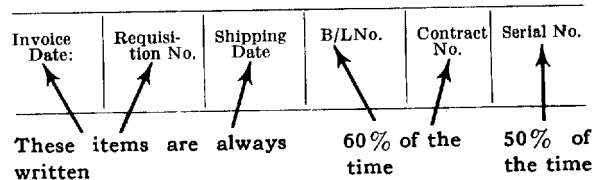

Figure 18

When forms are used as source documents for punching tabulating machine cards, the items should be arranged on the form in proper punching sequence. Figure 17 shows how the sequence of information on a form can correspond to that punched on a tab card.

Answer Boxes for "X" Entries

Originators of forms should be aware that one of the ways of reducing the amount of writing needed to fill in a form is through use of check boxes. In addition to reducing writing, check boxes (sometimes called ballot boxes) also:

- Save writing space
- Provide interpreting data
- Provide uniform answers
- Save time in extracting data
- Reduce the tendency to error

The "X" type of entry should be used when a selection can be made from definite optional answers, or when a question may be answered "yes" or "no."

For example: which is better?

- a. List diseases you have had in last 5 years
-
-

- b. Diseases you have had in last 5 years
(Place "X" in proper box)

- | | |
|-------------------------------------|------------------------------------|
| <input type="checkbox"/> Cholera | <input type="checkbox"/> Kidney |
| <input type="checkbox"/> Diphtheria | <input type="checkbox"/> Measles |
| <input type="checkbox"/> Heart | <input type="checkbox"/> Pneumonia |

In "a." the person filling in the form must search his memory for the answer. In "b." the form helps him search his memory, "jogs" it, and saves him having to write more than a simple "X" in the correct boxes. Also it would probably get more complete results, and with uniformity of nomenclature. This makes the information more usable at the extracting end.

Check boxes can also be used to combine forms. This occurs when the forms are very similar but used for different purposes. Check boxes can be placed at the top of the form as

EMPLOYEE PASS OR BADGE REPLACEMENT RECORD		
<input type="checkbox"/> PASSES <input type="checkbox"/> BADGES		
NUMBER	NAME	CANCELLATION DATE

Figure 19

depicted in figure 19 to permit the user to designate the purpose for which the form is used.

Check boxes are particularly useful in "check lists," as the one at the end of this Handbook

One agency had a 7-page questionnaire which was printed on one side of the page only and was assembled into sets. An analysis of the use led to the substitution of the answer box technique for the write-in method. This change reduced the form to one page printed front and back. This one technique reduced the number of printing impressions 71 percent, no assembly of sheets was necessary, and the bulk mailing charge was reduced 63 percent. In addition, of course, there was only one piece of paper to handle and process instead of the seven originally used.

Preprinting Fill-In Data

Another means of reducing the writing required is to plan for preprinting on the form those answers or parts of answers which will be used by everyone completing the form. A very simple example is the appropriation symbol. Some appropriation forms are revised each year as new appropriations for funds are approved. Preprinting the appropriation symbol on these yearly forms can reduce the typing required to complete the form by as much as 5 percent. Figure 20 depicts this principle.

TOTAL AMOUNT ORDERED \$	TOTAL SHIPPED
PAY TO: GENERAL SERVICES ADMINISTRATION OFFICE OF THE REGIONAL COMPTROLLER	POSTAL
	FREIGHT
	TOTAL AMOUNT BILLED
FUND TO BE CREDITED: 47X4530 GENERAL SUPPLY FUND	ACCOUNT
	SYMBOL

Figure 20

Spacing to Improve Writing

How many times have users been brought to a halt, in the midst of completing a form, by an item with too little space for the information

asked for? With some forms, too, the typist spends as much time with her hands on the platen knobs adjusting the typewriter to the spacing of the forms as she spends typing. These are signs of improperly spaced forms.

The originator of a form usually will know whether the form will be filled in by hand or by machine, and whether there will be subsequent writings. If the form is to be filled in by typewriter or other machine, the spacing throughout the form should permit full utilization of the time saving features of the machine. If it is to be completed by hand, sufficient space is needed for manual entries. The amount of space needed depends upon the conditions under which the form is written. To illustrate, a form written by a person sitting at a desk requires less space than one written by a person standing on a loading platform balancing a

clipboard in his hand. If the form is to be completed by hand, by typewriter, or by other mechanical devices the spacing must accommodate all methods used.

Computing Space Needs

Each item on a form will require a maximum number of letters, figures, and punctuation marks to be entered on the form. Each column on a form will require a maximum number of writing lines. A review of previously completed forms in the file will help to determine these maximums. *The originator's rough sketch should indicate the maximum fill-in for each item.* The "before" portion of Figure 21 shows how to indicate space needs on the originator's rough draft. The "after" portion shows how the analyst translates this fill-in information into workable space.

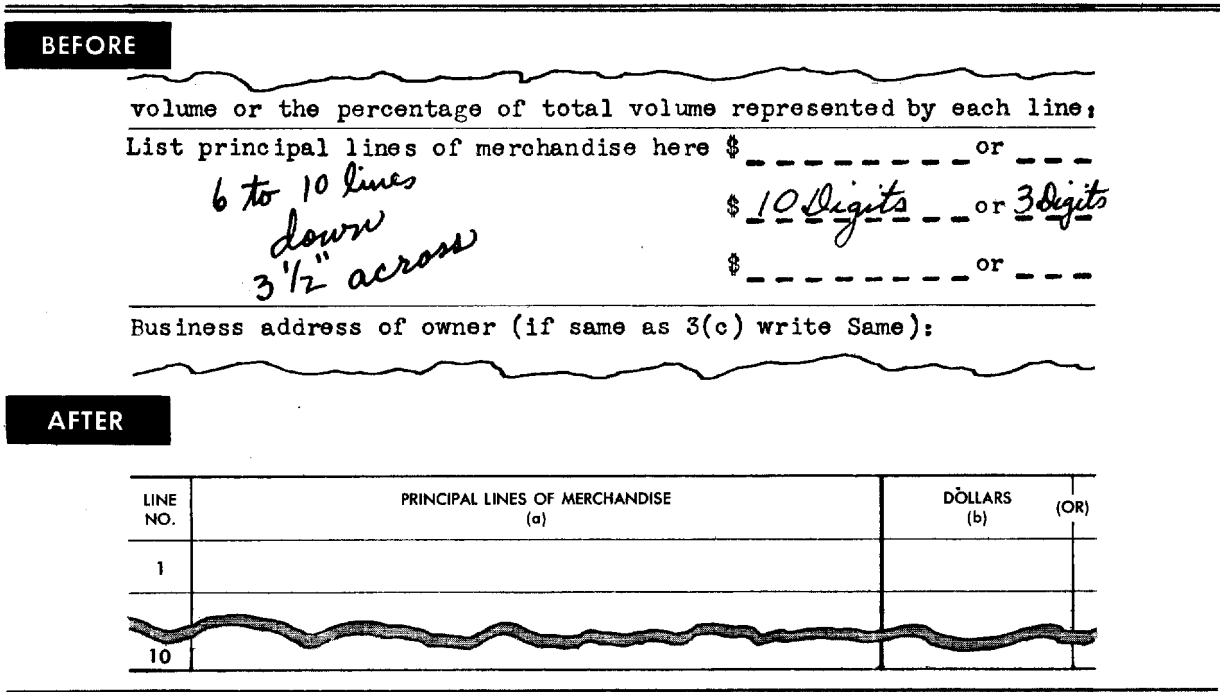

Figure 21

Box Design

With this style of design the caption and entry space for each item or question on the form are included in a box. Captions are printed in small distinct type in the upper-left corners of the boxes. This leaves the entire width of the box free for fill-in. It provides more space for

each item in less overall space. See the "before" and "after" illustration in figure 22.

Box design is practical for both handwritten and typewritten forms. It makes the vertical alignment of items easier and helps improve the appearance of forms. It facilitates typewriter fill-in by increasing the use of the typewriter

BEFORE

- Captions on line require typist to space through the printed words to typing position.

TO ASSISTANT REGIONAL COMMISSIONER,
ALCOHOL AND TOBACCO TAX _____, 19____

(City) (State)

The undersigned holder of Permit No. _____ to _____
(Manufacture or deal in)

Specially Denatured Alcohol at _____
(City or Town) (Zone)

(Street and number)

(State)

_____ makes application for permit to export _____
_____ packages of specially denatured alcohol _____, containing _____
Nos. _____

wine gallons, Formula No. _____
(Name of consignee)

located at _____
(Street and number) (City) (Foreign country)

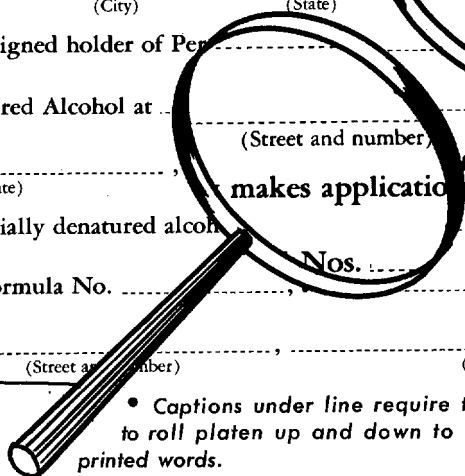

- Captions under line require typist to roll platen up and down to read printed words.

AFTER

TO Assistant Regional Commissioner, Alcohol and Tobacco Tax (City and State)		2. DATE
The undersigned holder of permit indicates that he makes application for permit to export specially denatured alcohol as set forth herein.		
3. NO. OF PRESENT PERMITS	4. PRESENT PERMIT IS TO (Check applicable box) <input type="checkbox"/> MANUFACTURE OF SPECIALLY DENATURED ALCOHOL <input type="checkbox"/> DEAL IN SPECIALLY DENATURED ALCOHOL	
5. LOCATION OF PERMIT COVERED BY PERMIT INDICATED IN ITEM 3 (No. and street, city or town, zone, State)		
6. NO. PKGS. EXPORTED	7. SERIAL NO. (City, foreign country)	8. NO. WINE GALS. TO BE EXPORTED
9. FORMULA NO.		11. CONSIGNEE IS ENGAGED IN BUSINESS OF (Describe)
12. IS CONSIGNEE ENGAGED IN BUSINESS OF MANUFACTURING OR DEALING IN SPECIALLY DENATURED ALCOHOL UNDER THE LAWS OF HIS COUNTRY? (Check applicable box) <input type="checkbox"/> YES <input type="checkbox"/> NO		

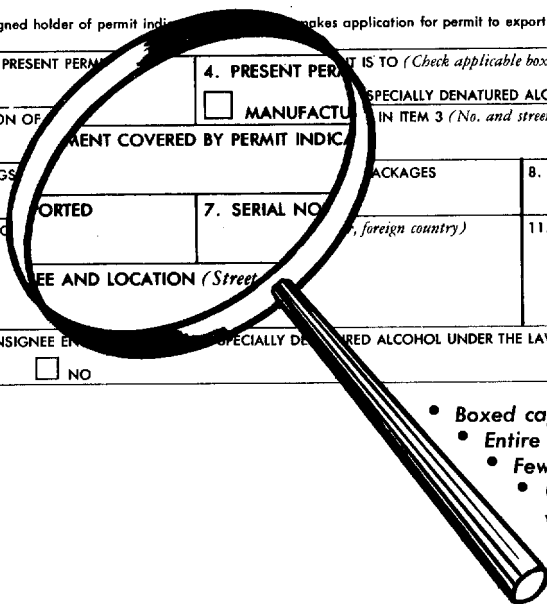

- Boxed captions visible for typing entry.
- Entire width of box free for answer.
- Fewer typing positions needed.
- Clearer association of captions with fill-in area.
- Helps appearance.

Figure 22

tabular key and by making each caption visible when the item is in position for typing the entry.

From figure 22 it can be seen that box design is superior to the "caption on the line" style because fewer typing positions are needed. For example, note how box design in the "after" part of the illustration uses the left margin as the starting position for all entries beginning on the left of the form. Captions on the line require numerous starting positions on the left depending upon the length of the individual captions.

From figure 22 it will also be noted that box design is much superior to the "caption under the line" style. The visibility of captions in the upper corner of boxes permits the typist to read them without rolling the typewriter platen up and down as is required when the captions are below the line. Every time a typist has to stop typing and hand position the carriage it

takes 12 times as long as a single keyboard stroke.

Columnar or Tabular Spacing

Box design should not be used indiscriminately. For some types of forms where it is advantageous to have a straight line computation, it is more practical to use a columnar or tabular arrangement. Such an arrangement is most beneficial when figures are to be added or subtracted. Figure 23 depicts columnar arrangement.

FORMS CONSTRUCTION TO IMPROVE WRITING

The single sheet is the most widely used form. It can be filled in by machine or hand and can be printed on any size and weight of paper and in any color of ink. It is economical and fast to print.

TO	There was procured or on order by this matter bearing official mailing indicia in the			
MATTER BEARING MAILING INDICIA (A)	GENERAL SERVICES ADMINISTRATION CONTRACT (Federal Supply Schedule) (B)	GOVERNMENT PRINTING OFFICE (C)	LOCALLY PREPARED OR PROCURED (Not from GPO or GSA contract) (D)	MAILINGS BY SUPERINTENDENT OF DOCUMENTS GPO (E)
ENVELOPES—SMALL (Not over 4½" x 10¾")				
ENVELOPES—LARGE (Over 4½" x 10¾")				
LABELS				
WRAPPERS				
CARDS				
TAGS				
OTHER ARTICLES				
TOTAL				
REMARKS				

Figure 23

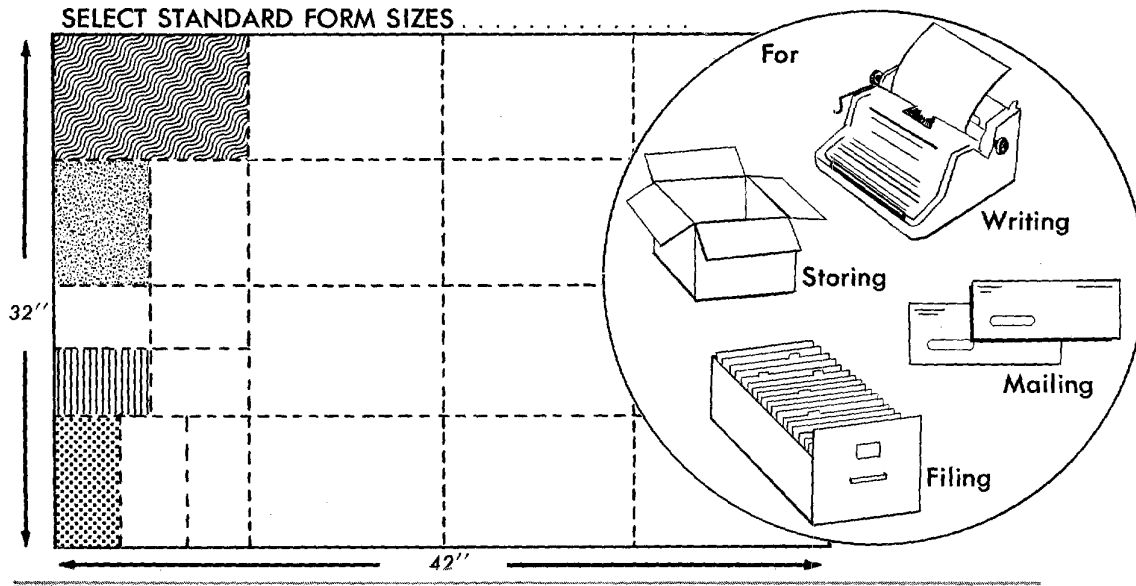

Figure 24

Sizes

The size selected should fit the writing method. Standard sizes based on the 8'' x 10½'' sheet or its multiples fit into standard typewriters and present no problems in printing, mailing, filing, shipping, and storing. If the form measures less than 8'' x 10½'' it should be cut out of an 8'' x 10½'' sheet in even segments without waste. See figure 24.

Folding and Perforating

Single sheets of paper perforated can be folded to make a variety of duplicate or triplicate copy sets, as indicated in figure 25. This provides a unit construction which makes the form easier to write. The carbon is inserted at the time of use.

Consider folding and perforating IF:

Duplicate or triplicate copy is the identical size. A sheet of paper can be folded at the top, bottom, or side and perforated on the fold for easy separation. This holds the forms in registration.

Duplicate copy is different size. The form can be folded and perforated so either the original or duplicate is the short form.

Triplicate copies vary in size. The sheet can be folded so that one copy is larger and two are the same size, or one copy is smaller and two are the same size.

Consider perforating IF:

- Writing can be done faster by having several forms printed on a continuous sheet (gang printing) with perforations between forms for easy separation for

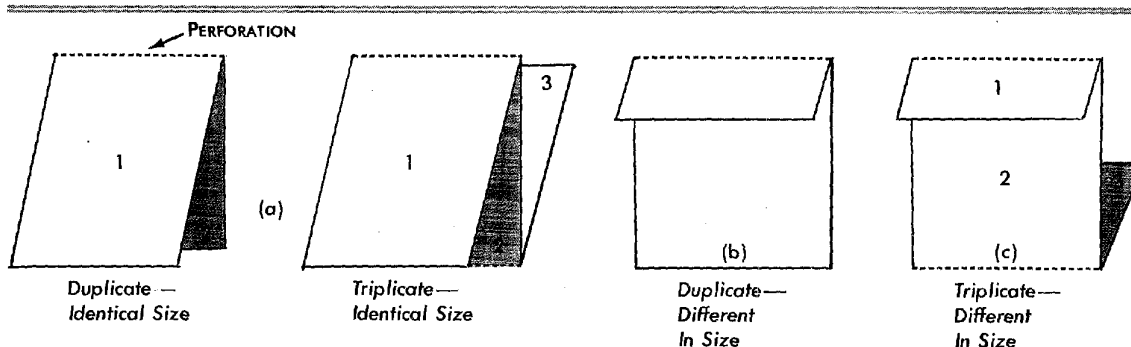

Figure 25

processing. See figure 26 for an example of a gang printed perforated form.

- All writing can be done on one sheet, after which the sheet can be separated into parts for processing, as shown in figure 27.

Padding

Another way of improving writing is to bind groups of forms together so that either single sheets or a set can be detached without dis-

FASTER WRITING BY USING GANG PRINTING

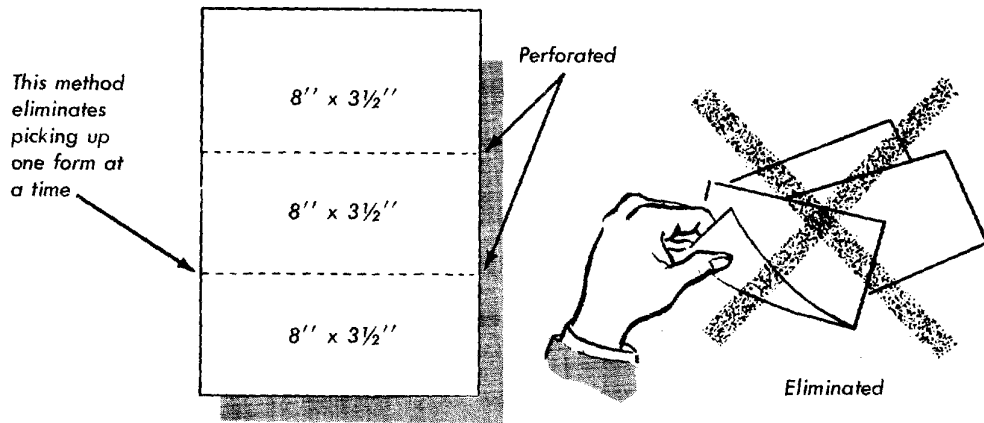

Figure 26

FASTER WRITING BY USING FOLDS AND PERFORATIONS

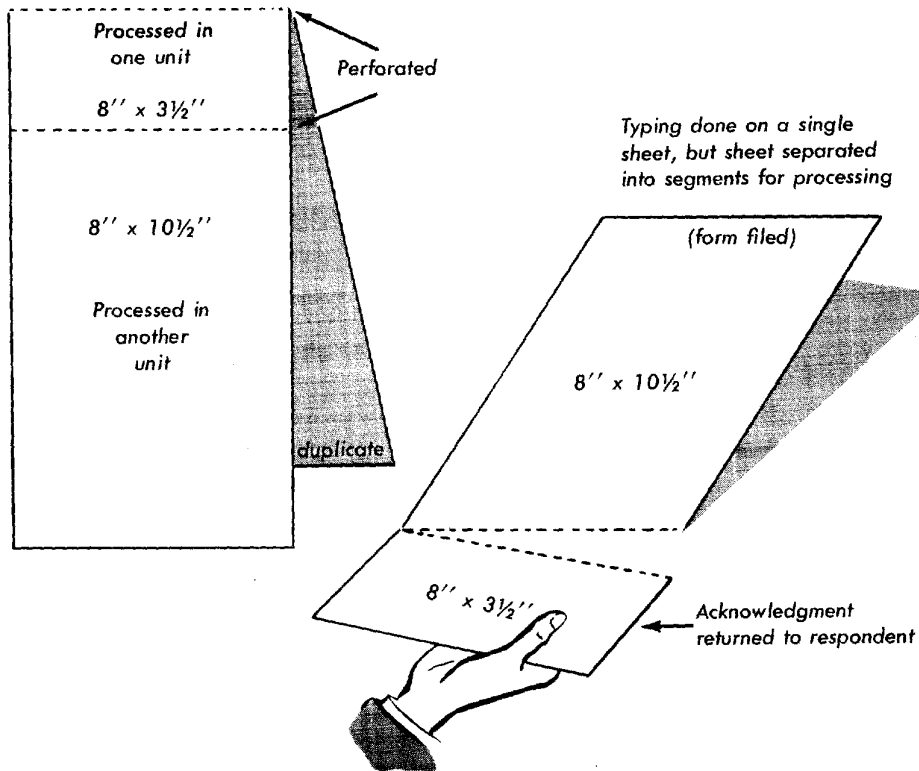

Figure 27

turbing the remaining forms in the pad. If forms must be printed on different colors of paper and usage does not justify a specialty-type form, padding the different colors in sets eliminates stocking the same form in various colors. This saves storage space and time in requisitioning and distribution. Padded forms are handy if a person must have available at all times a small supply of forms for a specific purpose.

Consider padding forms IF:

Carbon insertion is made easier. Padding keeps forms in alignment, especially if forms are handwritten.

Form is carried from place to place.

Padding prevents the loss and wrinkling of cut forms. The chipboard backing supplies a writing surface when needed.

Different colors of paper are needed for routing and sorting. Forms can be assembled into sets and padded when printed.

Portion of the form is retained. When receipt stubs are needed, the form can be perforated so that the stubs can be left in the pad until all forms or sets are written.

When forms have small daily usage at a single point, caution should be exercised in padding forms. If the user needs only a few copies of a form he should not be issued a pad of 25, 50, or 100.

SPECIALTY FORMS

The term "specialty" form is often used synonymously with "manifold" form, a term in turn meaning "multiple" copy. However, the term "specialty" applies not only to multiple copy forms, such as unit sets and continuous sets, but also to any type of form which requires special equipment for its manufacture, such as die-impressed and form-topped stencils, hectograph and offset masters, and any special die-cut, carbon-interleaved or perforated forms.

Generally these forms, particularly multiple copy forms, are manufactured on high speed rotary presses which can accommodate one or more full rolls of paper at one time. Such presses can prenumber, collate, perforate, and print in more than one color simultaneously and are not found in agency printing plants.

The use of multiple copy forms, stencils, and masters overcomes the problem of handling

loose forms and loose carbons. Their use eliminates such unproductive clerical operations as inserting carbons, jogging forms into alignment, inserting the set in the typewriter, aligning and rolling to the first line, and then, after writing, removing the set from the machine and removing the carbon sheets from between the forms. The use of a specialty form should be considered when:

- A large quantity of the same form must be written in multiple copies at one place. The type of construction that will do the job best and most economically must be chosen. For example, if 50,000 sets are written annually and 1,000 sets are written at 50 different points, this is a potential "unit set" application. But if 50,000 sets are written annually at one point, and if one or more clerks are spending full time in writing them, this is a potential "continuous" form application. If more copies are needed than can be obtained from a multiple copy form, a stencil, hectograph, or offset master should be considered.
- Several copies of the same form must be prepared simultaneously, but certain information is to appear only on selected copies.
- Locked in mechanical control of a duplicate record is needed for auditing, security, or other purposes, as in an autographic register.
- When office machines such as tabulating equipment and teletypewriters are required, a specialty form must be used to obtain maximum utilization.

Understandably, the cost per thousand of specialty forms is higher than that of cut (single sheet) forms. When specialty forms are properly used, however, the additional cost is not only compensated for, but outstanding clerical cost reductions are possible in processing the forms.

The subject of specialty forms is too long, detailed, and technical a subject to be treated in this handbook. It will be covered later, therefore, in a separate Records Management Handbook. Meanwhile, the analysis guides contained in figures 28 and 29 can be of assistance in selecting the type of specialty form best suited to a particular operation.

FORMS ANALYSIS GUIDE FOR MULTIPLE COPY WRITING— SPECIALTY FORMS





UNIT SETS	
<div style="text-align: center;">    </div> <p style="margin-top: 10px;">Form can be written with—</p> <ul style="list-style-type: none"> Pencil Ballpoint pen Typewriters Billing machines Addressing machines Accounting machines Fuel meters Printing scales Timeclocks 	<p><i>Consider if—</i></p> <ul style="list-style-type: none"> • Form is hand or machine written <i>WHY—</i> Eliminates inserting and jogging of carbons. Keeps forms in alignment. • Different copies of form are routed to different places Facilitates identification by permitting the assembling of various colors of paper into one unit. • Two or more forms have common data which can be written in one writing Combines forms of varying widths and lengths. Combines forms of varying paper weights. • Later entries are made Keeps set or part of a set as a unit for later entries and handling. • Selective information is needed on some parts and not on others Permits the deleting of information on subsequent parts by spot or strip carbon, varying widths and lengths of carbon, or preprinted blockouts. <hr style="border-top: 1px dashed black;"/> <p><i>Remember—</i></p> <ul style="list-style-type: none"> • Not economical for low usage forms. <p>For example—If the annual quantity is 50,000 sets and 1,000 sets are written annually at each of 50 points, this is a potential unit set application. However, if the annual quantity is 50,000 sets, written at one point, consider a continuous form.</p>
PADDED ONE-PART UNIT SETS	
<div style="text-align: center;">  </div> <p style="margin-top: 10px;">Form can be written the same way as unit sets.</p>	<p><i>Consider if—</i></p> <ul style="list-style-type: none"> • Form is written in a number of copies— (1) beyond the unit set (2) which vary from time to time <i>Why—</i> Permits flexibility in the number of copies written. <hr style="border-top: 1px dashed black;"/> <p><i>Remember—</i></p> <ul style="list-style-type: none"> • Does not permit combining different forms for one writing. • All copies must be the same paper weight as each sheet might serve as the original.

Figure 28

CONTINUOUS FORMS—MARGINALLY PUNCHED

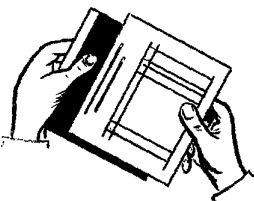
(Have same general features as unit sets)

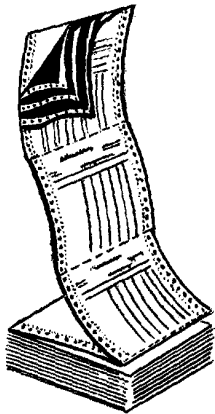

Forms can be written with—
 Typewriters
 Billing machines
 Addressing machines
 Teletype machines
 Integrated data processors
 Electronic data processors

Consider if—

Why—

- Machine on which form is written uses an aligning or feeding device Permits accurate registration from part-to-part and from set-to-set across and down the form.
- Size can be reduced through the close registration of copies which permits single instead of double typewriter spacing Reduces printing and processing costs.

Permits a continuous flow of sets through writing machine.

Remember—

- Usually impractical unless the forms are used in large quantities in a continuous writing operation.
- *Marginal punched continuous strip forms* are used to advantage when various parts must be different weights, grades or colors of paper.
- *Marginal punched fanfold forms* are used when the same weight and grade of paper is specified for all parts, or when parts and carbons must remain together for later entries. Side-tie perforations hold forms together without staples, clips or pins.

CONTINUOUS FORMS—NOT MARGINALLY PUNCHED

(Have same general features as unit sets)

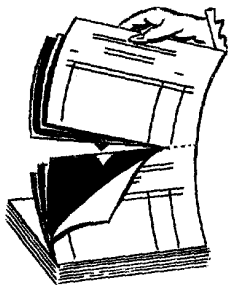

Form can be written with—
 Typewriters
 Billing machines

Consider if—

Why—

- Machine on which form is written does not have forms aligning or feeding device, but a large quantity of form is written Permits continuous flow of sets of forms through the writing machine.
- Permits easy movement of form from one typewriter to the other or from one place to the other.

Remember—

- Forms can slip during typing and realignment will be necessary.
- There are continuous forms available without carbon, but the writing machine must be equipped with a carbon shifter device.

Figure 28—Continued

SALESBOOKS	
 <p>Form can be written with— Pencil Ballpoint pen</p>	<p><i>Consider if—</i></p> <ul style="list-style-type: none"> • Form is handwritten Simplifies inserting carbons. Keeps forms in alignment. Eliminates inserting and jogging carbons. • Form is carried from place to place . . . Prevents the loss and wrinkling of forms. • Form will receive rough handling Keeps top form clean. Prevents dog-eared sheets. • Later entries are made Keeps set as a unit for later entries and handling. • Portion of form is retained Keeps receipt stubs or file copies in book until all sets are written. <hr style="border-top: 1px dashed black;"/> <p><i>Remember—</i></p> <ul style="list-style-type: none"> • Book cover must be inserted to prevent the writing from coming through on more copies than intended, or • Last copy of each set must be on sufficient heavy stock to prevent writing from coming through on more copies than intended.
AUTOGRAPHIC REGISTER FORMS (Have same general features as continuous forms)	
 <p>Form can be written with— Pencil Ballpoint pen</p>	<p><i>Consider if—</i></p> <ul style="list-style-type: none"> • Form is handwritten Fastest method of handwriting forms. Keeps papers and carbons ready for writing. • Prenumbered forms are needed for control purposes Assures positive control of audit or other internal copies. Retains control copy in filing compartment in register. <hr style="border-top: 1px dashed black;"/> <p><i>Remember—</i></p> <ul style="list-style-type: none"> • The volume used at one point should be sufficient to justify the use of the machine.

Figure 28—Continued

CARBONLESS PAPER

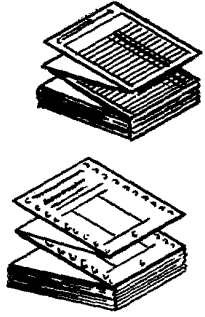
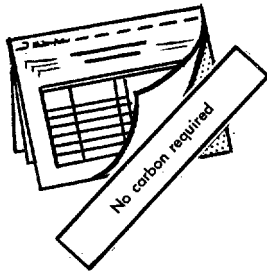

Form can be written
with—

Pencil
Ballpoint pen
Typewriters
Billing machines
Addressing machines
Accounting machines

Consider if—

- Carbon use or disposal is a problem.

Why—

Eliminates carbon paper
Eliminates carbon smudged hands or
clothing.

Remember —

- Erasures are hard to make.
- Number of copies written is limited.
- If additional entries are made on copies which have been placed one on top of the other, cardboard should be inserted between the sheets to prevent the transferring of entries to succeeding pages.
- Cost of carbonless paper is higher than paper and carbon paper.

Figure 28—Continued

FORMS ANALYSIS GUIDE FOR MULTIPLE COPY WRITING— DUPLICATE MASTERS

MASTERS	
Kinds—	
<p>OFFSET</p> <div style="text-align: center; margin: 10px 0;">  </div>	<p><i>Consider if</i></p> <ul style="list-style-type: none"> • Form is hand or machine written Eliminates repetitive writing. <p style="text-align: right; margin-right: 20px;"><i>Why—</i></p> <p style="text-align: right;">Reproduces from one writing common data applicable to a number of forms of various sizes and weights of paper.</p> <p style="text-align: right;">Reproduces from one writing more copies than can be obtained from a specialty form, but master can be a part of the specialty form.</p> <ul style="list-style-type: none"> • Later entries are to be made Permits the addition of data from time to time or at a different location.
<p>HECTOGRAPH</p> <div style="text-align: center; margin: 10px 0;">  </div>	<ul style="list-style-type: none"> • Data are to be eliminated Permits the eliminating of data. <hr style="border-top: 1px dashed black;"/> <p><i>Remember—</i></p> <p>OFFSET</p> <ul style="list-style-type: none"> • When masters are stored for reuse they should be treated with a preservative. In certain instances it is more economical to make a master from a master than to use a preservative. Master from master can eliminate future rewrites. • When the master is used to reproduce common data on more than one record the master <i>must</i> register with all preprinted forms used in the system. • To check availability of duplicating equipment. <p>HECTOGRAPH</p> <ul style="list-style-type: none"> • Writing-surface must be firm when handwritten. • Some types of masters soil hands and clothing. • Under certain conditions copies have a tendency to fade. • Master can be stored indefinitely but the carbon deteriorates. • When the master is used to reproduce common data on more than one record the master <i>must</i> register with all preprinted forms used in the system. • To check availability of duplicating equipment.
<p>Form can be written with—</p> <ul style="list-style-type: none"> Pencil Ballpoint pen Typewriter Addressograph machine Numbering machine Any other writing machine 	

Figure 29

STENCILS

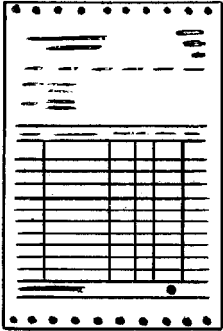
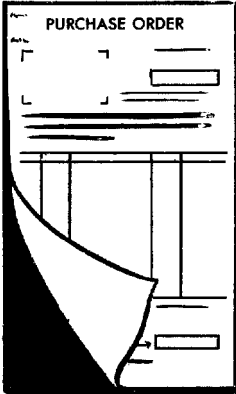
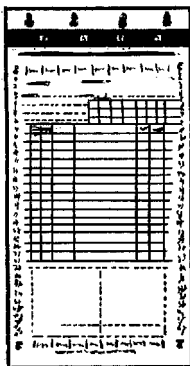

Form can be written with—
Typewriter

Consider if—

- Form is typewritten

Why—

Has the writing advantages of the offset or hectograph master, but cannot be included as part of a specialty form.

Remember—

- Quick drying ink should be used when forms are printed on sulphite paper.
- Additional entries cannot be made after the initial writing has been duplicated.
- When the stencil is used to reproduce common data on more than one record the stencil must register with all preprinted forms used in the system.
- To check availability of equipment.

NOTE.—The form may be printed on the master or stencil so that only the filled in data are reproduced on preprinted forms; or so both the form and filled in data are reproduced on blank paper.

Figure 29—Continued

VI. TRANSMITTING THE FORM

Form transmittal can be a simple process of routing an individual form through an agency. It can also involve many different forms and accompanying papers in large quantities, and thus entail a complicated dispatching program. Whether the operation is simple or complex, the results of forms analysis can help speed the process.

To give the transmittal phase of forms analysis its due, the ten questions shown in figure 30 need to be asked. The answers to the first six involve routing features while the last four pertain to dispatching factors.

TRANSMITTING THE FORM	
1.	Can self-routing information be printed on the form?
2.	If the form is routed to more than one person or office, what is the standard routing sequence?
3.	Can check boxes be used to reduce the amount of routing information to be entered?
4.	Can office symbols be used for routing?
5.	Will the use of colored paper help in the distribution of filled-in forms?
6.	Will some copies be held together for routing?
7.	How many accompanying papers are to be mailed with the form? <ol style="list-style-type: none"> Instructions for filling in Return envelope Additional forms Stuffers
8.	How is the form addressed for dispatching? <ol style="list-style-type: none"> Typewriter Addressing machine—right side Addressing machine—left side Mailing slip or label By hand
9.	Can a window envelope be used?
10.	Can self-mailing be used?

Figure 30

ROUTING

Routing information, showing "to" and "from," can be built into many forms. This permits economies to be achieved in a tangible way by eliminating routing slips, transmittal memorandums, or letters of transmittal. It also permits intangible benefits by saving the time of officials and clerical personnel through their having fewer papers to handle.

Forms that can be preaddressed should be, so that the mail room can sort for direct delivery to the action desk. This will make for more prompt delivery and less work for mail clerks and messengers. In many instances it may even be unnecessary for the mail room to open the envelope if the address is sufficiently detailed. An example is shown in figure 31.

TO	Department of Veterans Benefits Veterans Administration Central Office Washington 25, D.C. ATTN: Reports and Statistics Service Office of Controller
----	--

Figure 31

Forms should be preaddressed for routing purposes, if possible, when two or more offices have to see the same form in sequence. A standard routing sequence permits preprinting the routing information as illustrated in figure 32. When self-routing information is preprinted on the form, care should be taken to see that the routing sequence is the same as the flow of the papers.

REQUEST FOR REPLENISHMENT OF FORM OR FORM LETTER				
TO (Route in order)	1	Eastern Publications Depot	BUILDING	ROOM NO.
	2	Publications Control Officer	BUILDING	ROOM NO.
	3	Forms Control Staff <input type="checkbox"/> AAA <input type="checkbox"/> DM&S <input type="checkbox"/> DVB <input type="checkbox"/> INS.	BUILDING	ROOM NO.
	4	Eastern Publications Depot		

Figure 32

Check boxes can sometimes be used to reduce the amount of routing information that has to be entered. The less data that have to be added to the form as separate entries, the simpler the paperwork. Check boxes help when there is a definite and limited number of addresses. In these cases the printed routing information, such as the name of a division or section, should be general. The example in figure 33 illustrates this point.

VETERANS ADMINISTRATION—GOVERNMENT LIFE INSURANCE NOTICE OF LATE PREMIUM PAYMENT	
FROM (<i>Veterans Administration Office checked below</i>)	
<input type="checkbox"/>	Veterans Administration District Office Fort Snelling, St. Paul 11, Minnesota
<input type="checkbox"/>	Veterans Administration Insurance Center Munitions Building, Washington 25, D.C.

Figure 33

Office Symbols

Office symbols are usually abbreviations for names of organizations within the agency. They are useful as references, in designating messenger delivery stops, and particularly for routers in indicating routing information. Agencies use various kinds of symbols composed of either numbers, letters, or combinations of both. While symbols composed of key letters of office titles are best because of their mnemonic features, any office symbol that is short and simple will serve the purpose. Examples of symbols are given in figure 34.

Numeric or Alphabetic Symbols	Office of
00 A	Head of Agency
001 AA	Deputy Head of Agency
01 P	Chief of Personnel
11 PO	Placement Officer
02 M	Chief of Management
21 MR	Records Management Officer
25 MS	Research and Statistics Officer
26 MO	Organization and Methods Officer
261 MOA	Analyst

Figure 34

The use of different colored paper for copies of the form can sometimes aid in distributing the form. It will do so if a large number of

forms of multiple-copy construction are written, sorted, and routed at one spot. If, for example, a three-part purchase form is to be forwarded in each instance to three separate offices, then it becomes a matter of habit to send the white copy to the procurement office, the yellow copy to the receiving office, and the pink copy to the comptroller's office. Color, therefore, can be built into the form as a predominating factor not only for distribution but also for records disposal at a later time. If the pink copy becomes the ten-year retention record, the yellow can be designated for 6 months retention, and the white for 3 years. If the use of colored paper is not practical, copy identification may be built into the form by other means. It only requires a little additional printing in the bottom margin of each part of the form.

If some copies have to be held together for routing, the analysis should identify such requirements. The form can then be designed to allow certain parts to remain together for additional data to be inserted at subsequent stages.

DISPATCHING

Complete forms analysis will not only take routing requirements into account but also dispatching processes. Nearly every type of form is handled at one or more points in the agency mail and messenger system or in the postal system. Therefore, a mailing plan is a must.

The mailing plan is affected by the type of form under consideration. Conversely, the kind of form to be used may be determined on the basis of the mailing plan that is available. Consequently, the mailing plan should take into account certain questions pertaining to mail operations and, in addition, other matters permitting the use of such labor saving devices as addressing, collating, folding, and inserting machines. Finally, the problems related to forms analysis and the mailing plan will naturally vary with the size of the form, the number of pages in a form set, and whether other papers are to be mailed with the form.

Often the quantity of forms to be used for a given period will be large enough to be considered a "mass" mailing operation. If so, automatic equipment should be considered as an economy factor. Machines are available that can automatically collate, fold, and insert documents into an envelope at high speed.

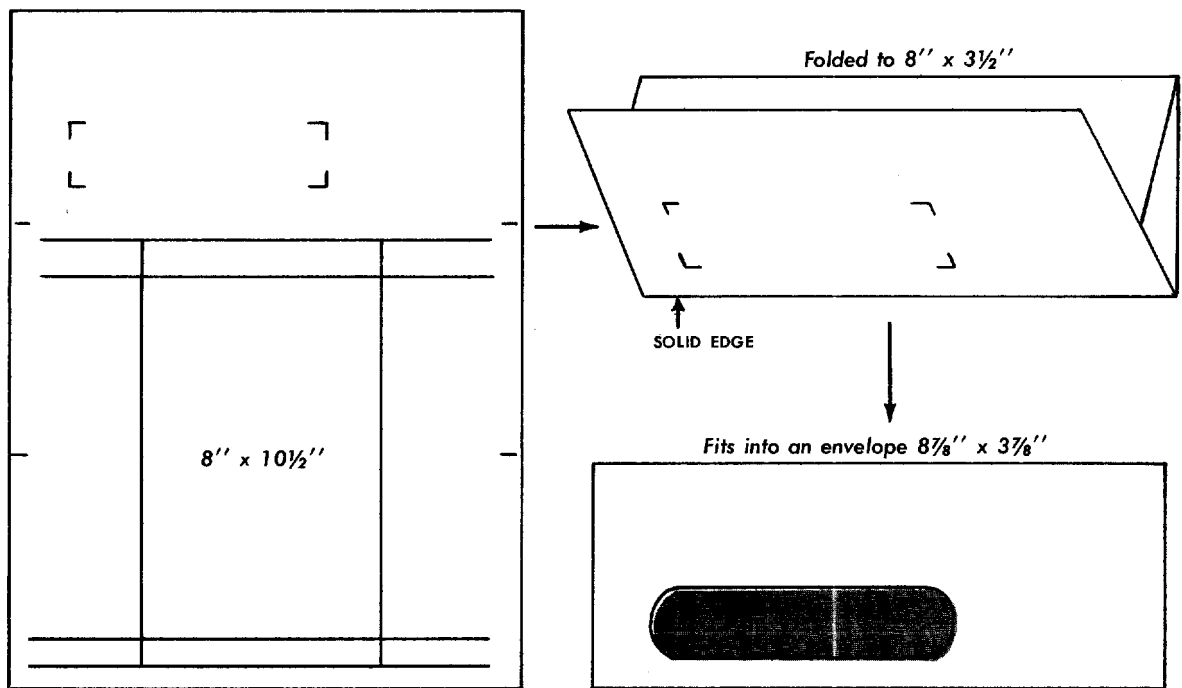

Figure 35

Other machines, and less expensive, are available which only fold documents. If the collating and folding job can be accomplished at the time of printing, of course, that should normally be included in the specifications.

When feasible, the form should be folded to the exact mailing size. For example, an 8'' x 10 1/2'' form can be folded to 8'' x 3 1/2'' when printed, if it is to be mailed in an envelope 8 7/8'' x 3 7/8''. Such a folding operation should be "wrap around fold face out" so the solid edge is inserted first into the envelope. See figure 35.

Circumstances which justify the use of special equipment vary with agencies and with kinds of forms. An analysis of equipment costs compared with time and labor saved will point the way. In some instances when it is important to save time, even an increased cost in the use of special equipment may be justified. In making the calculations, two factors must be taken into account: (a) the initial and maintenance cost of the equipment and (b) the volume of work to be handled. As a rule of thumb, equipment of this kind that will be in operation some 20 hours a week is almost always justified.

Accompanying Papers

There are many instances when a letter or some kind of instruction accompanies the form. Sometimes additional forms or stuffers are mailed together. There are even justified occasions when return envelopes are included. Once these details are known, the best method of mailing can then be planned.

One form, for example, may have a perforated portion of the form to be returned. Another, a separate sheet. In the latter case, the collating job on the printing presses is much faster and cheaper than subsequent collating by hand. When practical, the form and accompanying papers should be printed as a unit and folded or assembled for mailing at the time they are printed. Is the return portion or separate sheet for the benefit of the Government or the individual? If for the Government, and a return address envelope will assure its return, perhaps one should be included in the mailing. Return address envelopes, however, are prohibited under certain conditions. Their proposed use should be cleared with the agency mailroom or a postmaster.

Forms Addressed for Mailing

The mailing plan is different when addressing is done by a typewriter, by an addressing machine, or by hand. It is different if the addressing is to be done on the envelope or on a mailing slip or label. It is again different if the mailing slip is a gummed label or one that will require the application of mucilage. It is still different if the kind of addressing equipment to be used requires addressing on the right or left side of the form.

Closely allied to the question of addressing is the mailing list used for this purpose. Lists, of course, should be kept up to date. This may be done by including a phrase in the address box of the preaddressed form that reads: "Please correct if name or address has changed." Any addresses, and especially mailing lists, should include zone numbers for all cities which use the zone system. Postmasters will add zone numbers to mailing lists on request and at no expense to the agency.

Office Symbols

The use of office symbols for routing purposes are equally valuable in the mail plan. A form completed and returned by the public or by another agency addressed to General Services Administration requires several sorts and handlings before delivery to an action desk. A preprinted address such as,

General Services Administration (NR)
Washington 25, D. C.

pinpoints a specific office; delivery can be achieved immediately, even without opening the envelope.

Window Envelopes

Every effort should be made to use window envelopes, for a dividend of 2 cents each can be realized. See figure 36.

Here again the addressing equipment should be taken into account so that the location of the address and window will match. Although the common placement of the address area is on the

Window Envelope Benefits		Cents
Typing time saved (20 seconds or 3 envelopes per minute).....		.01
Inserting envelope in typewriter, typing, and removing from typewriter.		
Envelopes saved:		
Reduction of envelope requirements by eliminating 10 percent waste because of errors.....		.0075
Reviewing time saved-(5 seconds).....		.0025
Verifying envelope address against letter address.		
Total.....		.02

Figure 36

left side, some equipment is constructed to place the address on the right.

The window area on the form must register with the addressing equipment as well as with the window envelope in which it is mailed. If the same address appears two places on the form, and addressing is done mechanically, the exact amount of "skip space" to fit the machine must be allowed.

The size and location of the address area on window envelopes are set forth in the U. S. Postal Manual.

Self-Mailers

This technique always saves the cost of envelopes and handling them. One agency saved 16 million envelopes a year by converting *one form* into a self-mailer. If the cost of inserting and sealing is added, a sizable saving can be computed.

The self-mailer can be a post card, a single sheet, or a number of sheets. These can be planned as a continuous form, a unit set, or a package (booklet). Some of the types are illustrated in figure 37.

A clear rectangular space, not less than 5 x 3 inches, should be provided on the "self-mailer" for return address, penalty or postage indicia, name and address of addressee, postal endorse-

SOME TYPES OF SELF-MAILERS

- Save typing time
- Save reviewing time
- Save envelopes
- Save inserting time

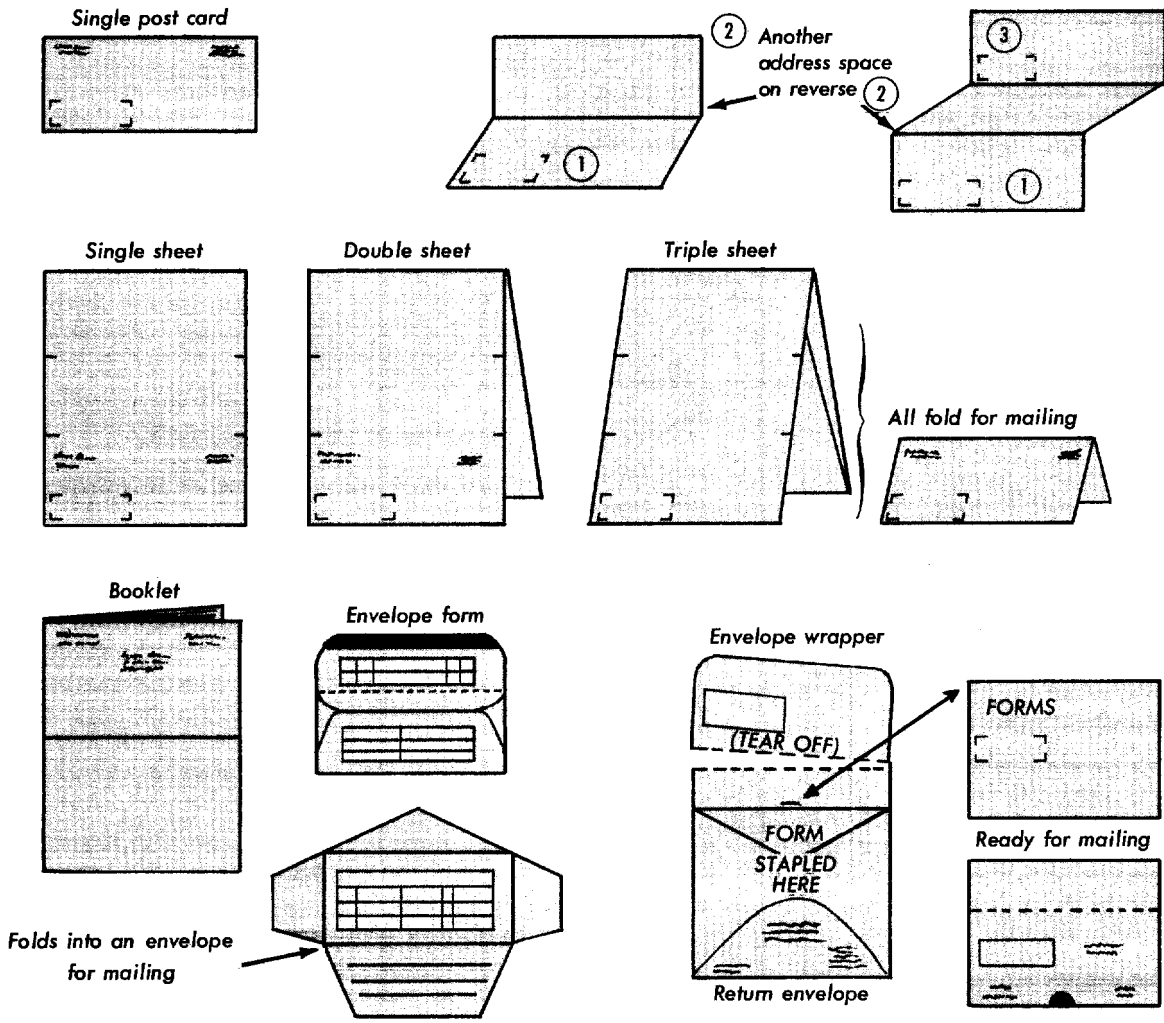

Figure 37

ments, and other pertinent matter. If practical, pieces should be folded to letter size to aid distribution by postal employees.

A self-mailing case study is depicted in figure 38. It illustrates how the Internal Revenue Service eliminated the inserting of 2,980,000 pieces of paper into envelopes and saved the cost of 2,980,000 envelopes. In the process some six forms were combined into one and the address area was placed at the bottom of the form where it would have self-mailing utility.

Time Factor

Time allowances should be made in the mail plan for designing and printing the form, addressing and mailing, collecting and processing the information, and returning it to the requestor. Predetermined time factors, target dates, and schedules comprise part of the analysis job. Sufficient time should be allowed for each phase of the operation, including sufficient time for filling in and returning by the outside user when this is a factor.

VII. FILING THE FORM

Whether a form can be filed and found quickly and easily depends on several factors which forms analysis must uncover. One, for example, is the most logical placement of filing data in relation to the method of filing and the type of equipment housing the form. Another is the kind and size of paper used for the forms, which are not only governed by the filing equipment and supplies used but also by the length of time the form is to be kept and the usage to which it may be put.

The questions in this area of forms analysis are eleven in number and are contained in figure 39.

FILING THE FORM	
1.	Will the form be filed in standard file cabinets, on shelves, in visible files, or in folders?
2.	Will the form be filed in folders or in trays without folders?
3.	Will the form be filed loose, or, if fastened, at what side of the form and by what manner of fastening?
4.	Will all copies of the form be filed in the same manner?
5.	Will other papers be filed with the form?
6.	How long will the form be kept as a record?
7.	How much handling will the form receive in filing and refiling?
8.	Will data be posted to the form after initial filing?
9.	How frequently is the form referred to after it is filed and how fast is it needed?
10.	Will the form be used with a signal device?
11.	Will the form or copies of it be filed in a pending or followup file?

Figure 39

PLACEMENT OF FILING DATA

The answers to the first five questions in figure 39 will tell the analyst, among other things, where the filing data should be put on the form.

Its placement in the most accessible position will save time, and sometimes save tempers. One example of poor placement was contained in one of the early Government ration forms used in World War II, which had the filing data (in this case the name of the applicant) in the *exact center of the form*. The forms were universally filed vertically in corrugated boxes in the ration board offices all over the country.

In order to find an application, the first step was to guess its probable location. The next was to separate and lift each form completely out of the box, locate and read the name item, and keep doing this, one application at a time, until the right name was discovered. If the name (filing data) had been in the upper-right corner, the likely batch of applications could have been "riffled" and the right name turned up in a fraction of a minute.

Instead, lines of applicants, blocks long, waited their turn. An observer held a watch on the actual time consumed by a clerk in handling an application. The average was 9 minutes to find the application and 5 minutes to process it.

The following illustration (figure 40) shows the most commonly used placement areas for filing purposes. When the form is filed in visible equipment, for example, the lower-left corner is often most suitable. The upper-right corner is usually the best location for forms filed in vertical equipment. The lesson to be learned, in any event, is to determine where the form will be filed before designing it.

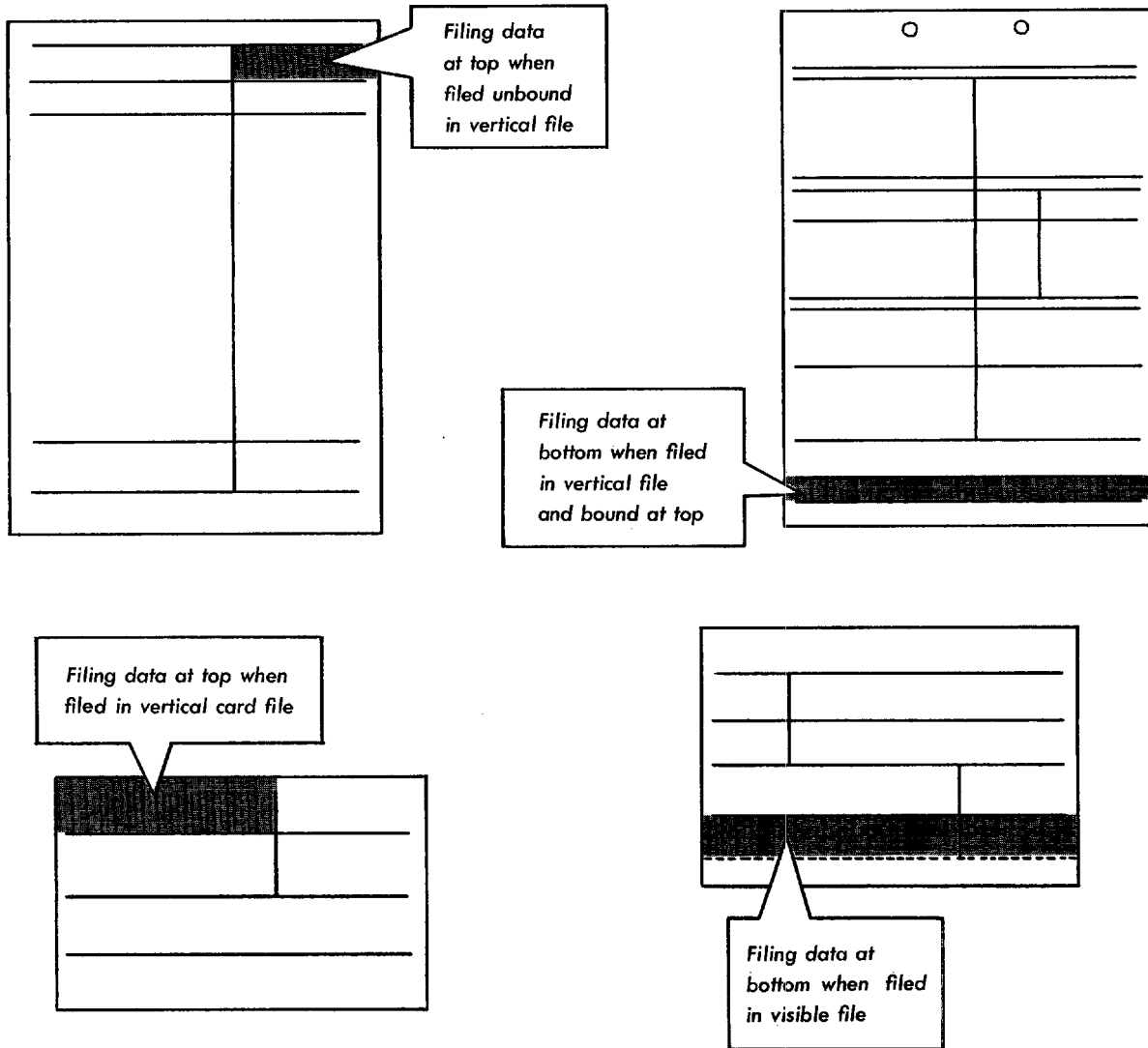

Figure 40

SIZE

The first three questions in figure 39 raise the factor of filing equipment size. The equipment available to hold the form should be considered in determining the size of the form.

Standard Sizes to Fit Standard Equipment

The forms analyst should be extremely wary of nonstandard sizes. This wariness should extend to legal-size forms.

One agency designed a form just $1\frac{1}{2}$ inches wider than a standard legal-size sheet. Millions of copies were printed, and then it was found that the form would not fit standard legal-size cabinets. The agency had special cabinets—3,000 of them—made to fit the forms at a cost of \$75,000 more than standard sized cabinets would have cost. This was a public-use form, so the persons who filled them in had a comparable filing problem with the copies they kept. An analysis of the form was made-

Result? It now folds to a standard letter size and fits standard filing equipment.

How extensively legal-size forms are used depends upon the agency, but there are a few cost factors which should be considered before a legal-size form is adopted. Legal-size cabinets cost 10 percent more than letter-size cabinets when purchased from the General Services Administration Stores Catalog, 11 to 13 percent more when purchased in the open

cost of additional clerical time required in making the filing search. At the other extreme is an oversize form forced into a letter-size file by folding the form a number of times. When this is done, the file folder reacts like an accordion, and file searching is slowed down. Figure 41 illustrates the relationship of forms size to easy filing.

PROPER SIZE CONTRIBUTES TO
UNIFORM AND ORDERLY FILES

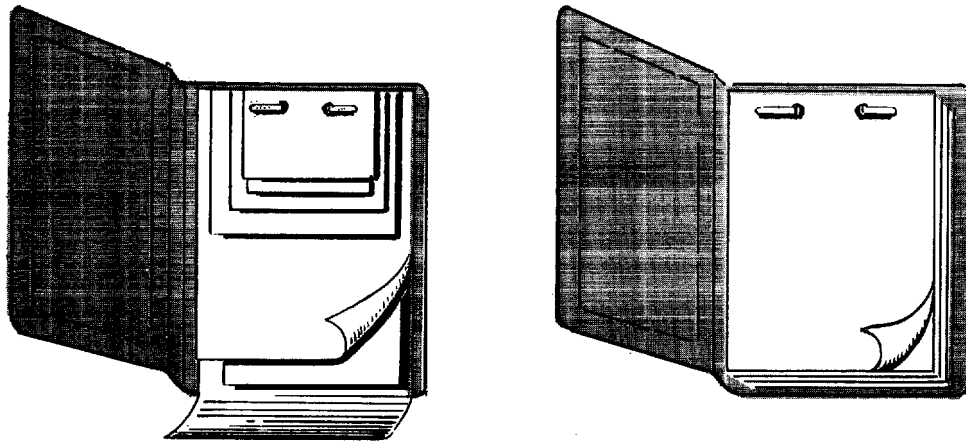

Figure 41

market. They occupy 20 percent more space. There are no known legislative or legal requirements that certain forms or types of forms be on legal-size 8'' x 14'' paper. In view of these considerations, the use of legal-size paper for forms should be weighed carefully.

Relationship of Size to Related Papers

The size of related papers with which a form is filed is a matter that is often overlooked. A form of a proper size can contribute to orderly and uniform files and facilitate handling and searching. On the other hand, an 8'' x 7'' form interfiled with 8'' x 10½'' sheets is easily buried and hard to find. This is even more true with a 4'' x 6'' form. If a file is referred to frequently, any printing savings from a smaller form can be more than offset by the

PAPER

The filing factor inherent in question 6 in figure 39 is not the sole factor to consider when selecting the proper grade of paper, but it should not be overlooked.

The grade of paper selected should be commensurate with the amount of filing and refiling expected for the form. The greater the wear the heavier or tougher the stock should be. A suitable paper stock should also be selected if a signal device is to be clipped on a form. Clipping and unclipping can tear and dog-ear a form unless a durable grade of paper is selected.

POSTING

Some forms are designed primarily as a posted record. In these cases consideration should be

given not only to the other factors already mentioned but also to the manner and frequency of posting and reference. For instance, an 8" x 5" card record designed for a visible pocket-type file should allow for hand posted entries because machine posting (typewriter or other) would require removal of the card each time. This is a slow process. If machine posting is the controlling factor, then perhaps the form should be designed as a vertical record, perhaps for tray-type equipment. Again, if posting to each card is relatively infrequent, a standard vertical card file may serve at a housing cost of approximately one-fifth cent compared with 28 cents per card for pocket-type visible equipment.

FILING OF PENDING CASES

It is often desirable to have some copies of a form held together in a pending status awaiting subsequent action. If this is known in advance, then the analysis can point to the best way of initially assembling and fastening the several pages: folding, pasting, sewing, or stapling. The method of fastening, in turn, can effect

the method of writing (adding subsequent entries).

For instance, a four-part form is prepared and partially filled in; one copy is retained in the preparing office and the three remaining copies are forwarded to another office. The three copies can be held in a pending file awaiting a shipment. Upon receipt of the shipment, the set is pulled from the file, entries are made by hand or typewriter, and then two copies are forwarded for further action. This procedure may point to a form assembly from which one copy can be easily removed and yet not separate the remaining two copies.

LOOSE FILING

Forms should be filed loosely in folders instead of being fastened, unless the folder travels a great deal. If originators will make this decision during the analysis period it may conserve space which would otherwise be left for margins, or in some other way it may make the design of the form easier through giving the designer greater freedom in placement of copy.

VIII. IMPROVING PROCEDURES THROUGH FORMS ANALYSIS

A great many of the suggestions in this handbook have necessarily been in terms of analyzing each form individually, at the time of origination, when revised, or when reprinted. Such analysis momentarily subjects each form, each item, and each copy to scrutiny, as a result of which some fall by the wayside disapproved. This is the way much forms analysis gets done. It is a good way to make paperwork improvements, because it throws the spotlight of analysis on a unit frequently susceptible to improvement.

As pointed out earlier, every form is embedded in a procedure. It frequently is the instrument which puts the procedure in motion. Even so, the form is generally subordinate to the procedure, not the procedure to the form. The procedure is the senior partner; the form is junior, sometimes very junior.

In this connection we should remember the distinction usually made among a method, a procedure, and a system.

- A method is a set of steps used by an individual worker to get a task done.
- A procedure is a group of methods; in its paperwork aspects it consists of all the steps that are taken to record, analyze, transmit, and store information to serve a single, specific purpose.
- A system is a group of procedures to serve a series of closely related purposes.

A system, for example, is required to collect income taxes; a procedure is required to make refunds; a method is needed to check the arithmetical accuracy of each return. A system is needed to procure aircraft; a procedure is required to prepare purchase specifications; a method is required to file those specifications.

Under these definitions, checking all the forms in a system would be an involved and very lengthy assignment. A better bite to chew would be the forms in a procedure. One procedure may have only a few forms embedded in it. At the most, a procedure would not re-

quire over a hundred forms. Because they have a common matrix, all the forms in a procedure tend to dovetail and interlock. They invite analysis because of their affinity to a common purpose.

Forms analysis at the procedural level, therefore, is an ideal way to look at forms that possess kinship. Since so many forms are kin, and since studying them individually, apart from that kinship, denies one the whole picture, it follows that to get the larger picture and make the analysis more thorough and complete, each procedure and its related forms should be examined periodically.

REASONING BEHIND THE FACTS

To study a procedure, and the role forms play in it, the analyst first needs facts. He needs to know the answers to the what—when—where—who—how questions shown in figure 42 for each step of a procedure involving a form, always followed by the inevitable—why?

In addition to the facts the analyst thus learns the reasoning behind them. In this way, too, he discovers any source documents upon which fill-in of the form depends. Also he learns what copies are distributed after the record is written.

REVIEWING THE BACKGROUND DATA

The better informed the analyst is about any procedure and its related forms the easier it will be to convince others of the need for forms analysis. Also, the more successful will be any discussions with the people working with the forms. By familiarizing himself with background data before discussing the role of all forms in a procedure with the people who prepare and use them, the analyst will be able to:

- Ask better questions and better interpret the explanations.

GUIDE FOR BASIC ANALYSIS

ASK—TO GET THE FACTS	ASK—WHY?	ASK—TO MAKE THE IMPROVEMENTS
<p>NEED</p> <p>What do the forms in the procedure accomplish which justify their existence?</p> <p>What other forms are related, or duplicate in whole or in part the information requested?</p> <p>What inadequacies are there in the forms in the procedure?</p>	 <p>WHY this need?</p>	<p>NEED</p> <p>Is the information needed?</p> <p>Does the cost exceed the worth?</p> <p>Is there a better source or a better way?</p> <p>Can the forms or items on the forms be—</p> <ul style="list-style-type: none"> Combined? Eliminated? Simplified or resequenced? Added?
<p>PEOPLE</p> <p>Who requires the data?</p> <p>Who enters the information?</p> <p>Who extracts the information?</p>	 <p>WHY by these people?</p>	<p>PEOPLE</p> <p>Can the work be assigned to other units or clerks to simplify the work or combine its handling?</p> <p>Can the forms in the procedure be resequenced to simplify the entering or extracting of the information?</p>
<p>PLACE</p> <p>Where are the forms in the procedure written and processed?</p> <p>Where are the forms sent?</p> <p>Where are the forms filed?</p>	 <p>WHY here?</p>	<p>PLACE</p> <p>Can the writing of the forms and their processing be combined with similar work done in another unit?</p> <p>Can the forms be completed in the field without the need of feeder forms, or having to copy the information on another form in the office?</p> <p>Does the design of the forms aid in their filing, finding, storage and disposition?</p>
<p>TIME</p> <p>When are the forms in the procedure written?</p> <p>When are these forms processed?</p> <p>When are the forms filed?</p>	 <p>WHY at this time?</p>	<p>TIME</p> <p>Are the various processing steps taken in their proper order?</p> <p>Can the peakloads be leveled off by better scheduling of the forms flow?</p> <p>Can information be requested so it can be processed during a slack period?</p>
<p>METHOD</p> <p>How are the forms in the procedure written?</p> <p>How is the information on these forms processed?</p> <p>How are these forms transmitted?</p> <p>How are forms filed?</p>	 <p>WHY this method?</p>	<p>METHOD</p> <p>Can the writing method be changed for the better?</p> <p>Can the routing or mailing method be changed?</p> <p>Have the forms been geared to the most efficient office equipment?</p>

Figure 42

- Obtain better cooperation because he will demonstrate interest in the work and willingness to help.
- Shorten the time of the interviews because the basic facts are known.
- Obtain all the information needed in one visit without interrupting people several times.

Usually several sources are available for obtaining background data important to a procedural study, featuring the forms involved. These are the sources it pays to check:

- Manuals, regulations, or directives describing functional responsibilities and procedures bearing on the forms under study.
- Organization charts showing relationships of the unit responsible for the forms with other units.
- Reports of previous studies and correspondence concerning problems encountered in preparing or using the forms.
- Functional and historical forms management files. From these the analyst can review the history of the development of the form, identify any forms which are similar or related to the ones under study, and determine how often and in what quantities additional copies of the form were reproduced.
- Completed forms in file showing types of errors, revisions, or additions made in completing the forms.
- People who participated in previous studies of the forms.

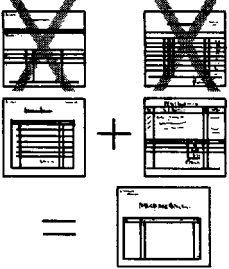
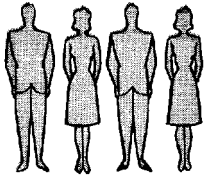
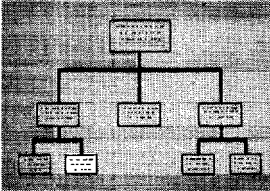
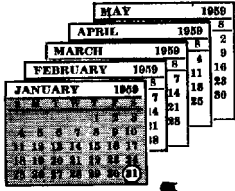
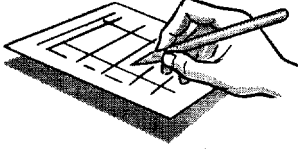
An analyst may find that even an operating official, working on his own forms, has incomplete background facts about the procedures controlling the use of those forms elsewhere in the organization. Others with whom the analyst is working may likewise be unfamiliar with various parts of the paperwork background. He may need to prepare an outline to follow before starting interviews with the people concerned with the procedure and its forms.

DISCUSSING AND OBSERVING

Interviewing people in any procedural study should never be done without adequate preparation. Most analysts have found it desirable to:

- Clear with the supervisor of the person to be interviewed and have the supervisor make the initial contact. Explain the purpose of the study to the supervisor.
- Make an appointment for a discussion. Consider the workload of the person and select a time that makes for least interference. Plan for short interviews—no longer than 1 hour.
- Plan the sequence of the main questions for the most logical development of the study.

Generally there are at least two groups of people to be interviewed—those concerned with entering data on forms and those concerned with extracting or summarizing data from them. In addition there may be people who are concerned with other phases of handling or processing the forms involved, such as those who review, audit, transmit, or file them. When more than one copy of any form is prepared, different groups of people may be concerned with the data extraction and processing performed for each copy.

From each person interviewed the analyst first determines how much of the requirements for each form he is responsible for. Does an entire form exist solely or partly for his use? Which items are entered on that form and which copies are prepared to satisfy his requirements? For what purposes does he need forms, items, or copies?

The analyst discusses each processing step and the method of processing followed by each person while working with each form. He makes a note of the supplies and equipment used. He also notes how often a person processes the form and the average amount of time he spends on one processing. He examines any forms from which or to which information

is copied as a part of preparing or using the form under study. He collects filled in copies of all forms and copies of any related documents pertinent to the study.

The analyst does not allow the interview to be rushed or hurried. He takes plenty of time to make sure an understanding is reached on all work being done. He tries to make sure he has obtained all links of information found missing during his review of background data. He writes down any reminders needed to reconstruct the forms processing procedure after the discussion is over.

The analyst does not rely entirely upon what is said. He goes to the point of use and *watches the complete process.*

CHARTING THE FACTS

There are several ways to chart the progress of a form through a procedure and the course of each copy of a form from origination to final disposition. For this purpose Forms Distribution Charts are covered in chapter IX, "Tools for the Analyst." They are not intended to take the place of analysis or substitute for the preparation of work process charts. They can give clues to the existence of extra copies, the backtracking of copies, and are a starting point for study and effective improvement work. They can be prepared rapidly.

The facts do not *need* to be charted, unless they are complex and a graphic presentation is desirable to make them easily understood.

In charting the contents of forms, the simplest way to compare items is to make a spread sheet containing a brief description of each item and the form involved. A Recurring Data Chart, described in chapter IX, is frequently helpful in this connection. Either the spread sheet or the chart will give the analyst a clear picture of:

- Those items common to all forms in the group
- Those items common to some, but not to all the forms
- Those items found only on one form in the group

Reductions in the number of forms are usually based on data of this kind.

DEVELOPING AND PRESENTING IMPROVEMENTS

After obtaining and organizing the survey facts, and possibly charting some of them, the analyst has come to the time for thinking about them. No handbook can tell an analyst how to think. He either knows how or he doesn't.

Once final analysis begins, it is a bad time for weak or blind spots to be revealed. For this reason most analysts hold off their cerebral work until they feel sure they know every aspect of the form or forms under study. Verifications of findings are given one last check, because an overlooked fact can "throw a curve" when an improvement is presented.

The kind of challenges made in chapter III are valid for use again at this point. The analyst determines for all forms used in the procedure under study:

- If all items are needed
- If new ones should be added
- If information is available at another source
- Whether forms can be eliminated, combined, resequenced, or simplified
- If all copies are needed
- If the cost exceeds the worth.

In this way the analyst knows how far he can go in questioning the essentiality of the procedure. He is now ready to develop any proposed form or forms and to recommend changes in the related procedures or equipment. He uses the best part of what exists—changing only those portions which provide real advantages. There is no point in change for the sake of change. Unless a real advantage is revealed, no change should be made.

The analyst screens his findings, his proposed form or forms, and the necessary procedural changes and equipment recommendations with a qualified individual—one of the agency's systems and procedural analysts, the agency records management officer, or one of the agency's printing and equipment specialists.

If a visual presentation will help, the analyst makes the necessary charts showing the "after" work flow. He makes a pencil layout of the form or forms. These, included with his "before" charts, developed in the fact-finding stage, are all the pictorial presentations his improvements will need to afford easy grasp by the viewers.

It is advisable to present any detailed cost, potential improvements, and man-hour savings in written form.

It always pays to take one final look at any proposals before letting them go forward. At this time the analyst asks for the last time:

1. Does the proposal *improve operations*?
2. Does it combine, eliminate, or simplify any or all the forms under study?
3. Will there be a reduction in man-hours required?
4. Will there be a reduction in the number of error hazards in preparing each form?
5. Will there be a reduction in the cost of the forms?
6. Will the proposal improve employee morale?
7. Will the proposal improve public goodwill?

The analyst rests his case.

IX. TOOLS FOR THE ANALYST

Various files and charts are the keys to effective forms analysis by a forms management office. Of these the most important is the functional file, whose development and use is basic.

DEVELOPING THE FUNCTIONAL FILE

Samples of all forms must be collected to make up the file. It should include all forms used, numbered and unnumbered, whether originating in the agency or elsewhere, whether temporary or permanent, and regardless of the method of reproduction.

The main purpose of this file is to provide:

1. A functional and subject reference to approved forms.
2. A basis for effective analysis to eliminate unnecessary forms and prevent the creation of new forms which duplicate the functions of previously approved forms.
3. A means for the review of like or similar forms pertaining to the same function or subject.

Organizational charts, functional statements, manuals, subject indexes of files, and any other literature which describes the purpose and functions of the organization also should be collected. These must be studied thoroughly—not skimmed over superficially.

Based on the study of the forms and the literature, a tentative list of subjects into which the forms in the program will fall should be developed with a brief explanation of each subject. A list of the actions performed by each form should then be made.

Typical lists are shown in the following illustration.

SUBJECTS

1. **BUDGET AND APPROPRIATIONS**—All forms relating to annual, deficiency, and supplemental estimates and appropriations; apportionments, allocations, allotments, and transfers of funds; budget material; preliminary estimates; and internal fiscal investigations.
2. **COMMODITIES**—All forms, except excise tax forms, relating to agricultural products, dairy products, manufactured products, distilled spirits, tobacco products, firearms, narcotics, natural resources, mining and drilling operations and their products and by-products.

ACTIONS PERFORMED

- | | | |
|----------------|--------------|--------------|
| 1. Acknowledge | 7. Assign | 13. Collect |
| 2. Account | 8. Authorize | 14. Control |
| 3. Agree | 9. Cancel | 15. Complete |
| 4. Allocate | 10. Certify | 16. Credit |
| 5. Analyze | 11. Claim | 17. Decrease |
| 6. Apply | 12. Classify | 18. Debit |

Figure 43

Each form must be examined in order to determine its proper classification. The analyst does not rely on the title alone. But, “keywords” relating to the purpose of the form aid materially. See chapter IV. He looks at each item on the form, and if necessary finds out from the originating unit how it is used. Most forms will be easy to classify, but some will be questionable. These can be placed in a miscellaneous folder during the initial sort. Then, as classifying progresses, they will gradually fall into place.

After all forms are properly classified and filed in the folders by subject, the analyst studies the forms in each subject folder to determine the action performed by each form. He files all the forms having the same subject and action performed into a folder labeled with the appropriate subject-action classification. Figure 44 illustrates this.

Where two or more functional classifications are equally appropriate for one form, the analyst cross-references them. He uses a copy of the form showing the cross-references, or he uses a cross-reference sheet showing the number and name of the form, and cross-references. The form should be filed under one classification number, and cross-references to the form should be filed under each of the other classifications. It is advisable to keep these cross-references to a minimum.

All forms bearing the same functional classification number should be filed in the same folder, regardless of the origin of the form or the method of reproduction.

USING THE FUNCTIONAL FILE

Forms management offices never clear a new or revised form without using the functional file to see that the form does not duplicate a similar form, or whether other forms can be eliminated by it or combined with it.

Review of a request for a new form.
Upon receiving a request for a new form the forms management office should:

- Determine the function of the proposed form.
- Refer to the list of subject and action classifications and determine the proper classification for the form.
- Check all the forms filed in the folder under the particular classification to see if any of them serve the same or a similar function.
- Study the proposed new form and existing forms to determine whether an existing form can be (1) substituted for the proposed form, (2) consolidated with it, or (3) eliminated.

With accurate classification and careful maintenance of the functional file, no difficulty should be experienced in locating forms under the proper subject heading. Inasmuch as some subjects are closely related, it is possible to classify a form under several headings. It is therefore advisable to check the forms under related subject and action headings.

Review of a request for a revised form.
When a revised form is requested, its classification should be checked, as the changes that have been made on the form may change its classification.

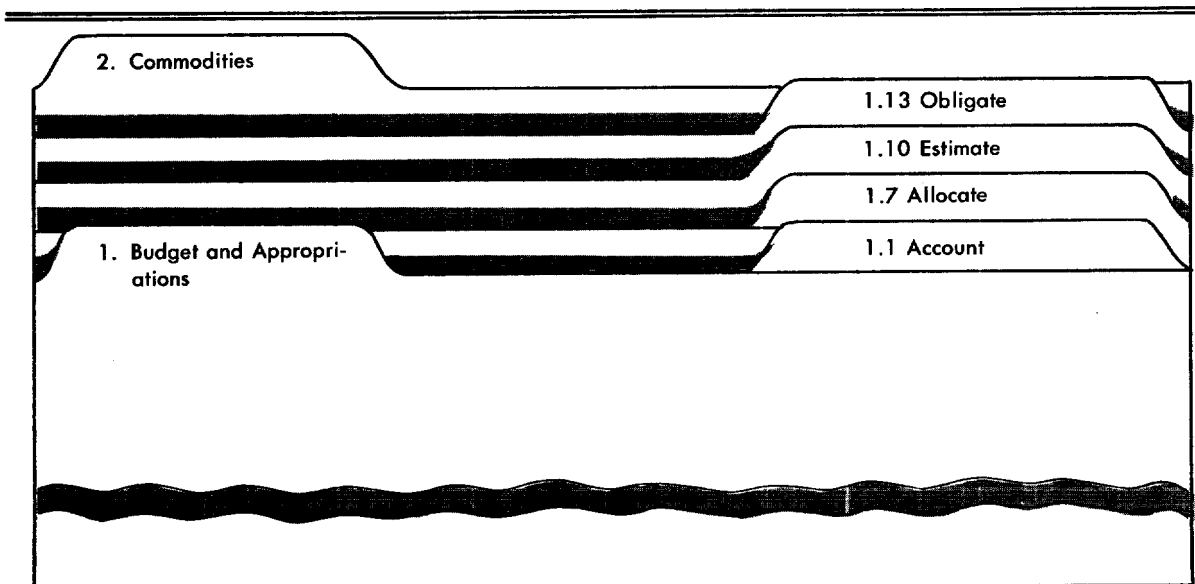

Figure 44

EXAMPLE OF ENTERING INFORMATION ON RECURRING DATA ANALYSIS CHART

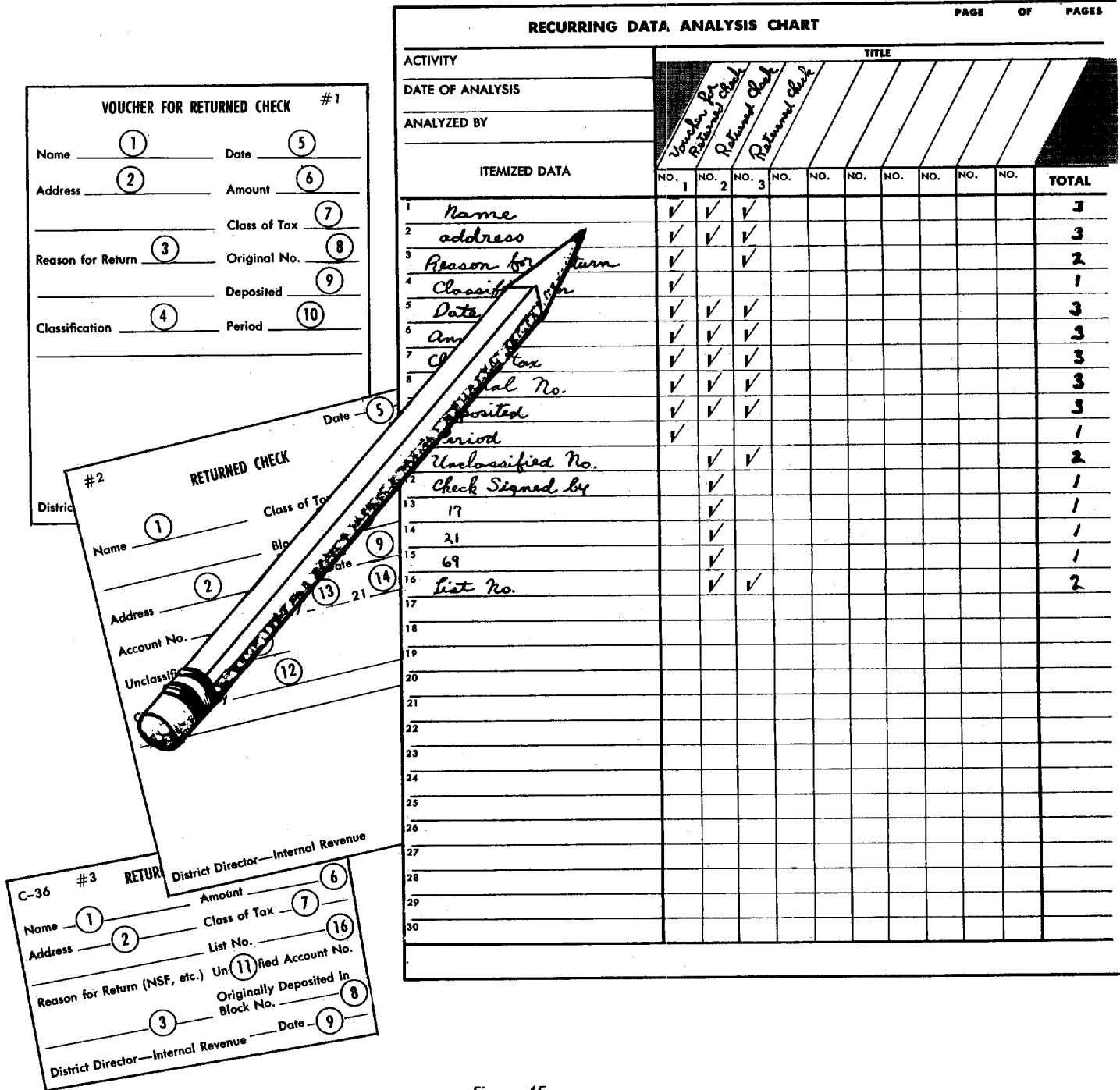

Figure 45

Studies of groups of forms for the purpose of consolidation and elimination. Continuous study of forms in the functional file should be made with a view toward eliminating unnecessary ones and consolidating those which serve similar functions.

Periodic review of the file. A review of the functional file from time to time can reveal forms which should be studied. Forms which have not been revised for several years are especially suspect, for example.

RECURRING DATA CHART

This chart, illustrated by figure 45, is a tool for simplifying, consolidating, and eliminating forms. By the same token it can be used for simplifying and standardizing procedures in which several forms are used.

How to set up and use the chart. Most analysts have found it desirable to:

- First examine the functional file to determine that all forms of the type to be studied are included. The annual usage of each form is ascertained and the forms are arranged in sequence starting with the form having the greatest usage. In the same sequence the form number and title of each form are entered in columns across the top of the page.
- Start with the first form listed, numbering each item shown on the form, starting with No. 1. These identifying numbers and items are entered in the stub column of the chart and a check is placed in the form number column opposite each item in the stub column.
- On the second form listed, number each item that corresponds with those items listed in the stub column of the chart, using the same identifying numbers. Corresponding items are then checked in the second form number column, opposite the identifying number.
- Additional items appearing on the second form are given identifying numbers on the form, starting with the next consecutive number shown on the stub column of the chart. These additional identifying numbers are entered in the stub column and

are then checked in the second form number column.

- Repeat the same action for each form being analyzed.

Results of analysis. The check marks across the page will show those forms offering the best possibility for consolidation, because the check marks show the extent of duplication in content. Consolidation depends upon extent and kind of duplication. With the completed chart as a guide, determination must be made as to (1) whether those items which recur least frequently are essential or may be omitted, and (2) whether one form, or more than one form, will be the result of the analysis.

Not until the analysis has been discussed with the originators of the several forms should a new, consolidated form be designed and submitted to the originators for approval.

TYPEWRITING MOTION ANALYSIS

One of the purposes of forms analysis is to reduce the amount of writing time required to fill in a form. A scientific means of evaluating that portion of the writing time taken up by typing, particularly where many forms are written at one place, is to apply typewriting motion analysis. This technique enables the analyst to say with confidence that the re-designed form will:

- Increase typing production "X" %
- Save "X" of typing time

To illustrate, if a form that took 8 minutes to fill in is redesigned to be written within 4 minutes, and it is filled in 400,000 times yearly with, potential savings of 1,600,000 minutes (20,500 man-hours), it is worth knowing.

To make a typewriting motion analysis a comparison must be made between the "before" and "after" design of the form. The basic motion factors considered are:

- Keystroke
- Shift to Caps
- Horizontal Space
- Tabular Stop

- Carriage Return
- Vertical Space
- Hand Positioning

This technique is used not as a means of predicting operator performance but only for purposes of comparing "before" and "after" typing time. It does not include items such as:

- Time required to remove the forms from the typewriter
- Time required to position the next set for typing
- Job delays
- Personnel delays
- Delays caused by unusual fluctuations in the volume of work

The Navy Department has a form for typewriting analysis, "Typewriting Motion Analysis Work Sheet," shown on page 55. The detailed instructions on the reverse of this form give the steps necessary to complete the analysis.

PROCESS CHARTS

Process charts can be used to follow forms in their procedural movements and to analyze the interrelationships of forms, procedures, and organizational structures. Many types of charts are commonly used. The principal types, including form-distribution charts, are illustrated on the following pages along with selection criteria.

Such charts are commonly used by management staffs primarily engaged in procedural analysis, work measurement, and work simplification activities. They likewise can be used to good advantage by the forms analyst to simplify procedures through forms analysis, or by operating officials who are interested in promoting efficiency and economy in the internal operations of their offices.

Before attempting to decide upon which chart to use, the analyst should clearly define his purpose. The following questions cover most of the considerations involved:

- Is the chart intended for the analyst's use only?
- Is the chart intended to sell improvements to management?
- Is the chart to be used by supervisors and operating personnel concerned?
- What is the minimum detail required?
- Is an understanding of the correlation between work of various people or groups necessary or desirable?
- How complex is the procedure and how many different flows would require charting?
- Is the problem primarily one of forms distribution?
- How much time can be devoted to developing the chart?

Figures 47 through 51 depict those charts commonly used in forms analysis. For additional information see The Bureau of the Budget Management Bulletin, *Process Charting*.

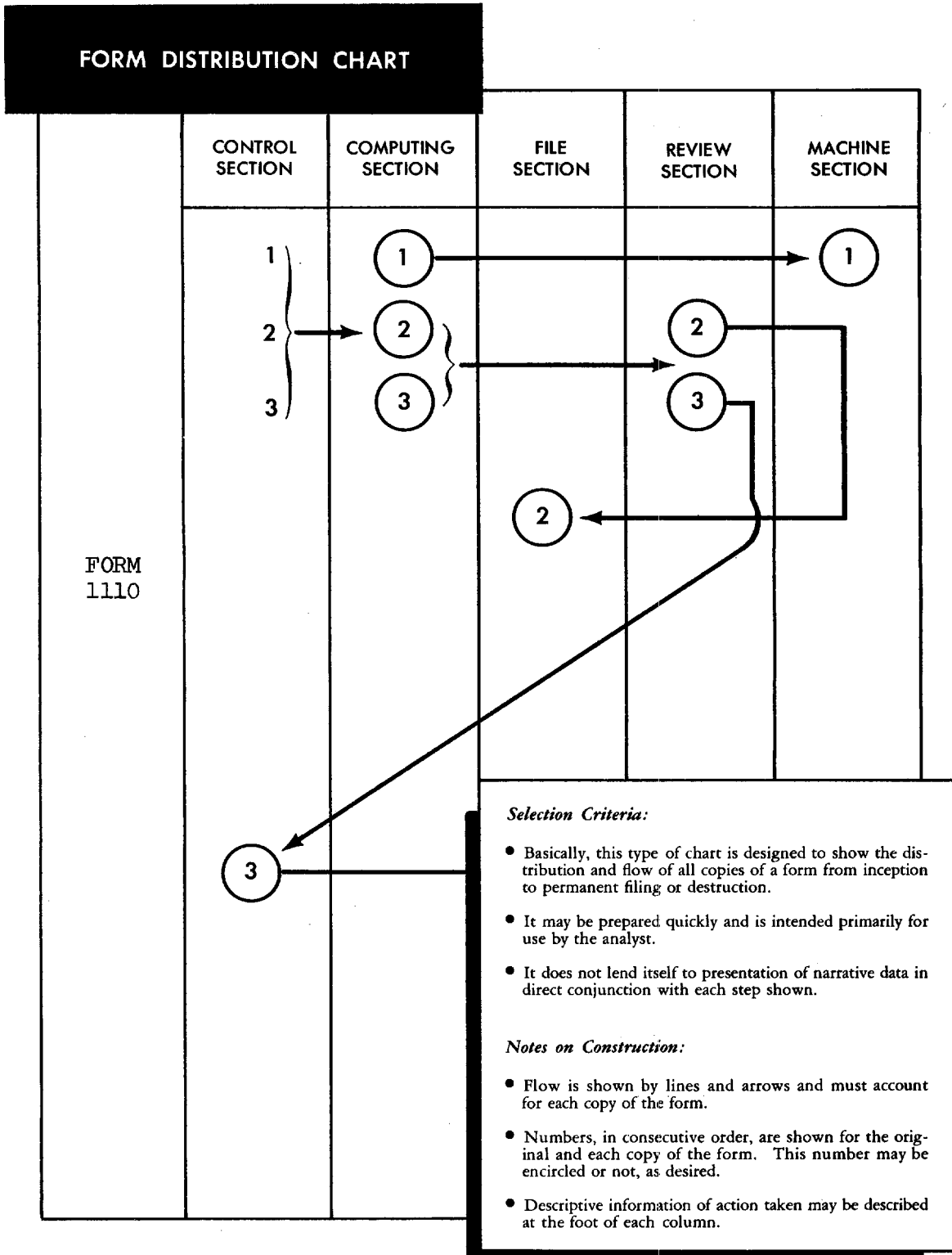

Figure 47

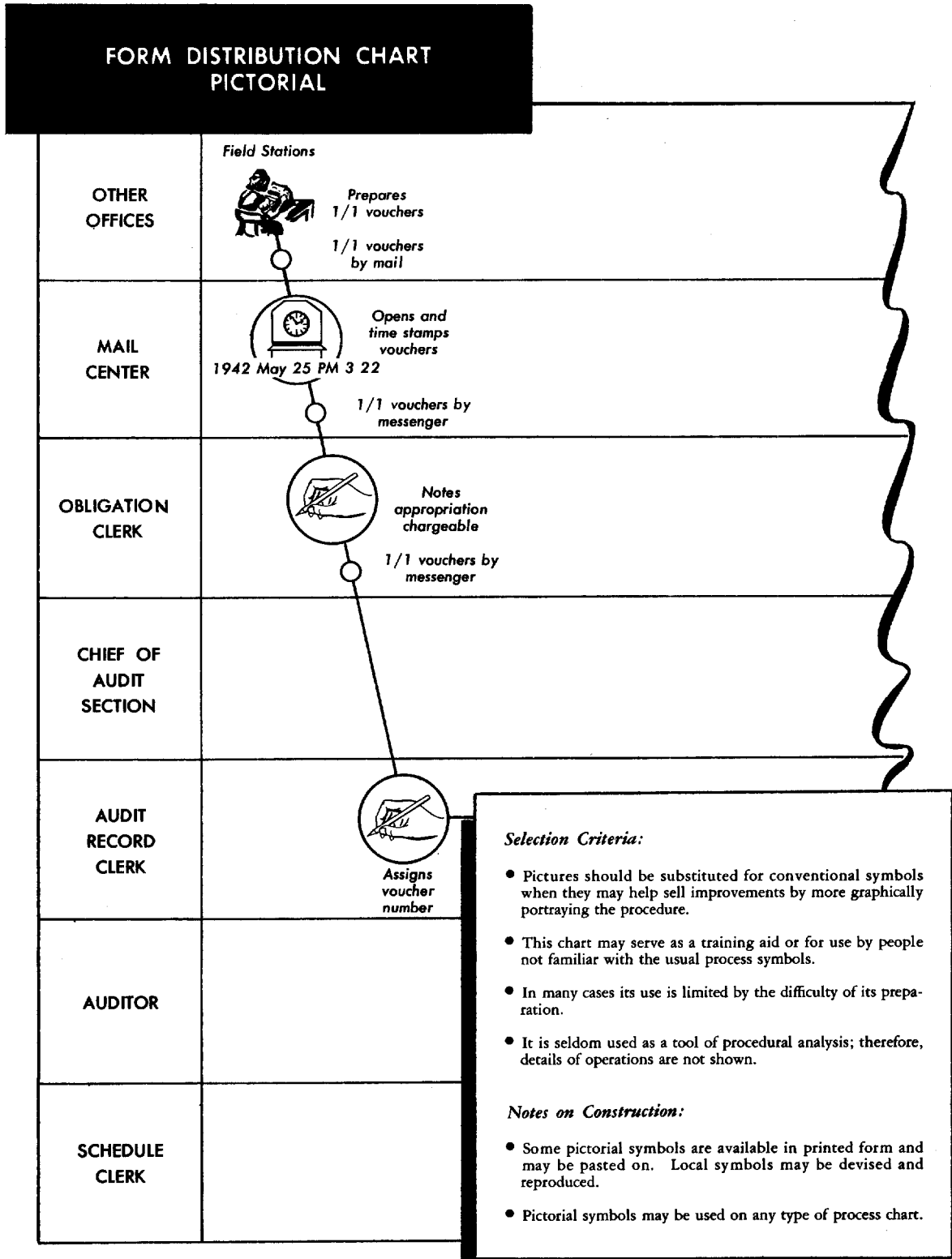

Figure 48

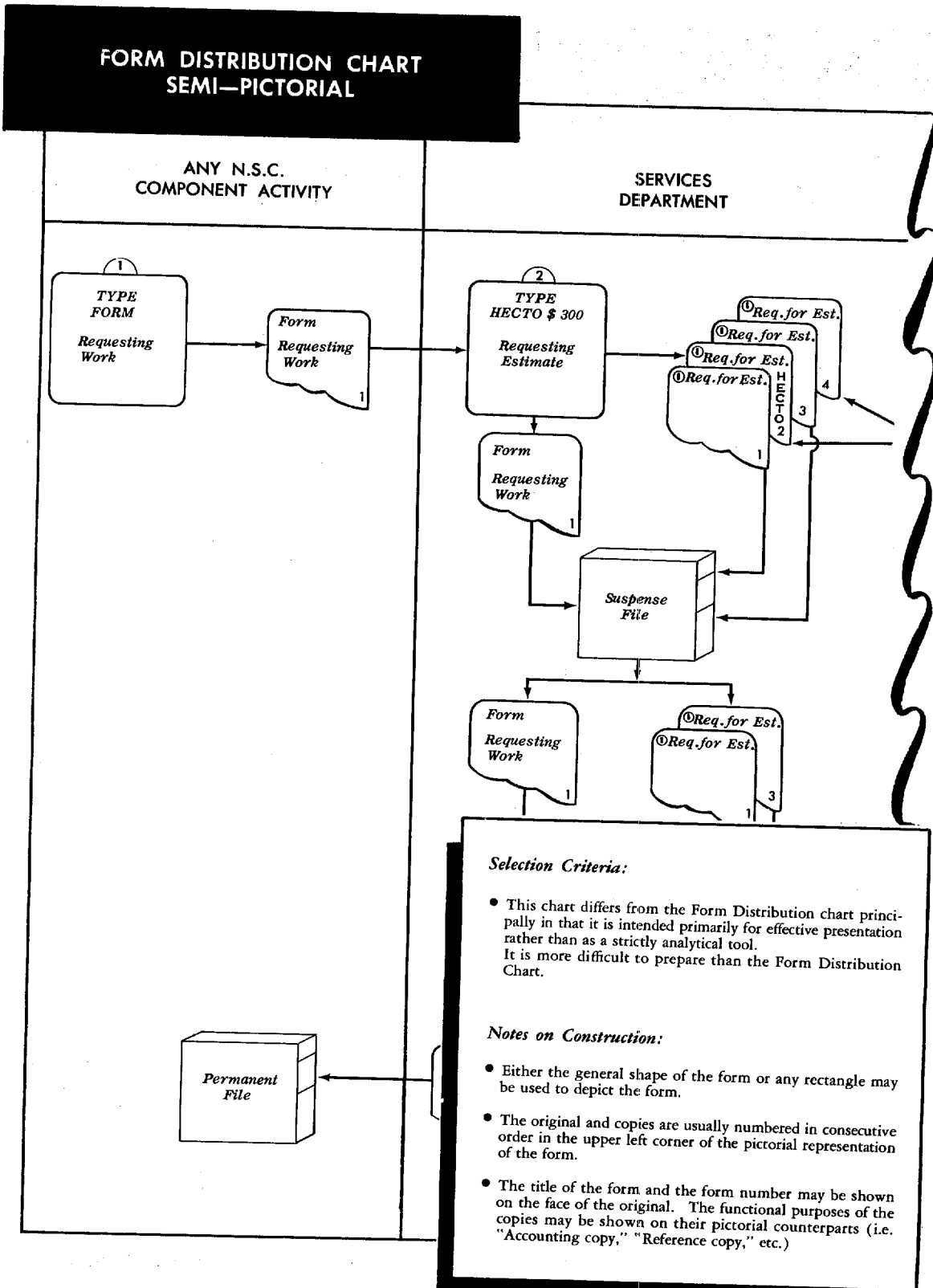

Figure 49

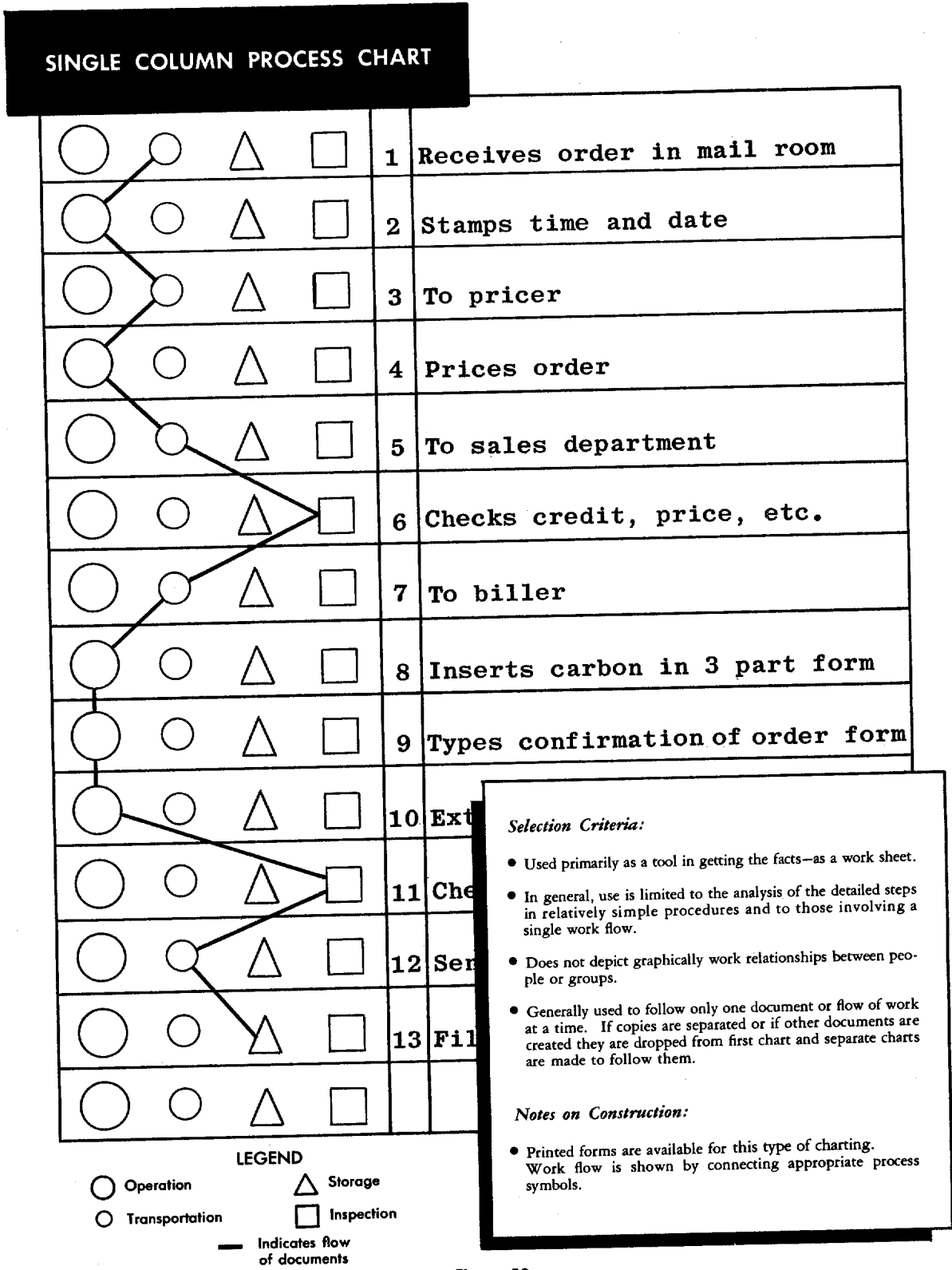

Figure 50

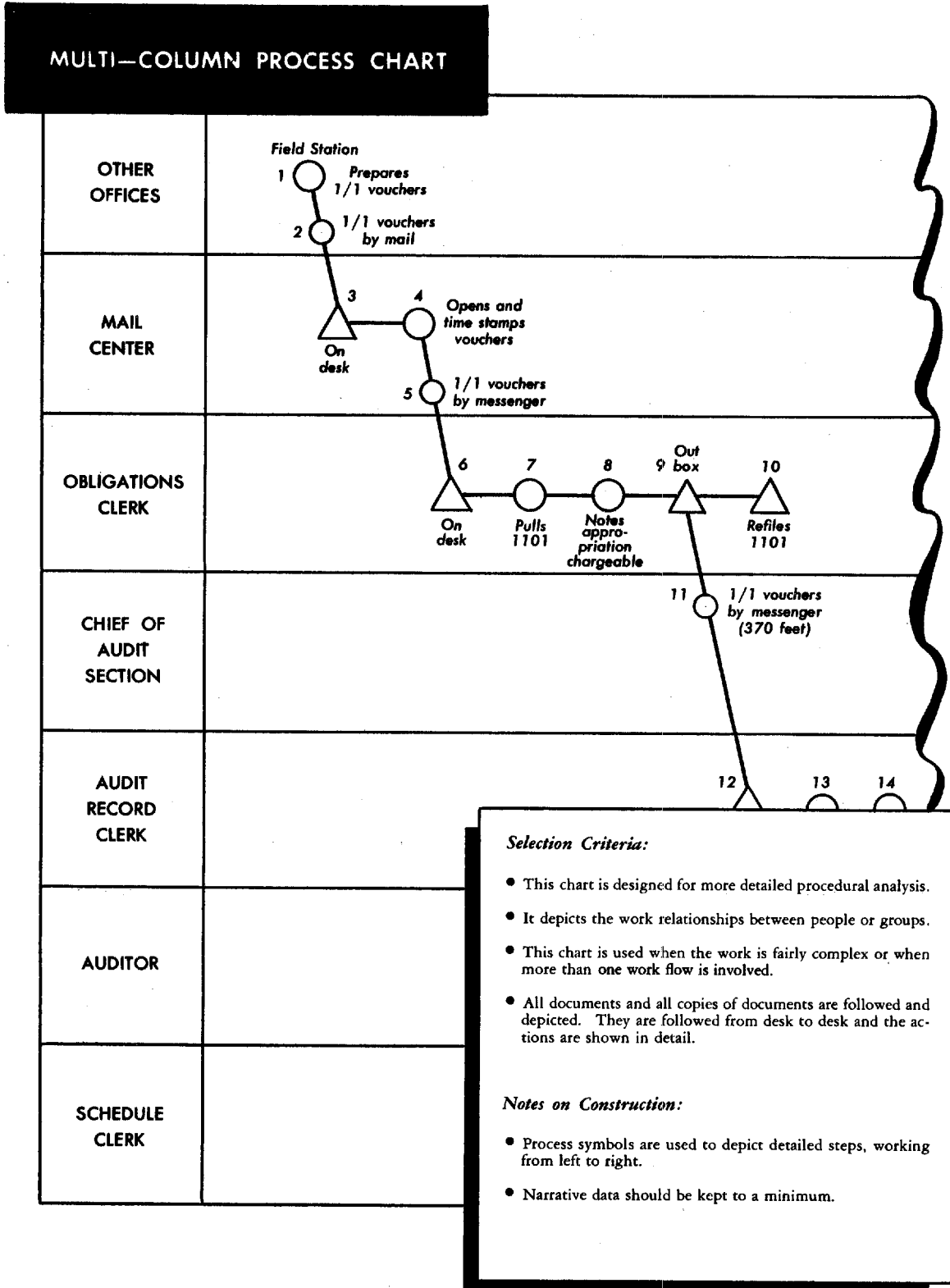

Figure 51

CHECK LIST

The questions are so worded that check marks in the "NO" column indicate the need for corrective action.

- | | Yes | No |
|---|--------------------------|--------------------------|
| 1. Is the need for every form challenged before it is printed?..... | <input type="checkbox"/> | <input type="checkbox"/> |
| 2. Every item?..... | <input type="checkbox"/> | <input type="checkbox"/> |
| 3. Every copy?..... | <input type="checkbox"/> | <input type="checkbox"/> |
| 4. Are like forms consolidated?..... | <input type="checkbox"/> | <input type="checkbox"/> |
| 5. Is the sequence of items easy to follow?..... | <input type="checkbox"/> | <input type="checkbox"/> |
| 6. Does the order of items correspond to that on the records from which information is drawn or to which it is transferred?..... | <input type="checkbox"/> | <input type="checkbox"/> |
| 7. Does the order of items correspond with the clerical routine?..... | <input type="checkbox"/> | <input type="checkbox"/> |
| 8. Is the amount of writing (fill-in) reduced to a minimum?..... | <input type="checkbox"/> | <input type="checkbox"/> |
| 9. Does the form take advantage of writing-machine characteristics?..... | <input type="checkbox"/> | <input type="checkbox"/> |
| 10. Are the filing data and margins on the form consistent with the filing equipment or binders to be used?..... | <input type="checkbox"/> | <input type="checkbox"/> |
| 11. Will titles, numbers, or colors facilitate routing, dispatching, handling, and checking?..... | <input type="checkbox"/> | <input type="checkbox"/> |
| 12. Are all the captions on the form easily understood?..... | <input type="checkbox"/> | <input type="checkbox"/> |
| 13. Will all words on the form be legible under all conditions of use?..... | <input type="checkbox"/> | <input type="checkbox"/> |
| 14. Have the space requirements for each individual item been verified?..... | <input type="checkbox"/> | <input type="checkbox"/> |
| 15. Is there provision for the overflow or continuation of information if regular spaces prove inadequate?..... | <input type="checkbox"/> | <input type="checkbox"/> |
| 16. Is there periodic analysis of the office procedures in which forms are used?..... | <input type="checkbox"/> | <input type="checkbox"/> |
| 17. Do the originators of forms always provide a roughed-out sketch of any new forms?..... | <input type="checkbox"/> | <input type="checkbox"/> |
| 18. Is maximum use made of standard and optional Government forms?..... | <input type="checkbox"/> | <input type="checkbox"/> |
| 19. Is there a functional file of forms to aid in the review of forms?..... | <input type="checkbox"/> | <input type="checkbox"/> |
| 20. Is maximum use made of specialty forms?..... | <input type="checkbox"/> | <input type="checkbox"/> |
| 21. Have the actual users of the form been consulted for suggested improvements, additional requirements, and possible eliminations?..... | <input type="checkbox"/> | <input type="checkbox"/> |
| 22. Is there a written procedure for the use of the form?..... | <input type="checkbox"/> | <input type="checkbox"/> |
| 23. Has the method of transmitting the form been analyzed?..... | <input type="checkbox"/> | <input type="checkbox"/> |



Washington: 1959