

Page Denied

XERO COPY

XERO COPY

XERO COPY

XERO COPY

POSTMISSION PHYSICAL EXAMINATION

1. NAME

[Redacted Name Box]

MISSION DATA: T/O Date
T/O Time
Landing
Duration
Mission Number

20 June 67
1119L
1845 L
5:30
BX 6705

STAT

2. DATE 20 June 67 TIME L/ 30

3. EXAMINATION: WEIGHT 183 TEMP 98.6 PULSE 88 RESP 20 B/P 140/80

- a. HEENT Clean
- b. CARDIOVASCULAR NSR
- c. RESPIRATORY Clean
- d. GENERAL Excellent physical status

4. PSYCHOLOGICAL EVALUATION Pilot in excellent spirits - feels mission was over.

5. DURATION IN SUIT 7:00

LIFE SUPPORT PROBLEMS None

6. SUMMARY AND FLIGHT SURGEON'S COMMENTS Mental Status Normal
No evidence of excessive stress or acute anxiety.

[Redacted Signature Box] MD

Flight Surgeon

Atch 4 to ANNEX E to
-----OPLAN

STAT

PREMISSION PHYSICAL EXAMINATION

STAT

1. NAME MISSION DATA: T/O Date 20 June 67
 T/O Time 1120L
 Primary Secondary B/U Expected Duration 5:00
 Mission Number BK 6705

2. DATE 19 June TIME H- 2300

3. RECENT HISTORY AND FAMILY HISTORY: No Change

4. SUBJECTS COMPLAINTS: None - Planter Weir @ foot and

5. REVIEW OF SYSTEMS: Essentially Negative

6. EXAMINATION: WEIGHT 184, TEMP 98°, PULSE 56, RESP 16, B/P 120/78

- a. HEENT Clean VNB
- b. CARDIOVASCULAR USR no @ or arrhythmias
- c. RESPIRATORY Clean to Auscultation

7. COMMENTS OF FLIGHT SURGEON ON ITEMS 3-6: Pilot is mentally and physically prepared for operational mission.

8. REPORT TO MISSION COORDINATOR: Date 19 June 67 Time 1245 L.
 Pilot Status A-Okay H- 2250

9. PRESUITING PHYSICAL CHECK: Time H- 1:40
 Temp 98°, Pulse 72, Resp 18 and B/P 126/78

ADDITIONAL COMMENTS BY FLIGHT SURGEON: Mental Status Normal -
No overt Signs or Symptoms of acute anxiety.
Good Sleep last night & adequate breakfast this AM.

ms
 Flight Surgeon

Atch 2 to ANNEX E to
OPLAN

STAT

1. NAME MISSION DATA: T/O Date 20 June 67 STAT
T/O Time ~ 1220L
Primary Secondary X B/U Expected Duration 5+00
Mission Number BK 6705

2. DATE 19 June 67 TIME H- 2250

3. RECENT HISTORY AND FAMILY HISTORY: No Change

4. SUBJECTS COMPLAINTS: None

5. REVIEW OF SYSTEMS: Essentially negative

6. EXAMINATION: WEIGHT 172, TEMP 97.2, PULSE 60, RESP 16, B/P 138/88

a. HEENT Clear UNB

b. CARDIOVASCULAR NSR no @ or arrhythmias

c. RESPIRATORY Clear to Auscultation

7. COMMENTS OF FLIGHT SURGEON ON ITEMS 3-6: Pilot is mentally and physically prepared for operational mission.

8. REPORT TO MISSION COORDINATOR: Date 19 June 67 Time 1245 L.
Pilot Status A-Okay H- 2240

9. PRESUITING PHYSICAL CHECK: Time H- 1:40
Temp 98.0, Pulse 68, Resp 16 and B/P 130/80

ADDITIONAL COMMENTS BY FLIGHT SURGEON: Mental Status Normal - No overt signs or symptoms of acute Anxiety - Good sleep last night + adequate breakfast this AM.

ms
Flight Surgeon

Atch 2 to ANNEX E to
OPLAN

Post-Mission P.E. not req. since 1^o pilot completed mission

TOH 1 to ANNEX E of DTF OPL 2-

FLIGHT SURGEON'S CHECK LIST

STAT

<u>H-HOUR TIME</u>	<u>LOCAL TIME</u>	
H-23:30	<u>1150</u>	Flight Surgeon will attend Commander's Briefing. Flight Surgeon will coordinate with Commander and DCO for selection of Mission Pilots.
* H-22:30 to H-21:30	<u>1250</u> <u>1350</u>	Pre-mission complete physical examination of pilots. Inform Mission Coordinator of results. Advise Aircrew Mess Supervisor of Messing and crewrest schedule.
H-21:30 to H-20:30	<u>1350</u> <u>1450</u>	Messing.
H-20:00	<u>1520</u>	Advise DCS name of Flight Surgeon on Recovery Team.
H-20:30 to H-18:00	<u>1450</u> <u>1720</u>	Recreation activities as scheduled.
H-18:00 to H-14:00	<u>1720</u> <u>2120</u>	Flight Surgeon will attend Intelligence Review and Initial Pilots' briefing. Extra time utilized in recreation activities.
H-14:00 to H-13:00	<u>2120</u> <u>2220</u>	Messing.
H-13:00 to H-12:00	<u>2220</u> <u>2320</u>	Preparation for bed. Relaxation.
* H-12:00 to H-4:30	<u>2320</u> <u>0650</u>	Sleep. <u>Inform Mission Coordinator when pilots go to bed.</u>
* H-4:30 to H-3:30	<u>0650</u> <u>0750</u>	Awake. Flight Surgeon evaluates pilots' psychological status. Breakfast. Transportation to briefing room.
H-3:45	<u>0735</u>	Coordinate with DCO for final selection of primary pilot.
H-3:30 to H-1:40	<u>0750</u> <u>0940</u>	Flight Surgeon will attend Final Pilots' briefing.
* H-1:40 to H-1:25	<u>0940</u> <u>0955</u>	Pre-suiting physical. Inform Mission Coordinator of results.
H-1:25 to H-1:05	<u>0955</u> <u>1015</u>	Suiting. Flight Surgeon standing by.
H-1:05	<u>1015</u>	Transport to aircraft. Flight Surgeon will accompany pilot to aircraft and standby until taxi.
H-Hour	<u>1120</u>	Takeoff. Flight Surgeon will standby in Ambulance until after takeoff and then keep DCS recovery team commander informed of his location until return landing of mission aircraft.
Landings to 1:25	<u> </u>	Desuiting and post-mission complete physical evaluation.
1:30	<u> </u>	Flight Surgeon will attend debriefing.

* Indicates contact with Mission Coordinator.

BX 6705

MISSION PILOTS ACTIVITY SCHEDULE FOR OPERATIONAL MISSION

<u>H-HOUR TIME</u>	<u>LOCAL TIME</u>	<u>ITEM</u>	<u>LOCATION</u>
H-22:30	<u>1250</u>	Pre-mission Physical Examination	Flt Surg Office
H-21:30	<u>1350</u>	Eating	Aircrew Mess
H-20:30	<u>1450</u>	Recreation activities as scheduled	Selected Area
H-18:00	<u>1720</u>	Intelligence Review	Intell Office
H-17:00	<u>1820</u>	Initial Briefing and Recreation	Briefing Room, Opns
H-14:00	<u>2120</u>	Eating	Aircrew Mess
H-13:00	<u>2220</u>	Crew Rest	Assigned House
H- 4:30	<u>0650</u>	Wake-up/Psychological Ck/Breakfast	Asgn House/Aircrew Mess
H-3:30	<u>0750</u>	Final Briefing	Briefing Room, Opns
H-1:40	<u>0940</u>	Final Physical Evaluation	Physiological Area
H-1:25	<u>0955</u>	Suiting	Physiological Area
H-1:05	<u>1015</u>	Leave Opns	Transport Van
H-1:00	<u>1020</u>	Arrive Aircraft	Hangar
H-:45	<u>1035</u>	Complete Loading	Aircraft
H-:15	<u>1105</u>	Taxi	Aircraft
H-:05	<u>1115</u>	Engine Trim	Aircraft
H-:00	<u>1120</u>	Takeoff	Aircraft
L+:25	_____	Post-Mission Physical Examination	Physiological Area
L+:30	_____	Opns Debrief	Briefing Room, Opns
L+:45	_____	Mission Debrief	Briefing Room, Opns
L+3:30	_____	Released	

BX 6705-

TOP SECRET

FROM: Mission Coordinator

19 JUNE 1967

SUBJECT: Mission Alert Notification

TO: (Sec below)

Request your attendance at the Commander's Briefing to be held in the Operations Briefing Room on 19 JUNE 1967 at 1150 L. The briefing concerns the following:

- 1. Mission Code Name and Number: BX 6705
- 2. Date/Time of Launch (H-Hour): 20 / 0220 Z / 1120 L.
- 3. Ground Spare (H+1:00): 20 / 0320 Z / 1220 L.
- 4. ~~General Area of Operation~~ N/R
- 5. Bases: Takeoff KADENA, Staging -, Landing KADENA.
- 6. Equipment required: TYPE I, BW, PIN PEG, BIG BLAST, BLUE DOG II, SIP on system
- 7. Ground Spare Requirements: SAME AS Pri. where POSSIBLE.
- 8. Special Instructions/Comments: LAUNCH BACK UP AT 1220L IF Pri ABOYTS. BX CANCELED Mission #8.

FOR THE COMMANDER

Mission Coordinator

Office	Time (L)	Recipient	Office	Time (L)	Recipient
CMDR	_____	_____	DCOL	_____	_____
DCO	_____	_____	DCOC/MC	<u>0720</u>	<u>Rnd</u>
DCM	_____	_____	DCOMI	_____	_____
DCS	_____	_____	DCOW	_____	_____
SECUR	_____	_____	COMMO	_____	_____
FLT SURG	_____	_____	AEC5	_____	(Notify Only)
DCOM	_____	_____	TTC(SAC)	_____	(Notify Only)

BX 6705

-Minus	ACTION	DOI REF	Pers- Resp Int	Time Due Zulu	Time Due Local	Time Done Local	Done By Int
-4:00	SEND R-243	B-18	FPW	19/2220	20/0720	0658I	JPW
-3:30	Brief pilots and Ops Staff	B-20	DEB	2250	0750	0750I	DEB
	<i>Brf Tankers</i>		JY	2255	0755	0800	JY
-3:00	REC R-235 AMEND (Msn Wx Data)	B-11	DEB	2320	0820	0750	RH
-2:30	MO mans CP and Posts Data	B-13	RAH	2350	0850	0730	RH
-2:00	REC R-240	B-22	DEB	20/0020	0920	<i>0926</i> 0935	DEB
-1:50	PICK UP E2 APT PIX		DGM	0030	0930	0940I	JY
-1:40	MF replaces MO in CP	B-13	DEB	0040	0940	0935I	DEB
-1:35	Letdown Plate Posts to Pilot (Notify Mission Coordinator)	B-14	DEB	0045	0945	0910I	DEB
-1:30	Notify DCOL (Need to rebrief)	B-7	DEB	0050	0950	0945I	DEB
-1:10	Rebrief Pilots if Necessary	B-20	DEB	0110	1010	0945I	DEB
1:40	PICK UP NZ APT PIX		DGM (2 nd FSTB)	0500	1400	NZ no good	
4:45	Attend Pilot Debriefing	B-15	DEB	0820	1720	1720I	DEB
1:00	Return Met Watch to Station	B-13		0800	1700	1700I	DEB
24:00	Turn in Mission Data	B-17		21/0745	21/1645	22/1530I	DEB



STAT
STAT
STAT

"H" HOUR 0220 Z 1120 L BLACK SHIELD CHECKLIST MSN DATE: 20 JUN 67
 "L" HOUR 0715 Z 1615 L (With Tankers) (01 Jun 67)

MSN NR BX6705 CODE NAME BLACK SHIELD MSN COORD [redacted] MSN DCOM COORD [redacted]
 MSN STFC [redacted]

CHASE PILOT [redacted] A FCSTR [redacted] DUTY HOURS 19/1100-2000I ; 20/6500-1800I
 MSN PILOTS LAYTON B FCSTR [redacted] DUTY HOURS 19/1500-1900I ; 20/0530-1230I
 131 VOJDO DICH A OBSVR [redacted] DUTY HOURS 19/2200-20/0830I
 B OBSVR [redacted] DUTY HOURS 19/1100-2300I ; 20/0700-1630I
 DUTY HOURS 19/2300-20/1000I

H-MINUS	ACTION	DOI REF	RESP INT	TIME DUE ZULU	TIME DUE LOCAL	TIME DONE LOCAL	DONE BY INT
-24:00	Start this checklist	B-3	DEB	19/0220	19/1120	0735I	JY
-24:00	Arrange work schedules	B-4	DEB	0220	1120	0930I	DEB
-23:00	Attend Commanders briefing	B-1	DEB	0250	1150	1150I	DEB
-23:00	Rec R-232 (Prelim Ops Data)	B-1	DEB	0320	1220	0555I	
-22:30	COORDINATE TFC SUPPORT	B-9	DEB	0350	1250	1330I	DEB
-21:00	REC R-236A	B-5	DEB	0520	1420	1357I	DEB
-21:00	Start Wx Sta. Met Watbh Log	B-21	DEB	0520	1420	1400I	DEB
-21:00	REC R-233 (Msn Wx Data)	B-6	DEB	0520	1420	1357I	DEB
-20:30	PICK UP APT PICTURES		DEB	0530	1430	NZ no work signal	RH
-17:30	REC R-233 Amend (Msn Wx Data)	B-6	DEB	0850	1750	1654I	RH
-17:15	REC R-236B	B-5	DEB	0905	1805	1654I	RH
-17:00	Brief Pilot and Ops Staff	B-7	DEB	0920	1820	1820I	DEB
-15:00	Rec R-234 (Final Ops Data)	B-8	JY	1320Z 1720	2230I 2020	2250	RH
-14:00	REC LETDOWN PLATES FM DCOM		JY	1220	2120	1700I	DEB
-14:00	Rec R-237 (Tanker Wx Data)	B-9	JY	1220	2120	1950I	DEB
-13:30	GIVE PRELIM DATA to TFC	B-9	JY	1250	2150	2110I	JY
-10:00	Send R-236C	B-5	JY	1620	20/0120	0105I	JY
-9:00	Rec R6235 (Msn Wx Data)	B-11	JY	1720	0220	0130I	JY
-9:00	Give R-86 Input to Msn Cord	B-23	JY	1720	0220	0105I	JY
-8:00	Send R-241 (If required)	B-16	JY	1820	0320		
	Brf Tankers		JY	2135	0635	0640I	JY
-4:00	Send R-236D	B-5	JY	2220	0720	0700I	JY

TOP SECRET

WEATHER DEBRIEFING FORM

50X1

1 COMPLETE BEFORE DEBRIEFING:

ARTICLE # 129 PILOT LAYTON DEBRIEFING TIME 1720 L DATE 20 JUN 67

FLIGHT # ²¹⁷ BX6705 ROUTE BS #8 WEA BRIEFED BY

TAKE OFF TIME 1119 L OB 200 RT 82°F WIND 2310 PA +330

LANDING TIME 1645 L OB 200 450 320 20 WIND 2112 G 18

WIND DRGTH. V. BL 190-230

SPECIAL DEBRIEF ITEMS _____

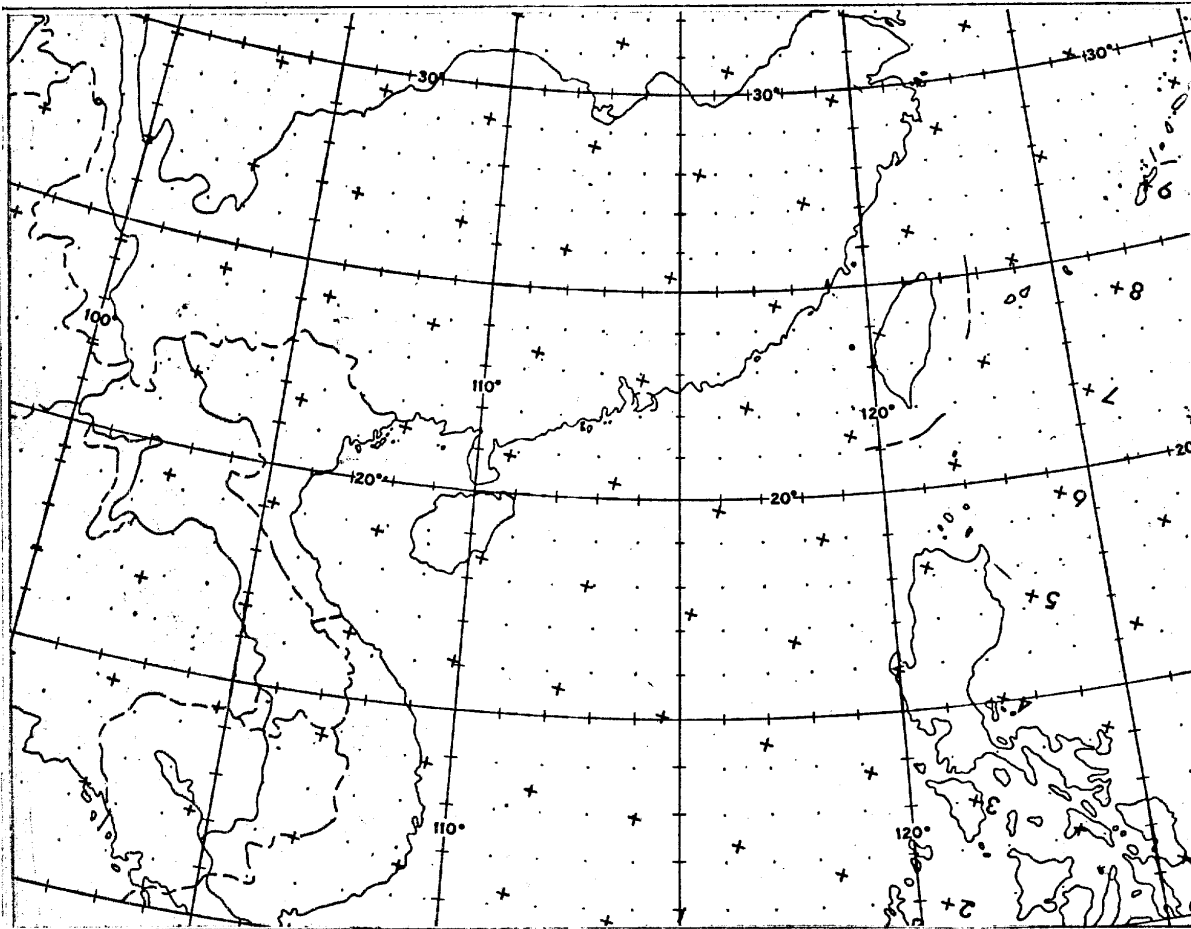

2. COMPLETE DURING DEBRIEFING

MISSION WAS (SUCCESSFUL) (UNSUCCESSFUL DUE TO _____)

MAX MACH 3.15 MAX ALT 82M TIME ABV 50M 245 MAX CIT 380 AT 3.10

TURBULENCE DETAILS:

INTENSITY	ALTITUDES	LOCATION	A/C SPEED	HEADING	ATTIT
<u>LGT</u>	<u>40-55M</u>	<u>↗</u>	_____	_____	_____
<u>None at cruise</u>	_____	_____	_____	_____	_____
_____	_____	_____	_____	_____	_____

ACTUAL WEA WAS ESSENTIALLY AS BRIEFED EXCEPT 99% Clear entire target
WEA DEBRIEFED BY: Maj R

R-111
10x as fast?

R-118
1 CLR
2 ✓
3 ✓
4 ✓
5 ✓

TOP SECRET

Declassified in Part - Sanitized Copy Approved for Release 2013/06/12 : CIA-RDP69B00041R000200040001-2

STN	CKT	OBSERVATION	OBSERVATION	FORECAST	FORECAST	RNY	X-WND	NOTAM	COLOR
		078	1711						
AOZNA	931	250/012 2315	250/012 2315						
JAKA	930	250/012 2315	250/012 2315						
									STAT
CK	770	250/012 2315	250/012 2315						
AOYUAN	697	250/012 2315	250/012 2315						
TAMHAN	743	250/012 2315	250/012 2315						
CHIA-1	746	250/012 2315	250/012 2315						
HSIN-CHU	756	250/012 2315	250/012 2315						
YAKUNG	734	250/012 2315	250/012 2315						
FAKHI	VTBI								
DANNING	VVSD								
BIEH-HUA	VVGH								
TAN-SON NHUT	VVVS								
LAN-KAN BAY	VVCR								
DOAN HUANG	VTBD								
KOKAT	VTUN								
V-TAHO	VTBU								
MUANG UBON	VTUU								
UDON	VTUP								
CHIANG-MAI	VTCL								

Declassified in Part - Sanitized Copy Approved for Release 2013/06/12 : CIA-RDP69B00041R000200040001-2

Declassified in Part - Sanitized Copy Approved for Release 2013/06/12 : CIA-RDP69B00041R000200040001-2

STN	CKT	OBSERVATION	OBSERVATION	FORECAST	FORECAST	RNY	X-WND	NOTAM	COLOR
KADENA	931	200220020 2212018	200330020 2310015	200330020 2410	200330020 2112018				
NAHA	930	200400220010 2212	200400220010 2311	200/010 2312	250/010 2411				
		300/015 1801	350/015 1208 TCU S&W	350/015 1201 120	400/015 1607 CB S-W TCU ALGDS				STAT
CKK	770	120250/08 2134	120250/08 2314	250/08 2314	250/08 2415				
TAOVAN	697	250120/010 2518	250120/010 2518	250120/010 2518	250120/015 2520030				
TAINAN	743	220/010 2506		200/010 2309	200/010 2510				
CAHA-1	746	250/010 2110	250/010 2206	250/010 2108	250/010 2410				
MSN-LAW	756	200/010 2320	200/010 2322	1010 2422	1010 2422				
MAKUNG	734	80210/07 1812	80210/07 1812	901810/08 1812	901810/08 1812				
TAKKI	VT81	1010 1803		300/015 0504	300/0 CALM				
DANANG	VNSD	1-025 CALM	350/025 0206		350/020 0207				
BIEN-HOA	VNDH	230100/01700/020 2310	270100/01700/020 2209 CB/TCU/RWU NNE TCU/ALGDS	300100/01700/030 2207	3501700/020 2507 CB R RWU W-N-NE TCU/ALGDS				
PHU THUAN	VNVS	2001300/012 2510	2301500/012 2407	1702300/011 2410 RWU CB NE 2300	1702700/01300/011 2510 CB R RWU W-N-NE				
PHU THUAN	VNCR	1-020 1803	1-020 0803 TCU		400/020 0910015				
PHU THUAN	VT60	3001200/012 2205 CB SE		300/012 2506	250/012 2404				
PHU THUAN	VTUN	1020 2705		300/025 3004	300/025 2404				
PHU THUAN	VT60	GRBLD		2501200/012 2511	2501200/025 2108 CB SE				
PHU THUAN	VTUU	1-015 2504		200/015 2505	300/015 2408 CB SE				
PHU THUAN	VTUO	CLR 12 2902		25012 2507	25012 2507 TCU				
PHU THUAN	VTCC	3509 1705	35010 1804	300/010 2108	300/010 2108 ALGDS TCU ALGDS VNSA D				

Declassified in Part - Sanitized Copy Approved for Release 2013/06/12 : CIA-RDP69B00041R000200040001-2

STN	CKT	OBSERVATION	OBSERVATION	FORECAST	FORECAST	FRY	X-WND	NCTAM	COLOR
931		100300Z220010 2207	130000Z220010 2207	180000Z220015 2207	2000200020 2310				
930		200400Z220017 2209	200400Z220017 2211	200400Z220017 2211	200400Z220017 2212				
		1-012 CALM			250/015 CALM				STAT
770		100107 1810	150000Z 1814	150007 1814					
697		120007 2416	120000Z 2510	120003 2516					
743		2001056F 0906	200200Z 56F 1207	220107 1805	220108 2408				
746			230000Z 1810	230100 1808	250100 2108				
756		10010 2312	20000 2310	10010 2310					
734		200107 1808	200200Z 1810	20015007 1810	20010007 1812				
VTBI				1015 1717 TCU					
VTSC				1-025 1000	CLR 21 2306				
VTBH		12-0220/010 2400 (TCU/010-)		150000/010 2405	170100/010 2307				
VNS		70170300/300/0500- 2311 (CB)		1301012 2007	1701012 2210				
VYCK		1-020 3038 (CB)		1-020 CB 2010					
VTGD				250120010 2405 CB:					
VTUN			1000/012 2105	1015 210					
VTBV			1012 2104	1025 2104 TCU					
VTUD			2001015 2207	2001015 2205					
VTVD				CLR 13 CALM					
VTCC					3509 CALM				

1120 89
38
1158

STN	CKT	FCST OBSERVATION	FCST OBSERVATION	FORECAST	FORECAST	RNY
RODN	931	120300150@230@10 2/18/61 CB VNTY	150300150@200@10 25 12620	150300200@10 2310615 CB/RW 13-19Z	2001200300@10 2210	
ROAH	930	Same as above CB VNTY	"			
ROAH	770	200100@300@7 18/10 CB VNTY	400300@10 9908 CB VNTY INTER 300@5 RW- 9910615 150250300@7 2415620 INTER SRW	350300@10 1508 (OB) INTER 300@5 RW- 9910615 250750@7 2316		STAT
ROCM	697	250300@7 25/12620	250300@10 2418625	250300@8 218628		
ROCN	743	300300@7 14/10				
ROCK	744	250300@7 22/10	220300@7 2150	250300@7 2315		
ROCP	736	200300@7 23/15	200300@10 2370	200300@10 2320		
ROCC	734	250300@7 18/09	250300@7 1810	250300@7 1810		
ROBT		300100@300@7 15/05 CB S-W 06-13Z	300120@300@7 2005 RW/TRW VNTY 350250@7 1408 CB VNTY	300250@7 2425 (RW/RW) 950280@10 1100 RW/TRW S-W		
ROVH		350300@7 14/08 INTER 06-10@1/2 TRW 24/10615 200100@300@7 2405 INTER 00-06@ 24/10 110625	200100@300@7 2405 INTER 00-06@ 24/10 110625	200100@300@7 2310 INTER 06Z 10@ 1/2 TRW 9925		
ROVW		200100@300@7 2410 Same as VVBA above CB VNTY	200120@250@7 2410 INTER 06Z 10@1 TRW 9915630 300300@15 1210615 CB VNTY	200130@300@7 2610615 200V@ INTER 06Z 5010@1/2 TRW 9915625 700705 1708		
ROVY		300300@15 12/10615 CB VNTY	250120@300@10 2110 CB/TRW/RW VNTY	300300@15 1708 CB/RW 300120@300@10 2205 300150@300@7 9905		
ROTD		250120@300@10 21/05 CB VNTY	250900250@10 2210 CB VNTY	300120@300@10 2205 300150@300@7 9905		
ROTH		300800300@7 23/05 CB VNTY	200100@300@10 2110 RW VNTY	300120@300@10 2205 300150@300@7 9905		
ROTR		200120@300@15 18/10 CB VNTY	300V@ 300@10 2207 CB VNTY	300120@300@10 2205 300150@300@7 9905		
ROTV		300100@300@10 22/07 CB VNTY	300300@7 9905 INTER 06Z 300@1 TRW	300300@10 9905 (CB/TCU)		
ROTC		200100@300@7 20/10 INTER 10@1/2 TRW				

STN	CNT	16Z OBS OBSERVATION	17Z OBS OBSERVATION	18Z FORECAST	19Z FORECAST	20Z OBS OBSERVATION	21Z OBS OBSERVATION	22Z FORECAST	23Z FORECAST
931		380100022005 2110	380100022005 2210	220-013 2207	220-013 2207	500250105F 2207	500200105F 2100	603000/010 2207 (60 IN AREA)	G
930		8001000 2110	8001000 2109	8001000 2211	2400800/05F 2311	500250105F 2207	500200105F 2100	120200400/07 2208	G
		1500800/05 190012 1804	650190010RW-2006	650200012 2002 CB & S	6501-012 CALM	6501-012 CALM	N	6501-012 3202 (TEU)	G
710		NODAT	3001000 7 1812	3001000 7 1810	NODAT	EXP 300 7 1808	NODAT	NODAT	G
		1000100 7 2302	1000100 7 2103	1000100 7 2302	1000100 7 1802	1000100 7 1803	5001000 7 2109	1601000/07 2410	G
		25007 1606	25007 1207	25007 7 1206	25007 7 1209	25007 CALM	200500 0806		Y
		NODAT	100 7 1806	NODAT	100 7 1806	100 7 1805	NODAT	NODAT	G
		100 7 2010	100 7 2310	100 7 2312	100 7 2310	100 7 2310	100 7 2315	2001000 2315	G
		100 7 1808	100 7 1808	100 CRW- 1807		100 7 2210	NODAT	2001000 2008	G
		1200100 7 1404	1200100 7 1605	100 7 1509	100 7 1609	100 7 1702	100 7 1509	100 7 1602	G
		CLR12 2203	1-025 CALM	1-025 CALM	1-025 CALM	1-027 CALM	1-027 CALM	1-025 CALM	G
		12001-07 CALM	100 7 CALM	100 7 CALM	20-01000/07 CALM	21001200/07 CALM		1202000/2000/07 CALM	G
		5001500/006 2206	5001500/006 2206	5001500/006 2207	5001500/006 2206	5001700/006 2206	5002000/006 1700/006 2206	5001500/006 2007 (CB)	G
		CLR 20 3006 LNCB & S-SW	CLR 20 3009 LNCB & S	CLR 20 3209 LNCB & S	CLR 20 3307 CB & SE-S	CLR 20 3209 CB & SE	CLR 20 3305 CB & SE-S	1-020 2803 (TEU)	G
		3001500/2000/08 1602	4501100/1008 CALM	3001000/08 2009	3001200/08 1902 CB & N & SW	25001200/08 CALM	25001200/08 CALM	3001200/08 2103	G
		8001-012 2009	10001-012 2007	100010010 2205	100010010 2207 & S-SW		100 7 2105	1-010 2107	G
		1200100 7 1906 CB & DSNT 550	1800800/012 1910 TCU SW	1800800/012 2408		9001-012 3003 CB & N	9001-012 3103 & N-N	9001-012 2803 (S)	G
		10001-015 2202	1-015 CALM	1-015 2109	1-015 2105	1-015 2105	CLR15 2109	10001-015 2202 (CB)	G
		14001-009 CALM CB & DSNT NCF SE	1-009 1402	14001-009 CALM	1-009 CALM	1-009 CALM	CLR 9 1202	CLR 9 CALM	G

N

ZCZC100FTX183/''''''/200515Z ZFF-1 ZPO



50X1

BT

XXXXX

OPCEN 010



50X1

T O P S E C R E T 200515Z CITE WECEN 2104

0088

JJJJJSSSSSFLASH ADIC,



50X1

REALM-240

A.



50X1

1111

T O P S E C R E T

BT

701 1424 I

[Handwritten signature]

[Handwritten signature]

20 JUN 67 05 10Z

NNN

N

Page Denied

TOP SECRET 191607Z CITE VECEN 2088

IMMEDIATE ADIC, [REDACTED]

REALM 235

A. BX6705

B. 20/3344Z TO 8626Z JUNE 67.

C. NO SIG CHG, EXCEPT CAT YE IN CU C [REDACTED] BRIDGE FROM 20
TO 15N.

D. BRN CI 250/350 TO 20N WITH ISLT [REDACTED] BRN CI 2 [REDACTED]
19N; CAT II IN CU AND CI TO MTN RIDGE [REDACTED]. NO SIG CHG OR RETURN

E. SURE HIT: 6/8 CI CS 280/350, 2-4 [REDACTED] 27/15051, ISLD CB TO [REDACTED]
NORTH OF A/R, 353/660.

STEEL BRIDGE: 4/8 CI 300/350, [REDACTED] ISLD CB TO [REDACTED]
WEST OF A/R, 370/670.

F. 417 DATA AVAILABLE FOR [REDACTED] AT APPROX 0140Z AS [REDACTED]
TELE [REDACTED]

TOP SECRET

BT

50X1

50X1

20/07 30I
AY
De

R-235
WECEN 2088

NNNNZCZC091FTX180''''''/200349Z ZFF1 ZPO

50X1

BT

XXXXX

OPCEN 010

50X1

20034

20 JUN 67 03 51z

T O P S E C R E T 200348Z CITE WECEN 2102

FLASH ADIC,

50X1

REALM 240

A.

50X1

B. 1311

*20/0 353Z
JFB*

T O P S E C R E T

BT

NNNN

NNNN YZCZC085FTX176''''/200159Z ZFF1 ZPO

50X1

BT

XXXXX

OPCEN 008

50X1

20281

20 JUN 67 02 01z

T O P S E C R E T 200158Z CITE WECEN 2099

FLASH ADIC,

50X1

REALM 240

A.

50X1

B. 1511

20/0205Z GEB

T O P S E C R E T

BT

NNNN

ZCZC079FTX174''''''/200015Z ZFF1 ZPO

50X1

BT

XXXXX

OPCEN 007

50X1

20276

T O P S E C R E T 200050Z CITE WECEN 2098

FLASH ADIC,

50X1

REALM 240

A.

50X1

B. 6111

T O P S E C R E T

BT

20 JUN 67 00 53z

*20/00578
WLB*

NNNN

20 JUN 67 00 39z

ZCZC076FTX173/''''''/200036Z ZFF1 ZPO

50X1

BT

XXXXX

OPCEN 006

50X1

00271

T O P S E C R E T 200035Z CITE WECEN 2097

FLASH ADIC,

50X1

REALM 240

A.

B. 6512

50X1

*20/0042z
for P*

T O P S E C R E T

BT

ZCZC075FTX172''''''/200034Z ZFF1 ZPO

50X1

BT

XXXXX

OPCEN 005

50X1

20270

T O P S E C R E T 200033Z CITE WECEN 2096

20 JUN 67 00 37z

FLASH ADIC,

50X1

REALM 240

A.

50X1

B 1111

A.

50X1

B. 1513

T O P S E C R E T

BT

*20/00412
WEL*

NNNN

20910

TOP SECRET 192141Z CITE WECEN

IMMEDIATE ADIC,

REALM 235 (AMD)

A. BX6785

B. 20/2344Z TO 2626Z JUN 67

C. NO SIG CHG. POSSIBLE BETTER

D. NO CHG

E. NO CHG

F. N/A

TOP SECRET

BT

50X1

*19/0750 I
RAH
DeB*

*R-235 (AMD)
WECEN 2093*

TOP SECRET 192200 CITE
IMMEDIATE ADIC WECEN
OXCART BLACK SHIELD WK OPS
REALM 256 (D)
A. BX 6705
B. 20/0220Z TO 0815Z JUNE 67
C. RODS, ROAN: NO SIG CHANGE
RPMK: NO SIG CHANGE
RCGM: NO SIG CHANGE
VTBI: NO SIG CHANGE
VTBU: NO SIG CHANGE
TOP SECRET
BT



0750Z
RAK

JEB

R-236(D)



50X1

50X1

ACTION: IMMEDIATE

FROM:

50X1

TO: ADIC, WECEN

OXCART/BLACK SHIELD/WX/OPS
REALM 236 (D)

A. BX 6745

B. 20/0220Z TO 0815Z JUNE 67

C. RODN, ROAH: NO SIG CHANGE

NO SIG CHANGE

STAT

RCGM: NO SIG CHANGE

VTBI: NO SIG CHANGE

VTBU: NO SIG CHANGE

END OF MESSAGE . COORD:

50X1

RELEASER

10/0657L
DATE/TIME

T O P S E C R E T 19215 CITE [redacted]

50X1

IMMEDIATE ADIC INFO IMMEDIATE WICEN

OXCART BLACK SHIELD WX OPS

REALM 243

A. BX 6705

B. 19/2100Z

C. RODN 174V BRKN 45 OVC 4F 2308 CIG 3VB

ROAH M5 BRKN 20 BRKN HI BRKS 5F 814.5 ERKN V SOTD

RCGM 52 SOTD HI BRKN 7 2104

VTBI HI INN SCID 7 1504

VTBI 90 SOTD HI INN BRKN 12 3103 ONL DENTY LTG N-NE

[redacted] 35 SOTD E65 BRKN HI BRKN 12 TALK

STAT

T O P S E C R E T

BT

*0750 I
RHM*

DAB

R-243

NNNN

TOP SECRET

ACTION: IMMEDIATE

INFO: IMMEDIATE

FROM:

50X1

TO: ADIC

INFO: WECEN

OXCART/BLACK SHIELD /WX/OPS
REALM 243

A. BX 6705

B. 19/2148Z

C. RODN 174V BRKN 45 OVC 4F 2308 CIG 3V5

ROAH M5 BRKN 20 BRKN HI BRKN 5F 2106

5 BRKN V SCTD

RCGM 50 SCTD HI BRKN 7 2104

VTBI HI THN SCTD 7 1504

VTBU 90 SCTD HI THN BRKN 12 3103 UCNL

DSNT LTG N-NE

35 SCTD ELS BRKN HI BRKN 12 CALM STAT

END OF MESSAGE

50X1

19/2148Z

50X1

DATE/TIME

TOP SECRET

T O P S E C R E T 191600Z CITE



50X1

IMMEDIATE ADIC, WECEN

OXCART / BLACK SHIELD / WX / OPS

REALM 236 (C)

A. BX6705

B. 20/0220Z TO 0815Z JUNE 67

C. RODN, ROAH: 12 SCD 30 SCD 150 BRKN 230 BRKN 10 230/08G12

RW- FAP 04-08Z, NIL RPMK: 40 SCD 300 SCD 15 99/07 CB VCNTY 06-28Z

RCG.: 25 SCD 300 BRKN 7 250/12620, NIL

VTBI: 30 SCD 100 SCD 300 BRKN 7 130/05, NIL

VTBU: 20 SCD 120 SCD 300 BRKN 15 130/10 CB VCNTY 02-08Z, NIL

T O P S E C R E T

BT

20/0130E

R-236(C)



9:1
DWB

NNNN

50X1

TO: DIRECTOR, HEADQUARTERS

FROM:

50X1

TO: ADIC, MESSINA

ORCHARD/BLACK SHIRT/WX/OPS
REMI 236 (C)

A. BX6705

B. 20/0220Z TO 0815Z JUNE 67

C. RODN, ROAH: 12 SCTD 10 SCTD 100 BRKN

230 BRKN 10 20/0100G12 RW-PAI 04-08Z, NIL

RPMK: 40 SCTD 300 SCTD 15 99/07

CB VNTY 04-08Z

RCGM: 25 SCTD 100 BRKN 7 20/1200Z NIL

VTBI: 30 SCTD 100 SCTD 300 BRKN 7 150/05, NIL

VTBU: 20 SCTD 100 SCTD 300 BRKN 15 180/10

CB VNTY 02-08Z, NIL

END OF MESSAGE (C) :

Handwritten signature

50X1

20/0105 L

20/0105 L

NNNN

ZCZC024

191/191243Z ZPT

BT

XXXXX

[Redacted]

WECEN 536

50X1

19 JUN 67 12 51z

232

T O P S E C R E T 191237Z CITE ADIC 2803

IMMEDIATE [Redacted] WECEN

50X1

REALM-234

A. BX6705

B. 20/0344Z TO 0626Z JUNE 67

C. THRU E. NO CHANGE FROM REALM-232 (CANNED RTE NBR 8)

F. [Redacted] ADD UTAPOA ON REALM-236C AND D.

50X1

G. WECEN: REALM-235/IMMEDIATE [Redacted] ADIC/NLT 19/1620Z; REALM-235

50X1

AMND/ IMMEDIATE [Redacted] ADIC/NLT 19/2220Z.

50X1

H. NOTE: [Redacted] AND WECEN: AMND RCM TO REFLECT REALM-234 DUE ADDEE

50X1

TIME TO 1330Z. THIS TIMING NECESSARY SINCE HQ BRIEFING IS

HELD AT 1200Z, REGARDLESS OF ETD OF MSN.

T O P S E C R E T

BT

19/2156Z GELB
19/19

R-234

ADIC 2803

NNNN

XERO COPY

XERO COPY

XERO COPY

WEATHER DATA

DATE: 19 June 61 TAKE OFF TIME: 19/2335Z/0195Z

TAKE OFF DATA

RUNWAY TEMP _____ °F SIC WIND 23/15.520

PRESSURE ALT 4250 FT CDS, VIS 250 1200 2000 7

110-1CB VCNTN

CLIMB WINDS See 1237 CRIME TEMP DEVIATION +10 °C

TURBULENCE See 1237

ENROUTE WEATHER (CLOUDS, TURBULENCE, ICING, STATE OF SEA)

See 1237

ENROUTE WINDS

See 1237

AAR(s) FORECAST (CLOUDS, TURBULENCE, ICING, WINDS, ETC)

See 1237

PRIMARY AND ALTERNATE LANDING FORECASTS

STATION	VALID	FORECAST
TRACAP	0000Z	400 10 34/08
	1200Z	
	0000Z	400 10 34/08 29.70
	1200Z	INSTR 7-12+ 40 @ 5 TRW
CCR	0000Z	250 10 5H 10/10 29.74
	1200Z	"
TRACAP	0000Z	300 10 5H 10/10 29.73
	1200Z	"
TRACAP	0000Z	200 10 250 10 10/10 29.67

50X1

/191010Z ZFF3 ZPO

50X1

BT

XXXXX

[] OPCEN 997 []

50X1

19 JUN 67 10 42z

231

T O P S E C R E T 191005Z ~~191005Z~~ 191005Z ~~191005Z~~ WIKEN, 2079

IMMEDIATE [] ADIC, []

550X1

REALM-237

19/1950L
[Signature]

A. BX6705

B. SURE HIT: 5/8 CI-CS 280/350, 2-4, 270/15M33, ISLD CB TO 400 VCNTY, 380/660.

STEEL BRIDGE: 6/8 CI 300/350, 7, 090/10M33 ISLD CB TO 450 VCNTY, 370/670.

C. KADENA TO SURE HIT: CLIMB (35M)-260/25M02; TO 25N 280/15M32, TO A/R 270/15M33; RETURN ROUTE TO KADENA: 30-35M NO CHANGE, 43M: 020/25M63, SIG WEA ENROUTE: 5-6/8 CI-CS BASES 230 RODN-280 AR, TOPS TO 350, ISLD CB TO 400. KADENA TO STEEL BRIDGE: CLIMB (35M)-260/25M02; TO 25N 280/20M32, TO 23N 280/15M33, TO 19.24N, 116.12E: 120/10M33, TO 110E: 100/10M33, TO 105E: 080/05M33, TO A/R: 080/05M33; RETURN TO KADENA (30-35M) NO CHANGE, 43M: END AR TO 17N 99-42E: 080/30M63, TO 105E: 080/30M63, TO 110E: 080/20M63, TO 115E 080/20M62, TO 22N 090/25M62, TO 24N: 030/20M63, TO KADENA: 020/30M63, RETURN TO TAKHLI (30-35M) 090/10M33, SIG WEA ENROUTE: RODN TO 24N 6/8 CI-CS 230/LYRD/350, ISLD CB TO 400, TO 19N: 5/8 CI 280/350, TO 105E: 4/8 CI 300/350, TO A/R: 5-6/8 CI 300/350 ISLD CB TO 450, RETURN SAME, 43M RETURN ISLD CB TOPS TO 450 TO 105E, RMDR NO SIG.

[Signature]

D. NOT REQUIRED.

T O P S E C R E T

BT

NNNNZCZC007FTX137/190743Z ZFF-3 ZPO

50X1

BT

19 JUN 67 07 47z

XXXXX

OPCEN 995

50X1

00228

T O P S E C R E T 190735Z CITE WECEN 2076

IMMEDIATE INFO IMMEDIATE ADIC

50X1

REALM-236B

A. BX 6705

B. 20/0344Z TO 0626Z JUNE 67

C. KADENA-NAHA: 2-4/8 CU 25/100 4/8 AC 120/150

6/8 CI-CS 230/LYRD/350, 7, 230/15G20, FL160, ISLT CB/RW

VCNTY, 380/660

BAN TAKHLI-NO SIG CHG

NO SIG CHG

50X1

TAO YUAN: ADD 5/8 CI 280/350 REST SAME

U TAPAO: NO SIG CHG

T O P S E C R E T

BT

*0754Z
PH
qsb*

R-236B

w ECEN 2076

FIVER

KRRZCZC006FTX136/190735Z ZFF-3 ZPO

50X1

BT

XXXXX

OPCEN 994

50X1

19 JUN 67 07 46z

2027

T O P S E C R E T 190735Z CITE WECEN 2075

IMMEDIATE INFO IMMEDIATE ADIC

50X1

REALM-233 AMD

A. BX6705

B. 20/0344Z TO 0626Z JUN 67

C. CAT THREE IN CU-AC-CI SOUTHEAST OF 22030 21517 21809 221/10.5
22209 221.6/07 22205 220/05.5 21806 21608 214/08.5 21209

21011 CAT TWO IN CU-CI WITHIN 220/09.5 22110 221.5/08 221.7/05.5
220/05.6 21906 215.7/09 21909 220/09.5 RMDR SAME

D. A/R FCSTS SURE HIT: 5/8 CI-CS 280/350, 2-4, REST SAME
STEEL BRIDGE NBR 1 AND 2: NO SIG CHG

E. OUTLOOK FOR FOLLOWING 24 HRS IS FOR NO SIG CHG. CLD
COVER IS EXPECTED TO REMAIN BKN THIN CI WITH 1-2/8 LOW
CLD. BASIN WILL REMAIN CAT TWO WITH CAT THREE IN SURROUNDING
MTS.

T O P S E C R E T

BT

*07513
H44* *WCB*

R-233 AMEND
WECEN 2075

Page Denied

NNNNZCZC999FTX129

/190438Z ZFF3 ZPO



50X1

BT

XXXXX



OPCEN 993

19/1357 L
AD

19 JUN 67 04 46z

50X1

20225

T O P S E C R E T 190433Z CITE WECEN 2073

IMMEDIATE  INFO IMMEDIATE ADIC

50X1

REALM-236A

A. BX6705

B. 20/0344Z TO 0626Z JUN 67.

KADENA: 2-4/8 CU 25/100 4/8 AC 120/150 6/8 CI-CS 230/LYRD/
400, 7, 230/15G20, FL160, ISLD CB/RW VCNTY, 380/660.

NAHA: SAME AS KADENA.

BAN TAKHLI: 3/8 CU-SC 20/100 2/8 AC 120/150 6/8 CI 300/350,
5H-7, 200/10, FL160, CB/RW VCNTY, 370/670.



50X1

TAO YUAN: 2/8 CU 25/60 6/8 AC 100/120 7 V/05, FL150, 380/650.

U TAPAO: 3/8 CU 20/80 2/8 AC 120/150 6/8 CI 300/350, 5H-7,
210/10, FL160, RW VCNTY, 370/670.

T O P S E C R E T

BT

TCH

R-236A
WECEN 2073

NNNN

ZCZC998FTX128

/190431Z ZFF3 ZPO



BT

XXXXX



OPCEN 992

19/1357L
du

19 JUN 67 04 46z

50X1

50X1

T O P S E C R E T 190429Z CITE WECEN 2072

IMMEDIATE



INFO IMMEDIATE ADIC

30221

50X1

REALM-233

A. BX6705

B. 20/0344Z TO 0626Z JUN 67.

C. CAT II-III IN CU-SC, CI SOUTH OF 21809 21902 220.5/10.3
221.5/08.5 22107 221.3/05.8 220/05.7 21806 215/08.6 CAT FOUR IN
ST BCMG CAT TWO-THREE IN CU BY 0400-0500Z SOUTH OF 2213/06.2 22206
221.705 220/05.6 CAT THREE CU-AC-CI SOUTHEAST OF 21020 21525 21630
RMDR CAT FOUR-FIVE.

D. A/R FORECASTS: SURE HIT 6/8 CI-CS 280/LYRD/400, 2-4, 300/20,
ISLD CB TO 400, 380/660.

NBR 1 STEEL BRIDGE 6/8 CI 300/350, 7, 140/10, CB TO 450,
370/670

NBR 2 STEEL BRIDGE NO SIG CHN FROM NBR 1.

E. CAT TWO IN HANOI BASIN PREDICATED UPON CAMERA SEEING THRU THIN
CI, SFC DATA INDICATES 1-3/8 COMBINED LOW, MIDDLE CLD AND 5-7/8
THIN CI. 417 INFO SHOWS CI IS VERY THIN.

T O P S E C R E T

STEEL BRIDGE 1

Brfg 0635I
T.O. 0835I, 36, 37

All land U-Tapao
5+50 to U-Tapao
2 hr on ground
4+00 back to Kadema

YT ste to Danang - Diversion Rte to UBON - Direct to begin A/R

ACFT

071

089

1504

099 (Spare)
(50) $\frac{1}{2}$

UHF call sign

STAT

STAT

STEEL BRIDGE 2

Brfg 0755I
T.O. 0955I, 56, 57

land Takhli
5+50 to Takhli
9+30 to Kadema
2 hr on ground
4+00 back to Kadema

ACFT

094

1513

088

099 (Spare)
(50)

UHF call

STAT

SURE HIT

Brfg 0755I
T.O. 1005I, 06
4+00 back to Kadema

ACFT

103

125

099 (Spare)
(50)

UHF call

STAT

TANKER DATA

TOP SECRET

FROM: Mission Coordinator

19 JUNE 1967

SUBJECT: Mission Alert Notification

TO: (See below)

Request your attendance at the Commander's Briefing to be held in the Operations Briefing Room on 19 JUNE 1967 at 1150 L. The briefing concerns the following:

1. Mission Code Name and Number: BX 6705
2. Date/Time of Launch (H-Hour): 20 / 0220 Z / 1120 L.
3. Ground Spare (H+1:00): 20 / 0320 Z / 1220 L.
4. General Area of Operation: N/R.
5. Bases: Takeoff KADENA, Staging -, Landing KADENA.
6. Equipment required: TYPE I, BW, PIN PEG, BIG BLAST, BLUE DOG II, SIP ON SYSTEM 6
7. Ground Spare Requirements: SAME AS PRI. where POSSIBLE.
8. Special Instructions/Comments: LAUNCH BACK UP AT 1220Z IF Pri ABORTS. BX CANCELED MISSION #3

FOR THE COMMANDER

Mission Coordinator

Office	Time (L)	Recipient	Office	Time (L)	Recipient
CMDR	_____	_____	DCOL	_____	_____
DCO	_____	_____	DCOC/MC	<u>0720</u>	<u>2nd</u>
DCM	_____	_____	DCOMI	_____	_____
DCS	_____	_____	DCOW	<u>0735</u>	<u>DW</u>
SECUR	_____	_____	COMMO	_____	_____
FLT SURG	_____	_____	AECS	_____	(Notify Only)
DCCM	_____	_____	TTF (SAC)	_____	(Notify Only)
			REF: F+H RWV		

19/0740I
DWB

20206

18 JUN 67 20 30z

T O P S E C R E T 182014Z CITE ADIC 2783

IMMEDIATE WECEN []

50X1

REALM 232

- A. BX6705
- B. 20/0344Z TO 0626Z JUN 67
- C. COLOR/20/0220Z/0715Z JUNE 67
- D. WITHIN 22595 22520 23030 21030 21095 22595. TGTS: MANY
- E. CANNED RTE NBR 8: A/R'S SURE HIT ARCP 0242Z; STEELE BRIDGE ARCP 0420Z (1ST LOOP) AND 0540Z (2ND LOOP).
- F. TANKER RTES: SEE COLOR 4513. DUE ON STN 1 HR PRIOR ARCP. ETD'S APPROX: KADENA SURE HIT KADENA (ETD 20/0105Z)

KADENA STEELE BRIDGE KADENA/TAKHLI (ETD 19/2255Z)

KADENA STEELE BRIDGE KADENA/TAKHLI (ETD 20/0031Z)

G. TRMLS FOR REALM 236A (FROM WECEN): KADENA, NAHA, BAN TAKHLI, []

50X1

TAOYUAN AND UTAPOA. VLD ENTIRE PRD.

- H. WECEN: REALM-237/IMMEDIATE ADIC, []/FILE NLT 19/1120Z; REALM 233/IMMEDIATE [] INFO ADIC/NLT 19/0420Z; REALM-233AMND/IMMEDIATE [] INFO ADIC/NLT 19/0750Z; REALM-236A/IMMEDIATE [] INFO ADIC NLT 19/0420Z AND REALM-236B/IMMEDIATE [] INFO ADIC/NLT 19/0805Z.

50X1

50X1

50X1

50X1

- I. PLEASE FIVE OUTLOOK FOR FOLLOWING DAY TO APPRISE HQ IF BETTER WEATHER EXPECTED 24 HRS LATER IN NORTH VIETNAM IN THE REALM-233AMND. CONTINUE ALERTS UFN.

50X1

T O P S E C R E T

BT

Handwritten: JPB, 19/0555L, JPY

10 JUN 67 18 39z

20203

T O P S E C R E T 181827Z CITE WECEN 2066

IMMEDIATE ADIC,

REALM 231

A. VALID 0000Z - 0600Z 20 JUN 67

CAT II IN CU CI SE OF 21409 21707 21905 22106 221.0506
22107 22111 22011 21909 21809 21812. EXT NW HANOI BASIN CAT IV
IN ST, BCMB CAT II IN CU AFTER 0400Z.

T O P S E C R E T

BT

QRB 19/0555L
JK

50X1

MISSION: *Blackbird* Mission Coordinator: *W. J. ...*

DCOL CHECK LIST

* DENOTES MANDATORY CALL TO COMMAND POST UPON COMPLETION

H-24:00 TO H-23:30: SECURE SUITS, CHUTES, KITS AND VENT UNITS:
DESIGNATE LIFE SUPPORT TECHNICIANS:

H-23:30: ATTEND COMMANDERS BRIEFING:.....
SUBMIT HANGAR ACCESS ROSTER:.....
ROSTER:.....

H-22:00 TO H-21:30: SELECT O2 (5 CYLINDERS AND 1 LOX CART):.....
Out the Portion
Repositioned { LSD PERSONNEL, ACCOMPANIED BY SECURITY WILL TRANSPORT
O2 TO OPERATIONS.....
COORDINATE WITH INTELLIGENCE AND SURVIVAL PERSONNEL ON
SURVIVAL AND E&E ITEMS:.....

*H-22:00 TO H-17:00: PREFLIGHT:
BOTH SUITS (EA PILOT).....
PARACHUTE AND EMERGENCY O2 SYSTEMS.....
SEAT KIT COMPONENTS.....
SUIT ROOM VENT.....
LOX VENT UNIT.....
OXYGEN CYLINDERS.....
TEST EQUIPMENT.....
TRANSPORT VANS.....

H-20:00: NOTIFY SECURITY, SEAT KIT AVAILABLE FOR PACKING:.....
NOTIFY DCO OF PERSONNEL SELECTED AS RECOVERY TEAM:.....
P.....
S.....

H-14:00: RECEIVE PACKET FROM INTELLIGENCE:.....
H-3:45: RECEIVE PHONE CALL FROM MISSION COORDINATOR:.....
OBTAIN NAMES OF PRIMARY AND SPARE PILOTS AND AIRCRAFT:
P.....
S.....

HELMET, FACEHEAT AND COMMUNICATIONS CHECK AT A/C (ITEM TRANSPORTED TO
HANGAR UNDER SECURITY GUARD).....
INSTALL SEAT KIT AND PARACHUTE:.....
RETURN HELMET TO DCOL:.....

H-3:00 TO H-1:40: PREPARE PREBREATHING ROOM FOR RECEIPT OF PILOT:.....
H-1:45 TO H-1:30: SECURITY INSPECTS SUITS:.....
H-1:40 TO H-1:25: FLIGHT SURGEONS MEDICAL IN DCOL:.....
H-1:20 TO H-1:10: DRESS PILOT:.....
PRESSURE CHECK SUIT:.....

H-1:10 TO H-1:05: PREPARE FOR PILOT TRANSPORT:.....
*H-1:05 TO H-1:00: TRANSPORT TO AIRCRAFT:.....
*H-1:00 TO H-0:45: PILOT HOOKUP AND SUIT A/C CHECK.....
H-0:45 TO TAKEOFF: STANDBY IN DCOL AND PACK LOW RECOVERY EQUIPMENT:.....

LANDING: REMOVE PILOT, TRANSPORT PILOT BACK TO DCOL, DESUIT PILOT:.....
DEBRIEF PILOT, EVALUATE AND CHECK RELIABILITY OF EQUIPMENT:.....
POST-FLIGHT EQUIPMENT:.....

*** TOP SECRET ***

18 Jul 57
1320-1850
*1820-20**
1722 Comp.

PO! 43277

XERO
COPYXERO
COPYXERO
COPYXERO
COPYEQUIPMENT PREFLIGHT FOR HIGH FLIGHTPARACHUTE

1. ✓ Ripcord pins seated (main and first stage).
2. ✓ Pack opening elastics secured.
3. ✓ First stage jettison mated and pins secured.
4. ✓ Two (2) rocket jet units secured.
5. ✓ Manual over ride handle secured.
6. ✓ Green apple secured.
7. ✓ Red knob secured.
8. ✓ Bailout hoses adjusted for pressure suit.
9. ✓ Bailout hose connectors operating.
10. ✓ Harness adjusted for HIGH flight.
11. ✓ Automatic openers - triggered and reset.
12. ✓ Aneroids 1400' to 7500'.
13. ✓ Bailout cylinder pins secured.
14. ✓ Bailout cylinder pressure #1 1800 #2 1800.
15. ✓ Communication cord secured to chute.
16. ✓ Visual inspection completed.

SURVIVAL KIT

1. ✓ Yellow handle secured.
2. ✓ Trigger clearance.
3. ✓ Kit disconnects secured.
4. ✓ Lid secured.
5. ✓ Visual condition.

INSTALLATION

1. ✓ Vent secured at disconnect.
2. ✓ Kit secured to chute - loose.
3. ✓ Emergency oxygen lanyard secured to chute and pin installed.
4. ✓ Communication cord secured at disconnect.
5. ✓ Vent hose secured to chute.
6. ✓ Pin secured in QD and safetied.
7. ✓ Oxygen system low pressure #1 75/70 #2 65/60.
8. ✓ Pip pin in "D" ring.
9. ✓ Stirrup cables extended and operating freely.
10. ✓ Foot rest guards over seat foot rest.

SUBJECT <u>51</u>	AIRCRAFT NUMBER <u>31</u>
TECHNICIAN 	DATE OF FLIGHT <u>20 June 67</u>
SEAT KIT NUMBER <u>51</u>	PARACHUTE NUMBER <u>102</u>
TYPE CUSHION <u>SB</u>	VENT HOSE NUMBER <u>76</u>

Back up (Spare) Pilot

STAT

PRESSURE SUIT HOOK-UP AND CHECKLIST

1. ✓ Packet in pocket.
2. ✓ Stirrups secured.
3. ✓ Communication secured and functioning.
4. ✓ Face heat on (medium).
5. ✓ Oxygen hoses secured in QD.
6. ✓ Three harness snaps secured - harness adjusted and surplus stowed.
7. ✓ Kit adjusted and surplus stowed.
8. ✓ Two (2) bailout hoses secured.
9. ✓ Lap belt, shoulder harness, key secured and adjusted.
10. ✓ Oxygen hoses under right leg strap, chest strap under helmet-hold-down.
11. ✓ Emergency oxygen lanyard secured and pin removed.
12. ✓ Green apple secured.
13. ✓ Red knob secured.
14. ✓ Manual over ride handle secured.
15. ✓ Two (2) rocket jet releases secured.
16. ✓ Check face heat.
17. ✓ Press-to-test both oxygen systems.
18. ✓ LOW oxygen pressure - #1 system 106/100 #2 system 110/100.
19. ✓ HIGH oxygen pressure departing #1 system 8.5 #2 system 8.5.
✓ Readjust lap belt Time 1125
20. ✓ Foot rest guards over seat foot rests.

SUBJECT 51 AIRCRAFT NUMBER 31 STAT

TECHNICIAN DATE OF FLIGHT June 67

HIGH oxygen pressure returning #1 system 7.9 #2 system 8.25.
Time 1245

FULL PRESSURE SUIT TEST LOG

SUBJECT # 1051 FLIGHT DATE 20 June 1967
 SUIT # - 2 LON ~~1110~~ 1110
 OUTER GARMENT W/FLOAT GEAR SEE DOFF 1255
 HELMET # 298 TIME IN SUIT 1:45
 GLOVES # -5 TECHNICIAN
 BOOTS -1

STAT

<u>PRESS-TO-TEST</u>	<u>PRE-FLIGHT</u>	<u>SUBJECT TEST</u>	<u>POST-FLIGHT</u>
<u>SYSTEM #1</u>			
Max Pressure	<u>116</u>	<u>110</u>	<u>116</u>
Differential	<u>1.3</u>	<u>1.4</u>	<u>1.4</u>
Leak Rate	<u>1150</u>	<u>950</u>	<u>1200</u>
<u>SYSTEM #2</u>			
Max Pressure	<u>110</u>	<u>110</u>	<u>110</u>
Differential	<u>1.3</u>	<u>1.5</u>	<u>1.4</u>
Leak Rate	<u>1000</u>	<u>500</u>	<u>800</u>
Unpress Leak Rate	<u>350</u>	<u>700</u>	<u>250</u>
Face Heat	<u>1725</u>		
Commo and Cord	<u>✓</u>		
Pencils	<u>✓</u>		
Knife	<u>✓</u>		
Controller Number	<u>73</u>		
Packet	<u>✓</u>		
Grease Zippers	<u>✓</u>		
Check Location of CO ₂	<u>✓</u>		
Pressure Tap Screws			

FROM:

[Redacted]

19 June 1967

STAT

SUBJECT: Access Roster for Mission BX6705

TO: Mission Coordinator

[Redacted]

<u>C.P.</u>	<u>HANGAR</u>	<u>DCOL</u>
X	X	X
	X	X
	X	X
	X	X
	X	X
	X	X
	X	X

STAT

[Redacted]

STAT

FROM:

[Redacted]

19 June 1967

STAT

SUBJECT: Recovery Personnel for Mission BX6705

TO: DCO

[Redacted]

STAT

[Redacted]

STAT

XERO COPY

XERO COPY

XERO COPY

XERO COPY

TOP SECRET

FROM: Mission Coordinator

19 JUNE 1967

SUBJECT: Mission Alert Notification

TO: (See below)

Request your attendance at the Commander's Briefing to be held in the Operations Briefing Room on 19 JUNE 1967 at 1150 L. The briefing concerns the following:

1. Mission Code Name and Number: BX 6705
2. Date/Time of Launch (H-Hour): 20 / 0220 Z / 1120 L.
3. Ground Spare (H+1:00): 20 / 0320 Z / 1220 L.
4. ~~General Area of Operation~~ N/R
5. Bases: Takeoff KADENA, Staging -, Landing KADENA.
6. Equipment required: TYPE I, BW, PIA PEG, BIG BLAST, BLUE DOG II, SIP ON SYSTEM 6
7. Ground Spare Requirements: SAME AS Pri. where POSSIBLE.
8. Special Instructions/Comments: LAUNCH BACK UP AT 1220h IF Pri ABORTS. BX CANCELED Mission #8

FOR THE COMMANDER

Mission Coordinator

Office	Time (L)	Recipient	Office	Time (L)	Recipient
CMDR	_____	_____	DCOL	<u>0736</u>	<u>R.L.G.</u>
DCO	_____	_____	DCOC/MC	<u>0720</u>	<u>Rnd</u>
DCM	_____	_____	DCCMI	_____	_____
DCS	_____	_____	DCOW	_____	_____
SECUR	_____	_____	COMMO	_____	_____
FLT SURG	_____	_____	AECS	_____	(Notify Only)
DCOM	_____	_____	TTC(SAC)	_____	(Notify Only)

PHYSIOLOGICAL SUPPORT DEBRIEFING

DATE 20 June 7 ACFT 129 PILOT STAT _____
 TIME IN FLIGHT 5730 TIME IN SUIT 7400 PREBREATHING TIME _____

	SATISFACTORY	UNSATISFACTORY																								
1. PHYSICAL CONDITION (PILOT)	<input checked="" type="checkbox"/>	<input type="checkbox"/>																								
2. SURVIVAL KIT AND CUSHION	<input checked="" type="checkbox"/>	<input type="checkbox"/>																								
3. PARACHUTE <u>139</u>	<input checked="" type="checkbox"/>	<input type="checkbox"/>																								
4. HELMET <u>- 2</u>	<input checked="" type="checkbox"/>	<input type="checkbox"/>																								
A. REFLECTIONS	<input type="checkbox"/>	<input checked="" type="checkbox"/>																								
B. FACE HEAT	<input checked="" type="checkbox"/>	<input type="checkbox"/>																								
C. COMMUNICATIONS	<input checked="" type="checkbox"/>	<input type="checkbox"/>																								
5. SUIT PROPER <u>- 4</u>	<input checked="" type="checkbox"/>	<input type="checkbox"/>																								
A. CABIN DECOMPRESSION: YES <u>(NO)</u>	<input type="checkbox"/>	<input type="checkbox"/>																								
6. OUTER GARMENT <u>- 4W</u>	<input checked="" type="checkbox"/>	<input type="checkbox"/>																								
7. BOOTS AND SPURS <u>- 2 00</u>	<input checked="" type="checkbox"/>	<input type="checkbox"/>																								
8. GLOVES <u>- 4</u>	<input checked="" type="checkbox"/>	<input type="checkbox"/>																								
9. OXYGEN SYSTEM	<input checked="" type="checkbox"/>	<input type="checkbox"/>																								
<table border="1" style="width: 100%; border-collapse: collapse; margin-top: 10px;"> <thead> <tr> <th style="width: 5%;"></th> <th style="width: 20%;">DEPART</th> <th style="width: 20%;">RETURN</th> <th style="width: 5%;"></th> <th style="width: 20%;">DEPART</th> <th style="width: 20%;">RETURN</th> </tr> <tr> <th></th> <th>TIME</th> <th>AMT</th> <th></th> <th>TIME</th> <th>AMT</th> </tr> </thead> <tbody> <tr> <td>#1</td> <td><u>1025</u></td> <td><u>8.25</u></td> <td></td> <td><u>1655</u></td> <td><u>7.0</u></td> </tr> <tr> <td>#2</td> <td><u>1025</u></td> <td><u>8.5</u></td> <td></td> <td><u>1655</u></td> <td><u>7.25</u></td> </tr> </tbody> </table>				DEPART	RETURN		DEPART	RETURN		TIME	AMT		TIME	AMT	#1	<u>1025</u>	<u>8.25</u>		<u>1655</u>	<u>7.0</u>	#2	<u>1025</u>	<u>8.5</u>		<u>1655</u>	<u>7.25</u>
	DEPART	RETURN		DEPART	RETURN																					
	TIME	AMT		TIME	AMT																					
#1	<u>1025</u>	<u>8.25</u>		<u>1655</u>	<u>7.0</u>																					
#2	<u>1025</u>	<u>8.5</u>		<u>1655</u>	<u>7.25</u>																					
10. MISCELLANEOUS	<input type="checkbox"/>	<input type="checkbox"/>																								
11. EVALUATION ITEMS	<input type="checkbox"/>	<input type="checkbox"/>																								
A.	<input type="checkbox"/>	<input type="checkbox"/>																								
B.	<input type="checkbox"/>	<input type="checkbox"/>																								
C.	<input type="checkbox"/>	<input type="checkbox"/>																								
D.	<input type="checkbox"/>	<input type="checkbox"/>																								
E.	<input type="checkbox"/>	<input type="checkbox"/>																								
12. REMARKS: (EXPLAIN UNSATISFACTORY REPORT)																										

XERO COPY

XERO COPY

STAT. XERO COPY

EQUIPMENT PREFLIGHT FOR HIGH FLIGHTPARACHUTE

1. ✓ Ripcord pins seated (main and first stage).
2. ✓ Pack opening elastics secured.
3. ✓ First stage jettison mated and pins secured.
4. ✓ Two (2) rocket jet units secured.
5. ✓ Manual over ride handle secured.
6. ✓ Green apple secured.
7. ✓ Red knob secured.
8. ✓ Bailout hoses adjusted for pressure suit.
9. ✓ Bailout hose connectors operating.
10. ✓ Harness adjusted for HIGH flight.
11. ✓ Automatic openers - triggered and reset.
12. ✓ Aneroids 1400' to 7500'.
13. ✓ Bailout cylinder pins secured.
14. ✓ Bailout cylinder pressure #1 1800 #2 1800.
15. ✓ Communication cord secured to chute.
16. ✓ Visual inspection completed.

SURVIVAL KIT

1. ✓ Yellow handle secured.
2. ✓ Trigger clearance.
3. ✓ Kit disconnects secured.
4. ✓ Lid secured.
5. ✓ Visual condition.

INSTALLATION

1. ✓ Vent secured at disconnect.
2. ✓ Kit secured to chute - loose.
3. ✓ Emergency oxygen lanyard secured to chute and pin installed.
4. ✓ Communication cord secured at disconnect.
5. ✓ Vent hose secured to chute.
6. ✓ Pin secured in QD and safetied.
7. ✓ Oxygen system low pressure #1 100/110 #2 90/100.
8. ✓ Pin in "D" ring.
9. ✓ Stirrup cables extended and operating freely.
10. ✓ Foot rest guards over seat foot rest.

SUBJECT <u>50</u>	AIRCRAFT NUMBER <u>29</u>
TECHNICIAN 	DATE OF FLIGHT <u>26 June 67</u>
SEAT KIT NUMBER <u>50</u>	PARACHUTE NUMBER <u>139</u>
TYPE CUSHION <u>5B</u>	VENT HOSE NUMBER <u>71</u>

STAT

PRESSURE SUIT HOOK-UP AND CHECKLIST

1. ~~Packet in pocket.~~
2. ~~Stirrups secured.~~
3. ~~Communication secured and functioning.~~
4. ~~Face heat on (medium).~~
5. ~~Oxygen hoses secured in QD.~~
6. ~~Three harness snaps secured - harness adjusted and surplus stowed.~~
7. ~~Kit adjusted and surplus stowed.~~
8. ~~Two (2) bailout hoses secured.~~
9. ~~Lap belt, shoulder harness, key secured and adjusted.~~
10. ~~Oxygen hoses under right leg strap, chest strap under helmet-hold-down.~~
11. ~~Emergency oxygen lanyard secured and pin removed.~~
12. ~~Green apple secured.~~
13. ~~Red knob secured.~~
14. ~~Manual over ride handle secured.~~
15. ~~Two (2) rocket jet releases secured.~~
16. ~~Check face heat.~~
17. ~~Press-to-test both oxygen systems.~~
18. ✓ LOW oxygen pressure - #1 system 105/110 #2 system 105/110.
19. ✓ HIGH oxygen pressure departing #1 system 8.25 #2 system 8.5.
20. ✓ *Readjust lap belt*
Foot rest guards over seat foot rests.

SUBJECT SD AIRCRAFT NUMBER 29 STAT

TECHNICIAN DATE OF FLIGHT 20 Jan 67

HIGH oxygen pressure returning #1 system 7.0 #2 system 7.25
1655

NOTE

1050

CHANGE ADJ. PARA TO 16" setting

FULL PRESSURE SUIT TEST LOG

SUBJECT # 1050 FLIGHT DATE 20 June 67
 SUIT # -4 DON 1015
 OUTER GARMENT W/FLOAT GEAR -4W DOFF 1715
 HELMET # -2 TIME IN SUIT 7:00
 GLOVES # -4 TECHNICIAN
 BOOTS -2

STAT

<u>PRESS-TO-TEST</u>	<u>PRE-FLIGHT</u>	<u>SUBJECT TEST</u>	<u>POST-FLIGHT</u>
<u>SYSTEM #1</u>			
Max Pressure	<u>112</u>	<u>110</u>	<u>110</u>
Differential	<u>1.4</u>	<u>1.4</u>	<u>1.4</u>
Leak Rate	<u>1300</u>	<u>1100</u>	<u>1350</u>
<u>SYSTEM #2</u>			
Max Pressure	<u>104</u>	<u>110</u>	<u>108</u>
Differential	<u>1.4</u>	<u>1.4</u>	<u>1.4</u>
Leak Rate	<u>1000</u>	<u>1250</u>	<u>1250</u>
Unpress Leak Rate	<u>450</u>	<u>500</u>	<u>550</u>
Face Heat	<u>180ms</u>		
Commo and Cord	<u>ok</u>		
Pencils	<u>✓</u>		
Knife	<u>✓</u>		
Controller Number	<u>71</u>		
Packet	<u>✓</u>		
Grease Zippers	<u>✓</u>		
Check Location of CO ₂	<u>ok</u>		
Pressure Tap Screws		<u>✓</u>	

XERO
COPYXERO
COPYXERO
COPY

Mission No. _____

Date _____

INTELLIGENCE CHECKLIST

	<u>H-Hour</u>	<u>Time (L)</u>	<u>Action Completed</u>	<u>Remarks</u>
Receive Mission, Alert Notification	-2400	1120	0600	
Attend Commander's Briefing	-2330	1150	1150	
Update Intelligence Review Briefing	-2230	1250	1250	
Coordinate with DCOL on E&E Kit Items	-2200	1320	1300	
*Coordinate with DCOMM on SAM site plotting	-2000	1540	1300	
*Insure Realm 77 rechecked. Complete Sam plotting	-1800	1720	0600	
Present Intelligence Review Briefing (In vault)	-1800	1820	1720	
Present Recap of Briefing (Briefing Room)	-1700	1820	1820	
Prepare E&E Kits	-1630	1930	1650	
Issue E&E Kits to DCOL	-1400	2120	1715	
Present Last Minute Intelligence	-330	0150	0150	
Debrief	+ 45			
*Prepare Para C Realm 118 and turn in to DCO	+ 130			
*Store Mission Material	+2100			
* Coordinate with Command Post				

XERO COPY XERO COPY XERO COPY

TOP SECRET

20 June 67

DEBRIEFING REALM 118
(INTELL)

- A. MISSION NO. BX 6705
- B. TITLE OF MESSAGE. REALM 118 "PART C"
- C. SIGNIFICANT OBSERVATIONS AND LOCATION: (INCLUDE EVIDENCE OF ANY INTERCEPT ATTEMPT, AA OR ANY OTHER PERTINENT INFORMATION)

Smoke cloud observed AT
2126N 10505E, possibly oil storage
TANKS.

Smoke Clouds observed AT approx 1710N
10637E clouds were within a 5 mile
radius, possibly oil storage Tanks..

Fighter active picked up on radio ^{JHF} between
2037N - 10640E and 2155N 10520E (dog fighting)

Pingpong red light active at approx
1402N 10937E light on for approx 30 Sec.
second time Jam area radio was jammed light
went out.

TOP SECRET.

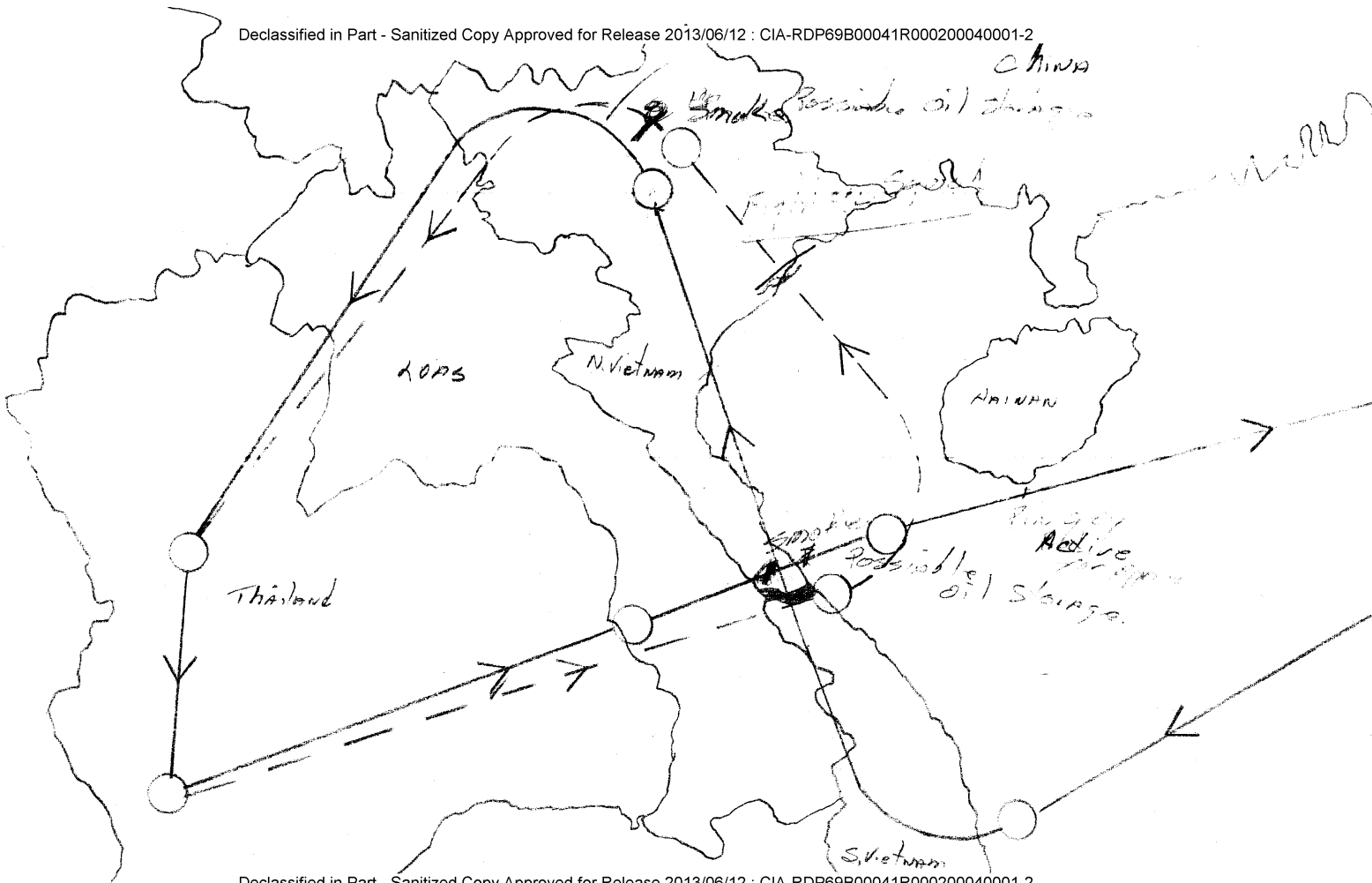

Bx 6705

Kit # 2

Dayton
Name of Individual

19 June 67
Date

Braclet Gold 1 Ea ✓

Watch SN 1 Ea ✓

Ring Gold 2 Ea ✓

Money SN None

Blood Chit 300 ✓

Cloth Charts 406/407 ✓

Prepared by DCOMI (Time) 1650

Inspected & Sealed by Security (Time) 1715

Received by DCOL (Time) 1718

STAT

STAT

STAT

STAT

BX 6705 Backup

3

Vojvodic b
Name of Individual

19 June 67
Date

Braclet Gold 1 Ea ✓

Watch SN 1 Ea ✓

Ring Gold 2 Ea ✓

Money SN None.

Blood Chit 300 ✓

Cloth Charts 406/407 ✓

Prepared by DCOMI (Time)

1653

Inspected & Sealed by Security (Time)

1715

Received by DCOL (Time)

1718

Returned 1400 20 June 67

STAT

STAT

STAT

STAT

GENTLEMAN!

YOU HAVE ALREADY RECEIVED YOUR
INTELLIGENCE BRIEFING ON ENEMY DEFENSES
FOR THIS MISSION, ~~AND~~ YOU WERE ^{ALSO} GIVEN EYE
INFORMATION PERTAINING TO THE COUNTRIES
THAT YOU WILL OVERFLY.

~~YOU HAVE BEEN~~
POLICY & PROCEDURES FOR DOWNED
PILOTS HAS BEEN DISCUSSED WITH YOU

GENTLEMAN - DO YOU HAVE ANY QUESTIONS
THAT I MIGHT ANSWER AT THIS TIME
CONCERNING THE ABOVE SUBJECTS.

THANK YOU

TOP SECRET

FROM: Mission Coordinator

19 JUNE 1967

SUBJECT: Mission Alert Notification

TO: (See below)

Request your attendance at the Commander's Briefing to be held in the Operations Briefing Room on 19 JUNE 1967 at 1150 L. The briefing concerns the following:

1. Mission Code Name and Number: BX 6705
2. Date/Time of Launch (H-Hour): 20 / 0220 Z / 1120 L.
3. Ground Spare (H+1:00): 20 / 0320 Z / 1220 L.
- ~~4. General Area of Operation~~ N/R
5. Bases: Takeoff KADENA, Staging -, Landing KADENA.
6. Equipment required: TYPE I, BWI, PIR PEG, BIG BLAST, BLUE DOG II, SIP ON SYSTEM 6
7. Ground Spare Requirements: SAME AS Pri. where POSSIBLE.
8. Special Instructions/Comments: LAUNCH BACK UP AT 1220Z IF Pri ABOYTS. BY CANCELED Mission # 8

FOR THE COMMANDER

Mission Coordinator

<u>Office</u>	<u>Time (L)</u>	<u>Recipient</u>	<u>Office</u>	<u>Time (L)</u>	<u>Recipient</u>
CMDR	_____	_____	DCOL	_____	_____
DCO	_____	_____	DCOC/MC	<u>0720</u>	<u>2nd</u>
DCM	_____	_____	DCOMI	_____	_____
DCS	_____	_____	DCOW	_____	_____
SECUR	_____	_____	COMMO	_____	_____
FLT SURG	_____	_____	AECS	_____	(Notify Only)
DCOM	_____	_____	TTFC(SAC)	_____	(Notify Only)

MESSAGE TRAFFIC LOG

MSG #	REALM #	TIME RECD	CITE	ACTION	REMARKS
1	232	18/2035Z	ADIC 2783	DCO/WX	
2	72T	2055Z	ADIC 2786	SAC	
3	54	2055Z	ADIC 2784	MIC FP	
4	231	18/1900Z	WECEN 2066	WX	
5	77	18/2120	ADIC 2791	INTC/DCO	
6	71	18/2130	ADIC 2795	FP DCO	
7	62	18/2130	ADIC 2790	Commnd/FP/SAC	
8	—	18/2240		MIC Commnd	STAT
9	79T	18/2253	ADIC 2796	SAC MIC	
10	79T	18/2259	ADIC 2798	" "	
11	79T	18/2259	ADIC 2797	" "	
12	78	19/0050Z	ADIC 2801	FP/MC	
13	63	19/0050Z	ADIC 2801	FP/MC/DCM	
14	236A	19/0446	WECEN 2073	WX/MC	
15	233	19/0446	WECEN 2072	WX/MC	
16	GREY STAR	19/0617	31314	MIC + WX	
17	233AD	19/0756	WECEN 2075	WX/MC	
18	236B	19/0756	WECEN 2075	WX/MC	
19	237	19/1042	" 2074	WX/SAC	
20	234	19/1251	ADIC 2803	WX	
21	235	19/1620	"	WX	
22	—	19/1515		DCO/SEC	STAT
23	X	19/1641	ADIC 2821	DCO/SEC	
24	313 th	19/1825	DOS M00092	DCO	
25	231	19/1851	WECEN 2090	WX	
26	95T	19/1915	ADIC 2843	SAC	
27	235 AM	19/2147	WECEN 2093	WX	
28	X	19/2319	ADIC 2812	DCM	
29	90	20/0031	ADIC 2804	DCO	
30	700	20/0033	WECEN 2074	WX	

MESSAGE TRAFFIC LOG

MSG #	REALM #	TIME RECD	SITE	ACTION	REMARKS	
31	240	20/0029	WECEN 2044	WX		
32	240	20/0053	" 2048	WX		
33	24	20/0201	WECEN 2099	WX		
34	X	20/0314		SAC		STAT
35	240	20/0351	WECEN 2102	WX		
36	X	20/0507		SAC		STAT
37	240	20/0510	WECEN-2104	WX		
38	X	20/0840		SAC		STAT
39	X	20/0711		SAC		
40	130	20/1102	ADIC 2003	M/C		
41	121	20/2055		Dcom		STAT
42	119	21/0934		SEC		
43	120	21/1240		FP		
44	121	21/1643		FP	CORRECTED COPY	
45	122	21/1837		FP		
46	X	21/1907	ADIC 3051	FP		
47	X	22/1507	" 3113	Sec		
48	129	26/2348		INS		STAT

NNNNZCZC477FTP583/252325Z ZFO [redacted]

50X1

BT

XXXXX

OPCEN 783 [redacted]

50X1

OPCEN PASS [redacted]

T O P S E C R E T 262328Z CITE [redacted]

50X1

PRIORITY ADIC, [redacted]

26 JUL 67 23 41

50X1

REALM 129

A. BX6705

B. INS-FILM CORRELATION REPORT

C. INS 010

D.

1. 11 QUESTIONABLE FRAMES, OTHER WERE SATISFACTORY

2. SATISFACTORY

3. SATISFACTORY

4. INS TAPE 0.0005 RADIANS/SECOND LOWER THAN VALUES RECORDED FROM FILM THROUGHOUT MOST OF MISSION.

5. SATISFACTORY

6. SATISFACTORY

7. SATISFACTORY

8. SATISFACTORY

9. SATISFACTORY

10. CLOCK 2 SECONDS HIGH AT BEGINNING OF MISSION. GRADUAL DRIFT TO 4 SECONDS AT END OF MISSION.

E. ERRORS IN CAGING RECORD OCCURRED DURING PERIODS OF CAGING.

6 INS DATA LINES MISSING BETWEEN ELAPSED TIMES 11409 AND 11414.

267 INS DATA LINES MISSING BETWEEN ELAPSED TIMES 11450 AND 11451.

17 INS DATA LINES MISSING AT END OF MISSION FOLLOWING ELAPSED TIME 17879.

MISSING INS DATA LINES CAUSED DIFFICULTY IN CORRELATION.

CORRELATION WAS ACCOMPLISHED BY MANUAL HEADING OF DATA BLANKS ON PHOTOGRAPHIC FRAMES CORRESPONDING TO MISSING DATA LINES.

T O P S E C R E T

BT

48

UZCZC290

222/221454Z

BT

XXXXX



50X1

221007 15 11z

201111

TOP SECRET 221451Z CITE ADIC 1113

PRIORITY

50X1

REALM-X

REF:

(REALM 119 -EX6705)

50X1

1. PER REF MSG PARA D SHOULD GIVE OPERATIONAL MISSIONS ATA IN ZULU AND STATION.
2. PARA E SHOULD READ ATDCIN ZULU AND STATION, REPEAT ATD (IN ZULU) AND STATION.
3. PARA F SHOULD INCLUDE REMAINING ITINERARY, ETD'S AND ETA'S OF COMMERCIAL AIR FLIGHT OR PILOT'S NAME AND AIRCRAFT CALL SIGN IF MILITARY AIRCRAFT. ETA OF ZI FINAL ARRIVAL POINT SHOULD BE INCLUDED IN THIS PARAGRAPH. PLEASE USE ZULU TIMES.
4. PLEASE DELETE BAIL AS AN ADDRESSEE OF THE REALM-119 REPORT.

TOP SECRET

BT

*original DCO
CC + Security*

RG

47

ILLEGIB

Declassified in Part - Sanitized Copy Approved for Release 2013/06/12 : CIA-RDP69B00041R000200040001-2

Page Denied

Next 2 Page(s) In Document Denied

Declassified in Part - Sanitized Copy Approved for Release 2013/06/12 : CIA-RDP69B00041R000200040001-2

NNNN

0ZCZC213

[redacted] 211233Z ZFF-3 ZPO [redacted]

50X1

BT

50X1

XXXXX

OPCEN 779 [redacted]

50X1

OPCEN PASS [redacted]

TOP SECRET 211229Z CITE [redacted]

50X1

IMMEDIATE ADIC, [redacted] INFO IMMEDIATE [redacted]

50X1

OXCAR/BLACK SHIELD

50X1

REALM-120

A. BX6705

B. FLASH PROCESSING REPORT

C. TYPE I

D. 1G

E. COMMENTS: THE FILM QUALITY AND IMAGE QUALITY ARE GOOD. THE IMAGERY IS UNDEREXPOSED AT THE START OF THE MISSION, ESPECIALLY ON THE AFT CAMERA, HOWEVER NO HEAVY IMAGE DEGRADATION IS APPARANT. APPROX. 20 PERCENT OF MISSION IS CLOUD COVERED. VETERING IS MORE ERRATIC THAN ON PREVIOUS MISSIONS.

TOP SECRET

BT

43

2018012 744-3 2 PD

Declassified in Part - Sanitized Copy Approved for Release 2013/06/12 : CIA-RDP69B00041R000200040001-2

50X1

BT

50X1

XXXXX

50X1

OPCEN 778

[Redacted]

OPCEN PASS

2 1 1 7 3 2

20053

T O P S E C R E T 210820Z CITE

50X1

IMMEDIATE ADIC INFO IMMEDIATE

[Redacted]

REALM-119

A. BX6705

B. TAXE PROGRESS REPORT

C. [Redacted]

50X1

D. ARRIVED [Redacted] 21/0735Z.

50X1

E. N/A

F. N/A

G. NONE

H. N/A

I. [Redacted] WILL CONTINUE ON TO WASH DC WITH MATERIAL FOR

50X1

PROJECT HDQS VIA UAL 681. ETA WASH DC 21/1329 LOCAL. BLUE DIF

WILL BE REMOVED FROM PACKAGE AND WILL BE COLFERIED TO [Redacted]

50X1

[Redacted] VIA AAL 335/215. [Redacted] SAN FRANCISCO 21/2151 LOCAL.

50X1

T O P S E C R E T

BT

42

TOP SECRET 200352 CITE [REDACTED]

50X1

IMMEDIATE ADIC, [REDACTED]

50X1

REALM 121

2 13 11 10 15z

A. BX6705

B. INS TAPE EVALUATION REPORT

C. INS 010

D. 20/0931 Z

E. 1. SATISFACTORY

2. SATISFACTORY

3. SATISFACTORY

4. SATISFACTORY

5. LEAST SIGNIFICANT DIGIT MESSIION AT ELAPSED TIMES

17326 AND 17394

6. SATISFACTORY

7. SATISFACTORY

8. SATISFACTORY

9. SATISFACTORY

12. SATISFACTORY

F. EXTRA DATA LINE BETWEEN ELAPSED TIMES, 11062 AND 11058.

SIX DATA LINES MISSION BETWEEN ELAPSED TIMES 11429 AND 11441.

ONE GARBLED DATA LINE BETWEEN ELAPSED TIMES 11375 AND 11398.

EVALUATION PERTAINS TO CAMERA TAPE REELS ONLY. TAPE REELS ABOVE CAN

BE SALVAGED.

TOP SECRET

BT

41

ZCZC128

410/201107Z ZFF-3 ZPO



50X1

BT

XXXXX



50X1

20 Jun 67 11 10z

201395

T O P S E C R E T 201057Z CITE ADIC 2905

50X1

IMMEDIATE INFO PRIORITY

50X1

REALM 130

A. BX6705

B. SUPPORT TERMINATION MSG

C. SUPPORT REQUIREMENT FOR ABOVE MISSION TERMINATED

D. NONE

T O P S E C R E T

BT



Page Denied

Next 2 Page(s) In Document Denied

ZCZC100FTX183/*****/200515Z ZFF- [redacted]

50X1

BT

KXXXX

OPCEN 010 [redacted]

50X1

T O P S E C R E T 200515Z CITE WECIN [redacted]

20288

JJJJJSSSSFLASH ADIC, [redacted]

50X1

REALM-240

A. [redacted]

50X1

1111

T O P S E C R E T

BT

A

37

Am

38

NNN
N

NNNNZCZC099TSCN301FTM230/200455Z ITC [REDACTED] - 1 OPCEN

50X1

BT

XXXXX

OPCEN 954 [REDACTED]

50X1

SECRET 200448Z CITE [REDACTED]

50X1

*****FLASH ADIC, [REDACTED]

50X1

THIS IS A BLACK SHIELD MESSAGE, [REDACTED].

RECEIVED FROM [REDACTED]

50X1

KOLL TRANSMISSION 5038

REPEAT 5038

SECRET

BT

Page

A

36

NNNNZCZC091FTX180****/200349Z ZFF 1 2 0

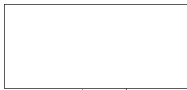

50X1

BT

XXXXX

OPCEN 010



50X1

2013-1

20 Jun 7

TOP SECRET 200348Z CITE VECEN 112

FLASH ADIC,



50X1

REALM 240

A.



50X1

B. 1311

TOP SECRET

BT

A

Handwritten signature

35

NNNN

UNSMC090

TSCN375FTH228/208310Z ***** EYE 211-5 210 OPCEN

[Redacted]

50X1

BT

2013

XXXXX

OPCEN 953

[Redacted]

50X1

OPCEN PASS

[Redacted]

50X1

SECRET 200308Z CITE

[Redacted]

BT

50X1

FLASH ADIC

[Redacted]

50X1

THIS IS A BLACK SHIELD MESSAGE, REALITY

RECEIVED FROM

[Redacted]

50X1

FOLL TRANMISSION 5053

REPEAT 5053

SECRET

BT

Handwritten signatures and a circled number '34'.

NNNN YZCZC055FTX176*****Z010155Z 11 17



50X1

BT

XXXXX

OPCEN 008

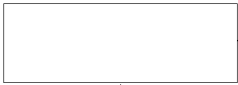

50X1

2013

TOP SECRET 200158Z QITE VECI 11 17

FLASH ADIC,



50X1

REALM 240

A.



50X1

B. 1511

TOP SECRET

BT

Handwritten signature

33 (circled)

Handwritten mark

NYNOM

ZCZC079FTX174'****/200015Z ZTF1 ZP



50X1

BT

XXXXX

OPCEN 007



50X1

20276

TOP SECRET 200050Z CITE WECEN 1998

FLASH ADIC,



50X1

REALM 240

A.



50X1

B. 6111

TOP SECRET

BT

33

A

Handwritten signature

32

NYNOM

ZCZCB76FTX173/*****/200036Z Z F I



50X1

BT

XXXXX

OPCEN 006



50X1

T O P S E C R E T 200035Z CITE WECIN

FLASH ADIC,



50X1

REALM 240

A.



50X1

B. 6512

T O P S E C R E T

BT

Handwritten signatures and a circled number '31'.

ZC2C075FTX172***** / 2002342 2FFA



50X1

BT

XXXXX

OPCEN 005



50X1

2002

TOP SECRET 2002532 CITE REFERENCE 1990

FLASH ADIC



50X1

REALM 240

A.



50X1

B. (111)

A.



50X1

B. 1513

TOP SECRET

BT

Handwritten: 30 p/r A

SECRET

NNNNZCZC074

370/200033Z ZFF-1 ZPO

50X1

BT

XXXXX

50X1

TOP SECRET 200031Z CITE ADIC

20 JUN 67 00 35z

FLASH INFO PRIORITY

50X11

REALM 90

20269

- A. BX6705
- B. MISSION GO-NO-GO MSG
- C. APPROVED
- D. NONE

TOP SECRET

BT

Handwritten: 29 (circled), N/A, B

NNNN

NNNNOFKHCZCZC065

35 6/192304Z

BT

XXXXX



50X1

SECRET 192304Z CIVE ADXC 2581

PRIORITY



50X1

REALM X (BX5705)

REF: [Redacted] (REALM 35)

50X1

1. REQUEST CONFIRMATION OF ACFT IN CONTAINED IN REF.
2. REALM 87'S DO NOT SHOW A INT OF WITH TAIL NHR

522 PARTICIPATING IN BX5705.

SECRET

BT

My
WA
(28)

20260

19 JUN 67 21 47z

T O P S E C R E T 192141Z CITE WECEN 2093

IMMEDIATE ADIC,

50X1

REALM 235 (AMD)

- A. BX6705
- B. 20/0344Z TO 0626Z JUN 67
- C. NO SIG CHG. POSSIBLE BETTER THAN BRIEF IN MTNS NE NVN.
- D. NO CHG
- E. NO CHG
- F. N/A

T O P S E C R E T

BT

MW 27 *A*
W

TOP SECRET 191909Z CITE ADIC 2840

IMMEDIATE INFO PRIORITY

REALM 95T

- A. BX6705
- B. TANKER MISSION SUPPORT EXECUTION 18K
- C. APPROVED
- D. NONE

TOP SECRET

BT

550X1

[Handwritten signature]
[Handwritten number] 26

XXXX

OPCEN 003



50X1

TOP SECRET 191843Z CITE WECEN 1100

IMMEDIATE ADIC,



50X1

REALM 231

A. VALID 0000Z-0600Z 21 JUN 67

B. CAT II IN CU AC CI SO EAST OF 22215 22112 22100 22206 22105 215 05.0
21608 21409 21209 21010, EXCEPT FOR 60 TIP RAINIER ISLAND IN CAL IV
AND CAT II AND III EAST OF 1138. RMB CAT IV AND V.

TOP SECRET

BT

Handwritten: M Nye 10
25-10

Page Denied

Declassified in Part - Sanitized Copy Approved for Release 2013/06/12 : CIA-RDP69B00041R000200040001-2

~~TOP SECRET~~

T O P S E C R E T 191622Z CITE ADIC 2821

PRIORITY

[Redacted]

19 JUN 67 16 41z

50X1

REALM X (BX6705)

REF:

[Redacted]

50X1

PLS IMPLEMENT.

T O P S E C R E T

BT

[Handwritten signature]
[Handwritten 'A']
[Handwritten '23']

Declassified in Part - Sanitized Copy Approved for Release 2013/06/12 : CIA-RDP69B00041R000200040001-2

50X1

20234

TOP SECRET 191505Z CITE [redacted]

50X1

IMMEDIATE ADIC INFO IMMEDIATE [redacted]

50X1

OX CART BLACK SHIELD BX6705 OPS

REF: A. ADIC 2793

B. [redacted]

50X1

A REGULAR C-141 FLIGHT 0420 IS SCHEDULED TO DEPART KADENA 20 1400Z FOR DOVER WITH ONE ENROUTE STOP AT ANCHORAGE. ACFT DIRECTED TO LAND

[redacted] - ETA 21 0830Z. TO ONLOAD TAKE AND COURIER KADENA MY

50X1

REF B APPLIES.

TOP SECRET

BT

[Handwritten signature]
[Handwritten initials]
22

20235

T O P S E C R E T 191607Z CITE WECEN 2088

IMMEDIATE ADIC,

REALM 235

19 JUN 67 16 20z

50X1

A. BX6705

B. 20/0344Z TO 0626Z JUNE 67.

C. NO SIG CHG, EXCPT CAT II IN CU CI EAST OF MTN RIDGE FROM 20N TO 15N.

D. BRKN CI 250/350 TO 20N WITH ISLTD CB TOPS TO 400; BRKN CI 250/350 19N; CAT II IN CU AND CI TO MTN RIDGE SVN. NO SIG CHG ON RETURN.

E. SURE HIT: 6/8 CI CS 280/350, 2-4 MI, 270/15M31, ISLD CB TO 400 NORTH OF A/R, 380/660.

STEEL BRIDGE: 4/8 CI 300/350, 7 MI, 090/10M31, ISLD CB TO 350 WEST OF A/R, 370/670.

F. 417 DATA AVAILABLE FOR PHONE DISCUSSION AT APROX 0140Z AS PER TELE

T O P S E C R E T

BT

A

Not
21

50X1

ZCZC 024

191/191243Z ZFF1

BT

XXXXX

[Redacted]

WECEN 536

50X1

20032

TOP SECRET 191257Z CITE ADIC 800

IMMEDIATE [Redacted] WECEN

50X1

REALM-234

A. BX6705

B. 20/2344Z TO 0526Z JUNE 67

C. THRU E. NO CHANGE FROM REALM-234 (AMND NBR 6)

F. [Redacted] ADD UTAPDA ON REALM-235 AND 3.

50X1

G. WECEN: REALM-235/IMMEDIATE [Redacted] ADIC/NLT 19/1620Z; REALM-234

50X1

AMND/ IMMEDIATE [Redacted] ADIC/NLT 19/1620Z.

50X1

H. NOTE: [Redacted] AND WECEN: AMND NBR 7 TO REFLECT REALM-234 DUE ADD E

50X1

TIME TO 1330Z. THIS TIMING NECESSARY SINCE NO BRIEFING IS

HELD AT 1200Z, REGARDLESS OF ETD OF 191.

TOP SECRET

BT

None
20
#9

Page Denied

NNNNZCZC 2070X 137/1907137 ZRF-S ZPD [redacted]

BT

XXXXX

[redacted] OPCEN 995

20218

T O P S E C R E T 190735Z CITE WECEN 2071

IMMEDIATE [redacted] INFO IMMEDIATE ADIC

REALM-236B

A. RX 6705

B. 20/0344Z TO 0626Z JUNE 67

C. KADENA-NAHA: 2-4/B CU 25/100 4/100 12B/150

6/8 CI-CS 230/LYRD/350, 1, 230/15620, 1, 150, ISLT CB/RW

VCNTY, 380/660

BAN TAKHLI-NO SIG CHG

[redacted] NO SIG CHG

TAO YUAN: ADD 5/8 CI 280/350 985T

U TAPAO: NO SIG CHG

T O P S E C R E T

BT

50X1

50X1

50X1

50X1

[Handwritten signatures and scribbles]

FIVEP

KRRZCZC006FTX136/190735Z ZFF-3 ZP3 [REDACTED]

BT

XXXXX

[REDACTED] OPCEN 994

50X1

50X1

2 JUN 67 07 41z

20227

T O P S E C R E T 190735Z CITE WECEN

IMMEDIATE [REDACTED] INFO IMMEDIATE ADIC

50X1

REALM-233 AFD

A. BX6705

B. 20/0344Z TO 0625Z JUN 57

C. CAT THREE IN CU-AG-CI SOUTHEAST

22229 221.5/87 22205 220/05.5 21806 20 01 21 7/08.5 21209

21011 CAT TWO IN CU-CI WITHIN 220/00 2 22110 221.5/88 221.7/85

220/05.6 21906 215.7/89 21909 220/00 2 BYR SAME

D. A/R FCETS SURE HIT: 5/8 CI-CS 2 1/85 2-4, REST SAME

STEEL BRIDGE NBR 1 AND 2: NO SIG CHG

E. OUTLOOK FOR FOLLOWING 24 HRS: 11 P 1 110 CIG, CLD

COVER IS EXPECTED TO REMAIN FKN THIN 1 111 1-2/85 LOW

CLD. BASIN WILL REMAIN CAT TWO WITH 110 THREE IN SURROUNDING

MIS.

T O P S E C R E T

BT

Wm

Wm

Page Denied

NNNN

ZCZC998FTX128

/190431Z ZFF3 ZPO

50X1

BT

XXXXX

OPCEN 992

50X1

TOP SECRET 190429Z CITE WECEN 19178

IMMEDIATE INFO IMMEDIATE ADIC

20314

50X1

REALM-233

A. BX6705

B. 20/0344Z TO 0626Z JUN 67.

C. CAT II-III IN CU-9C, CI SOUTH OF 21309 21002 220.5/10.3
221.5/08.5 22107 221.5/05.8 220/05.7 21006 215/08.6 CAT FOUR IN
ST BONG CAT TWO-THREE IN CU BY 2400-0122 SOUTH OF 2213/06.2 21206
221.705 220/05.6 CAT THREE CU-AC-CI 50 NORTHEAST OF 21020 21525 21030
RMDR CAT FOUR-FIVE.

D. A/R FORECASTS: SURE HIT 5/3 CI-9C 2102/110/400, 2-4, 31/204,
ISLD CB TO 400, 380/660.

NBR 1 STEEL BRIDGE 6/8 CI 300/110.7, 140/10, CB TO 450,
370/670

NBR 2 STEEL BRIDGE NO SIG CEN FROM NBR 1.

E. CAT TWO IN HANOI BASIN PREDICTED FROM CAMERA SEEING THIN CI IN
CI, SFC DATA INDICATES 1-5/3 COMBINED LOW, MIDDLE OLD AND 5-7/3
THIN CI. 417 INFO SHOWS CI IS VERY THIN.

TOP SECRET

BT

Handwritten signatures and initials: "Ruse W" and a large circle.

NNNNZCZC999FTX 129

/190438Z ZFF3 ZPO [redacted]

50X1

BT

XXXXX

[redacted] OPCEN 993

50X1

20202

T O P S E C R E T 190438Z CITE WEGEN [redacted]

IMMEDIATE [redacted] INFO IMMEDIATE ADIC

50X1

REALM-236A

A. BX6705

B. 20/0344Z TO 0626Z JUN 67.

KADENA: 2-4/8 CU 25/100 4/8 AC 12/150 6/8 CI-CS 230/L 10/

400, 7, 230/15G20, FL160, ISLD CB/RW VCNTY, 380/560.

NAHA: SAME AS KADENA.

BAN TAKHLI: 3/8 CU-SC 20/100 2/8 AC 12/150 6/8 CI 300/350,

5H-7, 200/10, FL160, CB/RW VCNTY, 370/570.

50X1

TAO YUAN: 2/8 CU 25/60 6/8 AC 100/120 7/7/05, FL150, 33/40/1.

U TAPAO: 3/8 CU 20/80 2/8 AC 100/150 6/8 CI 300/350, 5H-7,

210/10, FL160, RW VCNTY, 370/570.

T O P S E C R E T

BT

Handwritten signatures and initials

Page Denied

Next 2 Page(s) In Document Denied

NNNNERZCZC986

162/190015Z ZFF-1

BT

XXXXX



50X1

20219

T O P S E C R E T 190012Z CITE ADIC 2802

IMMEDIATE



19 JUN 67 00 36z

50X1

REALM 78

A. BSX6705

B. MISSION PLAN MESSAGE (THREE)

C. STANDBY 2 PC01/000

ON PC04/000

STANDBY 2 PE01/000

ON PI01/305

STANDBY 2 QD01/000

ON QH01/303

STANDBY 2 RC02/210

D. AD01/000 AND PE01/000

PI01/000 AND QD01/000

QH01/000 AND RE01/000

E. PC04/090 AND PD02/000

QA01/067 AND QB01/000

QB02/068 AND QC01/000

RB02/058 AND RB02/148

F. PSR: N/A

G. SESR: N/A

SEPNR: N/A

SEPC: N/A

SESC: N/A

H. PRIMARY ACFT

BACKUP ACFT

20/0242Z

20/0342Z

20/0420Z

20/0520Z

20/0542Z

20/0642Z

I. 75M/3.1

NONE

[Handwritten signature]

[Handwritten mark]

[Handwritten circled number 12]

[Handwritten signature]

SECRET

NNNNZCZC979

157/182250Z ZFF1 ZPO

50X1

BT

XXXXX

50X1

20218

T O P S E C R E T 182244Z CITE ADIC 2797

IMMEDIATE

INFO PRIORITY

50X11

REALM 79T

A. BSX6705

B. TANKER MISSION PLAN MESSAGE (A/R ONE)

C. STEEL BRIDGE, ARCP 17-00N; 099-40E. END A/R: 14-15N; 099-40E

D. PRIMARY 20/0420Z; BACKUP 20/0520Z

E. 69810

F. 208

G. 069

H. INITIAL REPORT UPON ARRIVAL AT ARCP, SUBSEQUENT REPORTS ONLY
IF WEATHER CHANGES.

I. NONE

T O P S E C R E T

BT

18 JUN 67 22 59Z

NNNNZCZC980

158/182248Z ZPO ZFF-1

50X1

BT

XXXXX

20217

50X1

T O P S E C R E T 182245Z CITE ADIC 2798

IMMEDIATE INFO PRIORITY

50X1

REALM 79T

18 JUN 67 22 58Z

50X1

- A. BSX6705
- B. TANKER MISSION PLAN MESSAGE (A/R TWO)
- C. STEEL BRIDGE. ARCP: 17-00N; 099-40E. END A/R 14-15N; 099-40E
- D. PRIMARY 20/0542Z; BACKUP 20/0642Z
- E. 58,731
- F. 213
- G. 180
- H. INITIAL REPORT UPON ARRIVAL AT ARCP, SUBSEQUENT REPORTS ONLY IF WEATHER CHANGES.
- I. NONE

10
Mr
Noye

T O P S E C R E T

BT

NNNNZCZC977

156/182245Z ZPO ZFF-1

BT

XXXXX

50X1

20216

50X1

18 JUN 67 22 53z

T O P S E C R E T 182242Z CITE ADIC 2796

IMMEDIATE INFO PRIORITY

REALM 79T

50X1

- A. BSX6705
- B. TANKER MISSION PLAN MESSAGE (TOPOFF)
- C. SURE HIT, ARCP: 24-19N; 125-58E. END AR: 22-40N; 124-30
- D. PRIMARY 20/0242Z; BACKUP 20/0342Z
- E. 43,732
- F. 218
- G. 237
- H. INITIAL REPORT UPON ARRIVAL AT ARCP, SUBSEQUENT REPORTS ONLY IF WEATHER CHANGES.
- I. NONE

T O P S E C R E T

BT

W

NYT *9* *H*

975

TSCN314FTH201/182210Z ZFF-1 ZPO OPCEN [redacted] WECEN

50X1

BT

XXXXX

OPCEN 950 [redacted] WECEN 058

50X1

T O P S E C R E T 182208Z CITE [redacted]
IMMEDIATE ADIC, [redacted] WECEN

50X1

50X1

OXCART/PINWHEEL

20215

BX 6705

THIS IS A BLACK SHIELD MESSAGE.

1. TANKER/WX SCOUT RECALL WORD IS

[redacted]

50X1

2. IF THIS RECALL WORD IS USED, [redacted] WILL ISSUE A NEW RECALL
WORD WITH AN EFFECTIVE TIME.

50X1

T O P S E C R E T

BT

18 JUN 67 22 33z

Handwritten signatures and initials

Page Denied

20212

T O P S E C R E T 182110Z CITE ADIC 2795

IMMEDIATE INFO PRIORITY

REALM 71

18 JUN 67 21 24z

50X1

A. BSX6705

B. MISSION PLAN MESSAGE (ONE)

C. BLACK SHIELD CANNED ROUTE EIGHT, SURE HIT DEPARTURE (TOPOFF),
STEEL BRIDGE WITHDRAWAL (A/R ONE), STEEL BRIDGE RECOVERY (A/R
TWO).

D. NONE

E. NONE

T O P S E C R E T

BT

Handwritten: (6) N myc H

20210

T O P S E C R E T 182046Z CITE ADIC 2791

IMMEDIATE

50X1

REALM 77

A. BX6705

B. CURRENT INTEL MESSAGE

C. 18 JUN 1967

D. ADIC 1171

E. ADIC 1171. APPARENTLY NEITHER BSX001 NOR BSX003 WERE DETECTED BY NVN OR CHICOM RADAR.

F. ORDER OF BATTLE:

(1) AIRCRAFT:

13 MIG-21

PHUC YEN A/F, NORTH VIETNAM.

25 MIG-19

HAIKOU A/F, HAINAN ISLAND, CHINA.

(2) SAM OB: ADIC 0771, 3361, 9555, AND 2491.

G. THROUGH I. ADIC 1171.

T O P S E C R E T

BT

[Handwritten signatures and initials]

ILLEGIB

Declassified in Part - Sanitized Copy Approved for Release 2013/06/12 : CIA-RDP69B00041R000200040001-2

Page Denied

Declassified in Part - Sanitized Copy Approved for Release 2013/06/12 : CIA-RDP69B00041R000200040001-2

20207

T O P S E C R E T 182032Z CITE ADIC 2784

IMMEDIATE INFO IMMEDIATE

50X1

REALM 54

18 JUN 67 20 51z

A. BX6705

B. MISSION ALERT MSG

C. 20/0220Z

D.

50X1

E. NORTH VIETNAM

F. TYPE I CAMERA, BIRDWATCHER, PIN PEG, BIG BLAST, BLUE DOG II, SIP ON SYSTEM VI.

G. BACKUP ACFT REQUIRED. WHERE POSSIBLE SAME EQUIPMENT AS PARA F.

H. (1) DTFC TO LAUNCH BACKUP ACFT AT APPROX 20 JUN/0320Z

IN EVENT PRIMARY ACFT GROUND/AIR ABORTS. (2) THIS ALERT FOR

BLACK SHIELD CANNED MSN NBR EIGHT. (3) REQUEST CONFIRMATION

(REALM 57) SOONEST. (4) TYPE I DESIRED HOWEVER TYPE II ACCEPTABLE

IN EVENT ACFT 129 UTILIZED AND NOT CAPABLE ACCEPTING

TYPE I. PLS ADVISE SOONEST PACKAGE CONFIGURATION

IN PRIMARY AND SPARE ACFT.

(5) STEEL BRIDGE BEING UTILIZED VICE SCOPE RIPPLE DUE OVERALL WX/ROUTE CONSIDERATIONS.

T O P S E C R E T

BT

Handwritten notes: a circled '3' and several illegible signatures or initials.

30208

TOP SECRET 182036Z CITE ADIC 2786

JUN 67 20 54z

IMMEDIATE INFO PRIORITY

50X11

REALM 72I

- A. BX6705
- B. TANKER MSN ALERT MSG
- C. REQUEST ALERT OF TANKER FORCES
- D. 20 JUN/0220Z
- E. REQUEST CONFIRMATION SOONEST.

Handwritten notes:
NVA
2
W/O

TOP SECRET

BT

WECEN 232 [redacted]

50X1

Declassified in Part - Sanitized Copy Approved for Release 2013/06/12 : CIA-RDP69B00041R000200040001-2

TOP SECRET

[redacted]

ILLEGIB

TOP SECRET [redacted]

IMMEDIATE WECEN [redacted]

50X1

REALM 232

A. BX6705

B. 20/0344Z TO 0626Z JUN 67

C. [redacted] 20/0220Z/0715Z JUNE 67

50X1

D. WITHIN 22595 22520 23030 21050 21050 2305. TGTS: MANY

E. CANNED RTE NER 8: A/R'S SURE HIT ARCP 042Z STEELE BRIDGE ARCP 0420Z (1ST LOOP) AND 0541Z (2ND LOOP).

F. TANKER RTES: SEE COLOR 4513. I/O ON STN 1 HR PRIOR ARCP. [redacted]

APPROX: KADENA SURE HIT KADENA (STD 20/185Z)

KADENA STEELE BRIDGE KADENA (STD 19/2255Z)

KADENA STEELE BRIDGE KADENA (STD 20/0031Z)

G. TRMLS FOR REALM 236A (FROM WECEN): KADENA, NAHA, BAN TAKHL [redacted]

50X1

TADYUAN AND UTAROA. VLD ENTIRE [redacted]

[Large redacted area]

TOP SECRET

ILLEGIB

BT

[Handwritten signature]

✓	REALM	TITLE	DUE		IN	OUT	ACTION	REMARKS
			LOL	Z				
✓	231	Msn Alert WX Fcst	- 25		X		WX	
✓	20	Afld Status	Daily			X	DCO	As of 0900L
✓	72 T	Tnkr Msn Alert	- 24		X		SAC	
			1120	0220				
✓	54	Mission Alert	- 24		X		Cmdr DCO DCM	
			1120	0220				
✓	232	Mission Plan WX Requirements	- 23		X		WX DCO	
			1220	0320				
✓	62	Opnl Commo Data	- 22		X		COMMO DCO	
			1320	0420				
✓	63	EWS Setting	- 22		X		EWS	
			1320	0420				
✓	X	Tanker/Wx Scout Recall Word	- 22		X		DCO SAC	
			1320	0420				
✓	57	Mission Alert Confirmation	- 21			X	DCO	
			1320	0420				
✓	58 T	Tanker Support Confirmation	- 21			X	SAC	
			1420	0520				
✓	233	Msn Pln Wx Fcst	- 21		X		WX	
			1420	0520				
✓	236A	Forward Base Wx Fcsts	- 21		X		WX	
			1420	0520				
✓	313th	Grey Star Inten- tion Alert	- 20			X	DCO	BYEMAN CHANNELS
			1420	0520				
✓	71	Mission Plan #1	- 18		X		FltPln	
			1720	0820				

(18Jun67)

BLACKSHIELD*								
✓	REALM	TITLE	DUE		IN	OUT	ACTION	REMARKS
			LCL	Z				
✓	77	Current Intel	- 18		X		INTEL	
			1720	0826				
✓	233 Amnd	Msn Pln Wx Fcst	- 17:30		X		WX	
			1750	0850				
✓	236B	Forward Base Wx Fcst	- 17:15		X		WX	
			1805	0905				
✓	21	Opnl Capability	Daily NLT 1000Z			X	DCM	As of 1700 Local
			1900	1000				
✓	76	Mission Plan #2	- 15		X		FltPln	Probably 1004
			2020	1120				
✓	78	Mission Plan #3	- 15		X		FltPln	Probably 1004
			2020	1120				
✓	234	GO-NO-GO Wx Requirements	- 15		X		WX	
			2020	1120				
✓	30	Support Acft Stat	Daily NLT 1100Z			X	DCM	As of 1700 Local
			2000	1100				
✓	237	Tnkr Msn Wx Fcst	- 14		X		SAC WX	
			2120	1220				
✓	79T	Tnkr Msn Plan	- 13		X		SAC	
			2220	1320				
✓	81	Camera Programming Data	- 12:30		X		FltPln	1004
			2250	1350				
✓	313th	Grey Star Support Request	- 12			X	DCO	BYEMAN CHANNELS
			2220	1326				
✓	82	HFSSB Birdwatcher Activity	- 10			X	COMMO	
			0120	1620				
✓	42	NonOpnl Sortie	Daily NLT 2400L			X	DCO	Submitted for next day's Non Operational sorties
			2300	1400				

(18Jun67)

✓	REALM	TITLE	DUE		IN	OUT	ACTION	REMARKS
			ICL	Z				
✓	35	Special Fuel Test	- 10			X	DCM	
			0120	1620				
✓	236C	Forward Base Wx Fcst	- 9			X	WX	
			0220	1720				
✓	87T	Tanker Pre-Sortie Report	- 9			X	SAC	
			0220	1720				
✓	235	GO-NO-GO Wx Forecast	- 9		X		WX	(ADIC 2803 #20)
			0220	1820				
✓	86	Pre-Sortie Rpt	- 9			X	DCO	
			0220	1720				
—	241	Haz Wx Advisory	- 7			X	WX	If Adverse Conditions
			0420	1920				
—	241	Haz Wx Advisory	- 7		X		WX	If Adverse Conditions
			0420	1920				
✓	95T	Tanker Msn Support Execution	- 6		X		SAC	
			0520	2020				
✓	92	Emerg Seat. Pack	- 5			X	SECURITY	
			0620	2120				
✓	236D	Forward Base Wx Forecast	- 3			X	WX	
			0820	2320				
✓	243	Met Watch Obs	- 3			X	WX	
			0820	2320				
✓	313th	Grey Star Coord Confirmation	- 3		X		DCO	
			0820	2320				
✓	235 Amnd	GO-NO-GO Wx Forecast	- 3		X		WX	(ADIC 2803 #20)
			0920	2220				
✓	X	Coord Confirm	- 2:30			X	DCO	Submit to Hqs
			0750	2250				

(18 Jun 67)

✓	REALM	TITLE	DUE		IN	OUT	ACTION	REMARKS
			LCL	Z				
✓	240	Wx Scout Rpts	- 2		X		WX	Will be received continuously til AR Areas secured
			0920	0020				
✓	20	Afld Status	Daily			X	DCO	As of 0900 Local
			0800	2300				
✓	90	GO-NO-GO	- 1		X		DCO	
			1020	0120				
✓	103	Take-off	ASAP			X	DCO	
			1120	0220				
—	109	Abort	As Required			X	DCO	"FLASH"
✓	107	Mission Landing	ASAP			X	DCO	
✓	X	Birdwatcher Resume	L + ASAP			X	COMMO	
✓	111	Msn Post Indg	L + 2			X	DCO FltPln	
✓	117	Camera Configuration	L + 3			X	DCM	
✓	118	Mission Report	L + 3			X	DCO	INFO: CABLE "Eyes Only Cmdr"
✓	X	Opnl Sortie Rpt	ASAP			X	DCO	Same as NonOp Realm 47
✓	113	INS Tape	ASAP			X	FltPln	Via 1004 with message back-up
✓	119	Take Progress	ASAP after Take Departure			X	SECURITY	
✓	127	Final Field Eval Of INS Data	L + 24			X	DCM	

(18Jun67)

	REALM	TITLE	DUE		IN	OUT	ACTION	REMARKS
			ICL	Z				
✓	120	Flash Process	ASAP after Processing		X		FltPln	
✓	122	Film Evaluation	Developed + 12		X		FltPln	
✓	121	INS Tape Eval	NPIC Receipt + 2		X		FltPln	
✓	129	INS Film Correlation	L + 7 Days		X		FltPln	

(18 Jun 67)

FROM: Mission Coordinator

19 June 1967

SUBJECT: Mission Alert Notification

TO: (See below)

Request your attendance at the Commander's Briefing to be held in the Operations Briefing Room on 19 JUNE 1967 at 1150 L. The briefing concerns the following:

1. Mission Code Name and Number: 2-1073
2. Date/Time of Launch (H-Hour): 20 / 0220 Z / 1120 L.
3. Ground Spare (H+1:00): 20 / 0320 Z / 1220 L.
4. ~~General Area of Operation~~ N/R
5. Bases: Takeoff KADENA, Staging _____, Landing KADENA.
6. Equipment required: TYPE I, BW, PIN PEG, BIG BLAST, BLUE DOG II, SIP ON SYSTEM 6
7. Ground Spare Requirements: SAME AS Pri. where POSSIBLE.
8. Special Instructions/Comments: LAUNCH BACK UP AT 1220H IF Pri ABOYTS. BX CANCELED Mission # 8.

FOR THE COMMANDER

Mission Coordinator

Office	Time (L)	Recipient	Office	Time (L)	Recipient
CMDR	<u>0835</u>	<u>F.A.</u>	DCOL	<u>0736</u>	<input type="checkbox"/>
DCO	<u>0728</u>	<u>DK</u>	DCOC/MC	<u>0720</u>	<u>Rnd</u>
DCM	<u>0728</u>	<u>Ch</u>	DCOMI	<u>0735</u>	<u>RB</u>
DCS	<u>0835</u>	<u>F.A.</u>	DCOW	<u>0735</u>	<u>SD</u>
SECUR	<u>0737</u>	<u>MAK</u>	CONMO	<u>0740</u>	<u>H</u>
FLT SURG	<u>0748</u>	<u>Hef</u>	AECS	<u>0800</u>	(Notify Only)
DCOM	<u>0140</u>	<u>Jch</u>	TTF(SAC)	<u>WAW</u>	(Notify Only)

50X1

FROM: START

TO: H-24 (1120 L)

REALM MESSAGES OUT

<u>TIME (NLT)</u>	<u>MSG</u>	<u>ACTION</u>	<u>INFO</u>	<u>MSG FILE NO.</u>
		None		

REALM MESSAGES IN

<u>TIME (NLT)</u>	<u>MSG</u>	<u>ACTION</u>	<u>INFO</u>	<u>MSG FILE NO.</u>
1. H-24(<u>1120 L</u>)	72T from ADIC	TTFC	DCOC	<u>2</u>
2. H-24(<u>1120 L</u>)	54 from ADIC	CMDR, DCOC COMMO		<u>3</u>

CHECK LIST

<u>TIME (NLT)</u>	<u>RESPONSIBILITY</u>	<u>ACTION</u>	<u>COMP</u>
1. ASAP	DCOC	Complete & distribute mission alert notification.	<u>0720</u>
2. ASAP	DCOC	Convert H-hour time to local & record in check list.	<u>0730</u>
3. ASAP	DCOC	Include the following Realm checks in M/C check list.	<u>0740</u>
		(a) Realm 20, Daily, NLT 0930L ✓	
		(b) Realm 21, Daily, NLT 1800L ✓	
		(c) Realm 30, Daily, NLT 1800L ✓	
4. ASAP	DCO	Establish work schedule assign clerks to mission coordinator.	<u>✓</u>
5. ASAP	DCOC	NOTIFY RAPERON AND CHUPPER. ON A MISSION. NOTIFY CHUPPER & C-130	<u>✓</u>

MAN AND NEWTON
NOTIFIED CBS FOR
H. CONRAD TARRANT
ON 20/0930L

XERO COPY

XERO COPY

XERO COPY

XERO COPY

FROM: H-24(1120 L)

TO: H-23(1220 L)

REALM MESSAGES OUT

<u>TIME (NLT)</u>	<u>MSG</u>	<u>ACTION</u>	<u>INFO</u>	<u>MSG FILE NO.</u>
		None		

REALM MESSAGES IN

<u>TIME (NLT)</u>	<u>MSG</u>	<u>ACTION</u>	<u>INFO</u>	<u>MSG FILE NO.</u>
H-23(<u>1220</u> L)	232 from ADIC	DCOW, DCO DCOC		<u>1</u>

CHECK LIST

<u>TIME (NLT)</u>	<u>RESPONSIBILITY</u>	<u>ACTION</u>	<u>COMP</u>
H-23:30(<u>1150</u> L)	DCOC/MC	M/C attend Commander's initial briefing.	<u>✓</u>
H-23(<u>1220</u> L)	SECURITY	Hangars secured, access lists posted.	<u>150 ✓</u>
1125 L	DCOM	ACCESS LIST TO SECURITY	<u>✓</u>

XERO COPY

XERO COPY

XERO COPY

✓

XERO COPY

FROM: H-23 (1220 L)

TO: H-22 (1320 L)

REALM MESSAGES OUT

<u>TIME (NLT)</u>	<u>MSG</u>	<u>ACTION</u>	<u>INFO</u>	<u>MSG FILE NO.</u>
		None		

REALM MESSAGES IN

<u>TIME (NLT)</u>	<u>MSG</u>	<u>ACTION</u>	<u>INFO</u>	<u>MSG FILE NO.</u>
H-22(<u>1320 L</u>)	Realm X from SAC (Tnkr & Wea recall word)	DCOC		<u>8</u>
H-22(<u>1320 L</u>)	Realm 62 from ADIC	COMMO DCOC		<u>7</u>
H-22(<u>1320 L</u>)	Realm 63 from ADIC	EWS		<u>#13</u>

CHECK LIST

<u>TIME (NLT)</u>	<u>RESPONSIBILITY</u>	<u>ACTION</u>	<u>COMP</u>
H-22:30(<u>1250 L</u>)	DCM	Start mission Acft preflight (Item 7)	#1 <u>✓</u> #2 <u>✓</u>
H-22:30(<u>1250 L</u>)	FLT SURG	Start Pilot Physical	<u>✓</u>
H-22(<u>1320 L</u>)	DCOL	Start pre-flight suits and equip.	<u>✓</u>
H-22(<u>1320 L</u>)	DCM	Start TEB, LOX, & Refuel. (Item 11)	#1 <u>✓</u> #2 <u>✓</u>
H-23(<u>1220 L</u>)	COMMO	- L-62 INFO	<u>✓</u>

XERO COPY

XERO COPY

XERO COPY

XERO COPY

FROM: H-22 (1320 L)

TO: H-21 (1420 L)

REALM MESSAGES OUT

<u>TIME(NLT)</u>	<u>MSG</u>	<u>ACTION</u>	<u>INFO</u>	<u>MSG FILE NO.</u>
H-21(<u>1420</u> L)	57 (Mission alert confirmation)	M/C		✓ <u>4</u>
H-21(<u>1420</u> L)	58T (Tanker support confirmation)	STFC		<u>2</u>

REALM MESSAGES IN

<u>TIME(NLT)</u>	<u>MSG</u>	<u>ACTION</u>	<u>INFO</u>	<u>MSG FILE NO.</u>
H-21(<u>1420</u> L)	233 (Mission plan Wx forecast) From WECEN	DCOW		* <u>15</u>
H-21(<u>1420</u> L)	236A (Kadena Wx forecast) From WECEN	DCOW		* <u>14</u>

CHECK LIST

<u>TIME(NLT)</u>	<u>RESPONSIBILITY</u>	<u>ACTION</u>	<u>COMP</u>
H-21:30(<u>1350</u> L)	Flt Surgeon	Results of Flt Physicals	✓

XERO COPY

XERO COPY

XERO COPY

XERO COPY

FROM: H-21 (1420 L)

TO: H-20 (1520 L)

REALM MESSAGES OUT

<u>TIME(NLT)</u>	<u>MSG</u>	<u>ACTION</u>	<u>INFO</u>	<u>MSG FILE NO.</u>
H-20 (<u>1520</u> L)	Grey Star Intentions Alert MUST INCLUDE HF CALL SIGNS	M/C		<u>3</u>

REALM MESSAGES IN

<u>TIME(NLT)</u>	<u>MSG</u>	<u>ACTION</u>	<u>INFO</u>	<u>MSG FILE NO.</u>
------------------	------------	---------------	-------------	---------------------

CHECK LIST

<u>TIME(NLT)</u>	<u>RESPONSIBILITY</u>	<u>ACTION</u>	<u>COMP</u>
H-20 (<u>1520L</u>)	COMMO	Notify DCM of frequency channel- ization, and translator codes.	<u>✓</u>



FROM: H-20 (1520 L)

TO: H-19 (1620 L)

REALM MESSAGES OUT

<u>TIME(NLT)</u>	<u>MSG</u>	<u>ACTION</u>	<u>INFO</u>	<u>MSG FILE NO.</u>
------------------	------------	---------------	-------------	---------------------

REALM MESSAGES IN

<u>TIME(NLT)</u>	<u>MSG</u>	<u>ACTION</u>	<u>INFO</u>	<u>MSG FILE NO.</u>
------------------	------------	---------------	-------------	---------------------

CHECK LIST

<u>TIME(NLT)</u>	<u>RESPONSIBILITY</u>	<u>ACTION</u>	<u>COMP</u>
H-19(<u>1620</u> L)	DCM	Complete TEB, LOX, & Refuel (Item 11)	#1 <input checked="" type="checkbox"/> #2 <input checked="" type="checkbox"/>
H-19(<u>1620</u> L)	M/C	AFCS released for crew rest	<input checked="" type="checkbox"/>



FROM: H-19 (1620 L)

TO: H-18 (1720 L)

REALM MESSAGES OUT

<u>TIME(NLT)</u>	<u>MSG</u>	<u>ACTION</u>	<u>INFO</u>	<u>MSG FILE NO.</u>
------------------	------------	---------------	-------------	---------------------

REALM MESSAGES IN

<u>TIME (NLT)</u>	<u>MSG</u>	<u>ACTION</u>	<u>INFO</u>	<u>MSG FILE NO.</u>
H-18 (<u>1720</u> L)	71 (Mission Plan Msg) From ADIC	DCOMP		<u># 6</u>
H-18 (<u>1720</u> L)	77 (Current Intell) From ADIC	DCOMI		<u># 5</u>

CHECK LIST

<u>ME(NLT)</u>	<u>RESPONSIBILITY</u>	<u>ACTION</u>	<u>COMP</u>
H-18 (<u>1720</u> L)	DCM	Start INS Pre-flight (Item 16)	#1 <input checked="" type="checkbox"/>
H-18 (<u>1720</u> L)	DCOMI	Start Intell Briefing	#2 <input checked="" type="checkbox"/> <u>1720</u>
1620 h	SEC.	Receive SEAT Kit No. From SEC	#105 JLV <u>173 MV</u>

XERO COPY

XERO COPY

FROM: H-18 (1720 L)

TO: H-17 (1820 L)

REALM MESSAGES OUT

<u>TIME (NLT)</u>	<u>MSG</u>	<u>ACTION</u>	<u>INFO</u>	<u>MSG FILE NO.</u>
1830L	21	DCOL		<u>✓ 16</u>
1830L	30	DCOL		<u>✓ 17</u>

REALM MESSAGES IN

<u>TIME (NLT)</u>	<u>MSG</u>	<u>ACTION</u>	<u>INFO</u>	<u>MSG FILE NO.</u>
H-17:30 (<u>1756</u> L)	233 Amended (Msn plan Wx forecast) From WECEN	DCOW		<u># 17</u>
H-17:30 (<u>1750</u> L)	313 WX support confirmation from 313th.	DCO		<u># 16 -</u>
H-17:15 (<u>1805</u> L)	236B (Foreward base Wx forecast) From WECEN	DCOW		<u># 18</u>

CHECK LIST

<u>TIME (NLT)</u>	<u>RESPONSIBILITY</u>	<u>ACTION</u>	<u>COMP</u>
H-17 (<u>1826</u> L)	DCOL	Complete suit, equipment pre-flight.	<u>✓</u>

FROM: H-17 (1920 L)

TO: H-16 (1920 L)

REALM MESSAGES OUT

<u>TIME(NLT)</u>	<u>MSG</u>	<u>ACTION</u>	<u>INFO</u>	<u>MSG FILE NO.</u>
------------------	------------	---------------	-------------	---------------------

REALM MESSAGES IN

<u>TIME(NLT)</u>	<u>MSG</u>	<u>ACTION</u>	<u>INFO</u>	<u>MSG FILE NO.</u>
------------------	------------	---------------	-------------	---------------------

CHECK LIST

<u>TIME(NLT)</u>	<u>RESPONSIBILITY</u>	<u>ACTION</u>	<u>COMP</u>
H-16 (<u>1920</u> L)	DCM	Complete INS pre-flight (Item 16)	#1 <u>✓</u> #2 <u>L</u>
H-16 (<u>1920</u> L)	DCM	Start EWS pre-flight (Item 17)	#1 <u>L</u> #2 <u>✓</u>
H-16:30 (<u>1850</u> L)	SEC	PASS SCAT KIT NPS TO DDOC	<u>✓</u>

XERO COPY

XERO COPY

XERO COPY

FROM: H-16 (1920 L)

TO: H-15 (2020 L)

REALM MESSAGES OUT

<u>TIME(NLT)</u>	<u>MSG</u>	<u>ACTION</u>	<u>INFO</u>	<u>MSG FILE NO.</u>
------------------	------------	---------------	-------------	---------------------

REALM MESSAGES IN

<u>TIME(NLT)</u>	<u>MSG</u>	<u>ACTION</u>	<u>INFO</u>	<u>MSG FILE NO.</u>
H-15(<u>2020</u> L)	76 via 1004 (Mission Plan Two) From ADIC	DCOMP		<u>✓ 1004</u>
H-15(<u>2020</u> L)	78 (Mission Plan 3 in message form) From ADIC	DCOMP		<u># 12</u>
H-15(<u>2020</u> L)	234 (Go, No, Go Wx requirements) From ADIC	DCOW		<u># 20 (late)</u>

CHECK LIST

<u>TIME(NLT)</u>	<u>RESPONSIBILITY</u>	<u>ACTION</u>	<u>COMP</u>
H-15(<u>2020</u> L)	DCOM	START ON MAP STRIP	<u>✓</u>

Timing on the train 234 was changed to 1330Z regardless of H hour.



FROM: H-15 (2020 L)

TO: H-14 (2120 L)

REALM MESSAGES OUT

<u>TIME(NLT)</u>	<u>MSG</u>	<u>ACTION</u>	<u>INFO</u>	<u>MSG FILE NO.</u>
------------------	------------	---------------	-------------	---------------------

REALM MESSAGES IN

<u>TIME(NLT)</u>	<u>MSG</u>	<u>ACTION</u>	<u>INFO</u>	<u>MSG FILE NO.</u>
H-14 (<u>2120</u> L)	81 (Camera programming data) From ADIC	DCOM DCOC		<u>Received</u>
H-14 (<u>2120</u> L)	237 (Tanker mission WX Forecast) From WECEN	STFC	DCOW	<u>19</u>

CHECK LIST

<u>TIME(NLT)</u>	<u>RESPONSIBILITY</u>	<u>ACTION</u>	<u>COMP</u>
H-15 (<u>2020</u> L)	DCOM	Start on map strip	<input checked="" type="checkbox"/>
H-14 (<u>2120</u> L)	DCOMI	Give survival packet to DCOL	<input checked="" type="checkbox"/>
H-14 (<u>2120</u> L)	DCO	Coordinate with STFC on number of tankers required for Steel Bridge	<input checked="" type="checkbox"/>

FROM: H-14 (2220 L)

TO: H-13 (2220 L)

REALM MESSAGES OUT

<u>TIME(NLT)</u>	<u>MSG</u>	<u>ACTION</u>	<u>INFO</u>	<u>MSG FILE NO.</u>
------------------	------------	---------------	-------------	---------------------

REALM MESSAGES IN

<u>TIME(NLT)</u>	<u>MSG</u>	<u>ACTION</u>	<u>INFO</u>	<u>MSG FILE NO.</u>
H-13 (<u>2220</u> L)	79T (Tanker mission plan) From ADIC	STFC	DCOM DCOC	(3) [#] <u>9-10-11</u>

CHECK LIST

<u>TIME(NLT)</u>	<u>RESPONSIBILITY</u>	<u>ACTION</u>	<u>COMP</u>
H-13 (<u>2220</u> L)	DCM	Complete EWS pre-flight (Item 17)	#1 <input checked="" type="checkbox"/> #2 <input checked="" type="checkbox"/>
H-13 (<u>2220</u> L)	DCM	Start Package Load (Item 20)	#1 <u>3-15</u> #2 <u>2-5</u>

XERO COPY

XERO COPY

XERO COPY

XERO COPY

FROM: H-13 (2320 L)

TO: H-12 (2320 L)

REALM MESSAGES OUT

<u>TIME(NLT)</u>	<u>MSG</u>	<u>ACTION</u>	<u>INFO</u>	<u>MSG FILE NO.</u>
H-12(<u>2320</u> L) ACT. 1340L	Grey Star support Requirement	DCOC		<u>A 8</u>

REALM MESSAGES IN

<u>TIME(NLT)</u>	<u>MSG</u>	<u>ACTION</u>	<u>INFO</u>	<u>MSG FILE NO.</u>
------------------	------------	---------------	-------------	---------------------

CHECK LIST

<u>TIME(NLT)</u>	<u>RESPONSIBILITY</u>	<u>ACTION</u>	<u>COMP</u>
H-12(<u>2320</u> L)	FLT SUBG	PILOTS ASLEEP	<u>H-SLEEP</u>

XERO COPY

XERO COPY

XERO COPY

FROM: H-12 (2320 L)

TO: H-11 (0020 L)

REALM MESSAGES OUT

<u>TIME(NLT)</u>	<u>MSG</u>	<u>ACTION</u>	<u>INFO</u>	<u>MSG FILE NO.</u>
------------------	------------	---------------	-------------	---------------------

REALM MESSAGES IN

<u>TIME(NLT)</u>	<u>MSG</u>	<u>ACTION</u>	<u>INFO</u>	<u>MSG FILE NO.</u>
------------------	------------	---------------	-------------	---------------------

CHECK LIST

<u>TIME(NLT)</u>	<u>RESPONSIBILITY</u>	<u>ACTION</u>	<u>COMP.</u>
H-12()	Flt Surgeon	Pilots asleep	

H-11 (<u>0020</u> L)	DCM	SIP INSTALLED & checked. BEX CHECKED (ITEM 21)	<u>2315</u> <u>2325</u>
-----------------------	-----	--	----------------------------

XERO COPY

XERO COPY

XERO COPY

XERO COPY

FROM: H-11 (0120 L)

TO: H-10 (0120 L)

REALM MESSAGES OUT

<u>TIME(NLT)</u>	<u>MSG</u>	<u>ACTION</u>	<u>INFO</u>	<u>MSG FILE NO.</u>
H-10(<u>0120</u> L)	82 (HF/BW activity)	Commo		<u>1A</u>
H-10(<u>0120</u> L)	35 (Special fuel Tests)	POL		<u>7</u>

REALM MESSAGES IN

<u>TIME(NLT)</u>	<u>MSG</u>	<u>ACTION</u>	<u>INFO</u>	<u>MSG FILE NO.</u>

CHECK LIST

<u>TIME(NLT)</u>	<u>RESPONSIBILITY</u>	<u>ACTION</u>	<u>COMP</u>

XERO COPY

XERO COPY

XERO COPY

XERO COPY

FROM: H-10 (0720 L)

TO: H-9 (0220 L)

REALM MESSAGES OUT

<u>TIME(NLT)</u>	<u>MSG</u>	<u>ACTION</u>	<u>INFO</u>	<u>MSG FILE NO.</u>
H-9(<u>0220</u> L)	236C (Forward base WX Forecast)	DCOW		<u>19</u>
H-9(<u>0220</u> L)	86 (Pre sortie rpt)	DCO		<u>✓ 20</u>
H-9(<u>0220</u> L)	87T (Tanker pre-sortie report)	STFC	DCO, COMMO DCOM	<u>16.11.12</u>

REALM MESSAGES IN

<u>TIME(NLT)</u>	<u>MSG</u>	<u>ACTION</u>	<u>INFO</u>	<u>MSG FILE NO.</u>
H-9(<u>0720</u> L)	235 (Go-No-Go WX Forecast from WECEN)	DCOW		<u>21</u>

CHECK LIST

<u>TIME(NLT)</u>	<u>RESPONSIBILITY</u>	<u>ACTION</u>	<u>COMP.</u>

XERO COPY

XERO COPY

XERO COPY

XERO COPY

FROM: H-9 (0220 L)

TO: H-8 (0320 L)

REALM MESSAGES OUT

<u>TIME(NLT)</u>	<u>MSG</u>	<u>ACTION</u>	<u>INFO</u>	<u>MSG FILE NO.</u>
------------------	------------	---------------	-------------	---------------------

REALM MESSAGES IN

<u>TIME(NLT)</u>	<u>MSG</u>	<u>ACTION</u>	<u>INFO</u>	<u>MSG FILE NO.</u>
------------------	------------	---------------	-------------	---------------------

CHECK LIST

<u>TIME(NLT)</u>	<u>RESPONSIBILITY</u>	<u>ACTION</u>	<u>COMP.</u>
H-8:30(<u>0250</u> L)	DCM	Complete Package Load (Item 20)	#1 <input checked="" type="checkbox"/> #2 <input checked="" type="checkbox"/>
H-8:30(<u>0250</u> L)	DCM	Complete SIP & BCN (Item 21)	#1 <input checked="" type="checkbox"/> #2 <input checked="" type="checkbox"/>
H-8:30(<u>0250</u> L)	COMMO	Receive completed Commo flimsy (2 cys) deliver one copy to DCOM.	<input type="checkbox"/>
H-8(<u> </u> L)	APCS	Personnel return to duty	
H-8(<u>0320</u> L)	DCOM	Complete map strip	<u>Comp.</u>

XERO COPY

XERO COPY

XERO COPY

XERO COPY

FROM: H-8 (0420 L)

TO: H-7 (0420 L)

REALM MESSAGES OUT

<u>TIME(NLT)</u>	<u>MSG</u>	<u>ACTION</u>	<u>INFO</u>	<u>MSG FILE NO.</u>
H-7(<u>0420</u> L)	241 (If adverse Wx)	DCOW		_____

REALM MESSAGES IN

<u>TIME(NLT)</u>	<u>MSG</u>	<u>ACTION</u>	<u>INFO</u>	<u>MSG FILE NO.</u>
H-7(<u>0420</u> L)	241 (If adverse Wx)	DCOW		_____

CHECK LIST

<u>TIME(NLT)</u>	<u>RESPONSIBILITY</u>	<u>ACTION</u>	<u>COMP</u>
------------------	-----------------------	---------------	-------------

XERO COPY

XERO COPY

XERO COPY

XERO COPY

FROM: H-7 (0420 L)

TO: H-6 (0520 L)

REALM MESSAGES OUT

<u>TIME(NLT)</u>	<u>MSG</u>	<u>ACTION</u>	<u>INFO</u>	<u>MSG FILE NO.</u>
------------------	------------	---------------	-------------	---------------------

REALM MESSAGES IN

<u>TIME(NLT)</u>	<u>MSG</u>	<u>ACTION</u>	<u>INFO</u>	<u>MSG FILE NO.</u>
H-6(<u>0520</u> L)	95T (Tanker execution, delay or cancel) From ADIC	STFC	DCOC	<u>16</u>

CHECK LIST

<u>TIME(NLT)</u>	<u>RESPONSIBILITY</u>	<u>ACTION</u>	<u>COMP</u>
------------------	-----------------------	---------------	-------------

XERO COPY

XERO COPY

XERO COPY

XERO COPY

FROM: H-6 (0620)

TO: H-5 (0620)

REALM MESSAGES OUT

<u>TIME(NLT)</u>	<u>MSG</u>	<u>ACTION</u>	<u>INFO</u>	<u>MSG FILE NO.</u>
H-5(<u>0620</u>) L	92 (Contents of Emerg seat pack) To ADIC	SEC		<u>18</u>

REALM MESSAGES IN

<u>TIME(NLT)</u>	<u>MSG</u>	<u>ACTION</u>	<u>INFO</u>	<u>MSG FILE NO.</u>
------------------	------------	---------------	-------------	---------------------

CHECK LIST

<u>TIME(NLT)</u>	<u>RESPONSIBILITY</u>	<u>ACTION</u>	<u>COMP</u>
H-5(<u>0620</u>) L	AFCS	Personnel return to duty	<u> </u>

XERO COPY

XERO COPY

XERO COPY

XERO COPY

FROM: H-5 (0620)

TO: H-4 (0720)

REALM MESSAGES OUT

<u>TIME(NLT)</u>	<u>MSG</u>	<u>ACTION</u>	<u>INFO</u>	<u>MSG FILE NO.</u>
------------------	------------	---------------	-------------	---------------------

REALM MESSAGES IN

<u>TIME(NLT)</u>	<u>MSG</u>	<u>ACTION</u>	<u>INFO</u>	<u>MSG FILE NO.</u>
------------------	------------	---------------	-------------	---------------------

CHECK LIST

<u>TIME(NLT)</u>	<u>RESPONSIBILITY</u>	<u>ACTION</u>	<u>COMP</u>
H-4:30(<u>0650</u>)L	Flt Surgeon	Wake up pilots	<input checked="" type="checkbox"/>
H-4:30(<u>0650</u>)L	DCOM	Complete film strip	<input checked="" type="checkbox"/>
H-4:00(<u>0720</u>)L	AFCS	Send equip status : UCO	<input checked="" type="checkbox"/>
H-4:00 <u>0720L</u>	DCOC	MAKE A CHECK OF AIRFIELD STATUS	<input checked="" type="checkbox"/>



FROM: H-4 (0720 L)

TO: H-3 (0820 L)

REALM MESSAGES OUT

<u>TIME(NLT)</u>	<u>MSG</u>	<u>ACTION</u>	<u>INFO</u>	<u>MSG FILE NO.</u>
H-3(<u>0820</u> L)	236D (Fwd base Wea forecast)	DCOW		<u> </u>
H-3(<u>0820</u> L)	243 (Met watch Obs)	DCOW		<u> </u>

REALM MESSAGES IN

<u>TIME(NLT)</u>	<u>MSG</u>	<u>ACTION</u>	<u>INFO</u>	<u>MSG FILE NO</u>
H-3(<u>0720</u> L)	235 (GO-NO-GO Wx <i>AND</i> Fcst fm WECEN)	DCOW		<u> </u>
H-3(<u>0820</u> L)	Grey Star Support Requirement Confirm.	DCOC		<u> </u>

CHECK LIST

<u>TIME(NLT)</u>	<u>RESPONSIBILITY</u>	<u>ACTION</u>	<u>COMPLETE</u>
H-3:45(<u>0735</u> L)	DCO COMDR FLT SURG	Final decision on Primary & Spare pilot, notify DCOL.	<u> </u>
H-3:30(<u>0750</u> L)	DCM	Start INS warm (Item 30)	<u> </u>
H-3:30(<u>0750</u> L)	DCM	Start PE loading (Item 28)	<u> </u>
H-3(<u>0820</u> L)	DCM	Complete PE loading (Item 28)	<u> </u>
H-3:30(<u>0750</u>)	DCO	GIVE FINAL BRIEF.	<u> </u>

XERO COPY

XERO COPY

XERO COPY

XERO COPY

FROM: H-3 (0820 L)

TO: H-2 (0920 L)

REALM MESSAGES OUT

<u>TIME(NLT)</u>	<u>MSG</u>	<u>ACTION</u>	<u>INFO</u>	<u>MSG FILE NO.</u>
H-2:30(<u>0850</u> L)	X (Coordination confirmation)	DCOC		<u># 2</u>

REALM MESSAGES OUT

<u>TIME(NLT)</u>	<u>MSG</u>	<u>ACTION</u>	<u>INFO</u>	<u>MSG FILE NO.</u>
H-2(<u>0640</u> L)	240 (Wx scout rpts) From WECEN	DCOW		<u># 20 # 31</u>

CHECK LIST

<u>TIME(NLT)</u>	<u>RESPONSIBILITY</u>	<u>ACTION</u>	<u>COMP</u>

XERO COPY

XERO COPY

XERO COPY

✓

XERO COPY

FROM: H-2 (0112 L)

TO: H-1 (1020 L)

REALM MESSAGES OUT

<u>TIME(NLT)</u>	<u>MSG</u>	<u>ACTION</u>	<u>INFO</u>	<u>MSG FILE NO.</u>
0930 L	20	DCOC		<u>28</u>

REALM MESSAGES IN

<u>TIME(NLT)</u>	<u>MSG</u>	<u>ACTION</u>	<u>INFO</u>	<u>MSG FILE NO.</u>
H-1:30 (<u>0950</u> L)	240 (Wx Scout rpt)	DCOW		<u>✓ #31</u>
H-1 (<u>1020</u> L)	240 (Wx Scout rpt)	DCOW		<u>22</u>
H-1 (<u>1040</u> L)	90 (Go-No-Go msg) From ADIC	CMDR DCO		<u>* 29</u>

CHECK LIST

<u>TIME(NLT)</u>	<u>RESPONSIBILITY</u>	<u>ACTION</u>	<u>COMP</u>
H-1:35 (<u>0945</u> L)	DCOW	Letdown plates to pilots	<u>✓</u>
H-1:30 (<u>0950</u> L)	DCOM	Load both aircraft	#1 <u>✓</u> #2 <u>✓</u>
H-1:25 (<u>0955</u> L)	Flt Surgeon	Pre-suiting Physical	<u>✓</u>
H-1:00 (<u>1020</u> L)	DCOL	Pilot to aircraft	<u>✓</u>
H-1:00 (<u>1020</u> L)	DCO	Go-No-Go decision	<u>✓</u>
H-1:00 (<u>1020</u> L)	DCOC	Activate HF	<u>✓</u>
H-1:00 (<u>1020</u> L)	DCOC	Check latest NOTAMS	<u>✓</u>

XERO COPY

XERO COPY

XERO COPY

XERO COPY

PRIMARY

FROM: H-1 (1020 L)

TO: H (1120 L)

REALM MESSAGE OUT

<u>TIME(NLT)</u>	<u>MSG</u>	<u>ACTION</u>	<u>INFO</u>	<u>MSG FILE NO.</u>
ASAP after Launch	103	DCOC		
<i>A 10 AFTER LAUNCH</i>	<i>(103)</i>	<i>DCOC</i>		
	<i>START (A-1)</i>			

REALM MESSAGE IN

<u>TIME(NLT)</u>	<u>MSG</u>	<u>ACTION</u>	<u>INFO</u>	<u>MSG FILE NO.</u>
------------------	------------	---------------	-------------	---------------------

CHECK LIST

<u>TIME(NLT)</u>	<u>RESPONSIBILITY</u>	<u>ACTION</u>	<u>COMP</u>
H-:45 <i>(10351)</i>	DCOL	Pilot hooked up in acft	<input checked="" type="checkbox"/>
H-:30	<i>DCOC</i>	NOTIFY CHOPPER	<input checked="" type="checkbox"/>
H-:15	DCM	Start engine, tow #1	<input checked="" type="checkbox"/>



PRIMARY

FROM: H-Hour (1120 L)

TO: L-Hour (_____ L)

REALM MESSAGES OUT

<u>TIME(NLT)</u>	<u>MSG</u>	<u>ACTION</u>	<u>INFO</u>	<u>MSG FILE NO.</u>
ASAP after abort	109	DCOC		_____
ASAP after abort	313 abort msg	DCOC		_____

REALM MESSAGES IN

<u>TIME(NLT)</u>	<u>MSG</u>	<u>ACTION</u>	<u>INFO</u>	<u>MSG FILE NO.</u>
Anytime	240 (WX Scout Rpt)	DCOW		_____

CHECK LIST

<u>TIME(NLT)</u>	<u>RESPONSIBILITY</u>	<u>ACTION</u>	<u>COMP</u>
H+1:15	DCO	Release Spare	_____

PRIMARY

FROM: L-HOUR ()

TO: END ()

REALM MESSAGES OUT

<u>TIME(NLT)</u>	<u>MSG</u>	<u>ACTION</u>	<u>INFO</u>	<u>MSG FILE NO.</u>
ASAP after Lndg	X (B/W Resume)	COMMO		
ASAP after Lndg ASAP AFTER LNDG	107(MSN Lndg Rpt) GREY STAR CANX	DCOC		# 40
L+2:00() L)	111 Msn Post Lndg Report	DCOC		# 41
L+3:00() L)	117 (Camera Config Report)	DCM		R-III # 42
L+3:00() L)	118 (Msn Report)	DCO		OUT 40
L+3:30() L)	113 (INS Tape Report) (a 1004)	DCOM		QUITE WAY
ASAP after Take Departure	119 (Take Progress)	SECURITY		
L+24	1 (Final Eval of	DCM		

REALM MESSAGES IN

NONE SCHEDULED

CHECK LIST

<u>TIME(NLT)</u>	<u>RESPONSIBILITY</u>	<u>ACTION</u>	<u>COMP</u>
L+30() L)	AFCS	Shutdown	✓
L+30() L)	DCOC	RELEASE C-130	✓
L+3:30() L)	SECURITY	Sterilize Acft	
ASAP After Sterilization	DCOC	Release Acft	✓
L+5() L)	DCO	Review tanker mission report	✓
L+5() L)	DCOM	Tape of Debrief to Sec	✓
L+5() L)	COMMO	B/W tape to Security	✓
L+5() L)	SECURITY	Take to Courier Acft	

COPY

MISSION PILOTS ACTIVITY SCHEDULE FOR OPERATIONAL MISSION

<u>H-HOUR TIME</u>	<u>LOCAL TIME</u>	<u>ITEM</u>	<u>LOCATION</u>
H-22:30	<u>1250</u>	Pre-mission Physical Examination	Flt Surgeons Office
H-21:30	<u>1350</u>	Eating	Aircrew Mess
H-20:30	<u>1450</u>	Recreation activities as scheduled	Selected Area
H-18:00	<u>1720</u>	Intelligence Review	Intelligence Office
H-17:00	<u>1820</u>	Initial Briefing and Recreation	Briefing Room, Opns
H-14:00	<u>2120</u>	Eating	Aircrew Mess
H-13:00	<u>2220</u>	Crew Rest	Assigned House
H- 4:30	<u>0650</u>	Wake-up/Psychological Ck/Breakfast	Assigned House/Air- crew Mess
H- 3:30	<u>0750</u>	Final Briefing	Briefing Room/Opns
H- 1:40	<u>0940</u>	Final Physical Evaluation	Physiological Area
H- 1:25	<u>0955</u>	Suiting	Physiological Area
H- 1:05	<u>1015</u>	Leave Opns	Transport Van
H- 1:00	<u>1020</u>	Arrive Aircraft	Hangar
H- :45	<u>1035</u>	Complete Loading	Aircraft
H- :15	<u>1105</u>	Taxi	Aircraft
H- :05	<u>1115</u>	Engine Trim	Aircraft
H- :00	<u>1120</u>	Takeoff	Aircraft
L+ :25	_____	Post-Mission Physical Examination	Physiological Area
L+ :30	_____	Opns Debrief	Briefing Room/Opns
L+ :45	_____	Mission Debrief	Briefing Room/Opns
L+ 3:30	_____	Released	

Declassified in Part - Sanitized Copy Approved for Release 2013/06/12 : CIA-RDP69B00041R000200040001-2

Page Denied

Next 1 Page(s) In Document Denied

DCM 24 HOUR AIRCRAFT GENERATION CHECKLIST

PRE TAKE-OFF

H-HOUR 20/1120L

*ITEMS TO BE CALLED TO C.P.

Rev 5/31/67

	1	2	3	4	5	6	*7	8	9	10	*11	12
	DCM Alert Mtn to start generation	Cmdrs Initial Briefing	Select Acft & Assign Package	Mtn to Secure Nitrogen Oxygen	POL to Secure fuel trucks	DCM Mtng with Contract Pers	Start Mission Acft Preflt	Receive Ruel Load fm Flt Plan	Pers Eqp P/U LOX fm POL	REALM 63 to EWS & SIP	TEB, LOX & Refuel #1 & #2	ARC-50 Codes to DCM
H-HOUR	H-24 H-23:30	H-23:30	H-23:30 H-22:30	H-23:00	H-23:00	H-22:30	H-22:30	H-22:30	H-22:00	H-22:00	H-22:00 H-19:00	H-22:00
LOCAL TIME		1150					1250				1320	
#1 ACTUAL TIME 120							1100				1430	
#2 ACTUAL TIME							1100				1330	
	13	14	15	*16	*17	18	19	*20	*21	22	23	24
	COMMO & IFF Preflt	Install Instr	Select Recovery Crew & give to DCM	INS Preflt	EWS Preflt	Pkg Data avail fm Flt Plan	INS Data avail fm Flt Plan	Pkg Loaded in Acft #1 & #2	SIP Install checked out & Beacon Check	Pkg Data Loaded	INS Data Prepared for Loading	POL Send Realm 35
H-HOUR	H-22:00 H-18:00	H-20:00 H-18:00	H-20:00 H-16:00	H-18:00 H-16:00	H-16:00 H-13:00	H-13:45	H-12:45 H-12:00	H-13:00 H-8:30	H-11:00 H-8:30	H-11:00 H-8:30	H-11:00 H-6:00	H-10:45
LOCAL TIME			1520	1720	1920			2220	0020			
#1 ACTUAL TIME 129			1920	1920	2220			0250	0250			
#2 ACTUAL TIME 131				0630	1545			2115	2215			
				0930	1605			2400	2325			
				1700	1620			2115	2225			
				1935	1635			0020	2320			

JUN 06 1967

DCM 24 HOUR AIRCRAFT GENERATION CHECKLIST

PRE TAKE-OFF

H-HOUR _____

* INDICATES ITEMS TO BE CALLED TO C.P.

Rev 5/31/67

	25	26	27	*28	29	*30	31	32	33	34	35	*36
	Crew Chief Standby Acft	Mtn call Security to Sterlize Cockpit	Nitrogen Top Off	Pers Eqp Loaded	Acft Status Brief CC, INS, EWS, Pkg & DCM	Start INS Warmup	Pkg II Preheat	Pkg I Helium Purge Q-Bay	View-finder loaded with film	INS Data Tape Loading	Engineer Cock Acft	Engine Start, Power Switch & Towout #1
H-HOUR	H-4:00 H-Hour	H-4:00 H-3:30	H-4:00 H-3:30	H-3:30 H-3:00	H-3:30	H-3:30	H-3:30	H-2:00	H-2:00 H-1:30	H-2:00 H-1:30	H-1:30 H-1:00	H-:35 H-:15
LOCAL TIME				0750 0820		0750						1045 1105
#1 ACTUAL TIME				0750		0800						1050
#2 ACTUAL TIME				0745 0800		0745						
	37	38										
	Taxi & Take Off	Monk Rec & gather Rec Gear										
HOOR	H-:15 H-Hour	H-Hour H+1:00										
#1 ACTUAL TIME	129 1125 1117											
#2 ACTUAL TIME	131											

JUN 06 1967

Rev 5/31/67

	39	40	41	42	43	44	45	46	47	48	49	50
	Standby Spare Acft & Start Engines	Unload Pkg & INS from Spare Acft	Spare Acft Declas	Remove View-finder Film & Map fm Spare	Land & Cool Mission Acft	Secure Mission Acft & Service Engine Oil	SCDM Tape removed & Given to SIP	Remove View-finder Film & Maps	Remove Blue Dog Tape	Acft Mtn Debrief	Remove Instr Pkg	Move Acft In Hangar
H-HOUR	H+:25	H+:30 H+:30	H+:2:30	H+:2:30	L+:30	L+:30 L+:1:15	L+:30 L+:1:15	L+:30 L+:1:15	L+:30 L+:1:15	L+:4:5	L+:1:00	L+:1:15 L+:1:30
LOCAL TIME												
#1 ACTUAL TIME												
#2 ACTUAL TIME												
	51	52	53	54	55	56	57	58	59	60	61	
	Unload Pkg & Prepare "TAKE"	INS Erase Data fm Computer	SCDM Data to Flt Plan for Realm 113	SIP Data to OPS	Declass Mission Acft	Pkg "TAKE" to Security	Pkg Submit Realm 117 to DCM	Blue Dog Tape to Security	INS/SCDM Tab Run to Security	INS Send SCDM Tape to Security	INS Submit Realm 127 to DCM	
H-HOUR	L+:2:30 L+:3:30	L+:2:00 L+:3:00	L+:3:30	L+:3:30 L+:4:15	L+:4:00	L+:5:00	L+:5:00	L+:5:00	L+:5:00	L+:9:00	L+:20:00	
LOCAL TIME												
#1 ACTUAL TIME												
#2 ACTUAL TIME												

XERO COPY

XERO COPY

JUN 0 1967

MESSAGE TRAFFIC LOG

MSG #	REALM #	TIME SENT	CITE	ACTION	REMARKS	STAT
1	20	18/2345		MIC		
2	58T	18/2345Z		SAC		
3	GREY STAR INT.	18/2306Z	3137H	MIC		
4	57	18/2258Z		MIC		STAT
5	X	18/2304Z		MIC		
6	X	18/2235Z		MIC		
7	X	19/0010Z		SAC		
8	GREY STAR REG	19/0605Z	3137H	MIC		
9	35	19/0405Z		POL		STAT
10	87T	19/0726		SAC		
11	87T	19/0716		SAC		
12	87T	19/0723		SAC		
13	GREY STAR	19/0810	3137H	MIC		
14	82	19/0833		CommD		STAT
15	35	19/0854		POL		
16	21	19/0905		DCM		
17	30	19/0852		DCM		
18	92	19/		SEC		
19	236C	19/1607		WX		
20	86	19/1635		DCO		
21	243	19/2204		WX		
22	236	19/2159		WX		
23	35	19/2211		DCM		
24	X	19/2316		DCO		
25	101T	19/2358		SAC		
26	101T	19/2347		SAC		
27	101T	19/2347		SAC		
28	20	20/0006		DCO		
29	X	20/0006		DIO		
30	35	19/2352		DEM		

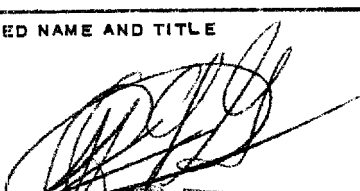
JOINT MESSAGEFORM			
SECURITY CLASSIFICATION SECRET			
TYPE MSG	BOOK	MULTI	SINGLE
PRECEDENCE			
ACTION PRIORITY			
INFO		DTG	
FROM: 		SPECIAL INSTRUCTIONS 50X1 1 SIG CEN 1 COMDR 50X1 1 DCM 1 DCO 1 INS	
TO: ADIC 			
REALM 127 A. BX 6705 B. FINAL FIELD EVALUATION OF INS DATA C. INS 010 D. LINE 031, DECK OFF FOR 09 MINUTES. NO EXPLANATION LINE 0384, DECK TURN OFF XXXXXXXX TRANSIENT LINE 0394, TRANSIENT, NO SCAN WAS MISSED LINE 0464, TRANSIENT, TWO SCANS MISSED LINE 0467, DECK OFF FOR 1 HOUR 30 MINUTES. NO EXPLANATION. END OF MESSAGE			
			50X1
DATE		TIME	
21			
MONTH		YEAR	
JUN		67	
PAGE NO.		NO. OF PAGES	
D R A F T E R	TYPED NAME AND TITLE	PHONE	SIGNATURE
			RE L E A S E D TYPED
SECURITY CLASSIFICATION SECRET			REGRADING INSTRUCTIONS

~~TOP SECRET~~ 202113Z GIFE [redacted]
IMMEDIATE [redacted] INFO PRIORITY ADIC
OXCART BLACK SHIELD SECUR
REALM X
REF: [redacted]

- A. BX6735
 - B. REVISED ETA OF C-141 TAIL NUMBER 8277 AC [redacted]
- ~~TOP SECRET~~
BT

21 16z
IS 21/07300.

50X1
50X1
50X1
50X1

NNNN

56

S-E C R E T 201614Z

50X1

IMMEDIATE ADIC

REALM 35

OX CART BLACK SHIELD MATERIEL

A. SPECIAL FUEL TEST REPORT (POST FLIGHT) BX 6705

B. 103 1415L/20

125 1430L/20

513 2020L/20

071 2030L/20

089 2200L/20

504 2240L/20

520 2300L/20

20 JUN 67 16 19z

C. FUEL TESTED IN PARA B QUALIFIED IAW SECTION VII TEST

CRITERIA

S E C R E T

BT

NNNN

55

JOINT MESSAGEFORM

SECURITY CLASSIFICATION

TOP SECRET

TYPE MSG BOOK MULTI SINGLE

PRECEDENCE

ACTION

INFO

DTG

~~IMMEDIATE~~
~~URGENT~~

FROM:

[Redacted]

TO:

AIEC

[Redacted]

SPECIAL INSTRUCTIONS

- 1 SIG GEN
- 1 COMDA
- 1 BOM
- 1 INS
- 1 BCO

50X1

50X1

REALM 113

- A. BX6705
- B. INS TAPE REPORT
- C. INS OLO
- D. DATA LINK
- E. 20/1400Z
- F. 4/1
- G. 670620-015140
- H. DATA GOOD

END OF MESSAGE

DATE	TIME
MONTH	YEAR
PAGE NO.	NO. OF PAGES

D R A F T E R	TYPED NAME AND TITLE	PHONE	R E L E A S E S	SIGNATURE
	[Redacted]			PREPARED (or stamped) NAME AND TITLE
	SECURITY CLASSIFICATION	[Redacted]		

50X1

Declassified in Part - Sanitized Copy Approved for Release 2013/06/12 : CIA-RDP69B00041R000200040001-2

T O P S E C R E T 201457Z CITE

50X1
50X1

IMMEDIATE ADIC,

REALM 113

- A. BX6705
 - B. INS TAPE REPORT
 - C. INS 010
 - D. DATA LINK
 - E. 20/1430Z
 - F. 21/1200Z
 - G. 670620-015140
 - H. DATA GOOD
- T O P S E C R E T
BT

20 JUN 67 14 42z

NN

Declassified in Part - Sanitized Copy Approved for Release 2013/06/12 : CIA-RDP69B00041R000200040001-2

20/1327Z ZFF-1 ZPO [redacted]

BT

XXXX

OPCEN 606 [redacted]

50X1

50X1

TOP SECRET 201326Z CITE [redacted]

IMMEDIATE ADIC INFO PRIORITY [redacted]

REALM 105T

50X1

50X1

A. BX6705

B. TANKER MISSION SUPPORT LANDING PERIOD

C. [redacted]

D. [redacted]

20/1252Z

20/1259Z

50X1

E. CODE II MAIN GEAR RETRACTION [redacted] ETC 21/1500Z

CODE II PRESSURIZATION AND GENERATOR MALFUNCTIONS ETC 21/1115Z

F. OFFLOADED NONE

OFFLOADED 60,000 LBS

G. NONE

TOP SECRET

BT

53

MESSAGE TRAFFIC LOG

MSG #	REALM #	TIME SENT	CITE	ACTION	REMARKS
31	101T	20/0125		SAC	50X1
32	101T	20/0127		SAC	
33	101T	20/0124		SAC	
34	101T	20/0126		SAC	
35	101T	20/0127		SAC	
36	103	20/0226		MC	
37	6054 STAN 2640	20/0225		MC	
38	105T	20/0553		SAC	
39	105T	20/0614		SAC	
40	107	20/0748		DCO	
41	GREEN STAN 2641	20/0748		MC	
42	111	20/0826		DCO	
43	X	20/0845		SAC	
44	X	20/0918Z		SAC	
45	X	20/0953		SAC	
46	X	20/0929		DCO	
47	105T	20/1147		SAC	
48	117	20/1020		MC	
49	118	20/1021Z		MC	
50	X	20/1045Z		MC	
51	119	20/1227		SEC/ASST	
52	105T	20/1251		SAC	
53	105T	20/1326		SAC	
54	113	20/1442		DCO	
55	35	20/1619		DCM	
56	X	20/2116		SEC	
57	127			DCM	

TOP SECRET

JITE

50X1

INFO CONTAINS ADIC

INFO CONTAINS

50X1

REAL: 1 52

50X1

A. BOX 6705

B. TANKER MISSION SUPPORT LANDING REPORT

C. [Redacted]

50X1

D. [Redacted] 20/1252 Z
20/1259 Z

50X1

E. CODE TR MANUEGAR RETRACTION TEST ETIC 21/1500 Z

CODE TR PRESSURIZATION AND GENERATOR MALFUNCTIONS 21/1800 Z
NONE ETIC.

F. CAPLOADED 60,000

G. NONE

END OF MESSAGE

TOP SECRET

ORIGINATOR'S SIGNATURE

[Redacted Signature Box]

50X1

20/1330 Z

20/1252Z ZFF-1 ZPO [redacted]

BT
XXXXX
OPCEN 605 [redacted]

TOP SECRET 201251Z CITE [redacted]
IMMEDIATE ADIC INFO PRIORITY [redacted]
REALM 1051

- A. BX6705
- B. TANKER MISSION SUPPORT LANDING REPORT
- C. [redacted]
- D. [redacted] 20/1229Z
- E. CODE 1
- F. OFFLOADED 1700H LBS
- G. NONE

TOP SECRET
BT

NNNN

52

50X1

50X1

50X1

50X1

50X1

TOP SECRET

CITE

50X1

IMMEDIATE ADIC ~~XXXXXXXXXX~~

INFO ~~XXXXXXXXXX~~

PRIORITY

50X1

REALM 105T

A. ~~BOX~~ 6705

B. TANKER MISSION SUPPORT LANDING REPORT

C.

50X1

D. 20/1229 Z
Z

50X1

E. CODE I

CODE _____

F. OFFLOADED 17,000 LBS

G. NONE

END OF MESSAGE

TOP SECRET

ORIGINATOR'S SIGNATURE

20/

50X1

Page Denied

Next 2 Page(s) In Document Denied

20 JUN 67 12

20/1156Z ZPO [redacted]

50X1

BT
XXXXX
OPCEN 600 CABLE 945 [redacted]

50X1

TOP SECRET 201045Z CITE [redacted]
PRIORITY ADIC INFO PRIORITY CABLE, [redacted]
REALM X

50X1

50X1

OXCART OPS/MAT/R&D

A. OPERATIONAL SORTIE REPORT

- B. (1) ARTICLE 129, FLT 217
- (2) SORTIE BX6705, DATE 20 JUN 67
- (3) PILOT: [redacted]
- (4) PURPOSE/ROUTE: BLACKSHIELD NBR 8
- (5) MISSION: SUCCESSFUL
- (6) TAKEOFF 0220Z, LANDED 0750Z, DURATION: 5:30
- (7) T.O. DIRECTION 230
- (8) T.O. GR WT: 106,600 LBS, 64.2% PERCENT
- (9) T.O. DIST: 5100 FT
- (10) T.O. SPEED 210 KTS
- (11) RWY TEMP: 82 DEGREES
- (12) WIND: 230/10
- (13) PRESSURE ALT 330 FT
- (14) MAX ALT: 82,000 FT
- (15) MAX MACH 3.15
- (16) AB TIME: LEFT 4:15 RIGHT 4:30
- (17) TIME AT OR ABOVE M2.0: 2:00
- (18) TIME AT OR ABOVE M2.6: 2:00
- (19) TIME AT OR ABOVE M2.8: 2:00
- (20) TIME AT OR ABOVE M3.0: 2:00
- (21) N/A
- (22) TOTAL ACFT TIME: 306:00
- (23) Q-BAY/SPECIAL EQUIP: PKG 0, SIP, EWS
- (24) CIT 380 DEGREES AT 3.10 MACH

50X1

C. SUMMARY: TAKEOFF NORMAL. TOPOFF AIR REFUELING COMPLETED WITH 67,100 LBS FUEL ONBOARD. ACCELERATION VERY SLOW THROUGH MACH 1. REST OF CLIMB NORMAL. 3.1 MACH CRUISE LEG WAS FLOWN. INS AUTONAV TURNS WERE ERRATIC AND TURNS HAD TO BE MADE MANUALLY. PACKAGE I FAILURE CAME ON WHEN PKG WAS TURNED ON. IT WAS RECYCLED SEVERAL TIMES AND REMAINED OFF AFTER 4TH RECYCLING. DESCENT NORMAL. AIR REFUELING COMPLETED WITH 67,800 LBS FUEL ONBOARD. CLIMB AND 3.1 MACH CRUISE NORMAL. PACKAGE I OPERATION NORMAL. DESCENT NORMAL. DURING 1ST RENDEZVOUS THE ARC-50 EXT ADF AND AR BEACON WERE INOPERATIVE. A/A TACAN WAS INOPERATIVE BOTH 2ND AND 3RD RENDEZVOUS. FINAL AR BEACON WAS INOPERATIVE. CLIMB AND 3.1 MACH CRUISE LEG NORMAL. PKG I OPERATION NORMAL. POSSIBLE EWS MALFUNCTION. ENGINE AND INLET OPERATION SATISFACTORY DURING ENTIRE FLIGHT. DESCENT AND LANDING NORMAL.

D. DISCREPANCIES:

- (1) INS STEERING EFFONEOUS DURING TURNS.
- (2) SR3 COMPASS 25 DEGREE IN ERROR (MAGNETIC).
- (3) A/A TACAN INOPERATIVE.
- (4) AR BEACON INOPERATIVE.
- (5) ARC-50 EXT ADF INOPERATIVE.
- (6) LEFT CIP INDICATION LAGS 10 SECONDS.
- (7) BIRDWATCHER INDICATED PKG LIGHT WHEN EWS WAS

TURNED ON EACH TIME.
TOP SECRET
BT

SO

20/1035Z ZFF-3
BT
XXXXX
OPCEN 594 CABLE 940

TOP SECRET 201031Z CITE [REDACTED]
IMMEDIATE ADIC INFO IMMEDIATE CABLE
OXCART BLACKSHIELD OPS
REALM 118
FOR CABLE (EYES ONLY COMMANDER)

50X1

A. BX6705
B. MISSION REPORT
C. SMOKE CLOUD OBSERVED AT 21-25N, 105-25E, POSSIBLY FROM OIL STORAGE TANKS. SMOKE CLOUDS OBSERVED AT APPROX 17-10N, 106-37E, WITHIN A 5NM RADIUS, POSSIBLY FROM OIL STORAGE TANKS. FIGHTER ACTIVITY PICKED UP ON UHF RADIO BETWEEN 20-37N, 106-40E AND 21-55N, 105-20E (APPARENTLY DOG-FIGHTING). PIN PEG RED LIGHT ACTIVE AT APPROX 18-02N, 109-37E. LIGHT ON FOR APPROX 30 SEC. LIGHT WENT OUT WHEN JAM OVERRIDE WAS DEPRESSED THE SECOND TIME.

D. INS CAUSED SOME DEVIATION IN TURN, BUT ROUTE WAS FLOWN AS BRIEFED DURING STRAIGHT AND LEVEL PORTIONS OF FLIGHT.

E. AT FIRST PACKAGE TURN ON POINT (PC04), PACKAGE FAIL LIGHT CAME ON. ACFT WAS IN A SLIGHT BANK AT THE TIME. PACKAGE WAS RECYCLED FOUR TIMES. AFTER 4TH RECYCLING, LIGHT REMAINED OFF FROM PC04/090. NO OTHER ACTION DEVIATIONS.

- F. PC04 TO PD02/090 -1
- PD02/090 TO PD03 -3
- PD03 TO PE01 -1
- PI01/305 TO QA01 -1
- QA01 TO QA01/115 -2
- QA01/115 TO QC01/080 -1
- QC01/080 TO QC02 -3
- QC02 TO QD01 -1
- QH01/303 TO RC02/210 -1

G. FUEL REMAINING AT START DESCENT 21,800 LBS.

H. PACKAGE TRANSPORTED 4200 FT OF WILM.

TOP SECRET
BT

NNNN

RESERVED FOR COMMUNICATION CENTER

JOINT MESSAGEFORM

SECURITY CLASSIFICATION

SECRET
TOP SECRET

TYPE: [] BOOK [] MULTIPLE []

PRECEDENCE

ACTION

IMMEDIATE

INFO

IMMEDIATE

DTG

FROM:

TO:

ADIC

INFO: CABLE

SPECIAL INSTRUCTIONS

- 1 SIG CEN
- 1 COMDR
- 1 DCM
- 1 P.E.
- 1 DCO

50X1
50X1
50X1
50X1

BRAIN 117

- A. BX6705
- B. ~~THE/UNION/COY/BOOK/TYPE I CAMERA CONFIGURATION REPORT~~
- C. I-G/JUNE 20/129, []
- D. 700/700
- E. 700/700
- F. 3403/2177/267 2/15 - 11 - 6
- G. 5.6/YELLOW, WRITTEN 12
- H. 72/74
- I. 83/85
- J. 69/60
- K. 0310Z/0402Z
- L. 0448Z/0526Z
- M. 0639Z/0651Z
- N. ENTIRE ROUTE/300/39 IN CLOUD
- O. NA
- P. AS BRIEFED - MOSTLY CLEAR.

DATE	TIME
MONTH	YEAR
PAGE NO.	NO. OF PAGES

TYPED NAME AND TITLE

PHONE

SIGNATURE

TOP SECRET

TYPED (or stamped) NAME AND TITLE

50X1

SECURITY CLASSIFICATION

SECRET

REGARDING INSTRUCTIONS

DD FORM 173
1 NOV. 63

REPLACES EDITION OF 1 MAY 55 WHICH MAY BE USED.

GPO 1966-206-552

15220

20/103 1Z ZFF-3 ZPO [redacted]

50X1

BT

XXXXX

OPCEN 593 [redacted]

CABLE 939 [redacted]

50X1

OPCEN PASS [redacted]

50X1

TOP SECRET 201028Z CITE [redacted]

50X1

IMMEDIATE ADIC, [redacted] INFO IMMEDIATE CABLE [redacted]

50X1

REALM 117

50X1

A. BX 6705

B. TYPE I CAMERA CONFIGURATION REPORT

C. I-G/JUNE 20/129 [redacted]

50X1

D. 700/700

E. 700/700

F. 3403/2177/267 2/15 - 11 - 6

G. 5.6/YELLOW, WRITTEN 12

H. 72/74

83/85

69/60

I. 0340Z/0402Z

0448Z/0526Z

0639Z/065 1Z

J. ENTIRE ROUTE/300/39 IN CLOUD

K. NA

L. AS BRIEFED - MOSTLY CLEAR

M. BS SECURITY 201020Z

N. SUCCESSFUL MISSION. DELAY RE MAY PERMITTED THREE RECYCLES AT

START OF INITIAL RUN.

TOP SECRET

BT

48

JOINT MESSAGEFORM - CONTINUATION SHEET

SECURITY CLASSIFICATION

TOP SECRET
50X1

FROM:



M.M. BS SECURITY 201000Z

N. SUCCESSFUL MISSION. DELAY RELAY PERMITTED THREE RECYCLES AT START OF INTIAL RUN.

END OF MESSAGE

SYMBOL

PAGE NR

NR OF PAGES

SECURITY CLASSIFICATION

INITIALS

DD FORM 173-1
MAY 55

28/1148Z ZFF-1 ZPO [redacted]

50X1

OPCEN 883 [redacted]

50X1

TOP SECRET 201147Z CITE [redacted]
IMMEDIATE ADIC INFO PRIORITY [redacted]
REALM 1051

ILLEGIB
50X1

- A. BX 6785
- B. TANKER MISSION SUPPORT LANDING [redacted]
- C. [redacted]

50X1

28/1243Z
28/1251Z

- E. CODE 1
- F. OFFLOADED 45M
- G. NONE

TOP SECRET
BT

NNNN

TOP SECRET

ORIG [redacted]

50X1

IMMEDIATE ADIC [redacted]

INFO [redacted]

PROTECTED [redacted]

50X1

REALM 105T

A. ~~SEE~~ BX 6705

B. TANKER MISSION SUPPORT LANDING REPORT

C. [redacted]

50X1

D. [redacted]

20/1043 Z
20/1051 Z

50X1

E. CODE

CODE

F. OFFLOADED

45 M

G. NONE

END OF MESSAGE

TOP SECRET

50X1

ORIGINATOR'S SIGNATURE [redacted]

Page Denied

413
200955Z ZFF-1 ZPO [redacted]

200955Z

50X1

BT
XXXXX
OPCEN 590 [redacted]

50X1

TOP SECRET 200953Z CITE [redacted]
IMMEDIATE ADIC INFO PRIORITY [redacted]
OXCART/BLACKSHIELD
REALM X

50X1

50X1

REF: [redacted]
1. 58-088, [redacted] ETIC 20/1300Z.
2. IN AS MUCH AS FLIGHT TIME TO [redacted] WOULD CAUSE CREW
TO EXCEED FLIGHT DUTY PERIOD LIMITATIONS WITH TAKE-OFF AFTER
ABOVE ETIC CREW HAS BEEN PLACED IN CREW REST.
3. ESTIMATE DEPARTURE UTAPAO 20/2330Z, ETA [redacted] 21/0400Z.

50X1

50X1

50X1

50X1

TOP SECRET
BT

Handwritten signature and initials, including a large '45' and a stylized signature.

NNNN

TOP SECRET

CITE

STAT

IMMEDIATE ADIC INTO PRIORITY

OX CART/BLACK SHIELD

REALM X

REF

STAT

STAT

STAT

1. SP-088, ETIC 20/1300Z.

2. ~~ETA~~ IN AS MUCH AS FLIGHT TIME TO

WOULD CAUSE CREW TO EXCEED ~~CREW~~

FLIGHT DUTY PERIOD LIMITATIONS WITH

TAKE-OFF ~~REAR~~ ABOVE ETIC CREW HAS

BEEN PLACED IN CREW REST.

3 ESTIMATE DEPARTURE WTAAO 20/2330Z,

ETA 21/0400Z.

STAT

Handwritten mark

STAT

20/1000Z

420
200920Z ZFF-1 ZFO [redacted]

BT
XXXXX
OPCEN 587 [redacted]

20 JUN 87

50X1

50X1

TOP SECRET 200918Z CITE [redacted]
IMMEDIATE ADIC INFO PRIORITY [redacted]
OXCART/BLACKSHIELD
REALM X (REALM 68T FORMAT)

A. BX 6705
B. TANKER DEPLOYMENT TAKE-OFF REPORT

C. 58-071, [redacted]
58-089,
59-1504
58-094,

D. TAKHLI, ATD UNK.
UTAPAO, ATD UNK.
UTAPAO, ATD UNK.
TAKHLI, 20/0844Z

E. N/A

F. [redacted] 20/1044Z
20/1200Z
20/1200Z
20/1244Z

G. 58-088, [redacted] LANDED UTAPAO 20/0822Z WITH
NO. 4 ENG SHUT DOWN DUE TO LOSS OF OIL PRESSURE. FURTHER INFO FOLLOW-
ING.

TOP SECRET
BT

50X1

50X1

50X1

50X1

50X1

NNNN

44

TOP SECRET

CITE

[Redacted]

STAT

IMMEDIATE ADIC INFO PRIORITY

[Redacted]

STAT

OXCART / BLACK SHIELD

REALM X (REALM 68T FORMAT)

A. BX 6705

B. TANKER DEPLOYMENT TAKE-OFF REPORT

C. 58-071,

~~58-073~~

58-089,

59-1504

58-094,

[Redacted]

STAT

STAT

D. TAKHLI, ATD UNK.

WTAPAO ATD UNK.

WTAPAO, ATD UNK.

TAKHLI, 20/0844Z

E. N/A

F.

[Redacted]

20/1044Z

20/1200Z

20/1200Z

20/1244Z

[Redacted] 20/0720Z

STAT

STAT

G. 58-088,

[Redacted]

LANDED WTAPAO

20/0822Z WITH NO. 4 ENG SHUT DOWN DUE TO

LOSS OF OIL PRESSURE. FURTHER INFO FOLLOWING.

STAT

20 JUN 67 07 52z

417

200847Z ZFF-1 ZPO [redacted]

BT
XXXXX
OPCEN 535 [redacted]

50X1

13 11
A

50X1

T O P S E C R E T 200845Z CITE [redacted]
IMMEDIATE ADIC INFO PRIORITY [redacted]
OXCART/BLACKSHIELD OPS
REALM X

50X1

50X1

- A. BX 6705
 - B. TANKER DEPLOYMENT TAKE-OFF REPORT
 - C. 58071, [redacted]
 - D. BAN TAKHLI, 20/0633Z
 - E. NA
 - F. [redacted] 20/1024Z
- T O P S E C R E T
BT

50X1

50X1

43

A

TOP SECRET

CITE

STAT
STAT

IMMEDIATE ADIC

INFO PRIORITY

~~SECRET~~

OXCART/BLACKSHIELD OPS
REALM X

A. BX 6705

B. TANKER ~~DEPLOYMENT~~ TAKE OFF REPORT STAT

C. 58051,

D. BAN TAKHLI, 20/0633Z

E. NA

F.

, 20/1024Z

STAT

STAT

20 JUN 67 07 26z

415

200818Z ZFF-1
BT
XXXXX
OPCEN 583

15209
EF

TOP SECRET 200816Z CITE
IMMEDIATE ADIC
OXCART/BLACKSHIELD/OPS
REALM 111

50X1

- A. PX-6705
- B. MISSION POST LANDING REPORT
- C. BETTER THAN BRIEFED - LOOKED BEAUTIFUL.
- D. WILL NOT AUTO NAV IN TURNS - SERVO MODE OF GYRO COMPASS INOP - BEACON INOP - ADF FUNCTION OF ARC 50 UNSATISFACTORY.
- E. AIRCRAFT RAN GOOD.
- F. CAMERA INDICATED MALFUNCTION ON FIRST THREE ATTEMPTS JUST PRIOR TO FIRST PENETRATION-THEN INDICATED OK REMAINDER OF FLIGHT.
- G. PILOT COULD HEAR UHF CONVERSATION OF AIR BATTLE TAKING PLACE. PILOT OBSERVED SMOKE NW HANOI ALSO IN DNZ AREA ON 3RD PASS. PILOT RECEIVED PIN PEG INDICATION AFEAM HAINAN ON DEPARTURE ROUTE HOME. UTILIZED JAM OVERRIDE. BW READOUTS AS FOLLOWS: 0647.30Z,

50X1

TOP SECRET
BT

NNNN

TOP SECRET

IMMEDIATE

TO: ADIC

CITE:

50X1

OX CART/BLACKSHIELD/OPS

REALM 111

A. BX-6705
(Msn #)

B. MISSION POST LANDING REPORT

C. Better than briefed - looked BEAUTIFUL
(WX - as briefed, better than briefed, worse than briefed)

D. Will NOT AUTO HOLD IN TURANS - SERF MODE OF
(Navigation) 9700 COM 112 111P - 13000 112P - 14000
FUNCTION OF ARE 150 UNUSUAL/SUCCESSORY

E. AIRCRAFT RAN GOOD.
(Acft malfunctions)

F. CAMERD INDICATED MALFUNCTION ON FIRST
(Equip malfunctions) THREE AIRCRAFTS JUST PRIOR TO

G. FIRST PENETRATION - BEEN INDICATED OK
(Comments) REMAINDER OF FLIGHT.

*Pilot could hear some conversation
of air battle taking place. Pilot
observed smoke and hand also in
DMZ AREA ON 3RD PASS. Pilot observed
Pin Peg indication during mission on
departure Route home. Utilized jam
override. BW Remarks as follows. 0647:30z*

50X1

50X1

20/8152

TOP SECRET

42
(16Jun67)

IMMEDIATE FOLLOWS
FROM DET 4, 313 ADIV
TO: AFSSO 313 ADIV
O 200748Z

BT
T O P S E C R E T BYEMAN CHANNEL
GREY STAR 06-41
THIS IS A GREY STAR CANCELLATION MSG:
A. BX-6705
B. CANCEL SUPPORT REQUIREMENT.
C. ATA 20/0745Z
BT

50X1

NNNN

XERO COPY XERO COPY XERO COPY XERO COPY

TOP SECRET

IMMEDIATE

FROM DET 4, 313ADIV

TO: AFSSO 313 ADIV

TOP SECRET BYEMAN CHANNEL

GREY STAR 06-41
(MSG NBR)

THIS IS A GREY STAR ~~XXXXXXXXXXXXXXXXXXXX~~ CANCELLATION MSG.

A. BX-6705
(MSN NBR)

B. CANCEL SUPPORT REQUIREMENT.

C. ATA 20/0745 Z.
(MSN ACFT UHF TACTICAL CALL SIGN ATA)

D. (COMMENTS) NA

50X1

50X1



20/1645 L

Det 4, 313th ADiv Format #3, 07 June 1967

TOP SECRET

(41)

20/0749Z ZFF-1 ZPO [redacted]

50X1

BT
XXXXX

OPCEN 582 [redacted]

50X1

T O P S E C R E T 200748Z CITE [redacted]

50X1

IMMEDIATE ADIC INFO PRIORITY [redacted]

50X1

OXCART/BLACKSHIELD/OPS

REALM 107

- A. BX-6705
- B. MISSION LANDING REPORT
- C. 129
- D. 20/0745Z
- E. NONE

T O P S E C R E T

BT

NNNN

XERO COPY

XERO COPY

XERO COPY

XERO COPY

TOP SECRET

IMMEDIATE

TO: ADIC

INFO: (PRIORITY)

CITE:

50X1

OXCART/BLACKSHIELD/OPS

50X1

REALM 107

A. BX-6705
(Msn #)

B. MISSION LANDING REPORT

C. 129
(Acft #)

D. 20/0745 Z
(Location and actual lndg time DTG(Z))

E. (Comments)

A

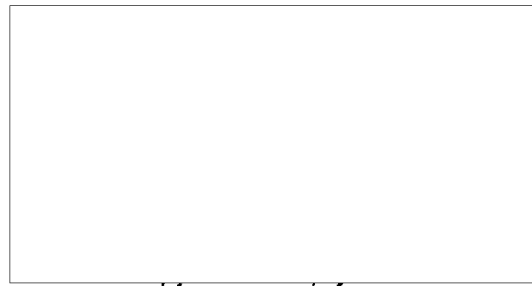

50X1

20/1645 L

TOP SECRET

40
(16 Jun 67)

200616Z ZFF-1 ZPO [redacted]

50X1

BT
XXXXX

OPCEN 579 [redacted]

50X1

T O P S E C R E T 200614Z CITE [redacted]

50X1

IMMEDIATE ADIC INFO PRIORITY [redacted]

50X1

REALM 105T

- A. BX6705
- B. TANKER MISSION SUPPORT LANDING REPORT

C. [redacted]

50X1

- D. U-TAPAO 20/0507Z
- U-TAPAO 20/0512Z

- E. CODE UNK
- CODE UNK

- F. OFFLOADED UNK
- G. MINIMUM GROUND TIME FOR UNLOADING JP-4

ITEM E AND F WILL BE REPORTED ON RETURN TO [redacted]

50X1

T O P S E C R E T

BT

TOP SECRET

CITE

50X1

IMMEDIATE ADIC

INFO

50X1

REALM 1053

A. ~~THE~~ BX 6705

B. TANKER MISSION SUPPORT LANDING REPORT

50X1

C.

D. ~~FROM~~ U-TAPAO 20/0507Z

~~TO~~ U-TAPAO 20/0512Z

E. CODE UNK

CODE UNK

F. OFFLOADED UNK

G. ~~MIN~~ MINIMUM GROUND TIME FOR

50X1

UNLOADING SP-4 (ITEM E AND F WILL BE

REPEATED ON RETURN TO

TOP SECRET

50X1

ORIGINATOR'S SIGNATURE

[Redacted Signature Box]

200555Z ZFF-1 ZPO [redacted]

BT
XXXXX

OPCEN 576 [redacted]

50X1

50X1

T O P S E C R E T 200553Z CITE [redacted]

IMMEDIATE ADIC INFO PRIORITY [redacted]
REALM 105T

50X1

50X1

A. BX6705

B. TANKER MISSION SUPPORT LANDING REPORT

C. [redacted]

50X1

D. [redacted] 20/0440Z
20/0505Z

E. CODE I
CODE I

F. OFFLOADED AS BRIEFED 34,000 LBS.

G. NONE

T O P S E C R E T

BT

NNNN

A

TOP SECRET _____

CITE

50X1

IMMEDIATE ADIC _____ INFO _____

50X1

REALM: 105F

A. ~~89X~~

~~6705~~

B. TANKER MISSION SUPPORT LANDING REPORT

C.

50X1

D.

50X1

~~20/0440~~
~~20/0505~~

E. CODE _____

CODE _____

F. OFFLOADED _____

~~AS BRIEFED 34,000 LBS.~~

G. NONE

END OF MESSAGE

TOP SECRET

50X1

ORIGINATOR'S SIGNATURE

082

20 JUN 67 03 25z

IMMEDIATE FOLLOWS
FM: DET 4 313ADIV
TO: AFSSO 313ADIV
O 200222Z

BT
T O P S E C R E T BYEMAN CHANNEL
GREY STAR 06-40
1. BX-6705
2. ATD 20/0219Z

BT

NNNN

Nguz

(37)

A

XERO COPY

XERO COPY

(No XERO Copy. Tko. Ldg)

XERO COPY

T O P S E C R E T

IMMEDIATE

FROM: DET 4 313ADIV

TO: AFSSO 313ADIV

TOP SECRET ~~SECRET~~ MAN CHANNEL

GREY STAR 06-40
(Msg #)

- 1. BX-6705
- 2. ATD 20/0219 Z



50X1

(Releaser & DTG)

20/1120 L

[Handwritten mark]

Det 4, 313th ADiv Format #7 15Jun67

T O P S E C R E T

348

20/07/02 02 05z

200225Z ZPZFF-4 ZPO
BT
XXXXX
OPCEN 568

[Redacted]

[Redacted]

T O P S E C R E T 200225Z CITE
IMMEDIATE ADIC INFO PRIORITY
OXCART BLACKSHIELD OPS
REALM 103
A. BX 6705
B. MISSION TAKE-OFF REPORT
C. NR 129
D. 2010/0219Z
E. SEAT KIT NUMBER 105.
T O P S E C R E T
BT

50X1
50X1
50X1
50X1

NW (36)

NNNN

TOP SECRET

IMMEDIATE

TO: ADIC

INFO: (PRIORITY)

CITE:

50X1

OXCART/BLACKSHIELD/OPS

50X1

REALM 103

A. BX-6705
(Msn #)

B. MISSION TAKE-OFF REPORT

C. # 129
(Acft #)

D. 2010219 Z
(ATD)

E. (Comments) SEAT KIT NUMBER 105

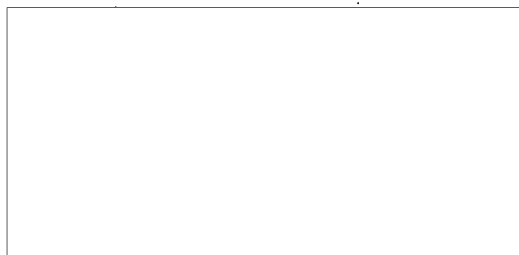

50X1

(Releaser & DTG)

20/1120 L

#36

TOP SECRET

(10Jun67)

200129Z ZFF-1 ZPO [redacted]

50X1

BT

XXXXX

OPCEN 566 [redacted]

50X1

T O P S E C R E T 200127Z CITE [redacted]

50X1

IMMEDIATE ADIC INFO PRIORITY [redacted]

50X1

REALM 101T

A. BX 6705

B. TANKER MISSION SUPPORT TAKE-OFF REPORT (AR TOP OFF)

C. [redacted]

50X1

D. 20/0106Z

E. NONE

T O P S E C R E T

BT

NNNN

Handwritten signature
A

TOP SECRET

GITS

IMMEDIATE ADIO

INFO PRIORITY

REAR 101T

A. ~~6705~~ 6705

B. TANKER MISSION SUPPORT ~~TOR OFF~~ REPORT

AR (TOR OFF)

C. ~~20/0106~~

D. 20/0106 2

E. NONE

END OF MESSAGE

TOP SECRET

ORIGINATOR'S SIGNATURE

[Handwritten signature]

[Handwritten mark]

50X1

50X1

50X1

50X1

200100 01 342

200130Z ZFF-4 ZPO [redacted]

50X1

BT

XXXXX

OPCEN 565 [redacted]

50X1

TOP SECRET 200125Z CITE [redacted]

50X1

IMMEDIATE ADIC INFO PRIORITY [redacted]

50X1

REALM 101T

A. BX 6705

B. TANKER MISSION SUPPORT TAKE-OFF REPORT (AR TOP OFF)

C. [redacted]

ILLEGIB

D. 20/0105Z

E. NONE

TOP SECRET

BT

NNNN

Play A

TOP SECRET

OTIS

50X1

IMMEDIATE ADIO

INFO PRIORITY

50X1

REEM 101T

~~BY~~ BX 6705

B. TANKER MISSION SUPPORT TAKE-OFF REPORT

(AR TOP OFF)

50X1

O.

B. 20/0105 2

B. ~~GROUND SPARE LAUNCHER, BUT WITH PRIMARY CREW~~
~~CALL SIGN REMAINS SAME~~
NONE

END OF MESSAGE

TOP SECRET

ORIGINATOR'S SIGNATURE

[Redacted Signature Box]

50X1

A

21 00z

200127Z ZFF-1 ZPO [redacted]

50X1

BT
XXXXX

OPCEN 563 [redacted]

50X1

TOP SECRET 200124Z CITE [redacted]

50X1

IMMEDIATE ADIC INFO PRIORITY [redacted]

50X1

REALM 101T

A. EX6705

B. TANKER MISSION SUPPORT TAKE-OFF REPORT (AR 2)

C. [redacted]

50X1

D. 20/0057Z

E. NONE

TOP SECRET

BT

NNNN

[Handwritten signature]

~~TOP SECRET~~

~~SECRET~~

50X1

~~DISSEMINATE ADIC~~

~~INFO PRIORITY~~

50X1

REF ID: A6705

1. ~~6705~~

2. TANKER MISSION SUPPORT TANKER REPORT (NOV 2)

50X1

3. [Redacted]

4. 20/0057

5. NONE

END OF MESSAGE

~~TOP SECRET~~

50X1

ORIGINATOR'S SIGNATURE

[Redacted Signature Box]

A.

(23)

200124Z ZFF-4 ZPO [redacted]

BT
XXXXX
OPCEN 562 [redacted]

21 27z

50X1

50X1

TOP SECRET 200122Z CITE [redacted]
IMMEDIATE ADIC INFO PRIORITY [redacted]

50X1

50X1

- REALM 101T
- A. BX 6705
- B. TANKER MISSION SUPPORT TAKE-OFF REPORT (AR NBR 2)
- C. [redacted]
- D. 20/0056Z
- E. NONE

50X1

TOP SECRET
BT

NNNN

George *A*

TOP SECRET

OFF

50X1

IMMEDIATE ADIC

EXT PRIORITY

50X1

NRLEN 101T

A. ~~8x~~ 6705

B. TANKER MISSION SUPPORT TAKE-OFF REPORT (NOV 2)

50X1

B. 20/0056 2

B. NONE

END OF MESSAGE

TOP SECRET

50X1

ORIGINATOR'S SIGNATURE

200128Z ZFF-4 ZPO [redacted]

50X1

BT

XXXXX

OPCEN 564 [redacted]

50X1

T O P S E C R E T 200125Z CITE [redacted]

50X1

IMMEDIATE ADIC INFO PRIORITY [redacted]

50X1

REALM 101T

A. BX 6705

B. TANKER MISSION SUPPORT TAKE-OFF REPORT (AR NBR 2)

50X1

C. [redacted]

D. 20/0055Z

E. GROUND SPARE LAUNCHED, BUT WITH PRIMARY CREW [redacted]
CALL SIGNS WILL REMAIN THE SAME. OTHER AIRCRAFT IS NOW GROUND
SPARE AND IN-COMMISSION.

50X1

T O P S E C R E T

BT

NNNN

~~TOP SECRET~~

~~SECRET~~

50X1

~~IMMEDIATE ACTION~~

~~INFO PRIORITY~~

50X1

REMARK 101T

~~BX~~ 6705

B. TOWER MISSION SUPPORT TAKE-OFF REPORT (000_2)

C. [REDACTED]

50X1

D. 20/0055 2

~~GROUND~~ GROUND SPARE LAUNCHED, BUT WITH
PRIMARY CREW [REDACTED]. CALL SIGNS WILL
REMAIN THE SAME. OTHER AIRCRAFT
IS NOW GROUND SPARE AND IN-COMMISSIONAL.
END OF MESSAGE

~~TOP SECRET~~

50X1

ORIGINATOR'S SIGNATURE

[REDACTED SIGNATURE]

A

(E)

192359Z ZFF-4

BT

XXXXX

OPCEN 557

S E C R E T 192352Z CITE

50X1

IMMEDIATE ADIC

REALM 35

OXCART BLACKSHIELD MATERIEL

A. SPECIAL FUEL TEST REPORT (2 1/2 HOUR PRE-FLIGHT) BX 5735

B. 071 0655L/20

089 0705L/20

504 0715L/20

099 0725L/20

088 0800L/20

094 0810L/20

513 0820L/20

520 0830L/20

103 0840L/20

125 0850L/20

C. FUEL TESTED IN PARA B QUALIFIED IAW SECTION VII TEST CRITERIA.

S E C R E T

BT

NNNN

200008Z
BT
XXXXX
OPCEN 559

T O P S E C R E T 200006Z CITE
IMMEDIATE ADIC
OXCART BLACKSHIELD OPS MAT
REALM X

50X1

A. BX-6705
B. REF ADIC 2903
C. IN REFERENCE TO YOUR QUESTION ON TANKER ACFT TAIL NBR 522.
THIS ACFT AS WELL AS TAIL NBR 099 ARE GROUND SPARES FOR THIS
MSN AND NOT LISTED IN THE 87T.
T O P S E C R E T
BT

50X1

NNNN

N *A*

XERO COPY

XERO COPY

XERO COPY

XERO COPY

TOP SECRET

IMMEDIATE

TO: ADIC

CITE:

50X1

OX CART/BLACKSHIELD/OPS/MAT

REALM X

A. BX-6705
(Msn #)

50X1

B. (Text of msg) REF. ADIC 2903

C. IN REFERENCE TO YOUR QUESTION ON TANKER ACFT TAIL # 520. THIS ACFT AS WELL AS TAIL # 099 ARE GROUND SPARES FOR THIS MSN AND NOT LISTED IN THE 87T.

Handwritten mark

50X1

(Releaser & DTG)

20/0855L

TOP SECRET

Handwritten mark

(16Jun67)

20008Z ZFF 3
BT
XXXXX
OPCEN 558 CABLE 927

T O P S E C R E T 200006Z CITE
IMMEDIATE ADIC INFO IMMEDIATE CABLE
REALM 20

50X1

- OXCART/BLACK SHIELD/OPS
- A. AIRFIELD STATUS REPORT (DATE/TIME(L)/TIME(Z) 20/0900L-19/2400Z
 - B. (1) RWY 05L 23R 12,000 AVAILABLE FOR T.O. & LANDING, RWY NORMAL.
(2) RWY 05R 23L CLZD FOR CONSTRUCTION NEXT 60-90 DAYS.
(THIS IS SECONDARY RWY).
(3) TAXIWAY AND HARD STAND CLOSURES IN CONJUNCTION WITH
(2) ABOVE DO NOT AFFECT OUR OPERATION.
 - C. IN COMM.
(1) VOICE AVAILABLE.
 - D. IN COMM.
 - E. IN COMM.
 - F. IN COMM.
 - G. IN COMM.
 - H. IN COMM.
 - I. NONE.
 - J. NONE.
- T O P S E C R E T
BT

A

N

NNNN

T O P S E C R E T

CITE:

50X1

TO: IMMEDIATE ADIC INFO: IMMEDIATE CABLE

REALM 20
OXCART/BLACK SHIELD/OP:

A. AIRFIELD STATUS REPORT (DATE/TIME(L)/TIME(Z)) 20/0700-19/2400Z

B. (1) RWY 05L 23R 12,000 AVAILABLE FOR T.O. & LANDING,
RWY NORMAL.

(2) RWY 05R 23L CLZD FOR CONSTRUCTION NEXT 60 - 90
DAYS. (THIS IS SECONDARY RWY).

(3) TAXIWAY AND HARD STAND CLOSURES IN CONJUNCTION
WITH (2) ABOVE DO NOT AFFECT OUR OPERATION.

C. IN COMM.

(1) VOICE AVAILABLE.

D. IN COMM.

E. IN COMM.

F. IN COMM.

G. IN COMM.

H. IN COMM

I. NONE

J. NONE

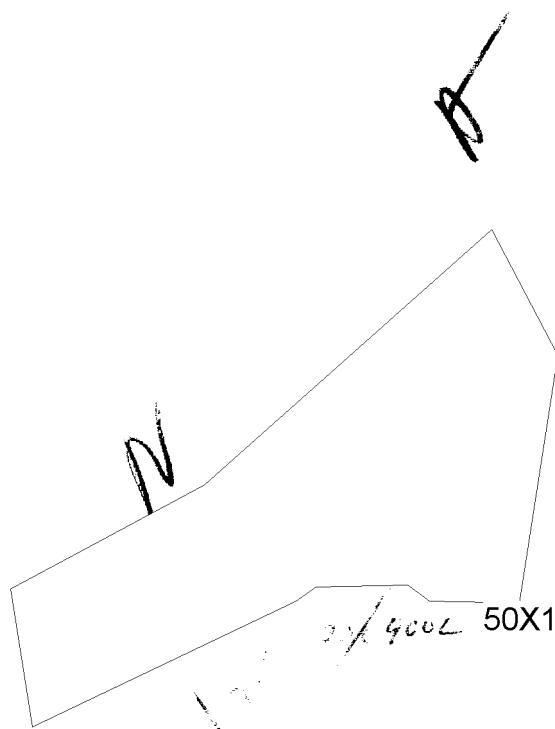

19 JUN 72 20 56z

192353Z ZFF-4 ZFC [redacted]
BT
XXXXX
OPCEN 556 [redacted]

50X1

50X1

TOP SECRET 192347Z [redacted]
IMMEDIATE ADIC INFO PRIORITY [redacted]

50X1

50X1

REALM 10IT
A. BXGT03
B. TANKER MISSION SUPPORT TANKER [redacted] (SEE NBR 1)
C. [redacted]
D. 19/2337Z
E. NONE
TOP SECRET
BT

50X1

WNNN

N
R

~~TCP SECRET~~

DATE

50X1

IMMEDIATE ADIS

INFO PRIORITY

50X1

REALM 101R

A. ~~SECRET~~ BX6505

B. TANKER MISSION SUPPORT TAKE-OFF REPORT (REV L)

50X1

C.

D.

2337 Z

E.

NONE

END OF MESSAGE

TCP SECRET

50X1

ORIGINATOR'S SIGNATURE

Handwritten mark

N
FS
(2)

192349Z ZFF-1 ZPO [redacted]

50X1

BT
XXXXX

OPCEN 554 [redacted]

50X1

T O P S E C R E T 192347Z CITE [redacted]

50X1

IMMEDIATE ADIC INFO PRIORITY [redacted]

50X1

REALM 101T

A. BX6705

B. TANKER MISSION SUPPORT TAKE-OFF REPORT (AR 1)

C. [redacted]

50X1

D. 19/2336Z

E. NONE

T O P S E C R E T

BT

N
H

~~TOP SECRET~~

CITE

50X1

~~IMMEDIATE ADIC~~

INFO PRIORITY

50X1

REALM 101T

A. ~~REF~~ BX 6705

B. TANKER MISSION SUPPORT TAKE-OFF REPORT (ADV 1)

C.

50X1

D. 19/2336 8

E. NONE

END OF MESSAGE

TOP SECRET

50X1

ORIGINATOR'S SIGNATURE

[Handwritten mark]

[Handwritten marks]

1974

Z

192354Z ZFF-4 ZPO [redacted]

50X1

BT

XXXXX

OPCEN 555 [redacted]

50X1

TOP SECRET 192347Z CITE [redacted]

50X1

IMMEDIATE ADIC INFO PRIORITY [redacted]

50X1

REALM 10IT

A. BX6795

B. TANKER MISSION SUPPORT TAKE-OFF [redacted] (SAR REF ID)

50X1

C. [redacted]

D. 1972335Z

E. NONE

TOP SECRET

BT

N

B

TOP SECRET

OITE

50X1

IMMEDIATE ADIG

INFO PRIORITY

50X1

REALM IOIT

A. ~~SECRET~~ BX 6705

B. TANKER MISSION SUPPORT TAKE-OFF REPORT (APP 1)

C. [Redacted]

50X1

D. 19/2335 Z

E. NONE

END OF MESSAGE

TOP SECRET

50X1

ORIGINATOR'S SIGNATURE

[Redacted Signature Box]



Handwritten initials 'R' or 'A' in the bottom right area.

Handwritten 'N' and a circled '25' in the bottom right corner.

Page Denied

XERO COPY

XERO COPY

XERO COPY

XERO COPY

TOP SECRET

IMMEDIATE

TO: ADIC

CITE:



50X1

OXCART/BLACKSHIELD/OPS

REALM X

A. BX-6705
(Msn #)

B. ALL COORDINATION COMPLETED

A



50X1

(Releaser & DTG)

20/4815 L.

P

W

TOP SECRET

(16Jun67)

Page Denied

T O P S E C R E T 192201Z CITE



9 JUN 67 22 04z

50X1

IMMEDIATE ADIC WECEN

OXCAPT BLACK SHIELD WX OPS

REALM 236 (D)

A. BX 6705

B. 20/0220Z TO 0815Z JUNE 67

C. RODN, ROAH: NO SIG CHANGE

RPMK: NO SIG CHANGE

RCGM: NO SIG CHANGE

VTBI: NO SIG CHANGE

VTBU: NO SIG CHANGE

T O P S E C R E T

BT

Page Denied

✓ T O P S E C R E T 192153Z CITE
IMMEDIATE ADIC INFO IMMEDIATE WECEN
✶ OXCART BLACK SHIELD WX OPS
REALM 243
A. BX 6705
B. 19/2100Z
C. RODN 174V BRKN 45 OVC 4F 2303 CIG 3V5
ROAH M5 BRKN 20 BRKN HI BRKN 5F 2105 5 BRKN V SCD
RCGM 50 SCTD HI BRKN 7 2104
VTBI HI THN SCTD 7 1504
VTBU 90 SCTD HI THN BRKN 12 3103 OCNL DSNT LTG N-NE
RPMK 35 SCTD E65 BRKN HI BRKN 12 CALM

T O P S E C R E T
BT

50X1

9 JUN 67 21 59z

TOP SECRET

ACTION: IMMEDIATE

INFO: IMMEDIATE

FROM:

50X1

TO: ADIC

INFO: WECEN

OXCAR/BLACK SHIELD/WX/OPS
REALM 243

A. BX 6705

B. 19/2146Z

C. RUDN 17AV BRKN 45 OVC 4F 2308 CIG 3VS

ROAH MS BRKN 20 BRKN HI BRKN 5F 2106

5 BRKN V SCTD

RCGM 50 ● SCTD HI BRKN 7 2109

VTBI HI THN SCTD 7 1509

VTBU 90 SCTD HI THN BRKN 12 3103 CCNL

DSNT LTG N-NE

RPMK 35 SCTD 215 BRKN HI BRKN 12 CALM

END OF MESSAGE

50X1

#21

19/2146Z
DATE/TIME

TOP SECRET

T O P S E C R E T 191635Z CITE

50X1

IMMEDIATE ADIC
OXCART BLACKSHIELD OPS
REALM 86

19 JUN 67 16 39z

- A. BX-6705
- B. PRE-SORTIE REPORT
- C. 129 131

50X1

D.

E. ~~20/0220Z~~ 20/0320Z

F. PRIMARY TYPE I CAMERA, BIRDWATCHER, PIN PEG, BIG BLAST, BLUE
DOG II, SIP.

SPARE SAME AS PRIMARY

G. NO EFFECT

H. NONE

T O P S E C R E T

BT

TOP SECRET

IMMEDIATE

TO: ADIC

CITE:

50X1

OXCART/BLACKSHIELD/OPS

REALM 86

A. BX-6705
(Msn #)

B. PRE-SORTIE REPORT

C. 129 131
(Prim Acft) (Spare Acft)

D.
(Prim Pilot) (Spare Pilot)

50X1

E. 20/0220Z 20/0320Z
(Planned ATD Prim) (Planned ATD Spare)

F. PRIMARY TYPE I CAMERA, BIRDWATCHER, PIN PEG, BIR
(Type special equip on Acft)

BLAST, BLUE DOG II, SIP.

SPARE SAME AS PRIMARY

G. NO EFFECT
(Expected effect of lcl WX on ability to launch)

H. (Comments)

NONE

(Releaser & DTG)

50X1

A

W

TOP SECRET

(16Jun67)



TOP SECRET 191607Z CITE

IMMEDIATE ADIC, WECEN

OXCAR/ BLACK SHIELD/ WX/ OPS

REALM 236 (C)

A. BX6705

B. 20/0220Z TO 0815Z JUNE 67

C. RODN, ROAH: 12 SCTD 30 SCTD 150 BRKN 230 BRKN 10 230/08G12

RW- FAP 04-08Z, NIL RPMK: 40 SCTD 300 SCTD 15 99/07 CB VCNTY 00-08Z

RCG, 25 SCTD 300 BRKN 7 250/12020, NIL

VTBI: 30 SCTD 100 SCTD 300 BRKN 7 152/25, NIL

VTBU: 20 SCTD 120 SCTD 300 BRKN 15 132/17 CB VCNTY 02-08Z, NIL

TOP SECRET

BT

NNNN

ACTION: IMMEDIATE

FROM:

TO: ADIC, WECEN

CXCHRT/BLACK (SAY) / W/UPS

REALM 236 (C)

A. BX6705

B. 20/02002 TO 0115Z JUNE 67

C. ROOM, WDAH: 10 SCTD 0 SCTD 0 BRN

230 BRN 10 100 G10 RW 10 100 100 100

REMARK 40 SCTD 300 SCTD 15 100 100

CG VENTY 02 01 01 01

RCGM: 25 R 00 100 100 100 100 100 100 100

VTBE 30 SCTD 100 SCTD 300 BRN 100 100 100

VTBU 20 SCTD 100 SCTD 300 BRN 100 100 100

CG VENTY 02 01 01 01

END OF MESSAGE . COORD:

20/0105 L

DATE/TIME

TOP SECRET

19

50X1

50X1

JOINT MESSAGEFORM			
SECURITY CLASSIFICATION			
TOP SECRET			
TYPE MSG	BOOK	MULTI	SINGLE
PRECEDENCE			
ACTION	IMMEDIATE		
INFO	IMMEDIATE		
			DTG

FROM:

TO: ADIC

SPECIAL INSTRUCTIONS 50X1
 1-CMDR
 1-DCS
 1-SIGCEN
 1-SECUR

REALM 92

A. BX 6705

B. EMERGENCY Seat Pack Message

C. Pilots Emergency Seat Pack Contents are IAW Standard

Survival Kit Contents dated 15 May 1967, Except for the following Additions:

Kit, Medical

- | | |
|----------------------|---------------------|
| Chloroquine | Nupercaine Ointment |
| Actified | Dramamine |
| Tetracycline | Dilaudid |
| Otrivin | Codeine |
| Cortisporin Ointment | Lomotil |
| A-Fil | |

Batteries(Size AA) For use in ASR 100, & can be used in Penlight Flashlight, 12 Each

Gill, net 1 Each

DATE	TIME
20	
MONTH	YEAR
June	67
PAGE NO.	NO. OF PAGES
1	2

DRAFTER	TYPED NAME AND TITLE	PHONE	RELEASESER	50X1	
				Chief, Security	50X1
SECURITY CLASSIFICATION			REGRADING INSTRUCTIONS		

JOINT MESSAGEFORM - CONTINUATION SHEET

SECURITY CLASSIFICATION

TOP SECRET

FROM:

Socks, White, Wool & Nylon	1 Pair
Shoes, Tennis(Converse Brand)	1 Pair
Distillation kit, Desert	1 Each
Additions to Aux Survival Kit:	
Sand paper, 400 Grit, Weather Dry (Used in place of Emry Paper)	1/2 Sheet
Compass, Button	
Chloroquine-Primaquine	4 Each
Deletions to Aux Survival Kit:	
Boric Acid Ointment, Tube	1 Each
D. None	

END OF MESSAGE

SYMBOL	PAGE NR	NR OF PAGES	SECURITY CLASSIFICATION	INITIALS

DD FORM 173-1
MAY 55

19/0859Z ZPO [redacted]

50X1

BT

YKXXX

OPCEN 536 [redacted]

50X1

SECRET 190852Z CITE [redacted]

50X1

PRIORITY ADIC INFO [redacted]

50X1

REALM 30

AS OF 1700 HOURS, 19 JUN

A. SUPPORT AIRCRAFT STATUS

B. F-101B - 340 - IN - NA - 100 - USES FOR

SECRET

BT

Handwritten signature and initials
A 17

NNNN

19/09 15Z

BT
XXXXX
OPCEN 538



SECRET 190905Z CITE

PRIORITY ADIC INFO

REALM 21

A. OPERATIONAL CAPABILITY REPORT

B. 127

51:26 - 215 B. 61:47 - 221 (6) 375:5 (7) WAITING SHIPMENT OF
PLASTIC RUDDER

129

(1) OR (2) NA (3) NA (4) 22:45/THIRD (5) A. 51:50 - 225 B.
60:29 - 227 (6) 300:32 (7) NA

131

(1) OR (2) NA (3) NA (4) 25:12/THIRD (5) A. 50:22 - 210
B. 39:39 - 230 (6) 210:54 (7) NA

C. 3/3

D. SORC - 127

(1)-1 (2)-1 (3)-1 (4)-1 (5)-1 (6)-1 (7)-2 (8)-3 (9)-3
(10)-3 (11)-2 (12)-2 (13)-3 (14)-3 (15)-1 (16)-1 (17)-3
(18)-1 (19)-3

SORC - 129

(1)-1 (2)-1 (3)-1 (4)-1 (5)-1 (6)-1 (7)-2 (8)-3 (9)-3
(10)-3 (11)-2 (12)-2 (13)-3 (14)-3 (15)-2 (16)-2 (17)-1
(18)-1 (19)-3

SORC - 131

(1)-1 (2)-1 (3)-1 (4)-1 (5)-1 (6)-1 (7)-2 (8)-3 (9)-3
(10)-3 (11)-2 (12)-2 (13)-3 (14)-3 (15)-2 (16)-2 (17)-3
(18)-1 (19)-3

E. NA

F. CRITICAL ASSETS

(1) 3/3 (2) 2/2 (3) 4/4 (4) 4/4 (5) 4/3 (6) 4/4
(7) 4/4 (8) 4/4 (9) 5/5 (10) 4/4

SECRET

BT

50X1
50X1
50X1

Handwritten signature and number 16

NNNN

13 Jun 67 01 5 :
15129
07

117
190857Z ZFF-1
BT
XXXXX
OPCEN 537

SECRET 190854Z CITE
IMMEDIATE ADIC
REALM 35

50X1

OXCART/BLACKSHIELD/MATERIEL
A. SPECIAL FUEL TEST REPORT (POST REFUELS) EX 6785

- B. 103 1030L/19
- 039 1225L/19
- 504 1300L/19
- 071 1320L/19
- 125 1450L/19
- 513 1530L/19
- 099 1530L/19
- 094 1700L/19
- 088 1730L/19

C. FUEL TESTED IN PARA B QUALIFIED IAW SECTION VII
TEST CRITERIA.

SECRET
BT

[Handwritten signatures and initials]

JOINT MESSAGEFORM		RESERVED FOR COMMUNICATION CENTER	
SECURITY CLASSIFICATION SECRET			
PRECEDENCE IMMEDIATE			
ACTION IMMEDIATE		DTG	
INFO		SPECIAL INSTRUCTIONS	
FROM: [Redacted]		50X1 1 SIG CTR 1 ONDR 1 OP 1 DCM 1 POL 	
TO: ADIC			
HEALM 35			
OKCANT/BLACKSHIELD/MATERIEL			
A. SPECIAL FUEL TEST REPORT (POST RESULTS) BE 6705			
B. 103 1030L/19			
089 1225L/19			
504 1300L/19			
071 1320L/19			
125 1450L/19			
513 1530L/19			
099 1530L/19			
094 1700L/19			
088 1730L/19			
C. FUEL TESTED IN PARA B QUALIFIED IAW SECTION VII			
TEST CRITERIA			
END OF MESSAGE		DATE	
		TIME	
		MONTH	
		YEAR	
		PAGE NO.	
		NO. OF PAGES	
D R A F T E R	TYPED NAME AND TITLE	PHONE	SIGNATURE
			TYPED (or stamped) NAME AND TITLE
SECURITY CLASSIFICATION SECRET		REGRADING INSTRUCTIONS	

DD FORM 173 NOV 63

REPLACES EDITION OF 1 MAY 55 WHICH MAY BE USED

GPO : 1964 O-734-401

Page Denied

Next 3 Page(s) In Document Denied

190725Z ZFF-1 ZPO [redacted]

BT

XXXXX

OPCEN 528 [redacted]

13 JUN 67 21z

50X1

50X1

T O P S E C R E T 190723Z CITE [redacted]

IMMEDIATE ADIC INFO PRIORITY [redacted]

REALM 87T

50X1

50X1

A. BX 6705

B. TANKER PRE-SORTIE REPORT (AF NBR 0)

C. PRIMARY 20/0055Z 20/0655Z

PRIMARY 20/0056Z 20/1030Z

SPARE 20/0057Z 20/1035Z

D. PRIMARY 58094, [redacted]

PRIMARY 591513, [redacted]

SPARE 58088, [redacted]

50X1

E. 20/0542Z

F. 48731 LBS

G. 70000 LBS

H. NONE

I. [redacted] LANDING [redacted] FOR FUEL.

50X1

T O P S E C R E T

BT

50X1

NNNN

TOP SECRET _____ CITE

50X1

IMMEDIATE ADIO INFO PRIORITY

50X1

REALM 8TT

A. ^{BX} ~~SM~~ 6705 _____

B. TANKER PRE-SORTIE REPORT (AD# 2 _____)

C. PRIMARY 20/0055 _____ 20/0655 _____

PRIMARY 20/0056 _____ 20/1030 _____

SPARE 20/0057 _____ 20/1035 _____

D. PRIMARY 58094 _____

PRIMARY 591513 _____

SPARE 58088 _____



50X1

E. _____ 20/0542 Z

F. _____ 48731 lbs

G. _____ 70000 lbs

H. None

A

I. _____

LANDING ~~FUEL~~ FOR FUEL

50X1

50X1

END OF MESSAGE

TOP SECRET

ORIGINATOR'S SIGNATURE



50X1

(12)

W

TOP SECRET _____ CITE _____

50X1

IMMEDIATE ADIC INFO PRIORITY

50X1

REALM 87T

A. ^{Bx} ~~100~~ 6705 _____

B. TANKER PRE-SORTIE REPORT (ADIC _____)

C. PRIMARY 19/2335 _____ Z _____ 20/0535 _____ Z

50X1

PRIMARY 19/2336 _____ Z _____ 20/0540 _____ Z

SPARE 19/2337 _____ Z _____ 20/0545 _____ Z

D. PRIMARY 58071 _____

PRIMARY 58089 _____

SPARE 591504 _____

E. _____ 20/0420 Z _____

F. _____ 59810 lbs _____

G. _____ 70000 lbs _____

H. None

I. Due to PF-1A restriction ~~and~~ landing U-Tapao for fuel prior to return to Kadena, LANDING ~~FAKILL~~ AT

50X1

50X1

50X1

50X1

END OF MESSAGE

TOP SECRET

ORIGINATOR'S SIGNATURE

(Handwritten mark)

(Handwritten mark)

19/0727Z ZFF-1 ZPO [redacted]

BT

XXXXXX

OPCEN 529 [redacted]

TOP SECRET 190726Z CITE [redacted]

IMMEDIATE ADIC INFO PRIORITY [redacted]

REALM 877

- A. BX6705
- B. TANKER PRE-SORTIE REPORT (AN REP 104 OFF)
- C. PRIMARY: 28/0105Z 28/0505Z
- SPARE 28/0106Z 28/0510Z
- D. PRIMARY 58105, [redacted]
- SPARE 58125, [redacted]
- E. 28/0248Z
- F. 33732 LBS
- G. 76000 LBS
- H. NONE
- I. NONE

TOP SECRET
BT

NNNN

50X1

50X1

50X1

50X1

50X1

50X1

TOP SECRET

CITE

[Redacted]

INFO: ~~IMMEDIATE~~ PRIORITY

[Redacted]

IMMEDIATE ADIO

[Redacted]

REALM 87T

A. ~~EX~~ Bx 6705

B. TANKER PRE-SORTIE REPORT. (AR # ^{Top} Off)

C. PRIMARY: 20/0105 Z 20/0505 Z
SPARE

20/0106 Z 20/0510 Z

D. PRIMARY 58103 ,

[Redacted]

SPARE 58125 ,

E. 20/0242 Z

F. 33732 lbs

G. 70000 lbs

H. None

I. None

END OF MESSAGE

TOP SECRET

A

ORIGINATOR'S SIGNATURE

[Redacted]

10

[Handwritten mark]

50X1

JOINT MESSAGEFORM			
SECURITY CLASSIFICATION			
SECRET			
IMMEDIATE			
PRECEDENCE			
ACTION			
IMMEDIATE			
INFO		DTG	
FROM: [REDACTED]		SPECIAL INSTRUCTIONS	
TO: ADIC		1 SIG CTR 1 ONDR 1 OP 1 DOP 1 POL	
REALM 35		A. SPECIAL FUEL TEST REPORT (POST FLIGHT) B. 099 1300L/19 C. FUEL TESTED IN PARA B QUALIFIED IAW SECTION VII TEST CRITERIA END OF MESSAGE	
TYPED NAME AND TITLE		PHONE	SIGNATURE
D R A F T E R			
SECURITY CLASSIFICATION		REGRADING INSTRUCTIONS	
SECRET			

50X1

ILLEGIB

50X1

A

DATE	TIME
MONTH	YEAR
PAGE NO.	NO. OF PAGES

288

190408Z

190408Z ZFF-1
BT
XXXXX
OPCEN 520

SECRET 190405Z CITE
IMMEDIATE ADIC
REALM 35

50X1

- A. SPECIAL FUEL TEST REPORT (POST FLIGHT)
- B. 099 1300L/19
- C. FUEL TESTED IN PARA B QUALIFIED IAW SECTION VII TEST CRITERIA.

SECRET
BT

9 ✓ A

190718Z ZFF-1 ZPO [redacted]

BT
XXXXX
OPCEN 527 [redacted]

50X1

T O P S E C R E T 190715Z CITE [redacted]
IMMEDIATE ADIC INFO PRIORITY [redacted]
REALM 87T

50X1

50X1

- A. BX 6705
- B. TANKER PRE-SORTIE REPORT (AR NFR 1)
- C. PRIMARY 19/2335Z 20/0535Z
PRIMARY 19/2336Z 20/0540Z
SPARE 19/2337Z 20/0545Z

- D. PRIMARY 58071, [redacted]
PRIMARY 58089, [redacted]
SPARE 591504, [redacted]

50X1

- E. 20/2420Z
- F. 59810 LBS
- G. 70000 LBS
- H. NONE

50X1

50X1

I. DUE TO PF-1A RESTRICTION, [redacted] WILL LAND AT
UTAPAO FOR FUEL. [redacted] WILL LAND AT [redacted] FOR SAME REASON.
ALL WILL RETURN ASAP TO [redacted]

50X1

50X1

T O P S E C R E T
BT

(11)

A.

NNNN

Page Denied

Next 12 Page(s) In Document Denied

190012Z ZFF-1 ZPO WECEN

BT

XXXXX

OPCEN 501 WECEN 110

T O P S E C R E T 190010Z CITE



50X1

IMMEDIATE ADIC, WECEN

OXCART/BLACKSHIELD/WX/OPS

REALM X

A. TO FACILITATE SUPPORT OF CO-LOCATED TANKER FORCE, COPIES OF R-237 ARE GIVEN TO ITFC FOR PRELIM PLANNING AND ARE THE PRIMARY SOURCE OF INFO FOR FLIGHT FOLDERS AND BRIEFING SLIDES DELIVERED TWO HOURS PRIOR TO EACH TANKER LAUNCH. AFTER OFF-LOAD, KC-135'S ALWAYS RETURN AT APPROX FL430 AND REQUIRE RETURN WINDS AND TEMPS AT THIS LEVEL. THE RCM DOES NOT CALL FOR FL430 RETURN WINDS & TEMPS, NOR FOR ENROUTE WEATHER. LOW AND HIGH LEVEL HWD'S VALID 0000Z AND 1200Z ARE AVAILABLE VIA FAX FROM FUCHU WX CENTRAL, BUT SIGNIFICANT ENROUTE WX WOULD BE HELPFUL IN R-237.

B. REQUEST FL430 ROUTE WINDS AND TEMPS FOR RETURN FROM ALL A/C'S AND SIGNIFICANT ENROUTE WEATHER BE ADDED TO NEXT AND ALL FUTURE R-237 MESSAGES.

T O P S E C R E T

BT

Handwritten marks: a circled '7', 'W', 'A', and 'N/A'.

NNNN

Page Denied

261

10 JUN 67 22 48z

182243Z ZFF-1
BT
XXXXX
OPCEN 494

T O P S E C R E T 182239Z CITE
IMMEDIATE ADIC
OXCART BLACK SHIELD/OPS
REALM X
REF: ADIC 2784
A. BX6705.
B. REF PARA H: PRIMARY ACFT IS 129. CAPABLE OF
HANDLING TYPE I CAMERA, WILL USE. BACKUP ACFT 131, WILL ALSO
USE TYPE I.
T O P S E C R E T
BT

50X1

NNNN

Handwritten signature and initials:
A
W
N
P
N

JOINT MESSAGEFORM

SECURITY CLASSIFICATION

TOP SECRET **SECRET**

18 JUN 67 22 39z

BOOK MULTIPLE SINGLE
TYPE MSG

PRECEDENCE

10000

50X1

ACTION IMMEDIATE

INFO

DTG

FROM:

TO: ADIC

OX CART BLACK SHIELD/OPS

REALM X

REF: ADIC 2784

A. BX6705.

B. REF PARA H: PRIMARY ACFT IS 129. CAPABLE OF HANDLING TYPE I CAMERA, WILL USE. BACKUP ACFT 131, WILL ALSO USE TYPE I.

E.O.M.

SPECIAL INSTRUCTIONS

- 1- SigGen
- 1- Comdr
- ② DCO

[Handwritten mark]

50X1

DATE	TIME
19	0735L
MONTH	YEAR
JUN	67
PAGE NO.	NO. OF PAGES
1	1

DRAFTER	TYPED NAME AND TITLE	PHONE	RELEASER	SIGNATURE

SECURITY CLASSIFICATION

TOP SECRET

REGARDING INSTRUCTIONS

50X1

DD FORM 173 1 NOV. 63

REPLACES EDITION OF 15 MAY 58 WHICH MAY BE USED

☆ GPO 1966-206-852

267

18 JUN 67 23 09z

182305Z ZFF-1
BT
XXXXX
OPCEN 499

TOP SECRET 182304Z CITE
IMMEDIATE ADIC
OXCART/BLACKSHIELD/OPS
REALM X

50X1

1. SYSTEM VI WILL NOT BE USED. REASON - WE HAVE NOT RECEIVED THE RECORDING BELTS.

2. CORRECTION TO REALM 57: PAR C SHOULD READ 18/2055Z.

TOP SECRET
BT

NNNN

[Handwritten signature and initials]

265

10 17 12 58z

182253Z ZFF-1
BT
XXXXX
OPCEN 497

T O P S E C R E T 182247Z CITE [redacted]
IMMEDIATE ADIC
OXCART/BLACKSHIELD/OPS
REALM 57

50X1

- A. BX6705
- B. MISSION ALERT CONFIRMATION MSG
- C. 18/2055Z

D. [redacted]

50X1

E. 129 131
T O P S E C R E T
BT

NNNN

Handwritten signatures and initials:
N [unclear] (4)
W

XERO COPY

XERO COPY

XERO COPY

XERO COPY

TOP SECRET

IMMEDIATE

TO: ADIC

CITE:

50X1

OX CART/BLACKSHIELD/OPS

REALM 57

A. BX 6705
(Msn #)

B. MISSION ALERT CONFIRMATION MSG

C. 18/2055 Z
(Date/Time (Z) alert recd @ CP)

D.

(Prim Pilot)

(Sec Pilot)

(Other Pilot Alerted)

50X1

E. 129
(Prim Acft)

131
(Spare Acft)

F. (Comments)

(Releaser & DTG)

19/0745L

50X1

TOP SECRET

(16Jun67)

Confirmation

RGRG QRV
QSL 077

PGRG SHOOT

JAA078
IMMEDIATE
DET 4/078
FM: DET 4 313ADIV
TO: AFSSO 313ADIV
T O P S E C R E T BYEMAN CHANNEL
GREY STAR 06-36
THIS IS A GREY STAR INTENTION ALERT MSG
A. BX 6705
B. 20/0020Z
C. REQUEST UHF & HF TACTICAL CALLSIGN OF PRIMARY AND SPARE WX
SCOUT FOR EACH REFUELING AREA.
D. TOP OFF REFUELING:
(1) SUPE HIT
(2) (ARCT) 20/0242Z
E. FIRST REFUELING:
(1) STEEL BRIDGE
(2) (ARCT) 20/0420Z
F. SECOND REFUELING:
(1) STEEL BRIDGE
(2) (ARCT) 20/0540Z
G. THIRD REFUELING:
(1) N/A
(2) (ARCT) N/A
H. REQUEST CONFIRMATION
I. REQUEST RETRANSMISSION OF THIS MSG (ROUND ROBIN).
BT

A

E

W

NNNN

18 MAR 68 06z

078

IMMEDIATE

DET 4/078

FM: DET 4 313ADIV

TO: AFSSO 313ADIV

T O P S E C R E T BYEMAN CHANNEL

GREY STAR 06-36

THIS IS A GREY STAR INTENTION ALERT MSG

- A. BX 6705
 - B. 20/0020Z
 - C. REQUEST UHF & HF TACTICAL CALLSIGN OF PRIMARY AND SPARE WX SCOUT FOR EACH REFUELING AREA.
 - D. TOP OFF REFUELING:
 - (1) SURE HIT
 - (2) (ARCT) 20/0242Z
 - E. FIRST REFUELING:
 - (1) STEEL BRIDGE
 - (2) (ARCT) 20/0420Z
 - F. SECOND REFUELING:
 - (1) STEEL BRIDGE
 - (2) (ARCT) 20/0540Z
 - G. THIRD REFUELING:
 - (1) N/A
 - (2) (ARCT) N/A
 - H. REQUEST CONFIRMATION
 - I. REQUEST RETRANSMISSION OF THIS MSG (ROUND ROBIN).
- BT

Handwritten mark

Handwritten mark

XERO COPY

XERO COPY

XERO COPY

TOP SECRET

IMMEDIATE

FROM: DET 4 313ADIV

TO: AFSSO 313ADIV

TOP SECRET ~~SECRET~~ BYEMAN CHANNEL

GREY STAR 06-36
(Msg #)

THIS IS A GREY STAR INTENTION ALERT MSG

A. (Msn #) BX 6705

B. 20/0020 Z
(Date/Time first WX Scout report required (MLT H-2))

C. REQUEST UHF & HF TACTICAL CALLSIGN OF PRIMARY AND SPARE WX SCOUT FOR EACH REFUELING AREA.

D. TOP OFF REFUELING:

(1) SURE HIT
(Air Refueling Track, unclass nickname)

(2) (ARCT) 20/0242 Z

E. FIRST REFUELING:

(1) STEEL BRIDGE
(Air Refueling Track, unclass nickname)

(2) (ARCT) 20/0420 Z

F. SECOND REFUELING:

(1) STEEL BRIDGE
(Air Refueling Track, unclass nickname)

(2) (ARCT) 20/0540 Z

G. THIRD REFUELING:

(1) N/A
(Air Refueling Track, unclass nickname)

(2) (ARCT) N/A

H. REQUEST CONFIRMATION.

I. REQUEST RETRANSMISSION OF THIS MSG (ROUND ROBIN).



(Releaser & DTG)

Det 4, 313th ADiv Format #1 16Jun67

19/0745L

50X1

TOP SECRET

1322 132

132224Z ZFF-1 ZPO

[Redacted]

50X1

BT
XXXXX

OPCEN 493

[Redacted]

50X1

S E C R E T 132223Z CITE

[Redacted]

50X1

IMMEDIATE ADIC INFO PRIORITY

[Redacted]

50X1

REALM 53T

- A. BX6705
- B. TANKER SUPPORT CONFIRMATION MESSAGE
- C. SUPPORT AVAILAELE
- D. N/A
- E. N/A
- F. N/A
- G. N/A
- H. NONE

S E C R E T
BT

2

Handwritten mark

Handwritten mark

NNNN

SECRET

CITE



50X1

IMMEDIATE ADIC INFO PRIORITY



50X1

REALM 58T

A. BX6705

B. TANKER SUPPORT CONFIRMATION MESSAGE

C. SUPPORT AVAILABLE

D. N/A

E. N/A

F. N/A

G. N/A

H. NONB

A



50X1

1/2225-2

N/A



W

264 375

18 22 57z

182252Z ZFF-3
BT
XXXXX
OPCEN 496 CABLE 399

T O P S E C R E T 182251Z CITE [redacted]
IMMEDIATE ADIC INFO IMMEDIATE CABLE
OXCART/BLACKSHIELD/OPS
REALM 20

50X1

- A. AIRFIELD STATUS REPORT 19/0900L-18/2400Z
 - B. (1) RWY 05L 23R 12,100 AVAILABLE FOR T.O. & LANDING,
RWY DRY.
 - (2) RWY 05R 23L CLZD FOR CONSTRUCTION NEXT 60-90
DAYS. (THIS IS SECONDARY RWY).
 - (3) TAXIWAY AND HARD STAND CLOSURES IN CONJUNCTION
WITH (2) ABOVE DO NOT AFFECT OUR OPERATION.
 - C. INCOMM
(1) VOICE AVAILABLE
 - D. INCOMM
 - E. INCOMM
 - F. INCOMM
 - G. INCOMM
 - H. INCOMM
 - I. NONE
 - J. NONE
- T O P S E C R E T
BT

0

Handwritten mark

Handwritten mark

TOP SECRET

CITE:

50X1

TO: IMMEDIATE ADIC INFO: IMMEDIATE CABLE
OX CART BLACKSHIELD/OPS
REALM 20

A. AIRFIELD STATUS REPORT (DATE/TIME (L)/TIME (Z)) *19/0900L-18/2400Z*

B. (1) RWY 05L 23R 12,100 AVAILABLE FOR T.O. & LANDING

RWY *DRY*.

(2) RWY 05R 23L CLSD FOR CONSTRUCTION NEXT 60 - 90
DAYS. (THIS IS SECONDARY RWY).

(3) TAXIWAY AND HARD STAND CLOSURES IN CONJUNCTION
WITH (2) ABOVE DO NOT AFFECT OUR OPERATION.

C. IN COMM.

(1) VOICE AVAILABLE.

D. IN COMM.

E. IN COMM.

F. IN COMM.

G. IN COMM.

H. IN COMM.

I. NONE.

J.

(Large handwritten circle)

NHC

Page Denied

JOINT MESSAGEFORM

SECURITY CLASSIFICATION
TOP SECRET

20 JUN 67 14 37z

TYPE MSG	BOOK	MULTI	SINGLE
----------	------	-------	--------

PRECEDENCE

ACTION **IMMEDIATE**

INFO **IMMEDIATE**

DTG

FROM:

COLOR

TO:

ADLC

REALM 113

- A. BX6705
- B. INS TAPE REPORT
- C. INS OLO
- D. DATA LINK
- E. 20/1400Z
- F. 1/10/67
- G. 670620-015140
- H. DATA GOOD

END OF MESSAGE

SPECIAL INSTRUCTIONS

- 1 SIG GEN
- 1 JONDR
- 1 DCM
- 1 INS
- 1 DCO

50X1

DATE	TIME
MONTH 20	YEAR
PAGE NO. JUN	NO. OF PAGES 67

DRAFTER	TYPED NAME AND TITLE	PHONE

RELEASEE	SIGNATURE
	TYPED (or stamped) NAME AND TITLE

ILLEGIB

SECURITY CLASSIFICATION
TOP SECRET

REGARDING INSTRUCTIONS

50X1

DD FORM 173 1 NOV 63

REPLACES EDITION OF 1 MAY 55 WHICH MAY BE USED

☆ GPO 1966-206-552

TOP SECRET [REDACTED]

50X1
50X1

IMMEDIATE ADIC. [REDACTED]

REACH 121

A. BK5705

B. INS TAPE EVALUATION REPORT

C. INS 610

D. 20/0531 Z

E. 1. SATISFACTORY

2. SATISFACTORY

3. SATISFACTORY

4. SATISFACTORY

5. LEAST SIGNIFICANT DIGIT MISSING AT ELAPSED TIMES
17326 AND 17394

6. SATISFACTORY

7. SATISFACTORY

8. SATISFACTORY

9. SATISFACTORY

10. SATISFACTORY

INS

F. EXTRA DATA LINE BETWEEN ELAPSED TIMES, 11420 AND 11458.

SIX DATA LINES MISSING BETWEEN ELAPSED TIMES 11420 AND 11441.

ONE GARBLED DATA LINE BETWEEN ELAPSED TIMES 11326 AND 11398.

EVALUATION PERTAINS TO CAMERA OPERATION ONLY. ERRORS ABOVE CAN
BE SALVAGED.

TOP SECRET

(DCM)

Page Denied

Next 1 Page(s) In Document Denied

11 04 1974 67

* * * * *							* A N S W E R S *		R E M A R K S
GROUND SPEED	SUN ALT	HAZE FCTR	V/H	TYPE II V/H CODE	SLIT OPEN	TYPE I EXP			
1801	82	1	3.877	IOII0	1	11		THIS IS A <u>BX6705 MESSAGE</u>	
1801	82	1	3.813	IOI00	1	11		<u>REALM 81D BACKUP AIRCRAFT</u>	
1801	84	1	3.789	IOI00	1	11		<u>TYPE 1 PACKAGE</u>	
1802	85	1	3.777	IOI00	1	11		TRUE ALTITUDES ARE USED	
1802	86	1	3.762	IO0II	1	11		<u>CANNED ROUTE EIGHT</u>	
1804	88	1	3.767	IO0II	1	11		STBY 2 1652N 11046E	
1806	87	1	3.809	IOI00	1	11		CAM ON 1505N 10729E	
1821	86	1	3.831	IOI0I	1	11		STBY 2 2018N 10133E	
1737	73	1	3.877	IOII0	2	11		CAM ON 1602N 10432E	
1737	72	1	3.846	IOI0I	2	11		STBY 2 2007N 10152E	
1750	71	1	3.855	IOI0I	2	11		CAM ON 1618N 10428E	
1804	70	1	3.958	II000	2	11		STBY 2 1832N 11137E	
1806	70	1	3.938	IOIII	2	11			
1808	71	1	3.919	IOIII	2	11			
1808	72	1	3.902	IOII0	2	11			
1802	72	1	3.934	IOIII	2	11			
1816	72	1	3.970	II000	2	11			
1736	56	1	3.875	IOII0	2	11			
1736	56	1	3.840	IOI0I	2	11			
1736	54	1	3.814	IOI00	2	11			
1737	53	1	3.798	IOI00	2	11			

1100 (9 Jun 67)

* * * * *							* ANSWERS *			
GROUND SPEED	SUN ALT	HAZE FCTR	V/H	TYPE II		TYPE I EXP	REMARKS			
				V/H CODE	SLIT OPEN					
1801	72	1	3.877	IOIIO	2	11	THIS IS A BX6705 MESSAGE			
1801	73	1	3.813	IOI00	2	11	<u>REALM 810 PRIMARY AIRCRAFT</u>			
1801	73	1	3.789	IOI00	2	11	<u>TYPE 1 PACKAGE</u>			
1802	74	1	3.777	IOI00	2	11	TRUE ALTITUDES ^{ARE} USED			
1802	74	1	3.762	IO0II	2	11	CANNED ROUTE EIGHT			
1804	75	1	3.767	IO0II	2	11	STBY 2 1652N 11406E ✓			
1806	75	1	3.809	IOI00	2	11	CAM ON 1505N 10729E) 1			
1821	74	1	3.841	IOIOI	2	11	STBY 2 2018N 10133E)			
1737	83	1	3.877	IOIIO	1	11	CAM ON 1602N 10432E) 2			
1737	83	1	3.846	IOIOI	1	11	STBY 2 2007N 10152E)			
1750	84	1	3.855	IOIOI	1	11	CAM ON 1618N 10428E) 3			
1804	84	1	3.958	II000	1	11	STBY 2 1832N 11137E)			
1806	84	1	3.938	IOIII	1	11				
1808	85	1	3.919	IOIII	1	11				
1808	85	1	3.902	IOIIO	1	11				
1802	86	1	3.934	IOIII	1	11				
1816	85	1	3.970	II000	1	11				
1736	69	1	3.875	IOIIO	2	11				
1736	67	1	3.840	IOIOI	2	11				
1736	65	1	3.814	IOI00	2	11				
1737	63	1	3.798	IOI00	2	11				

Page Denied

Next 1 Page(s) In Document Denied

DCM 24 HOUR AIRCRAFT GENERATION CHECKLIST

PRE TAKE-OFF

H-HOUR 1120/20 June

48224

*ITEMS TO BE CALLED TO C.P.

Rev 5/31/67

	1	2	3	4	5	6	*7	8	9	10	*11	12
	DCM Alert Mtn to start generation	Cmdrs Initial Briefing	Select Acft & Assign Package	Mtn to Secure Nitrogen Oxygen	POL to Secure fuel trucks	DCM Mtng with Contract Pers	Start Mission Acft Preflt	Receive Fuel Load fm Flt Plan	Pers Eqp P/U LOX fm POL	REALM 63 to EWS & SIP	TEB, LOX & Refuel #1 & #2	ARC-50 Codes to DCM
-HOUR	H-24 H-23:30	H-23:30	H-23:30 H-22:30	H-23:00	H-23:00	H-22:30	H-22:30	H-22:30	H-22:00	H-22:00	H-22:00 H-19:00	H-22:00
LOCAL TIME	1120 1150	1150 —	1150 1250	1220 —	1220 —	1250 —	1250 —	1250 —	1320	1320	1320	1320
#1 ACTUAL TIME 129	1120 1135	1150 —	1150 1215	1000 1000	1220 —	1220 —	1100 —	1100 —	1445 —	0900 —	1300 1430	1320 —
#2 ACTUAL TIME 131	1120 1135	1150 —	1150 1215	1000 —	1220 —	1220 —	1100 —	1100 —	1445 —	0900 —	1300 1430	1320 —
	13	14	15	*16	*17	18	19	*20	*21	22	23	24
	COMMC & IFF Preflt	Install Instr	Select Recovery Crew & give to DCM	INS Preflt	EWS Preflt	Pkg Data avail fm Flt Plan	INS Data avail fm Flt Plan	Pkg Loaded in Acft #1 & #2	SIP Install checked out & Beacon Check	Pkg Data Loaded	INS Data Prepared for Loading	POL Send Realm 35
-HOUR	H-22:00 H-18:00	H-20:00 H-18:00	H-20:00 H-16:00	H-18:00 H-16:00	H-16:00 H-13:00	H-13:45	H-12:45 H-12:00	H-13:00 H-8:30	H-11:00 H-8:30	H-11:00 H-8:30	H-11:00 H-6:00	H-10:45
LOCAL TIME	1320 1720	1520 1720	1520 1920	1720 1920	1920 2220	2135 —	2235 2320	2220 0250	0020 0250	0020 0250	0020 0520	0035 —
#1 ACTUAL TIME 129	1330 1600	1625 1630	1500 1700	0630 0930	1545 1605	1330 —	1300 —	2115 —	2215 2320	2100 2200	1300 1500	0745 <i>Completed</i>
#2 ACTUAL TIME 131	1400 1730	1630 1645	1500 1700	0630 0630	1620 1635	1330 —	1300 —	2115 0020	2225 2320	2100 2200	1350 1500	

Declassified in Part - Sanitized Copy Approved for Release 2013/06/12 : CIA-RDP69B00041R000200040001-2

FORM 24 H-102 AIRCRAFT GENERATION CHECKLIST

PRE TAKE-OFF

H-HOUR 1120/20 June

* INDICATES ITEMS TO BE CALLED TO C.F.

Rev 5/31/67

	25	26	27	*28	29	*30	31	32	33	34	35	*36
	Crew Chief Standby Acft	Mtn call Security to Sterilize Cockpit	Nitrogen Top Off	Pers Eqp Loaded	Acft Status Brief CC, INS, EW3, Pkg & DCM	Start INS warmup	Pkg II Preheat	Pkg I Helium Purge Q-Bay	View- finder Loaded with film	INS Data Tape Loading	Engineer Cock Acft	Engine Start, Power Switch & Towout #1
H-HOUR	H-4:00 H-3:30	H-4:00 H-3:30	H-4:00 H-3:30	H-3:30 H-3:00	H-3:30	H-3:30 2 H-2:30	H-3:30	H-2:00	H-2:00 H-1:30	H-2:00 H-1:30	H-1:30 H-1:00	H-1:30 - 30 H-1:15
LOCAL TIME	0720 1120	0720 0750	0720 0750	0750 0820	0750	0750	0750	0920	0920	0920	0950	1045
#1 ACTUAL TIME	0720 129	0720 0725	0720 0740	0750 0805	0750	0800		0920	0950	0950	1020	1105
#2 ACTUAL TIME	0720 131	0745 0800	0800 0830	0745 0800	0750	0850			0850 0925	0930	0930	1106

	38											
	Taxi & Taxi off	Monk Rec & gather Rec Gear										
H-HOUR	H-1:15 H-1:00	H-1:00										
LOCAL TIME	1105 1120	1120 1220										
# ACTUAL TIME	1106 129	1120										
ACTUAL TIME	131											

	39	40	41	42	43	44	45	46	47	48	49	50
	Standby Spare Acft & Start Engines	Unload Pkg & INS from Spare Acft	Spare Acft Declas	Remove View-finder Film & Map fm spare	Land & Cool Mission Acft	Secure Mission Acft & Service Engine Oil	SCDM Tape Removed & Given to SIP	Remove View-finder Film & Maps	Remove Blue Dog Tape	Acft Mtn Debrief	Remove Instr Pkg	Move Acft In Hangar
H-HOUR	H+:25	H+:30 H+:2:30	H+2:30	H+2:30	L+:30	L+:30 L+1:15	L+:30 L+1:15	L+:30 L+1:15	L+:30 L+1:15	L+:45	L+1:00	L+1:15 L+1:30
LOCAL TIME	1145	1150 1350	1350	1350	1650	1650 1835	1650 1835	1650 1835	1650 1835	1705	1720	1835 1830
#1 ACTUAL TIME	129	1500				1730 1810	1700 1720	1735 1740	1745 1800	1730	1740	1730 1735
#2 ACTUAL TIME												

	51	52	53	54	55	56	57	58	59	60	61
	Unload Pkg & Prepare TAKE	INS Erase Data fm Computer	SCDM Data to Flt Plan for Realm 113	SIP Data to OPS	Declass Mission Acft	Pkg "TAKE" to Security	Fkg Submit Realm 117 to DCM	Blue Dog Tape to Security	INS/SCDM Tab Run to Security	INS Send SCDM Tape to Security	INS Submit Realm 127 to DCM
H-HOUR	L+2:30 L+3:30	L+2:00 L+3:00	L+3:30	L+3:30 L+4:15	L+4:00	L+5:00	L+5:00	L+5:00	L+5:00	L+9:00	L+20:00
LOCAL TIME	1850 1950	1820 1920	1950	1950 2035	2020	2120	2120	2120	2120	2120	1220/2120
#1 ACTUAL TIME	1760 1820	1830	1830		1830	1900	1845				
#2 ACTUAL TIME											

Declassified in Part - Sanitized Copy Approved for Release 2013/06/12 : CIA-RDP69B00041R000200040001-2

ILLEGIB

Page Denied

Next 2 Page(s) In Document Denied

Declassified in Part - Sanitized Copy Approved for Release 2013/06/12 : CIA-RDP69B00041R000200040001-2

TOP SECRET

FROM: Mission Coordinator

19 JUNE 1967

SUBJECT: Mission Alert Notification

TO: (See below)

Request your attendance at the Commander's Briefing to be held in the Operations Briefing Room on 19 JUNE 1967 at 1150 L. The briefing concerns the following:

1. Mission Code Name and Number: RX 5705
2. Date/Time of Launch (H-Hour): 20 / 0320 Z / 1120 L.
3. Ground Spare (H+1:00): 20 / 0320 Z / 1220 L.
4. General Area of Operation: N/R
5. Bases: Takeoff KADENA, Staging -, Landing KADENA.
6. Equipment required: TYPE I, BWI, PIN PEG, BIG BLAST, BLUE DOG II, SIP ON SYSTEM 6
7. Ground Spare Requirements: SAME AS Pri. where POSSIBLE.
8. Special Instructions/Comments: LAUNCH BACK UP AT 1220h IF Pri ABORTS. BY CANCELED MISSION #8

FOR THE COMMANDER

Mission Coordinator

Office	Time (L)	Recipient	Office	Time (L)	Recipient
CMDR	_____	_____	DCOL	_____	_____
DCO	_____	_____	DCOC/MC	<u>0720</u>	<u>Rnd</u>
DCM	_____	_____	DCOMI	_____	_____
DCS	_____	_____	DCOW	_____	_____
SECUR	_____	_____	COMMO	_____	_____
FLT SURG	_____	_____	AECS	_____	(Notify Only)
DCOM	_____	_____	TTPG(SAC)	_____	(Notify Only)

JOINT MESSAGEFORM

SECURITY CLASSIFICATION

SECRET

TYPE: [] [] MULTI [] SINGLE

RECORDING

ACTION: **IMMEDIATE**

INFO

18 11Z

DTG

FROM:

TO:

ADIO

REALM 35

OXGART/BLACKSHIELD/MATERIEL

- A. SPECIAL FUEL TEST REPORT (POST REFUEL) BX 6705
 - B. 520 0645L/20
 - C. FUEL TESTED IN PARA B QUALIFIED IAW SECTION VII
- TEST CRITERIA

KIND OF MESSAGE

SPECIAL INSTRUCTIONS 50X1
50X1

- 1 SIG OTR
- 1 ONDR
- 1 GP
- 1 DCM
- 1 PCL

DATE	TIME
MONTH	YEAR
PAGE NO.	NO. OF PAGES

DRAFTER	TYPED NAME AND TITLE	PHONE	SIGNATURE	50X1
			TYPED <i>[Signature]</i>	
SECURITY CLASSIFICATION			REGRADING INSTRUCTIONS	

SECRET

DD FORM 17, NOV 55

Page Denied

Next 1 Page(s) In Document Denied

RESERVED FOR COMMUNICATION CENTER

JOINT MESSAGEFORM

SECRET
MULTI SINGLE
IMMEDIATE

ACTION **IMMEDIATE**
INFO

DTG

FROM: [Redacted]
TO: **ADIG**

SPECIAL INSTRUCTION: 50X1

- 1 SIG OTR
- 1 OADR
- 1 OP
- 1 DCM
- 1 POL

REALM 35

OXCART/BLACKSHIELD/MATERIEL

A. SPECIAL FUEL TEST REPORT (2 1/2 HOUR PRE-FLIGHT) BX 6705

B. 071 0655L/20

089 0705L/20

504 0715L/20

099 0725L/20

088 0800L/20

094 0810L/20

515 0820L/20

520 0830L/20

105 0840L/20

125 0850L/20

C. FUEL TESTED IN PARA B QUALIFIED IAW SECTION VII

TEST CRITERIA

END OF MESSAGE

DATE	TIME
MONTH	YEAR
PAGE NO.	NO. OF PAGES

ILLEGIB

D R A F T E R	TYPED NAME AND TITLE	PHONE	R E L E A S E R	SIGNATURE
				TYPE
SECURITY CLASSIFICATION		REGARDING INSTRUCTIONS		

SECRET

DD FORM 1 NOV 68 173

Page Denied

JOINT MESSAGEFORM

SECURITY CLASSIFICATION

SECRET

20 JUN 67 16 14z

BOOK MULTI SINGLE

PRECEDENCE

IMMEDIATE

15235

ACTION

IMMEDIATE

DTG

INFO

FROM:

[Redacted]

SPECIAL INSTRUCTIONS

50X1

TO:

ADIC

REALM 35

OXCART/BLACKSHIELD/MATERIEL

- 1 SIG CTR
- 1 CMDR
- 1 CP
- 1 DCM
- 1 POL

A. SPECIAL FUEL TEST REPORT (POST FLIGHT) BX 6 705

B. 103 1415L/20

125 1430L/20

513 2020L/20

071 2030L/20

089 2200L/20

504 2240L/20

520 2300L/20

C. FUEL TESTED IN PARA B QUALIFIED IAW SECTION VII

TEST CRITERIA

END OF MESSAGE

DATE	TIME
MONTH	YEAR
PAGE NO.	NO. OF PAGES

D R A F T E R	TYPE NAME AND TITLE	PHONE	R E L E A S E R	SIGNATURE
				TYP
SECURITY CLASSIFICATION		REGRA		

SECRET

DD FORM 1 NOV. 63 173

REPLACES EDITION OF 1 MAY 58 WHICH MAY BE USED

☆ GPO 1965-761-933

JOINT MESSAGEFORM

SECURITY CLASSIFICATION

TOP SECRET

20 JUN 67 14 37z

TYPE MSG	BOOK	MULTI	SINGLE
----------	------	-------	--------

PRECEDENCE

ACTION	IMMEDIATE
--------	------------------

INFO	IMMEDIATE
------	------------------

DTG

15000

FROM:

TO:

ADLC

REALM 113

- A. BX6705
- B. INS TAPE REPORT
- C. INS OLO
- D. DATA LINK
- E. ~~20/1400Z~~ 11/1400Z
- F. 21/1200Z
- G. 670620-015140
- H. DATA GOOD

END OF MESSAGE

SPECIAL INSTRUCTIONS

- 1 SIG GEN
- 1 COMDR
- ① DCM
- 1 INS
- 1 DCO

50X1
50X1

gwr

DATE	TIME
20	
MONTH	YEAR
JUN	67
PAGE NO.	NO. OF PAGES

TYPED NAME AND TITLE

PHONE

RELEAS

50X1

TOP SECRET

RM 7. 63 173

REPLACES EDITION OF 1 MAY 55 WHICH MAY BE USED.

☆ GPO 1966-206-552

JOINT MESSAGEFORM			
<div style="display: flex; justify-content: space-between;"> SECURITY CLASSIFICATION 20 JUN 67 10 28z </div> <h1 style="text-align: center; opacity: 0.5;">TOP SECRET</h1>			
TYPE MSG	BOOK	MULTI	SINGLE
15300			
PRECEDENCE			
ACTION		IMMEDIATE	
INFO		IMMEDIATE	
FROM:			DTG
TO: ADIC			INFO: CABLE
REAM 117 A. BX6705 B. XXXXXXXXXX TYPE I CAMERA CONFIGURATION REPORT C. I-G/JUNE 20/129 D. 700/700 E. 700/700 F. 3403/2177/267 2/15 - 11 - 6 G. 5.6/YELLOW, 12 H. 72/74 83/85 69/60 I. 0340Z/0402Z 0448Z/0526Z 0639Z/0651Z J. ENTIRE ROUTE/300/39 IN CLOUD K. NA L. AS BRIEFED - MOSTLY CLEAR			SPECIAL INSTRUCTIONS 1 SIG CEN 1 COMDR ① DCM 1 P.E. 1 DCO
TYPED NAME AND TITLE		PHONE	RELEASER
<div style="display: flex; justify-content: space-between;"> SECURITY CLASSIFICATION REGRADING INSTRUCTIONS </div> <h1 style="text-align: center; opacity: 0.5;">TOP SECRET</h1>			

50X1

50X1

50X1

50X1

50X1

50X1

MESSAGEFORM - CONTINUATION SHEET

SECURITY CLASSIFICATION

~~SECRET~~
~~TOP SECRET~~

FROM:

[Empty box for FROM information]

M.M. BS SECURITY 201000Z

50X1

N. SUCCESSFUL MISSION. DELAY RELAY PERMITTED THREE RECYCLES AT START OF INTIAL RUN.

END OF MESSAGE

SYMBOL

PAGE NR

NR OF PAGES

SECURITY CLASSIFICATION

INITIALS

~~SECRET~~

FORM 1 MAY 55 173-1

NNNNOFKHCZCZC066

356/192304Z

BT

XXXXX



50X1

S E C R E T 192300Z CITE ADIC 2903

19 JUN 67 23 19z

PRIORITY 

50X1

REALM X (BX6705)

20265

REF:  (REALM 35)

50X1

1. REQUEST CONFIRMATION OF ACFT NBR CONTAINED IN REF.
2. REALM 87T'S DO NOT SHOW A TANKER ACFT WITH TAIL NBR

520 PARTICIPATING IN BX6705.

S E C R E T

BT

Handwritten signature and notes:
 ACTION
 DUM

JOINT MESSAGEFORM

SECURITY CLASSIFICATION
SECRET

BOOK MULTI SINGLE
IMMEDIATE

ACTION
INFO **IMMEDIATE** DTG

FROM: []

TO: **ADIC**

REALM 35

OXCART/BLACKSHIELD/MATERIEL

A. SPECIAL FUEL TEST REPORT (POST FLIGHT) BX 6 705

B. 103 1415L/20

125 1430L/20

513 2020L/20

071 2030L/20

089 2200L/20

504 2240L/20

520 2300L/20

C. FUEL TESTED IN PARA B QUALIFIED IAW SECTION VII

TEST CRITERIA

END OF MESSAGE

SPECIAL INSTRU**50X1**:

- 1 SIG CTR**
- 1 COMR**
- 1 CP**
- 1 DCN**
- 1 POL**

DATE	TIME
MONTH	YEAR
PAGE NO.	NO. OF PAGES

DRAFTER

TYPED NAME AND TITLE

PHONE

SECURITY CLASSIFICATION
SECRET

RELEASER

SIGNATURE

50X1

JOINT MESSAGEFORM

SECURITY CLASSIFICATION

SECRET

21 JUN 67 05 59z

TYPE MSG	BOOK	MULTI	SINGLE
----------	------	-------	--------

PRECEDENCE

ACTION **PRIORITY**

INFO

DTG

FROM: [Redacted]

TO: ADIC [Redacted]

SPECIAL INSTRUCTIONS 50X1

- 1 SIG CEN
- 1 COMER 50X1
- 1 ~~DCM~~
- 1 DCO
- 1 INS

REAIM 127

- A. BX 6705
- B. FINAL FIELD EVALUATION OF INS DATA
- C. INS 010
- D. LINE 031, DECK OFF FOR 09 MINUTES. NO EXPLANATION
- LINE 0384, DECK TURN OFF ~~XXXXXXXXXX~~ PLAN LENT
- LINE 0394, TRANSIENT, NO SCAN WAS MISSED
- LINE 0464, TRANSIENT, TWO SCANS MISSED
- LINE 0467, DECK OFF FOR 1 HOUR 30 MINUTES. NO EXPLANATION.

END OF MESSAGE

DATE	TIME
21	
MONTH	YEAR
JUN	
PAGE NO.	NO. OF PAGES
	67

DRAFTER	TYPED NAME AND TITLE	PHONE	RELEASEE	SIGNATURE
	[Redacted]	[Redacted]		[Redacted]

50X11

SECURITY CLASSIFICATION

SECRET

REGRADE INSTRUCTIONS

DD FORM 173

OFFICE EDITION OF 1 MAY 55 WHICH MAY BE USED

☆ GPO 1966-206-552

Page Denied

Next 3 Page(s) In Document Denied

KADENA

TACAN/ILS-RWY 05-1

100 JAL 1457 (USAF)

KADENA AB KADENA, OKINAWA I., RYUKYU ISLANDS

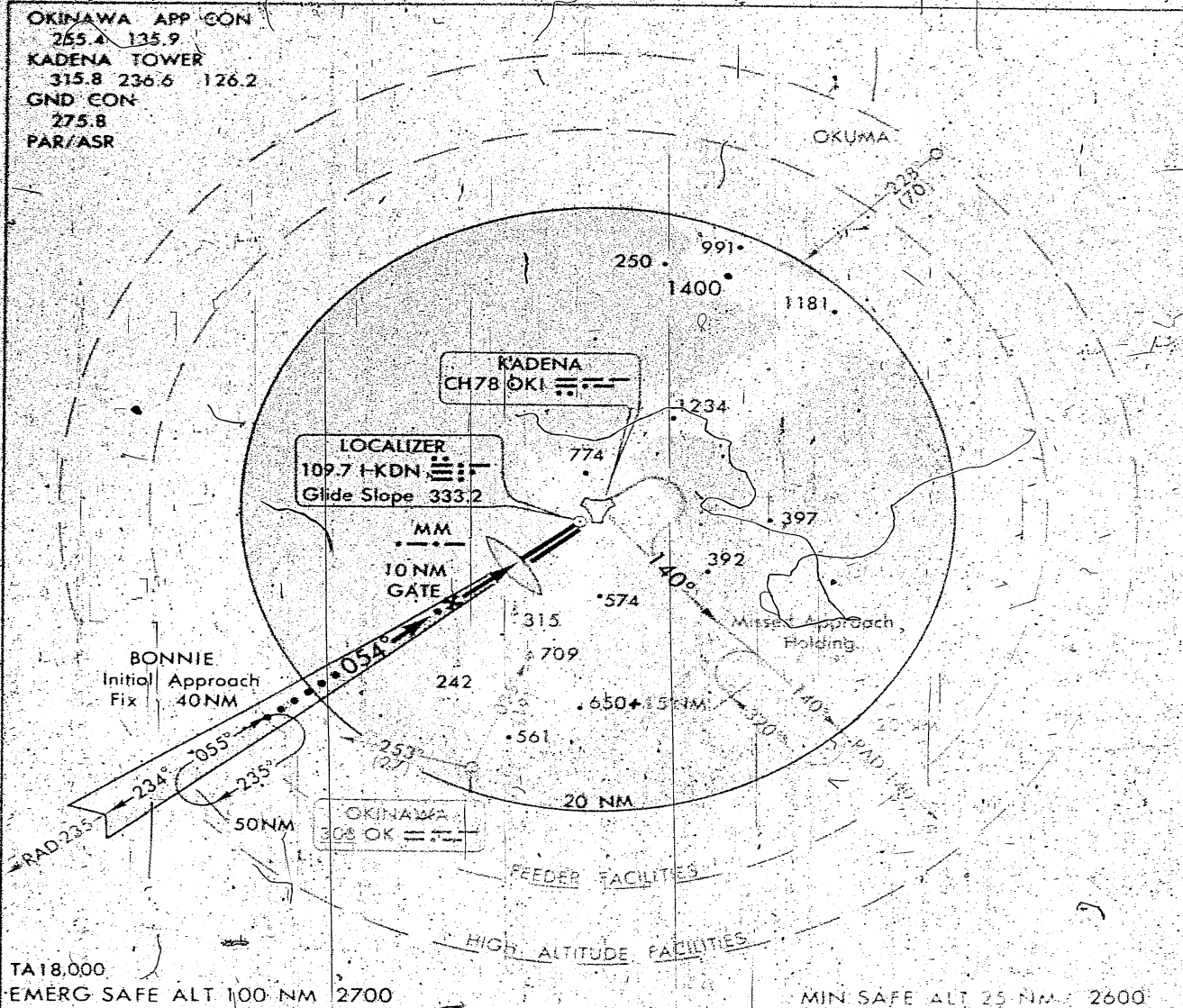

TA 18,000
EMERG SAFE ALT 100 NM 2700

MIN SAFE ALT 25 NM 2600

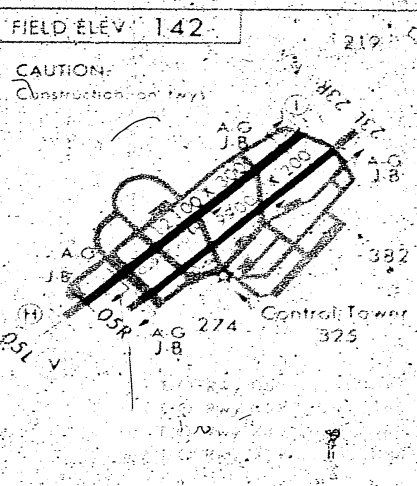
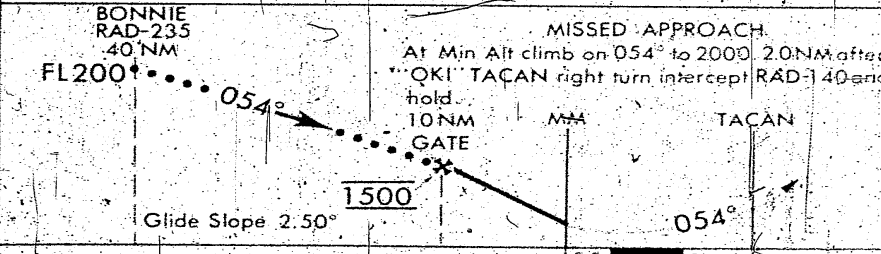

LANDING MINIMA	
Str-in-ILS	342 MSL : 200-1/2 or RVR 24
Str-in-TACAN	400 MSL : 300-1
* Circling	800 MSL : 700-1

*Circling to-East only.

TACAN/ILS-RWY 05-1

26°21'N-127°46'E

KADENA, OKINAWA I., RYUKYU ISLANDS
KADENA AB

KADENA

KADENA

TACAN/ILS-RWY 05-2

JAL 1457 (USAF)

KADENA, OKINAWA

KADENA AB

OKINAWA APP CON
1255.4 135.9
KADENA TOWER
315.8 236.6 126.2
GND CON
275.8
PAR/ASR

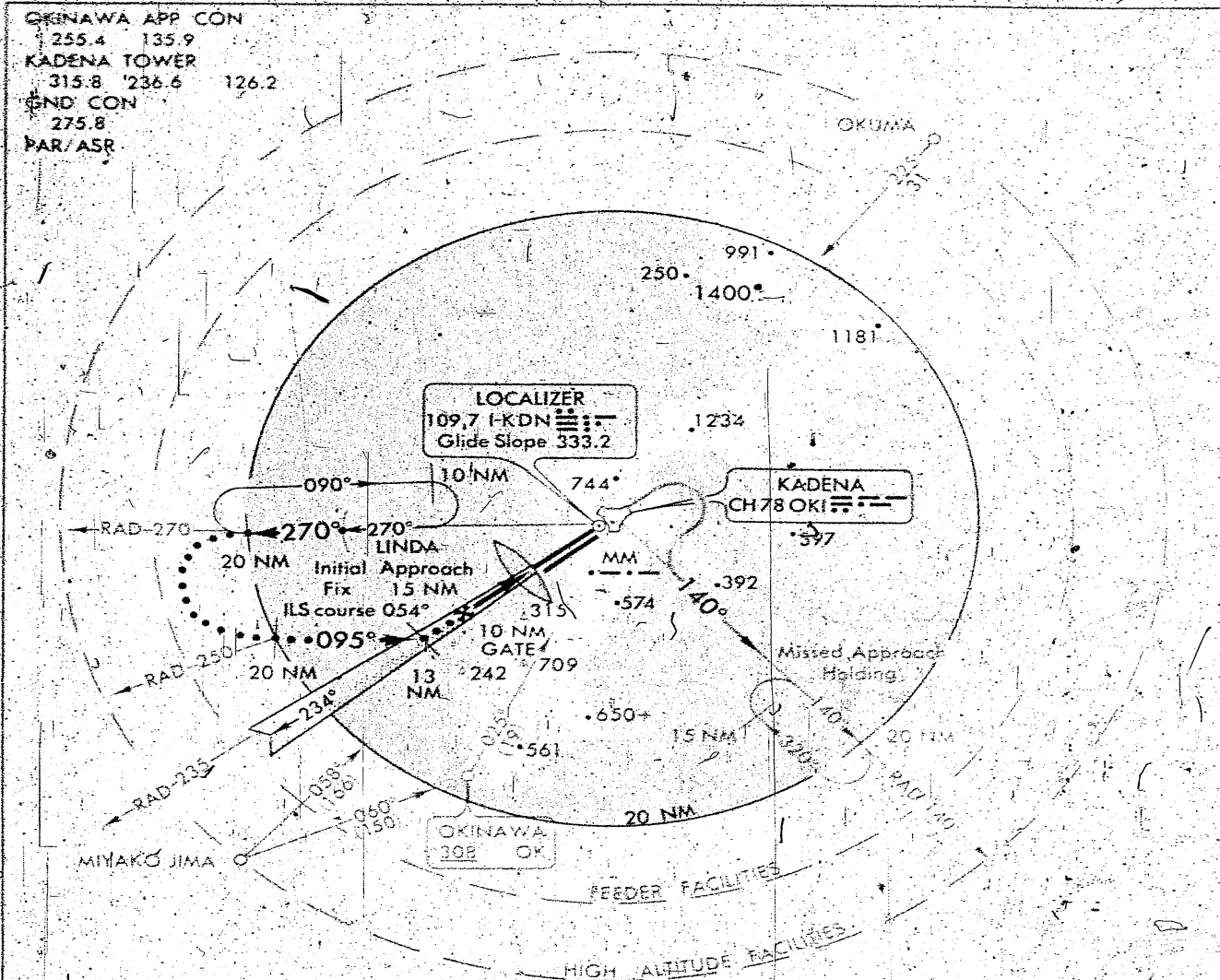

TA 18,000
EMERG SAFE ALT 100 NM 2700

MAIN SAFE ALT 25 NM 2600

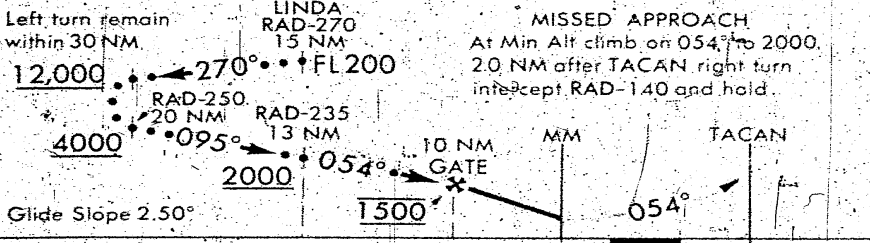

FIELD ELEV 142

CAUTION
Construction on taxiway

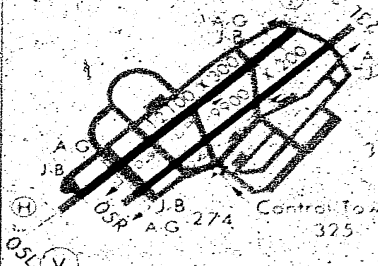

LANDING MINIMA	
Str-in-ILS	342 MSL : 200-1 or RVR 24
Str-in-TACAN	400 MSL : 300-1
* Circling	800 MSL : 700-1

* Circling to East only.

TACAN/ILS-RWY 05-2

26°21'N-127°46'E

KADENA, OKINAWA

KADENA AB

KADENA

KADENA

TACAN-RWY 23-3

JAL 1457 (USAF)

KADENA, OKINAWA

KADENA AB
RYUKYU ISLANDS

OKINAWA APP CON
255.4 135.9
KADENA TOWER
315.8 236.6 126.2
GND CON
275.8
PAR/ASR

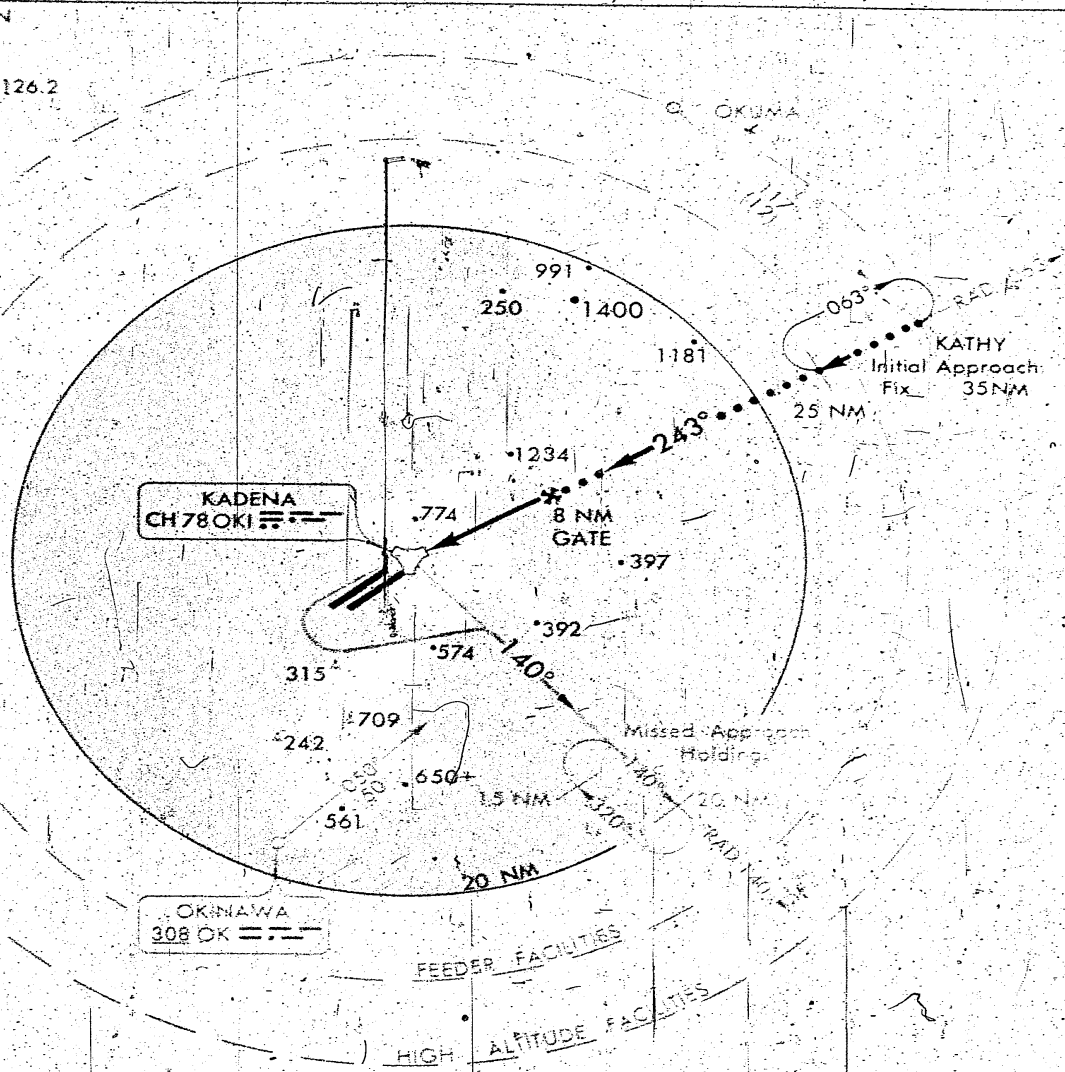

TA 18,000
EMERG SAFE ALT 100 NM 2700

MIN SAFE ALT 25 NM 2600

MISSED APPROACH
At TACAN climb on 243° to 2000. At 5.0 NM after TACAN left turn to intercept RAD-140 and hold.

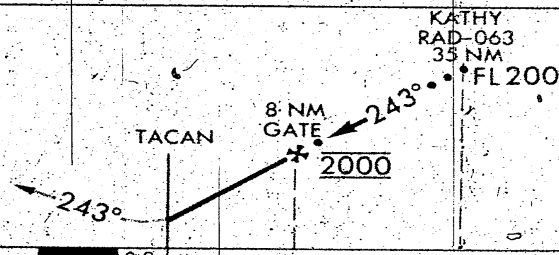

FIELD ELEV 142

CAUTION:
Construction on twys

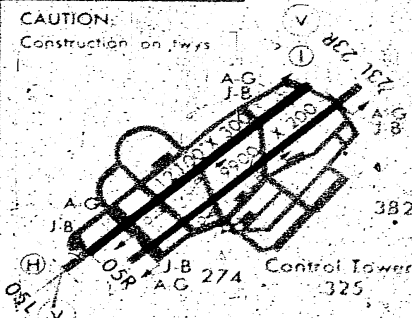

LANDING MINIMA	
Straight-in	600 MSL : 500-1
Circling*	800 MSL : 700-1
*Circling to East only.	

TACAN-RWY 23-3

26°21'N-127°46'E

KADENA, OKINAWA

KADENA AB

KADENA

NAHA

TACAN/ILS RWY 36-1

JAL 1733 (USAF)

NAHA, OKINAWA I. JAPAN NAHA AB

OKINAWA APP CON
255.4 135.9
NAHA TOWER
308.6 236.6
126.2 118.1
GND CON
284.6
PAR/ASR

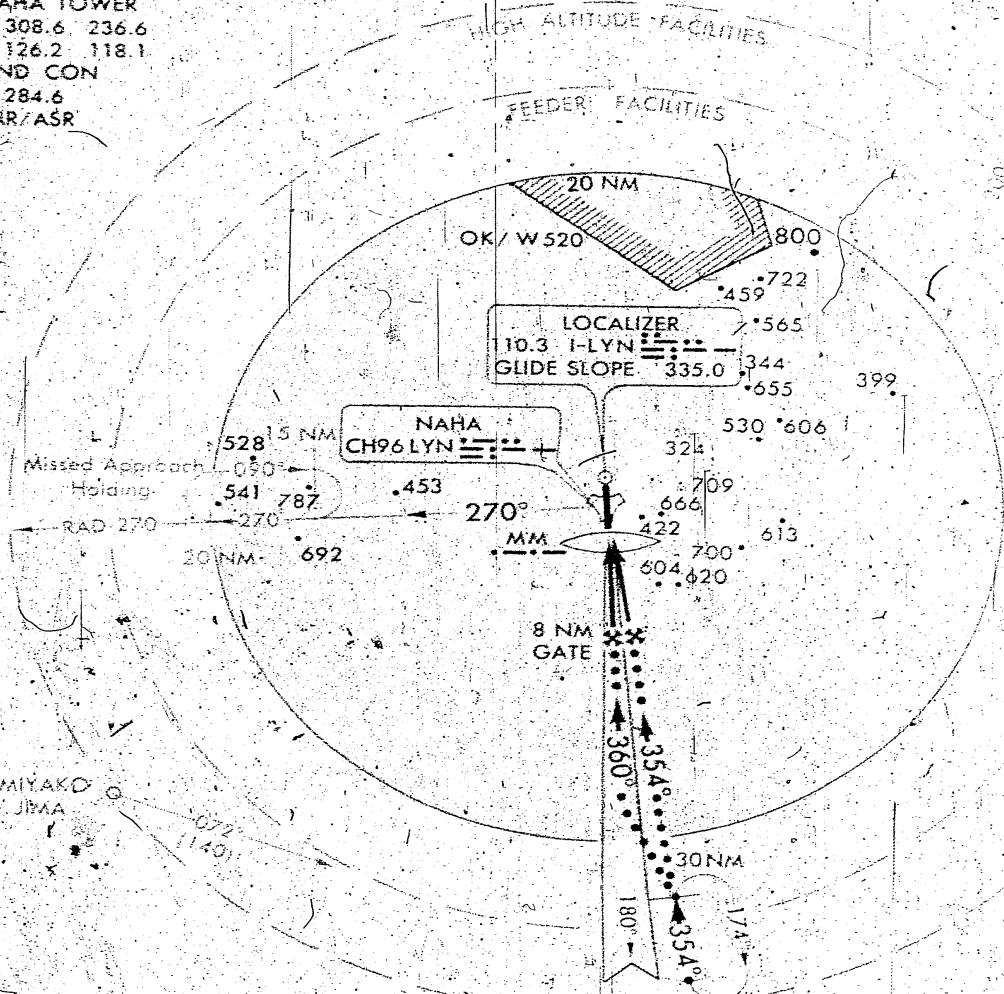

TA 18,000
EMERG SAFE ALT 100 NM 2700

RUTH
Initial Approach RAD 174
Fix 40 NM

MIN SAFE ALT 25 NM 2200

MISSED APPROACH
1.7 NM prior to TACAN left turn,
climb on RAD-270 to 2000 and hold.

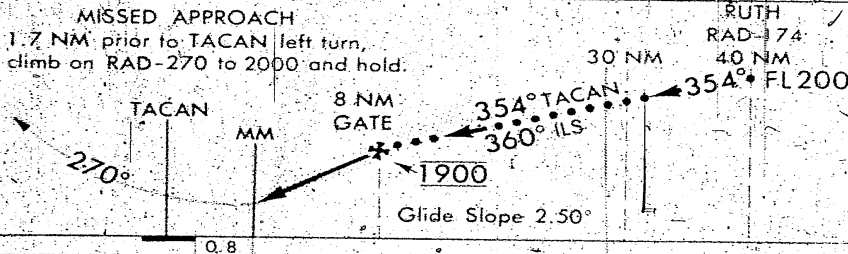

FIELD ELEV 14

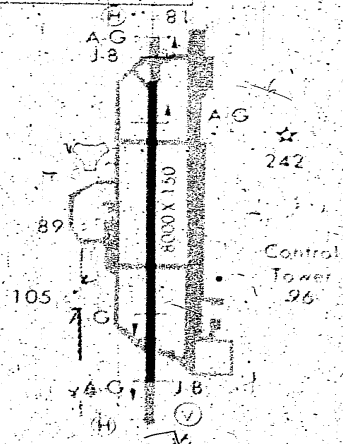

LANDING MINIMA	
Str in-ILS	314 MSL : 300-1
Str in-TACAN	500 MSL : 500-1
Circling*	600 MSL : 600-1
Str in-LOC	400 MSL : 400-1

*Circling to West only.

TACAN/ILS RWY 36-1 26°11'N-127°39'E
159

NAHA, OKINAWA I. JAPAN NAHA AB

NAHA

NAHA

TACAN/ILS-RWY 36-2

160

NAHA AB

OKINAWA APP CON
252.4 135.9
NAHA TOWER
308.6 236.6
126.2 118.1
GND CON
284.6
PAR/ASR

HIGH ALTITUDE FACILITIES
FEEDER FACILITIES

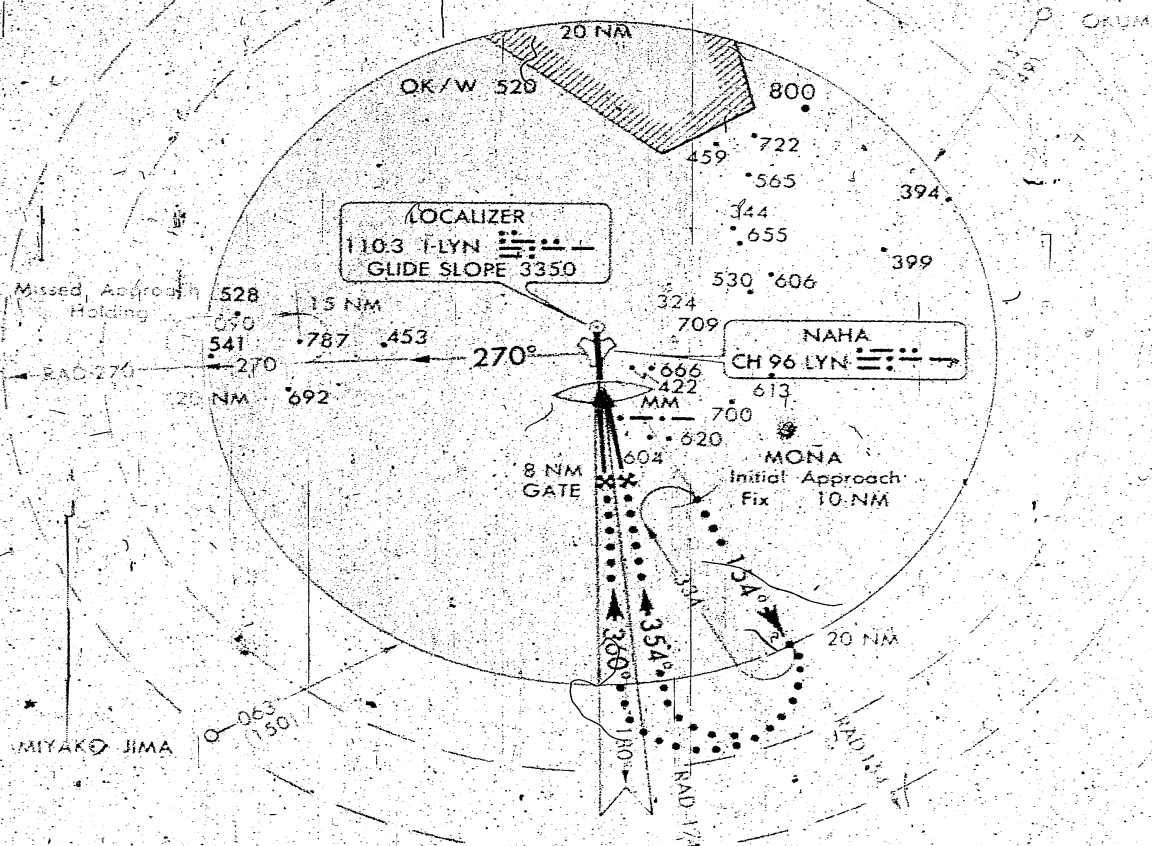

TA 18,000
EMERG SAFE ALT 100 NM 2700

MIN SAFE ALT 25 NM 2200

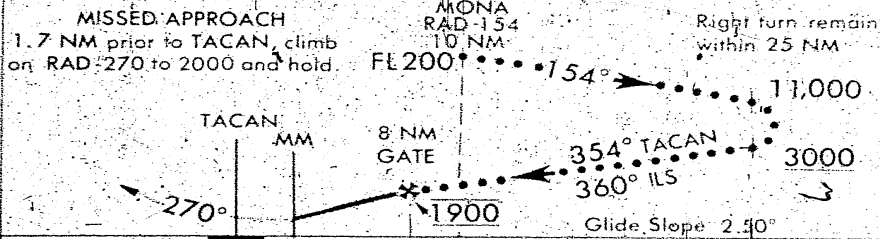

FIELD ELEV 14

LANDING MINIMA	
Str-in-ILS	314 MSL 300-1
Str-in-TACAN	500 MSL 500-1
Str-in-LOC	400 MSL 400-1
Circling *	600 MSL 600-1

* Circling to West only.

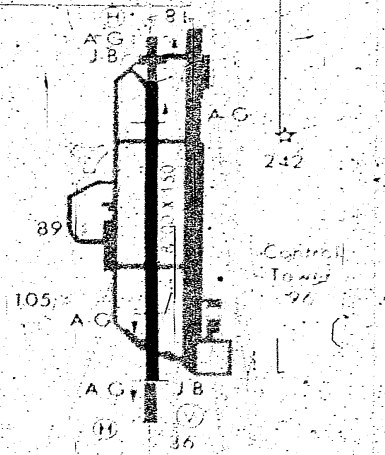

TACAN/ILS-RWY 36-2

26° 11' N - 127° 39' E

NAHA OKINAWA AB

NAHA

Page Denied

Next 3 Page(s) In Document Denied

TAOYUAN

TACAN

202

T'AO-YUAN A/D

TAI-PEI APP CON
363.8 119.7
GM TOWER
236.6 126.18
GND CON
275.8
PAR/ASR

JAL 2224 1454F

T'AO-YUAN TAOYUAN REP OF CHINA

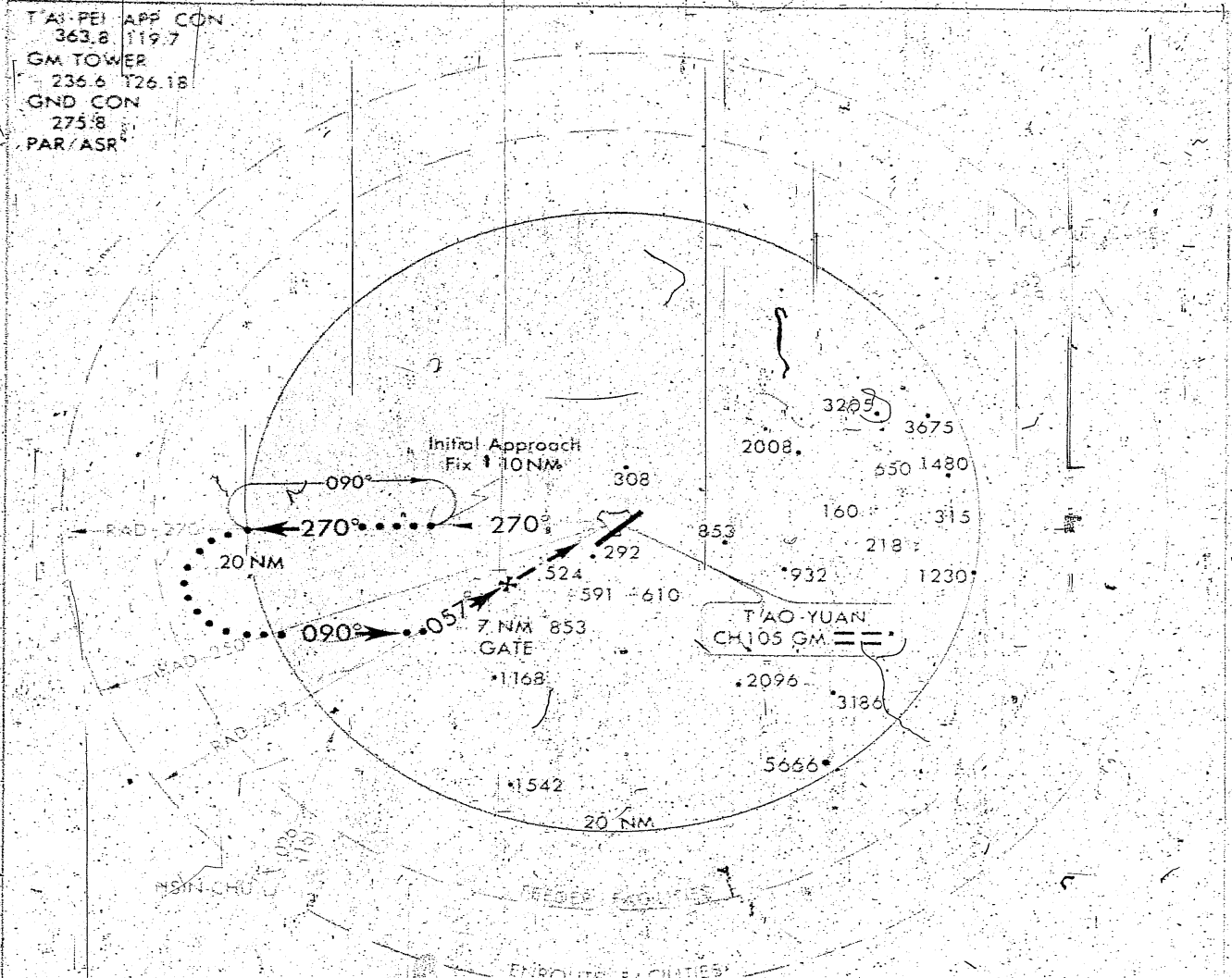

TA 18,000
EMERG SAFE ALT 100 NM 15,100
MIN SAFE ALT 25 NM 8000

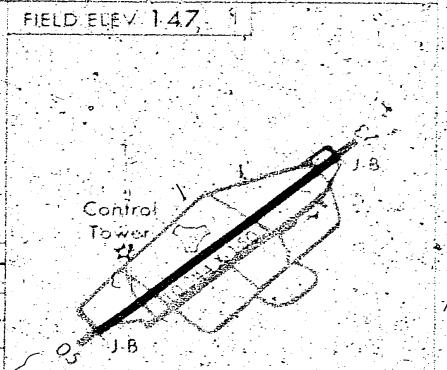
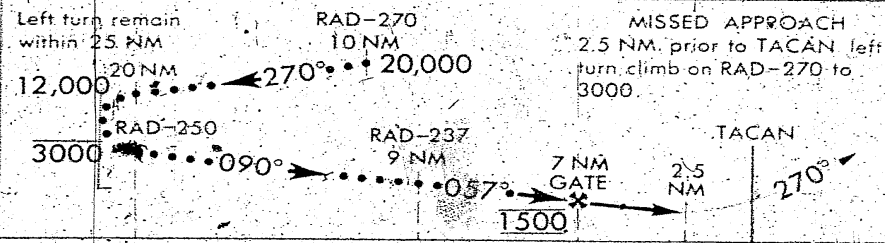

LANDING MINIMA		
Straight in	500 MSL	400-1
Circling*	600 MSL	500-1

* Circling to Northwest only.

TACAN

25°03'N-121°14'E

T'AO-YUAN TAOYUAN REP OF CHINA

T'AO-YUAN A/D

TAOYUAN

TAKHLI

TACAN-RWY 18-2

JAL 2627 (RTAF)

TAKHLI A/D
TAKHLI, THAILAND

TAKHLI APP CON
270.6 363.8 118.1
TAKHLI TOWER
253.5 236.6 126.2
GND CON
275.8
PAR/ASR

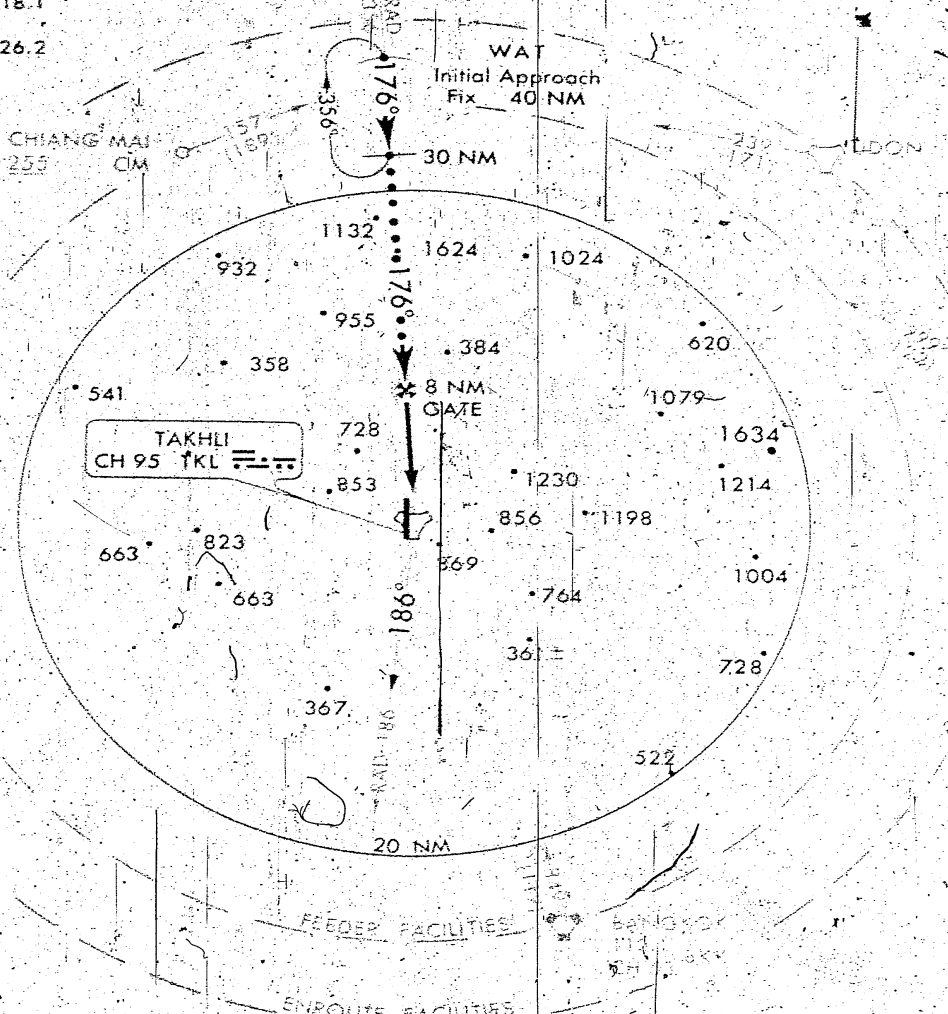

EMERG SAFE ALT 100 NM 8200

MIN SAFE ALT 25 NM 2700

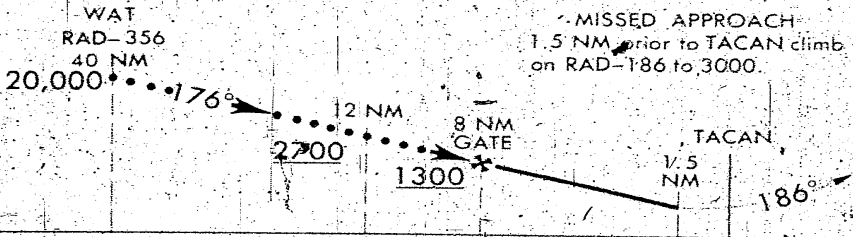

FIELD ELEV 112

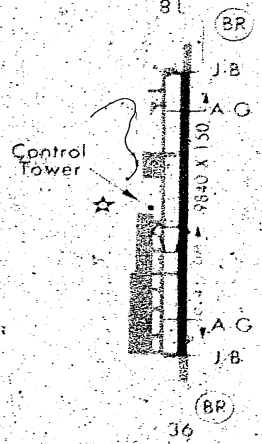

LANDING MINIMA	
Straight-in	400 MSL 300-1
Circling	NOT AUTHORIZED

TACAN-RWY 18-2

15°16'N-100°18'E
195

TAKHLI A/D
TAKHLI, THAILAND

TAKHLI

TAKHLI

TACAN - RWY 36

196

JAL 2627 IRTAF

TAKHLI A/D

TAKHLI THAILAND

TAKHLI APP CON
270.6 363.8 118.1
TAKHLI TOWER
253.5 236.6 126.2
GND CON
275.8
PAR/ASR

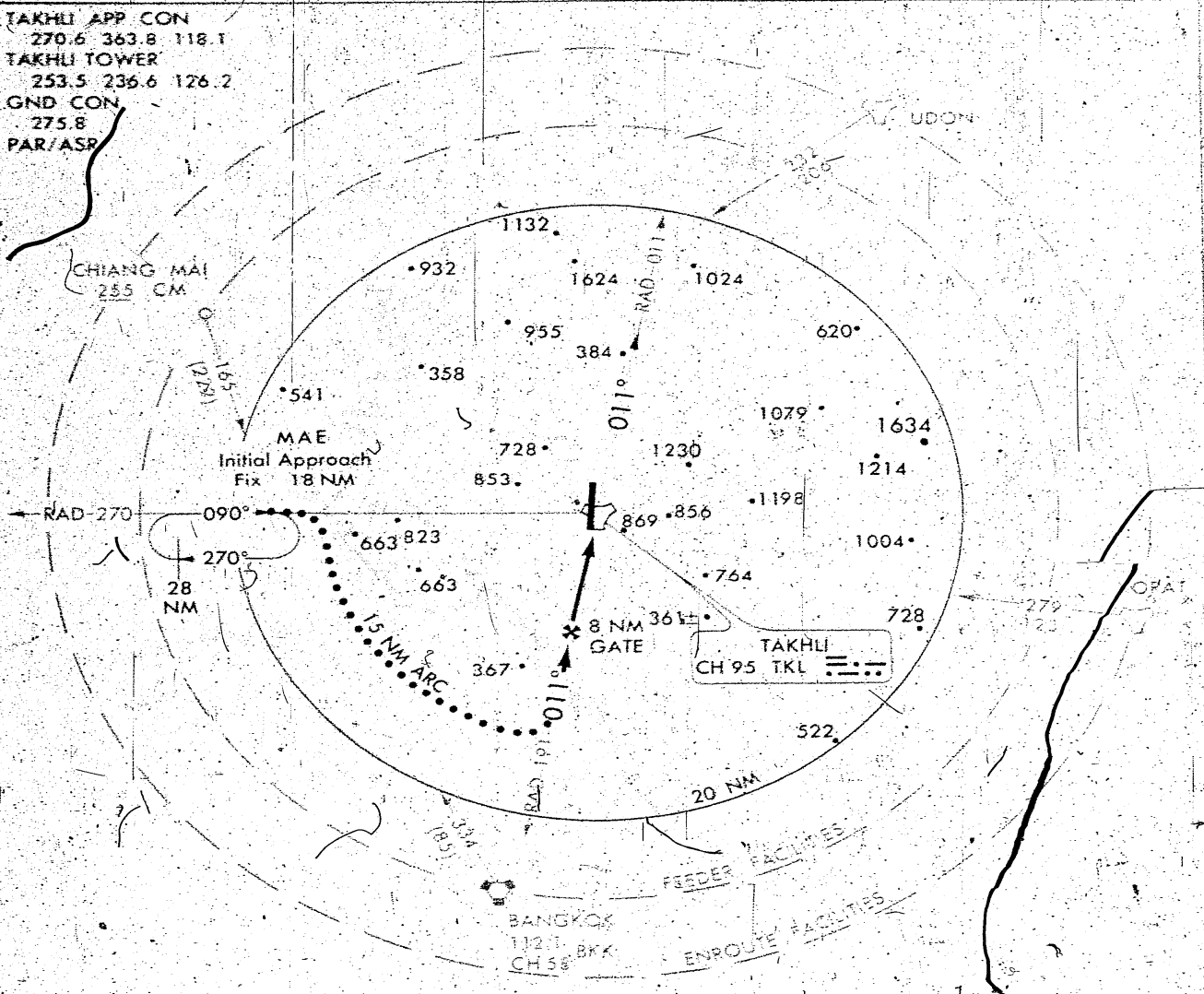

EMERG SAFE ALT 100 NM 8200

MIN SAFE ALT 25 NM 2700

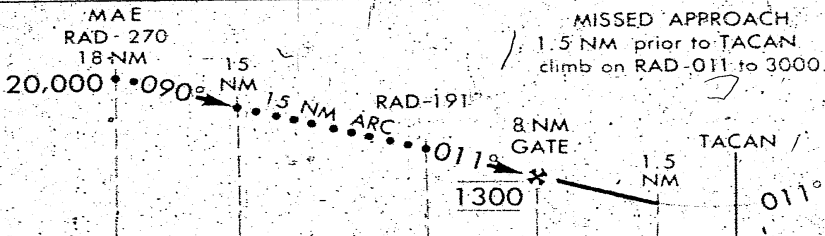

FIELD ELEV 112

LANDING MINIMA	
Straight-in	400 MSL 300-1
Circling	NOT AUTHORIZED

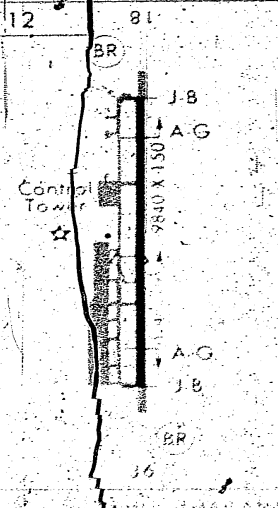

TACAN-RWY 36

15°16'N-100°18'E

TAKHLI A/D

TAKHLI

DTG 379
 ETA +59
 ETE :21
 TH 237°
 MH 237°
 FUEL TO CONT
 61,100 #

LG 305
 CHU
 24-49N
 120-56E
 PO 92
 PO 375

TACAN - OFF
 IFF/SIF - OFF
 AR BCN - OFF
 MIC SEL - OFF

POS 28
 TAOYUAM
 GM105
 GM400

POS 02
 EAR
 22-40N
 124-30E
 T.O. +37

AEROT FUEL
 13,100 #
 DTG 87NM

POS 01/38
 ARCP
 24-19N
 125-58E

PACKAGE CHECK
 T FL 250 GO TO "C" POS.
 R "OPERATE" FOR ONE MIN.
 WHEN BACK TO Q-BAY 2.

A-CODE
 TH 222
 MH 224
 DTG 156

I/R # 1
 CALL SIGN
 RCT T.O. +22
 PRI CH 17 (390.1)
 SEC CH 18 (388.0)
 ARC 50 CODE 70060-1

POS 27
 NAHA
 LYN 96

POS 00
 26-21N
 127-46E

BEFORE TAKEOFF
 AR BCN ON
 Q-BAY 2

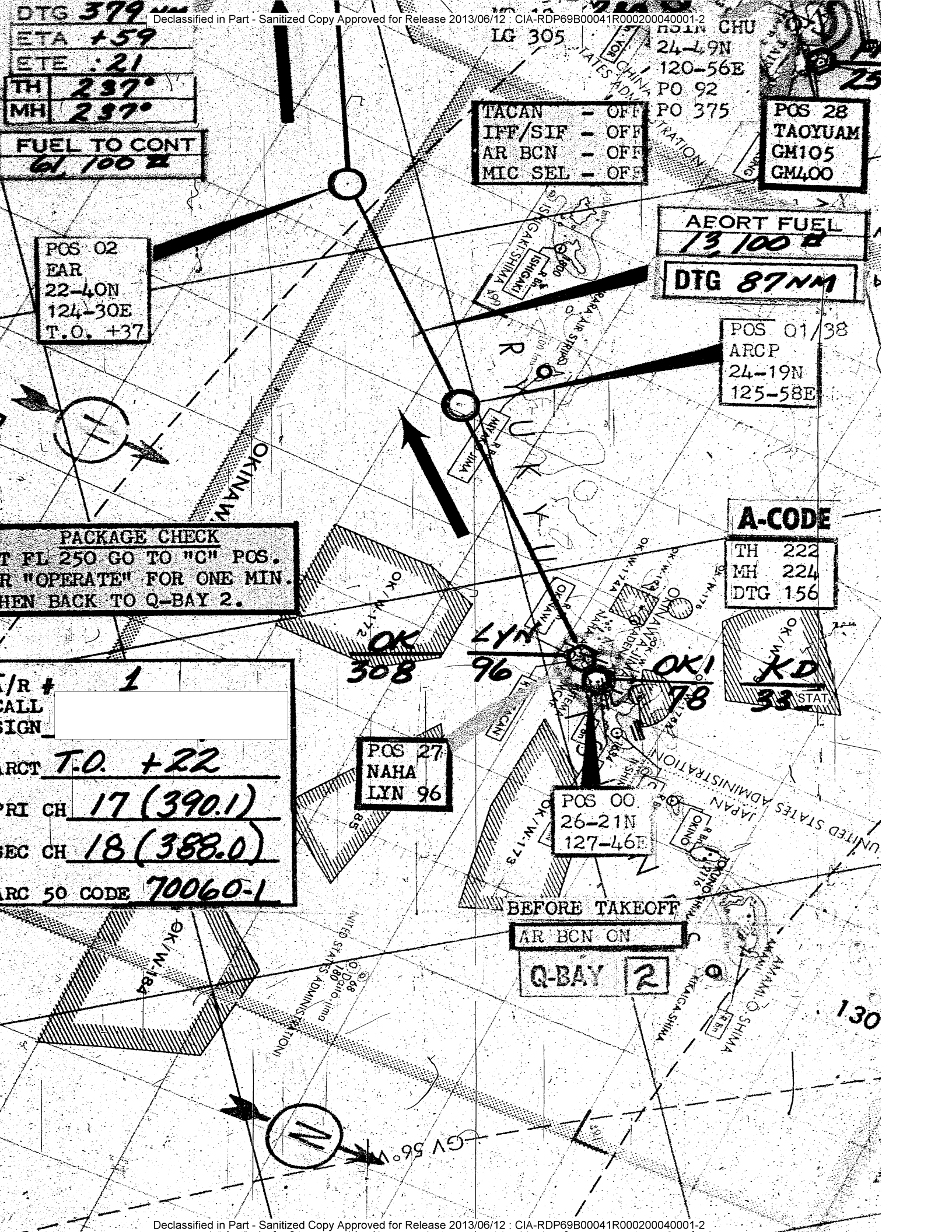

Page Denied

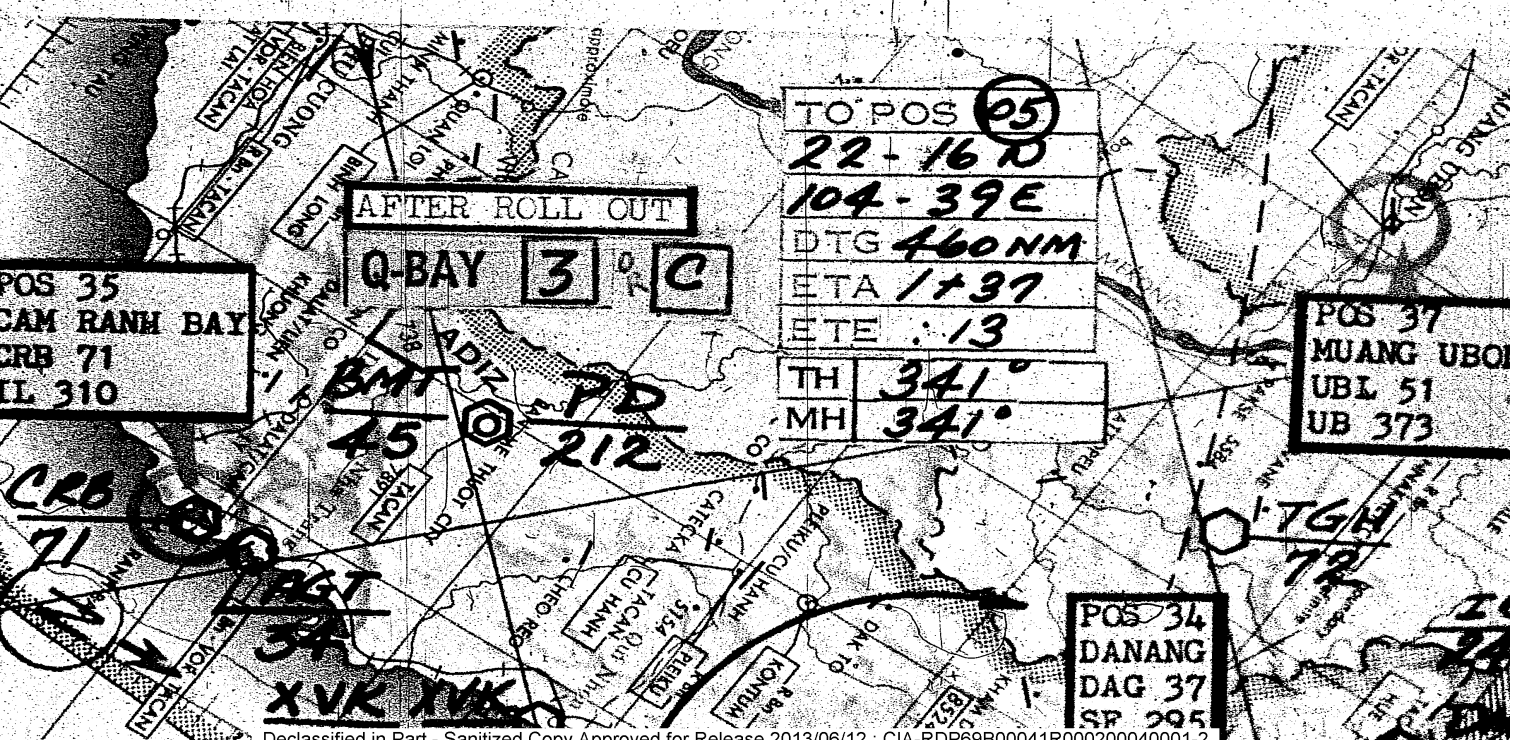
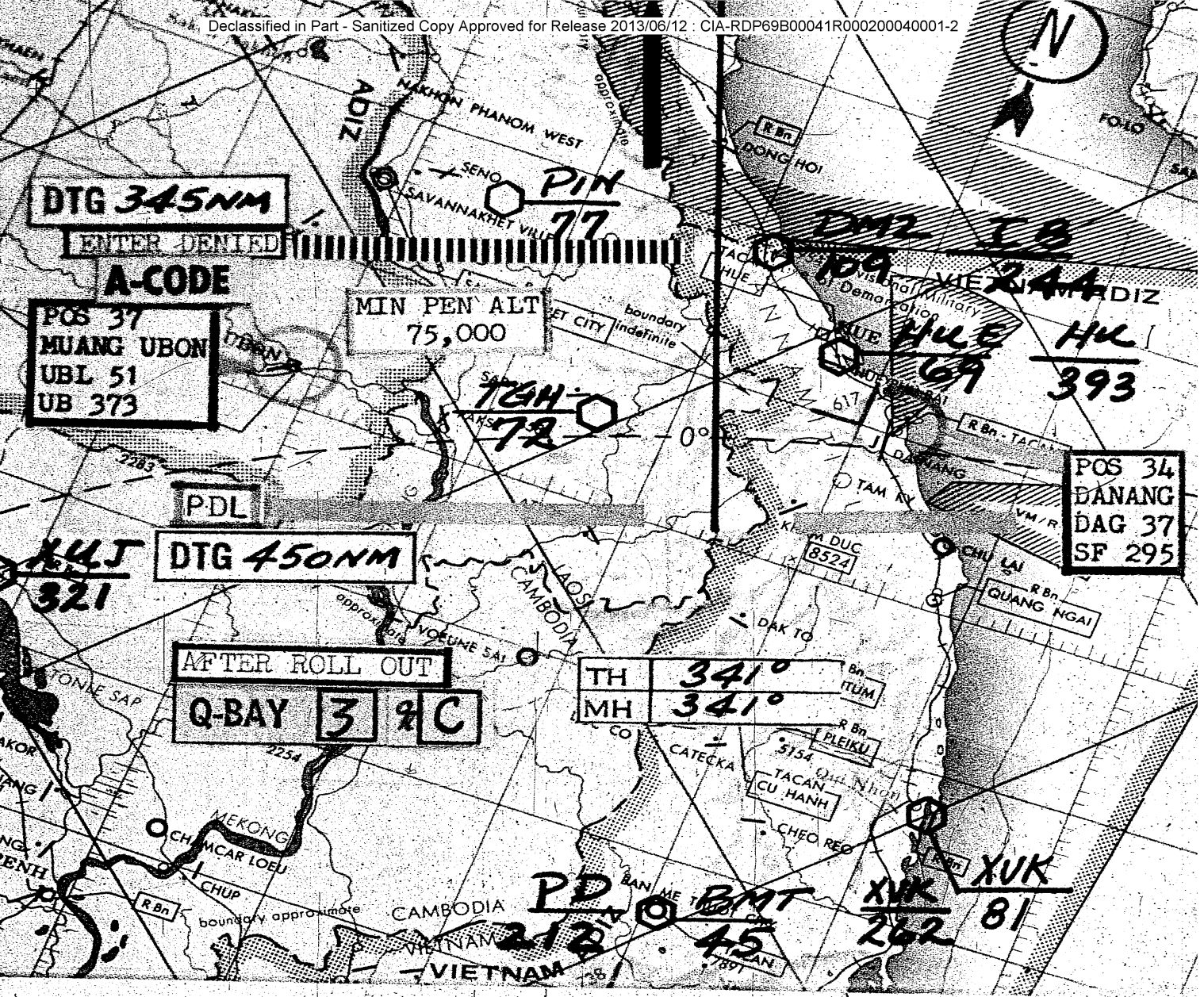

EXIT DENIED
DTG / 80 NM

A-CODE

Q-BAY 2

SIP-OFF

DTG 225 NM

UWS-OFF

DTG 29 NM

KG
400

START DESCENT
TIME / +47 / +09
DTG 225 NM
FUEL 18.1 / 11.8

TACAN - ON
IFF/SIF - ON
AR BCN - AS REQD
MIC SEL - UHF/HF

A/R # 2
CALL SIGN
ARCT T.O. + 2+00
PRI CH 19 (389.2)
SEC CH 20 (392.8)
ARC 50 CODE 70060-1

TH 208°
MH 208°

TO POS (07) (39)
17-00N
99-40E
DTG 317 NM
ETA 2+00
ETE : 16
TH 208°
MH 208°

POS (06)
22-23N
102-47E
DTG 52 NM

POS (05)
TIME / +37 / +00
DTG 52 NM
FUEL 22.7 / 6.5

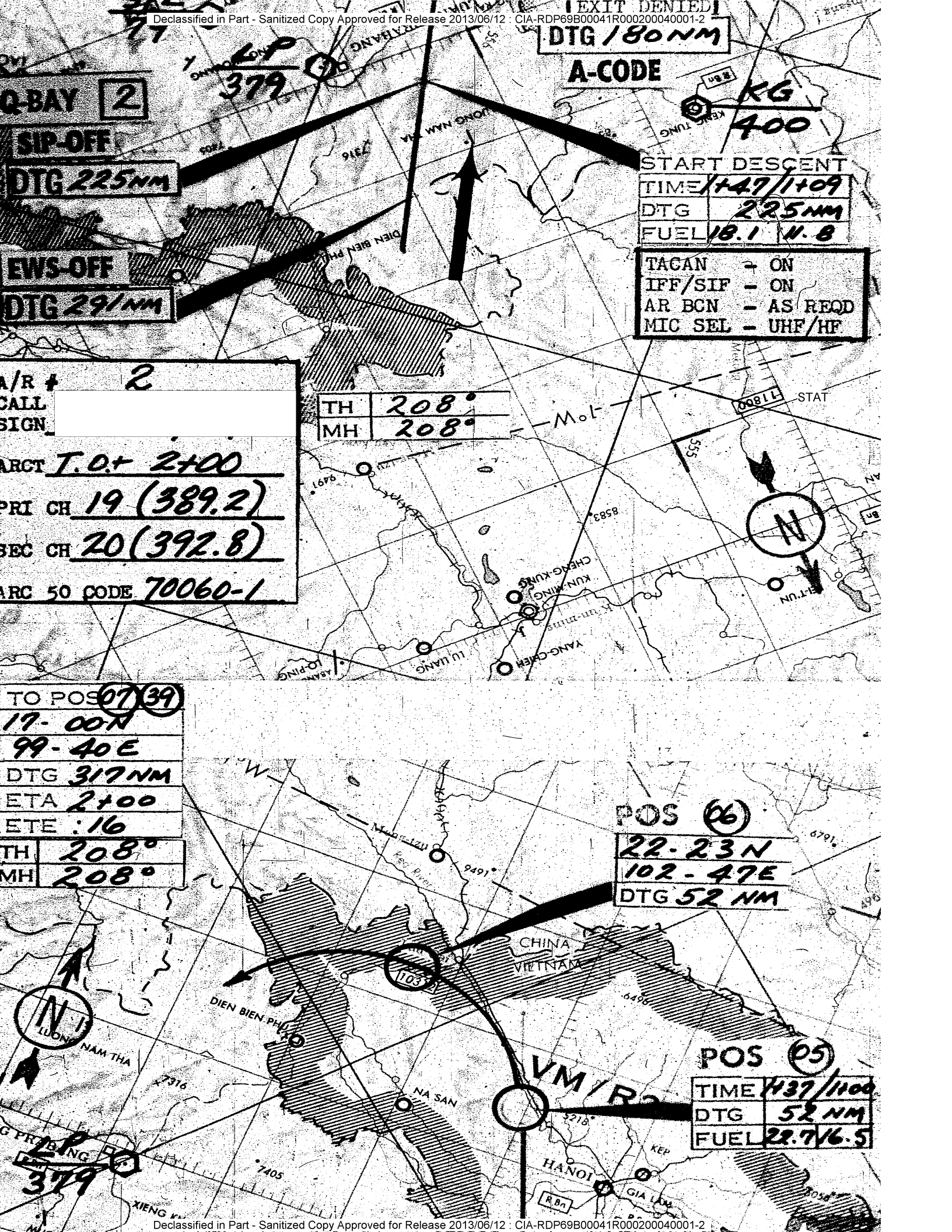



POS 30
TAKHLI
TKL 43
TL284

BANGKOK
13-55N
100-37E
BKK 58
DA 395

POS 33
UTAPAO
BUT 45
BT 414

TO POS (09)
17-38N
109-20E
DTG 594 NM
ETA 2+47
ETE :26
TH 070°
MH 070°

POS 33
UTAPAO
BUT 45
BT 414

TACAN - OFF
IFF/SIF - OFF
AR BCN - OFF
MIC SEL - OFF

POS (08)

END AR
14-15N
99-40E
TIME 2+20
FUEL TO CONT
50,200 #

BANGKOK
13-55N
100-37E
BKK 58
DA 395

POS 32
ORAT
RT 125
230

TH 070°
MH 070°

AEORT FUEL
9,200 #
DTG 125 NM

TH 178°
MH 178°

POS 30
TAKHLI
TKL 43
TL284

ARCP TO TAKHLI
160/111 nm

POS (07) (39)

ARCP
19-00N
99-40E
TIME 2+00/1+22

TH 067°
MH 067°

ABORT FUEL 9,200 E
DTG 125 NM

TH 178°
MH 178°

PCS 30
TAKHLI
TKL 43
TL284

POS (11) (39)

SS 32
DRAT
T 125
230

ARCP TO TAKHLI
160/111 nm

ARCP
17-00N
99-40E
TIME 3+22/1+01
FUEL 29.5 10.4

EM
255

DTG/59 NM
EXIT DENIED
A-CODE

CRP 200
279

SIP-OFF
DTG 225 NM

START DESCENT
TIME 3+08/1+48
DTG 225 NM
FUEL 29.1 12.0

Q-BAY 2

TACAN - ON
IFF/SIF - ON
AR BCN - AS REQD
MIC SEL - UHF/HF

EWS-OFF
DTG 274 NM

A/R # 3
CALL SIGN

TO POS (11) (39) STAT
17-00N
99-40E
DTG 344 NM
ETA 3+22
ETE : 18

ARCT T.O. + 3+22
PRI CH 19 (389.2)

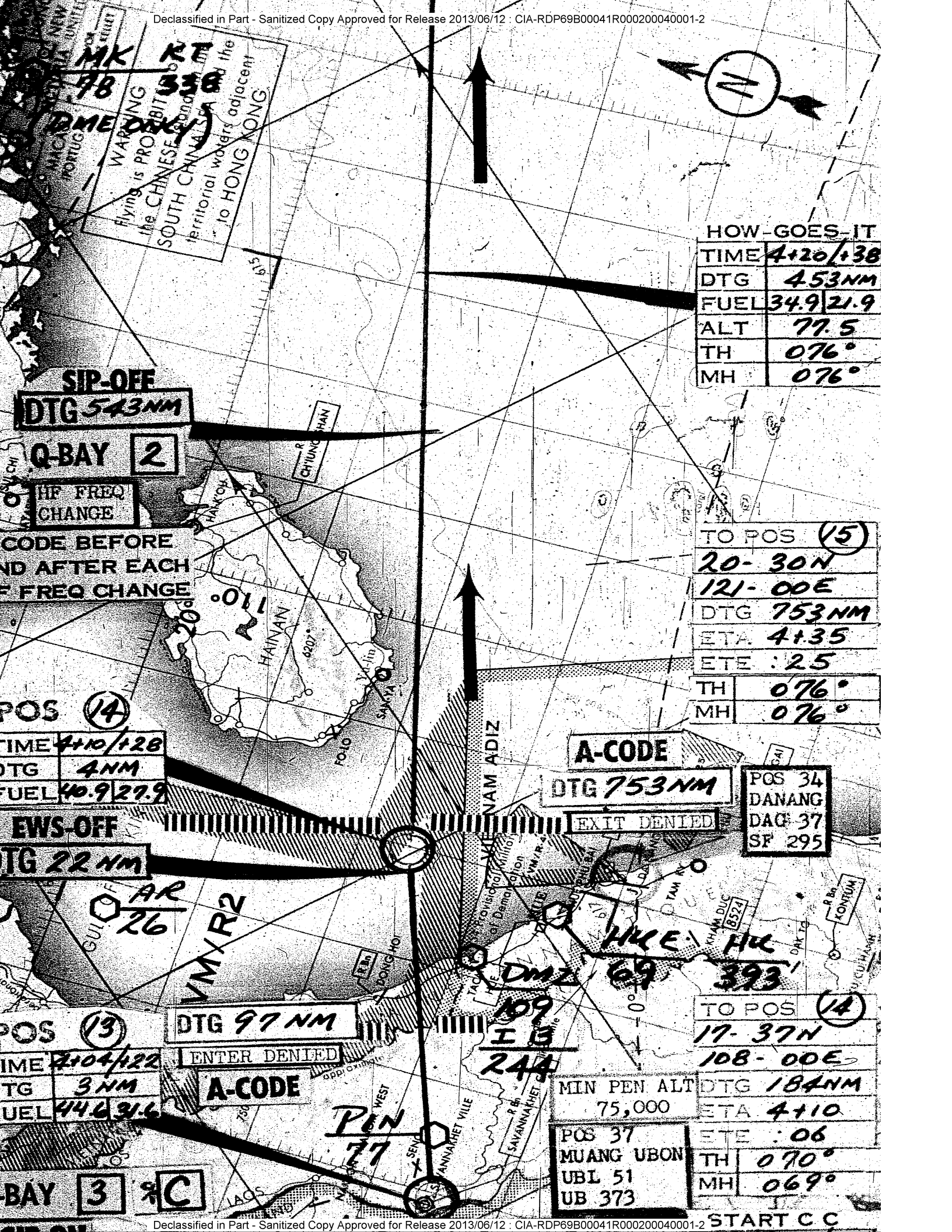

HOW-GOES-IT

TIME	4+20/138
DTG	453NM
FUEL	34.9/21.9
ALT	77.5
TH	076°
MH	076°

SIP-OFF
DTG 543NM

Q-BAY 2

HF FREQ
CHANGE

CODE BEFORE
AND AFTER EACH
FREQ CHANGE

POS (14)

TIME	4+10/128
DTG	4NM
FUEL	40.9/27.9

EWS-OFF
DTG 22 NM

AR 26
VMXR2

POS (13)

TIME	4+04/122
DTG	3 NM
FUEL	44.6/31.6

DTG 97 NM

ENTER DENIED

A-CODE

BAY 3 *C

TO POS (15)

TIME	20-30N
DTG	121-00E
DTG	753NM
ETA	4+35
ETE	:25
TH	076°
MH	076°

A-CODE
DTG 753NM

POS 34
DANANG
DAG 37
SF 295

EXIT DENIED

DMZ 69 393

TO POS (14)

TIME	17-37N
DTG	108-00E
DTG	184NM
ETA	4+10
ETE	:06
TH	070°
MH	069°

MIN PEN ALT
75,000

POS 37
MUANG UBON
UBL 51
UB 373

DTG	184NM
ETA	4+10
ETE	:06
TH	070°
MH	069°

START C C

Page Denied

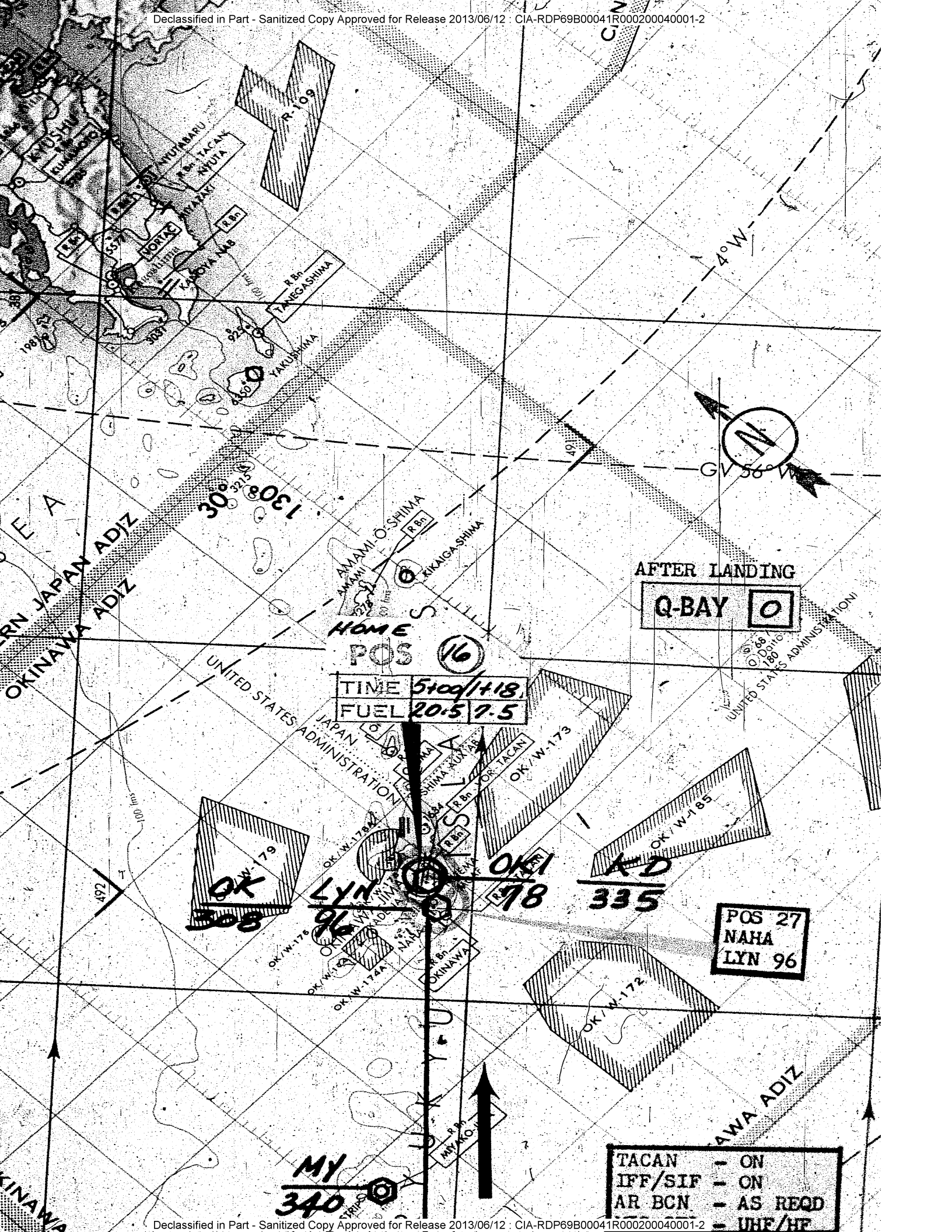

TIME 5:00/148
FUEL 20.5/7.5

AFTER LANDING
Q-BAY

HOME POS (16)

POS 27
NAHA
LYN 96

TACAN - ON
IFF/SIF - ON
AR BCN - AS REQD
UHF/HF

MY
340

OK/W-179
OK/W-178

OK/W-178
OK/W-173
OK/W-185

OK/W-172

OKINAWA ADIZ
JAPAN ADIZ

UNITED STATES ADMINISTRATION

UNITED STATES ADMINISTRATION
JAPAN ADMINISTRATION

OKINAWA ADIZ

KADENA

TACAN/ILS-RWY 05-1

100

JAL-1457 (USAF)

KADENA OKINAWA I. RYUKYU ISLANDS

KADENA AB

OKINAWA APP CON
255.4 1045.9
KADENA TOWER
315.8 236.6 126.2
GND CON
275.8
PAR/ASR

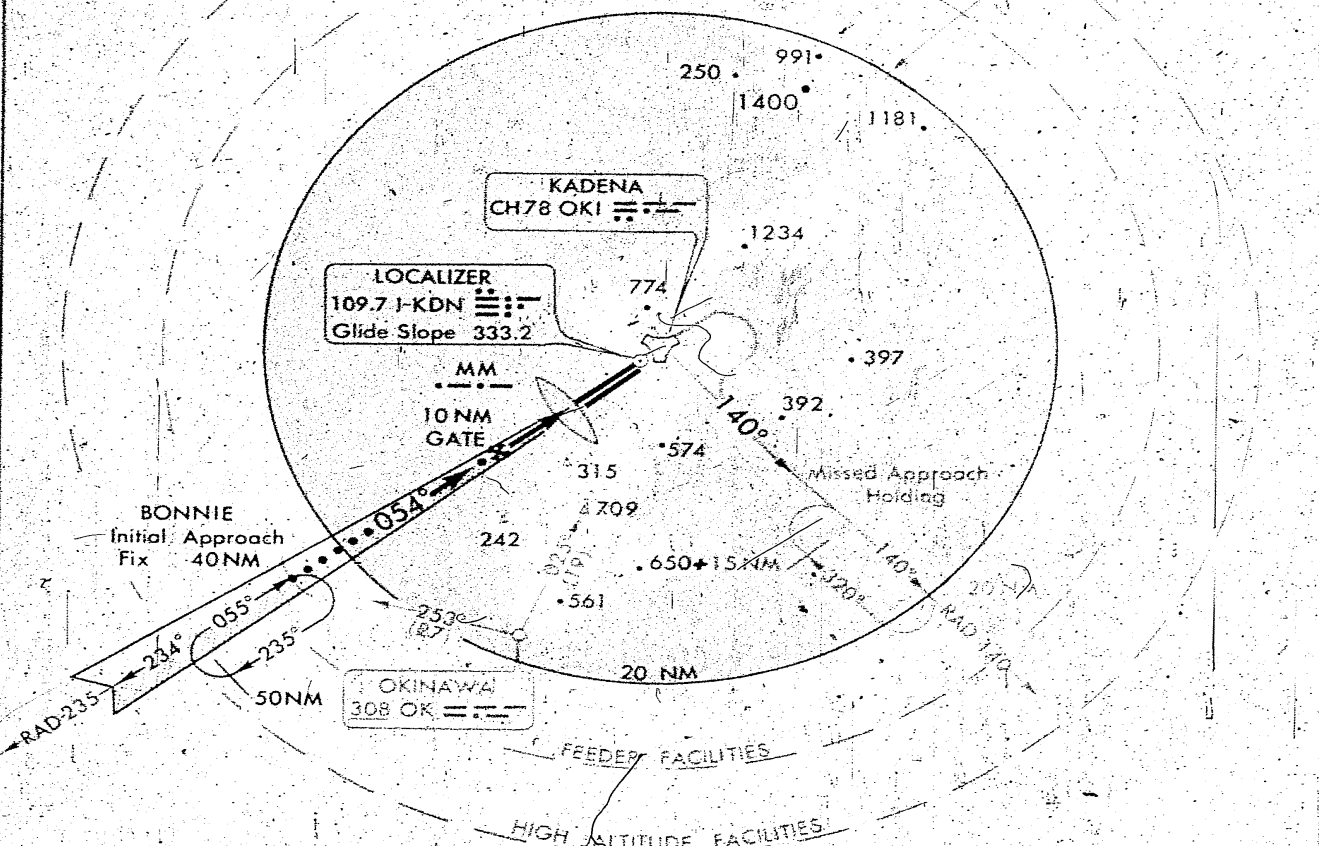

TA 18,000
EMERG SAFE ALT 100 NM 2700

MIN SAFE ALT 25 NM 2600

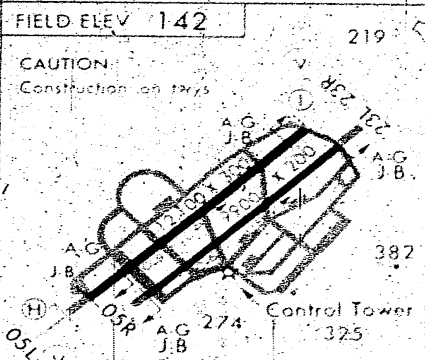
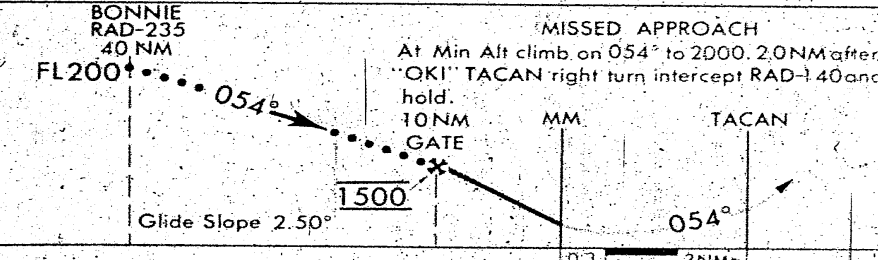

LANDING MINIMA

Str-in-ILS	342 MSL	200-1/2 or RVR 24
Str-in-TACAN	400 MSL	300-1
* Circling	800 MSL	700-1

* Circling to East only.

TACAN/ILS-RWY 05-1

26°21'N-127°46'E

KADENA OKINAWA I. RYUKYU ISLANDS

KADENA AB

KADENA

KADENA

TACAN-RWY 23-3

JAL-1457 (USAF)

KADENA, OKINAWA I., RYUKYU ISLANDS

OKINAWA APP CON.
255.4 135.9
KADENA TOWER
315.8 236.6 126.2
GND CON
275.8
PAR/ASR

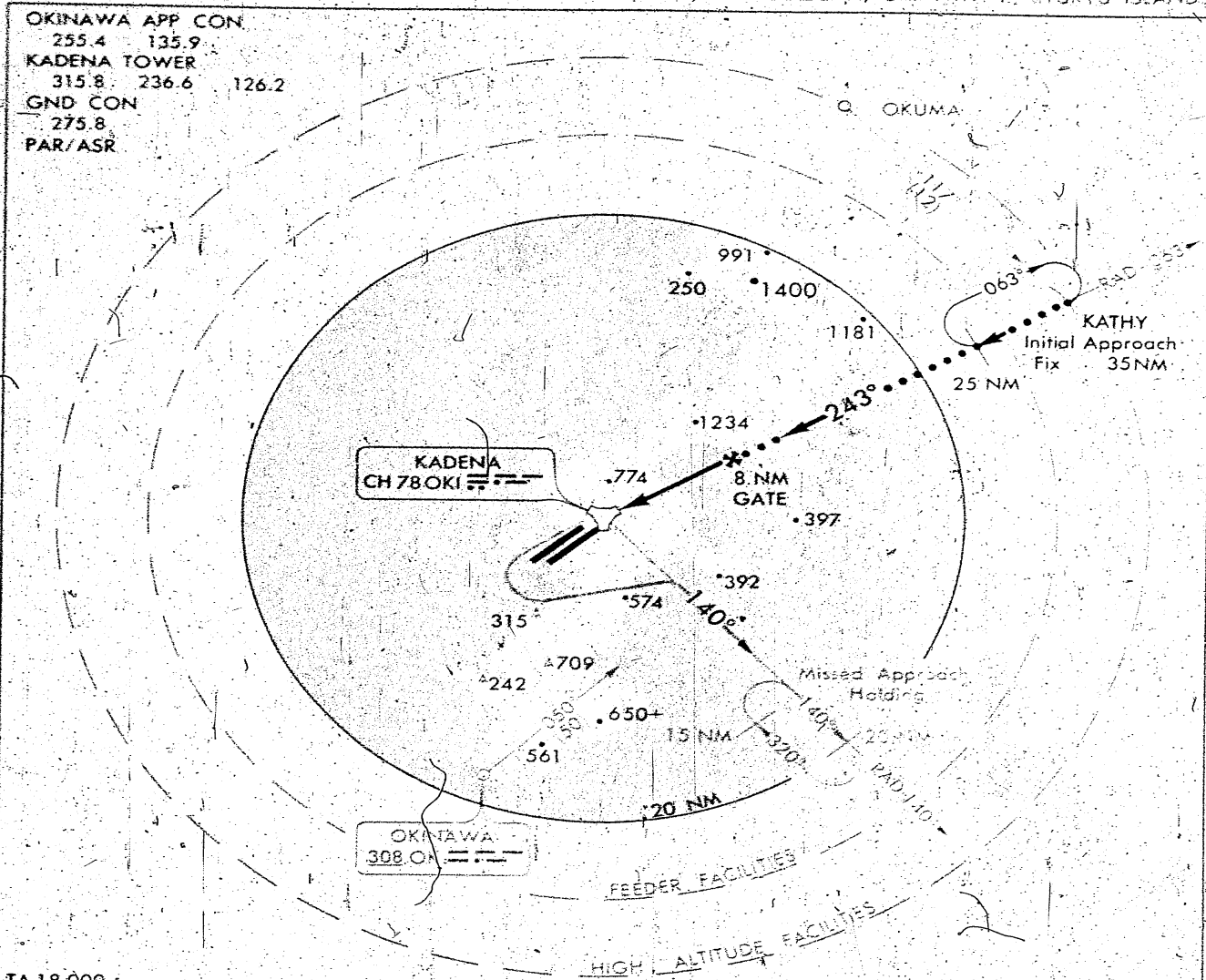

TA 18,000
EMERG SAFE ALT 100 NM 2700

MIN SAFE ALT 25 NM 2600

MISSED APPROACH
At TACAN climb on 243° to 2000. At 5.0 NM after TACAN left turn to intercept RAD-140 and hold.

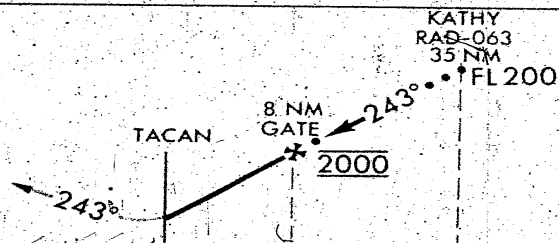

FIELD ELEV 142 219

CAUTION
Construction on twys

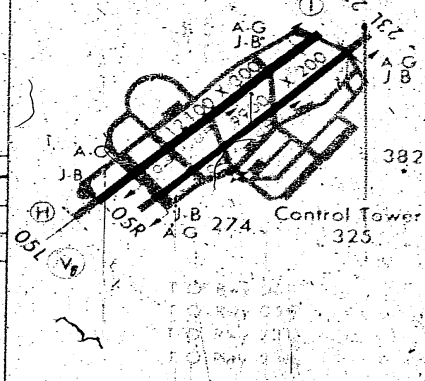

LANDING MINIMA

Straight-in	600 MSL	500-1
Circling	800 MSL	700-1

* Circling to East only.

TACAN-RWY 23-3

26°21'N-127°46'E

KADENA, OKINAWA I., RYUKYU ISLANDS

99

KADENA AB

KADENA

NAHA

TACAN-RWY 18

158

NAHA AB

OKINAWA APP CON
255.4 135.9
NAHA TOWER
308.6 236.6
126.2 118.1
GND CON
284.6
PAR/ASR

JAL 1237 (USAF)

NAHA OKINAWA

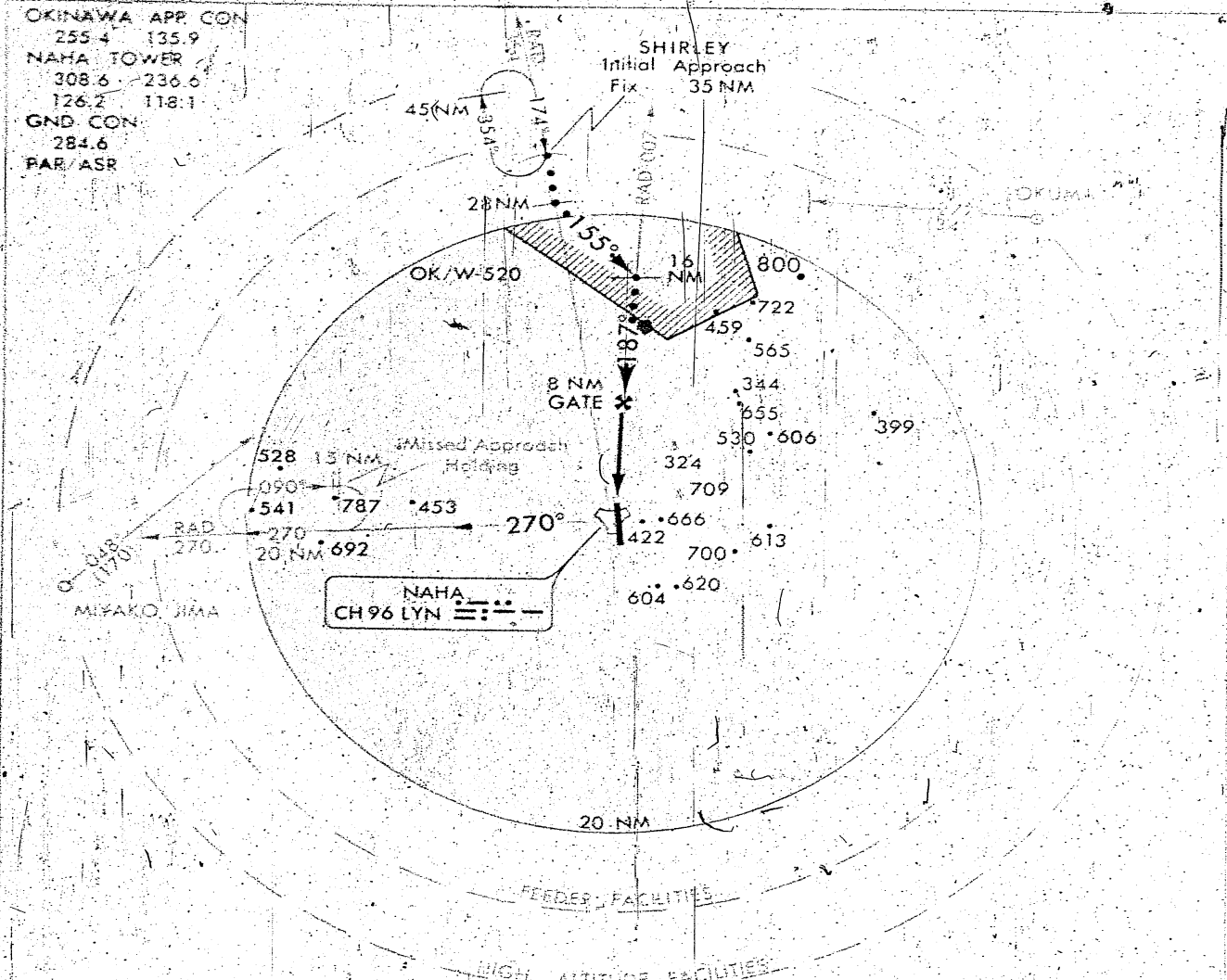

TA 18,000

EMERG SAFE ALT 100 NM 2700

MIN SAFE ALT 25 NM 2200

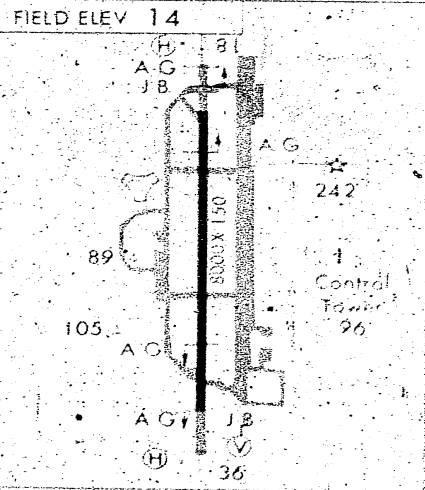
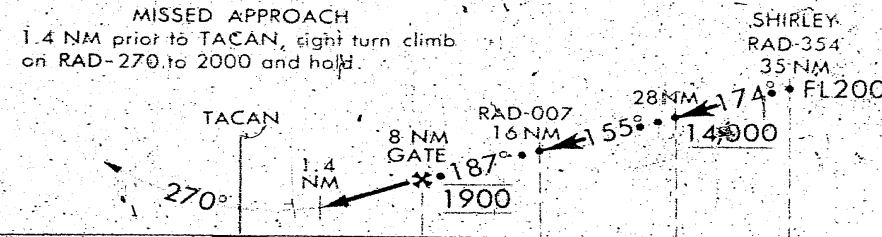

LANDING MINIMA	
Straight-in	400 MSL 400-1
Circling *	600 MSL 600-1

* Circling to West only

TACAN-RWY 18

26°11'N-127°39'E

NAHA OKINAWA NAHA AB

NAHA

NAHA

TACAN/ILS RWY 36-1

JAL 1733 (USAF)

NAHA AB

NAHA, OKINAWA I. RYUKYU IS.

OKINAWA APP CON
255.4 135.9
NAHA TOWER
308.6 236.6
126.2 118.1
GND CON
284.6
PAR/ASR

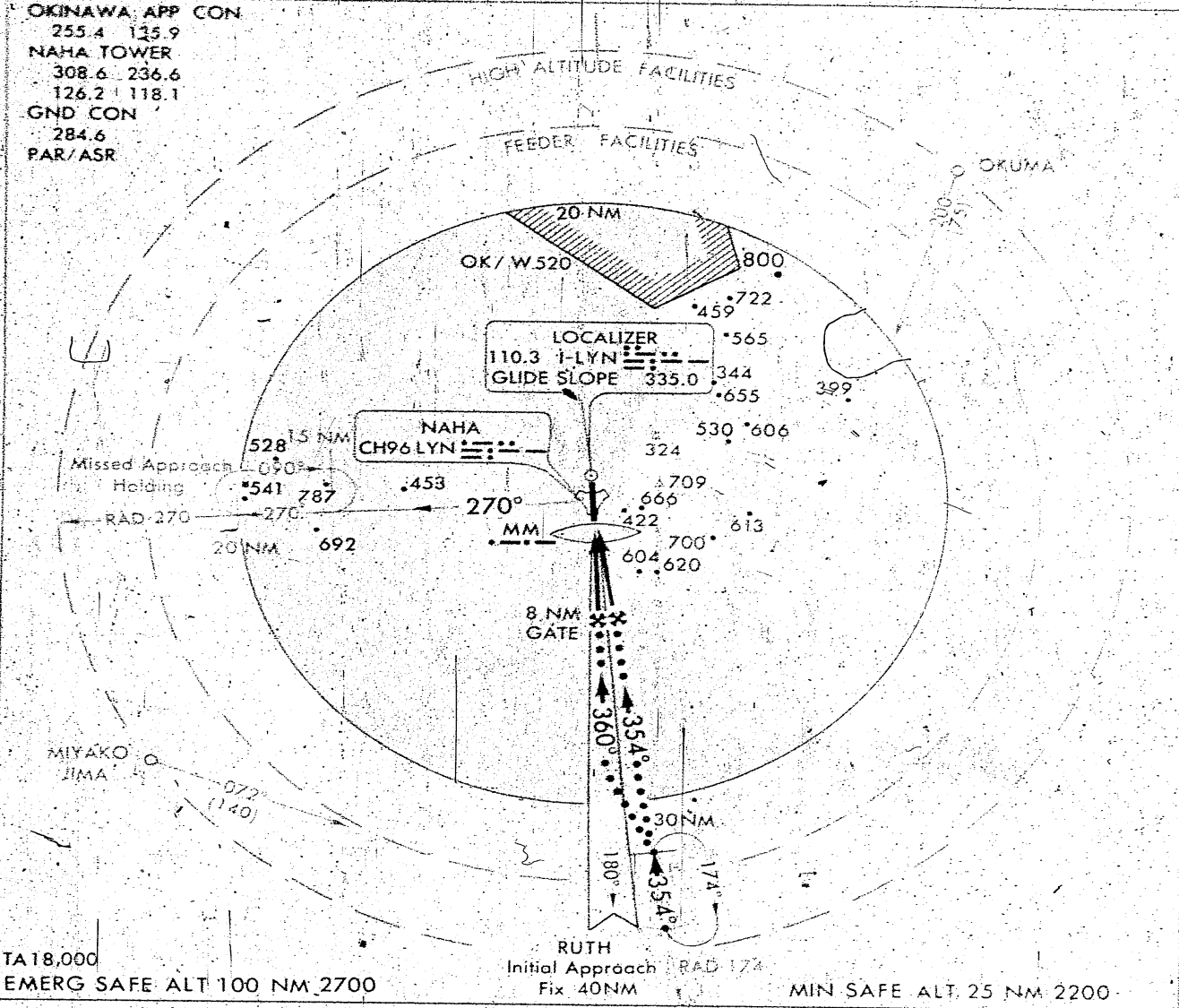

TA 18,000
EMERG SAFE ALT 100 NM 2700

MIN SAFE ALT 25 NM 2200

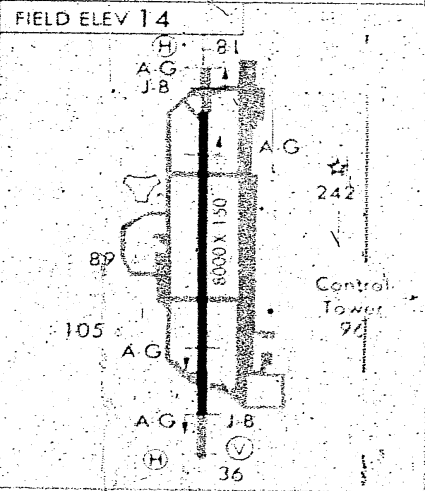
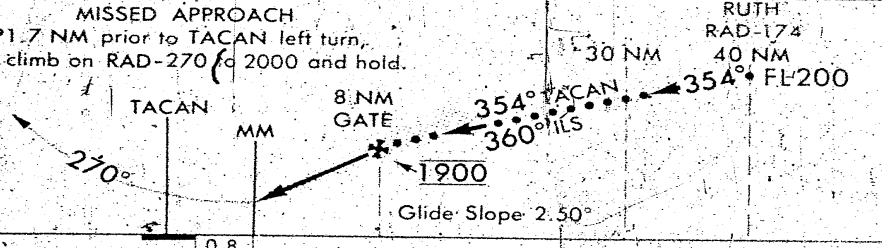

LANDING MINIMA			
Str-in-ILS	314 MSL	300-1	
Str-in-TACAN	500 MSL	500-1	
Circling*	600 MSL	600-1	
Str-in-LOC	400 MSL	400-1	

*Circling to West only.

TACAN/ILS RWY 36-1

26°11'N-127°39'E

159

NAHA AB

NAHA

NAHA

TACAN/ILS-RWY 36-2

160

JAL 1783 (USAF)

NAHA AB

NAHA, OKINAWA

OKINAWA APP CON
 255.4 135.9
 NAHA TOWER
 308.6 236.6
 126.2 118.1
 GND CON
 284.6
 PAR/ASR

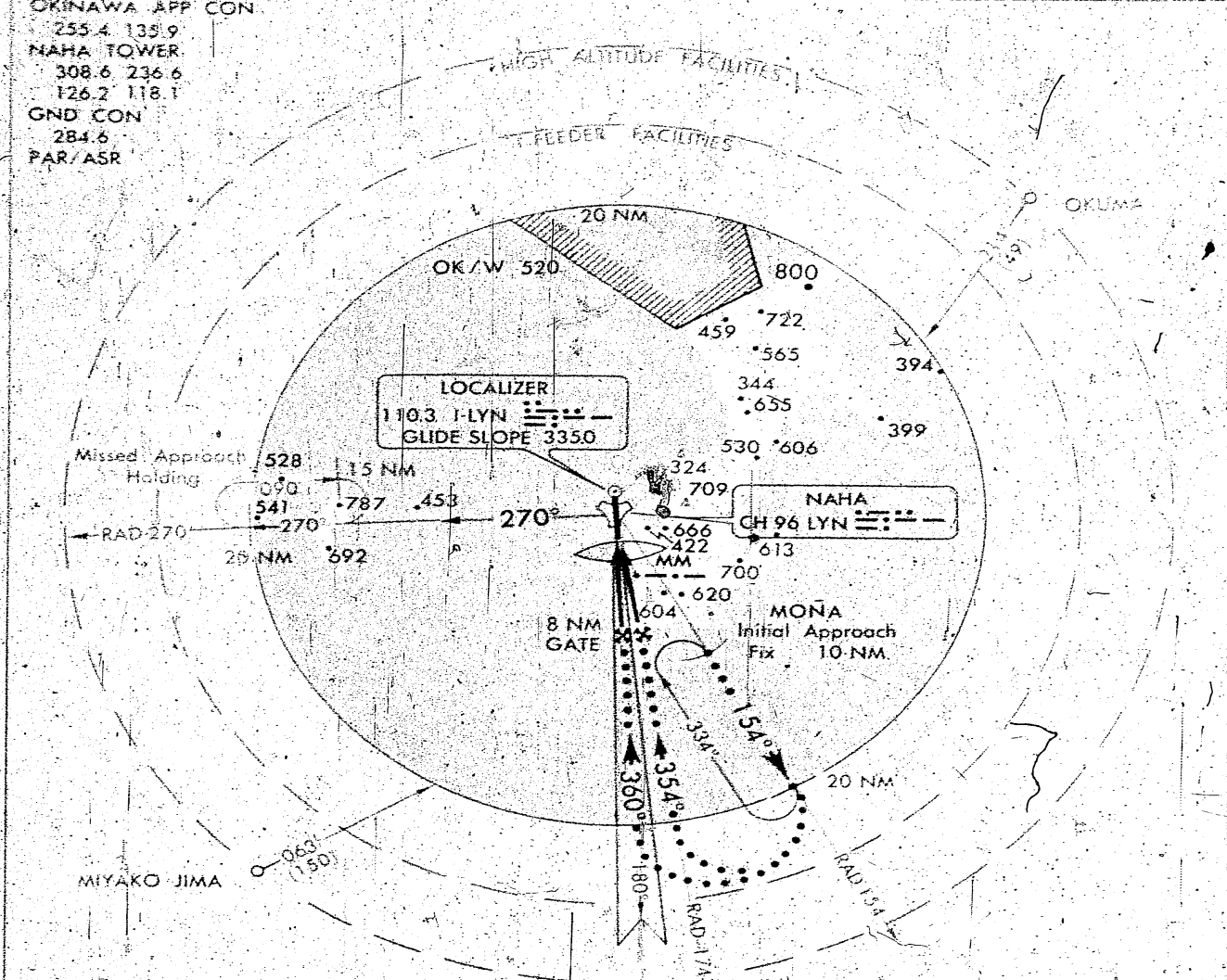

TA 18,000
 EMERG SAFE ALT 100 NM 2700

MIN SAFE ALT 25 NM 2200

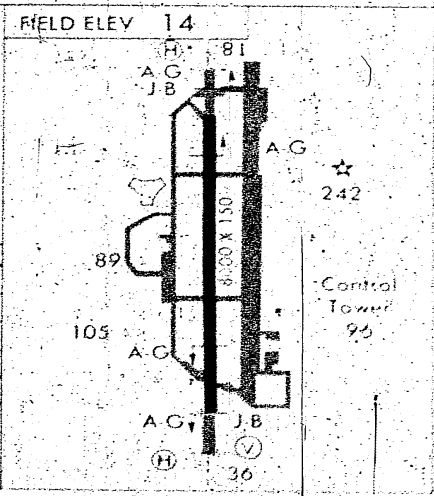
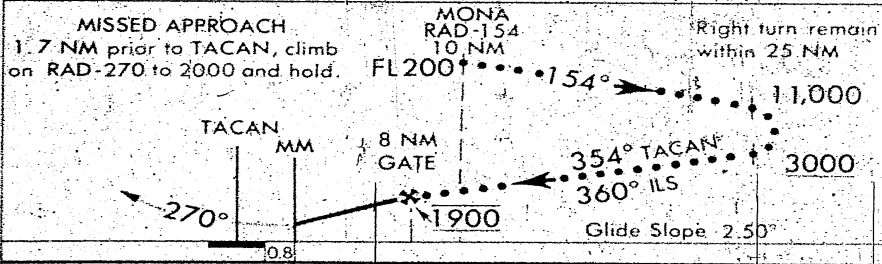

LANDING MINIMA			
Str-in-ILS	314 MSL	300-1	
Str-in-TACAN	500 MSL	500-1	
Str-in-LOC	400 MSL	400-1	
Circling *	600 MSL	600-1	

* Circling to West only.

TACAN/ILS-RWY 36-2

26°11'N-127°39'E

NAHA, OKINAWA

NAHA AB

NAHA

Page Denied

Next 3 Page(s) In Document Denied

TAOYUAN

TACAN

202

T'AO-YUAN A/D

M 222 (USAF)

T'AO YUAN, TAIWAN, REP. OF CHINA

T'AI-PEI APP CON
363.8 119.7
GM TOWER
236.6 126.18
GND CON
275.8
PAR/ASR

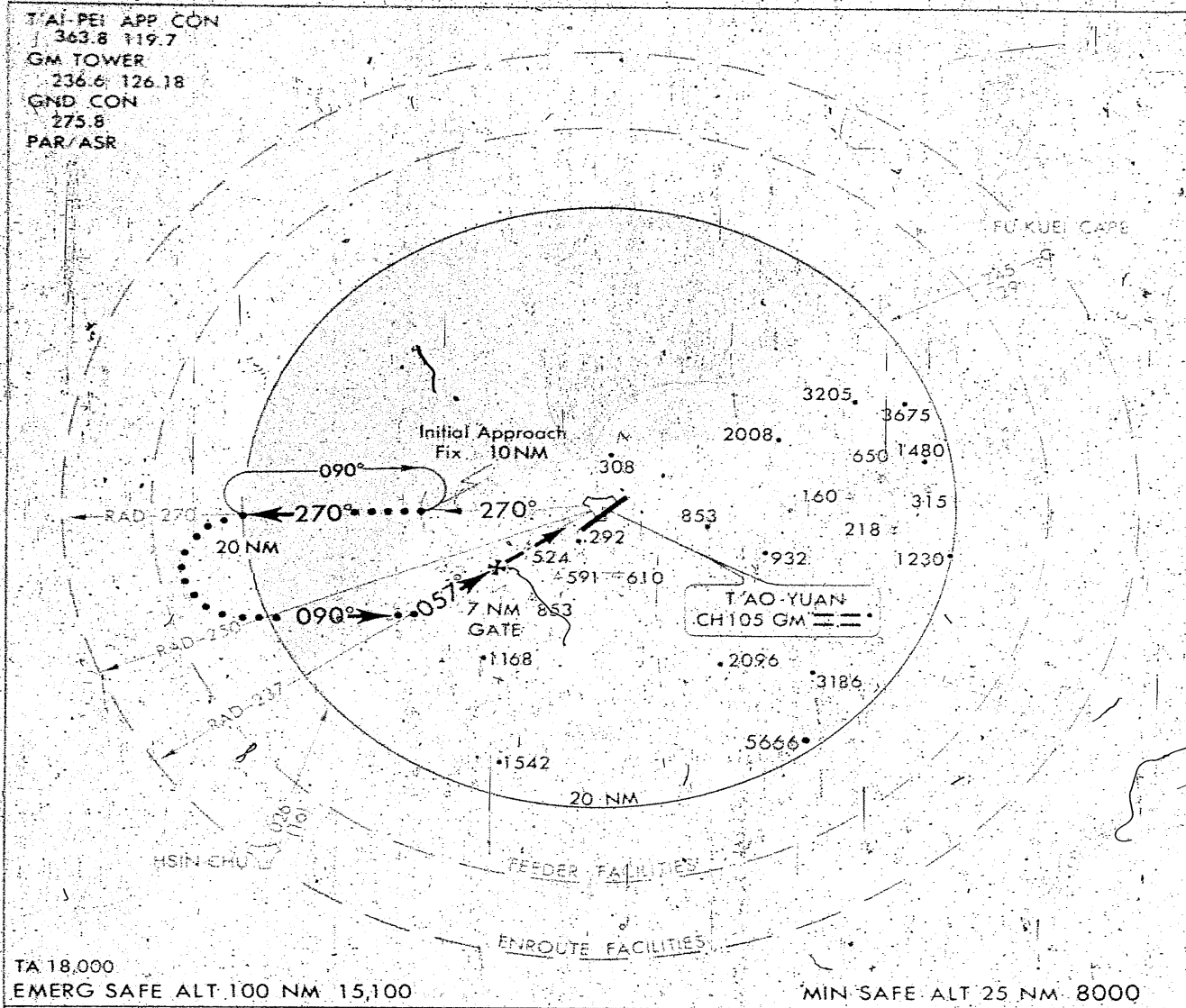

TA 18,000
EMERG SAFE ALT 100 NM 15,100

MIN SAFE ALT 25 NM 8000

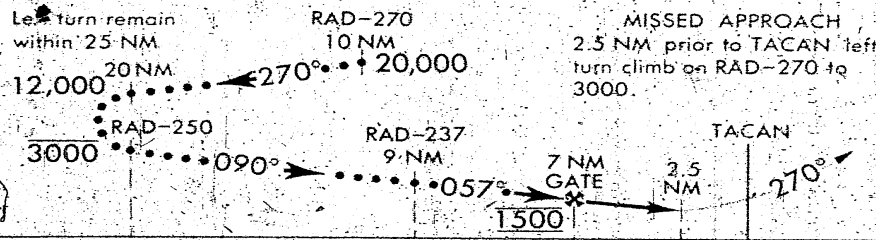

FIELD ELEV 147

LANDING MINIMA	
Straight-in	500 MSL 400-1
Circling *	600 MSL 500-1

* Circling to Northwest only.

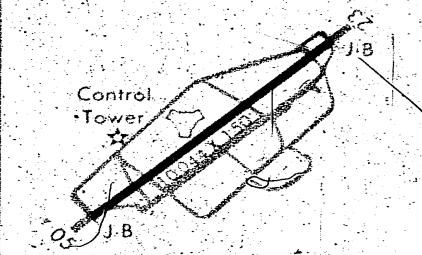

TACAN

25°03'N-121°14'E

T'AO YUAN, TAIWAN, REP. OF CHINA

T'AO-YUAN A/D

TAOYUAN

TAKHLI

TACAN-RWY 18-1

194

JAL 2627 (RTAF)

TAKHLI A/D

TAKHLI THAILAND

TAKHLI APP CON
270.6 363.8 118.1
TAKHLI TOWER
253.5 236.6 126.2
GND CON
275.8
PAR/ASR

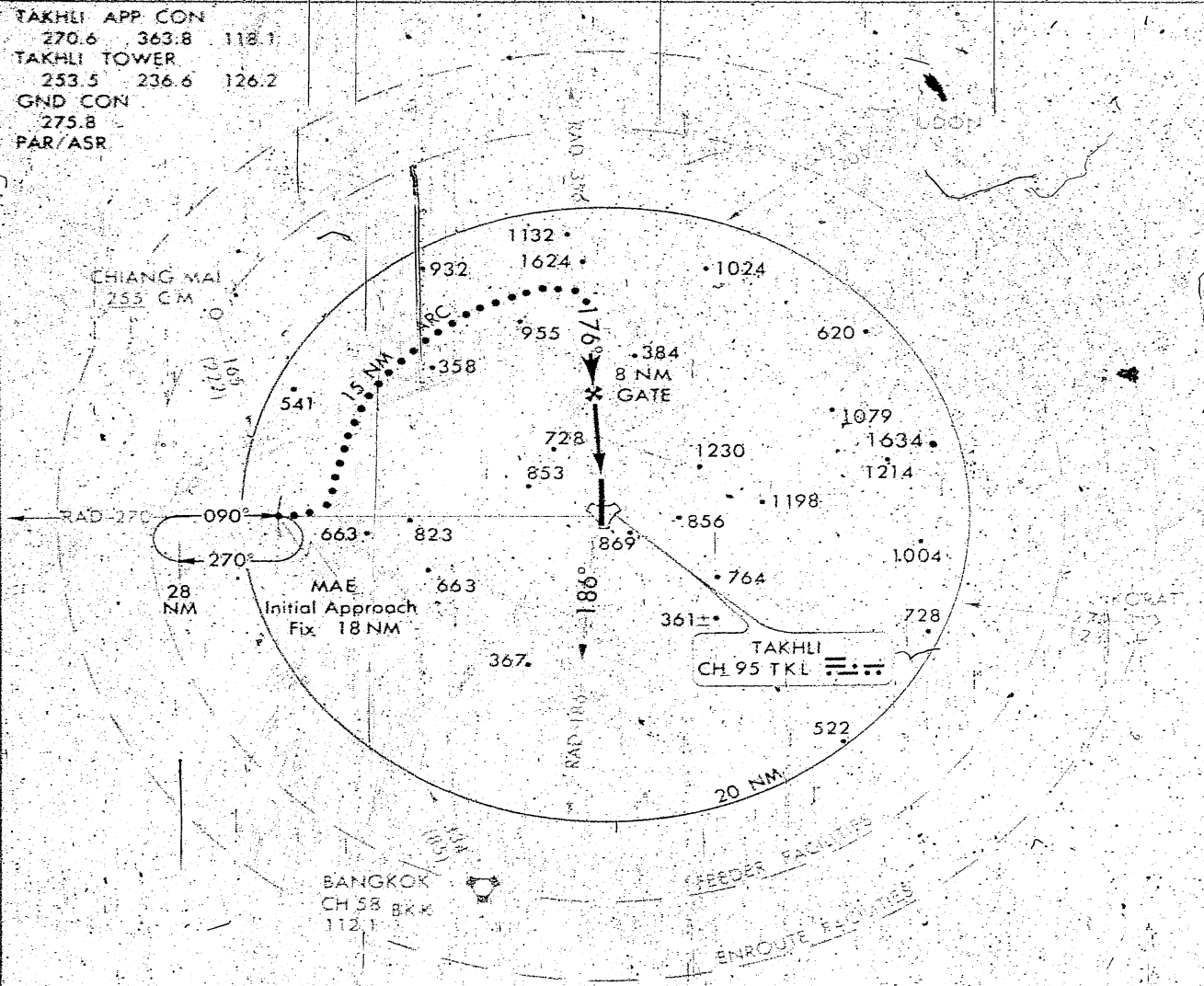

EMERG SAFE ALT 100 NM 8200

MIN SAFE ALT 25 NM 2700

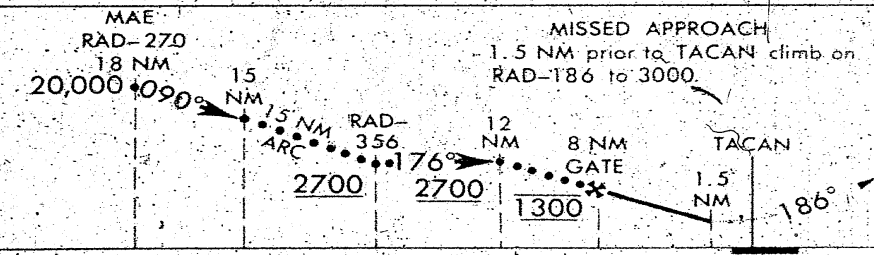

LANDING MINIMA	
Straight-in	400 MSL 300-1
Circling	NOT AUTHORIZED

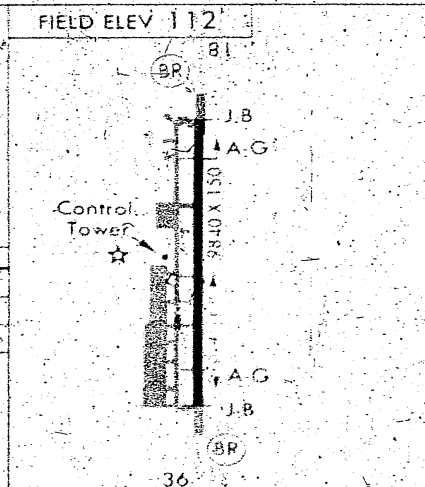

TACAN-RWY 18-1

15°16'N-100°18'E

TAKHLI A/D

TAKHLI

TAKHLI

TACAN-RWY 18-2

JAL 2627 (RTAF)

TAKHLI A/D
TAKHLI, THAILAND

TAKHLI APP/CON
270.6 363.8 118.1
TAKHLI TOWER
253.5 236.6 126.2
GND CON
275.8
PAR/ASR

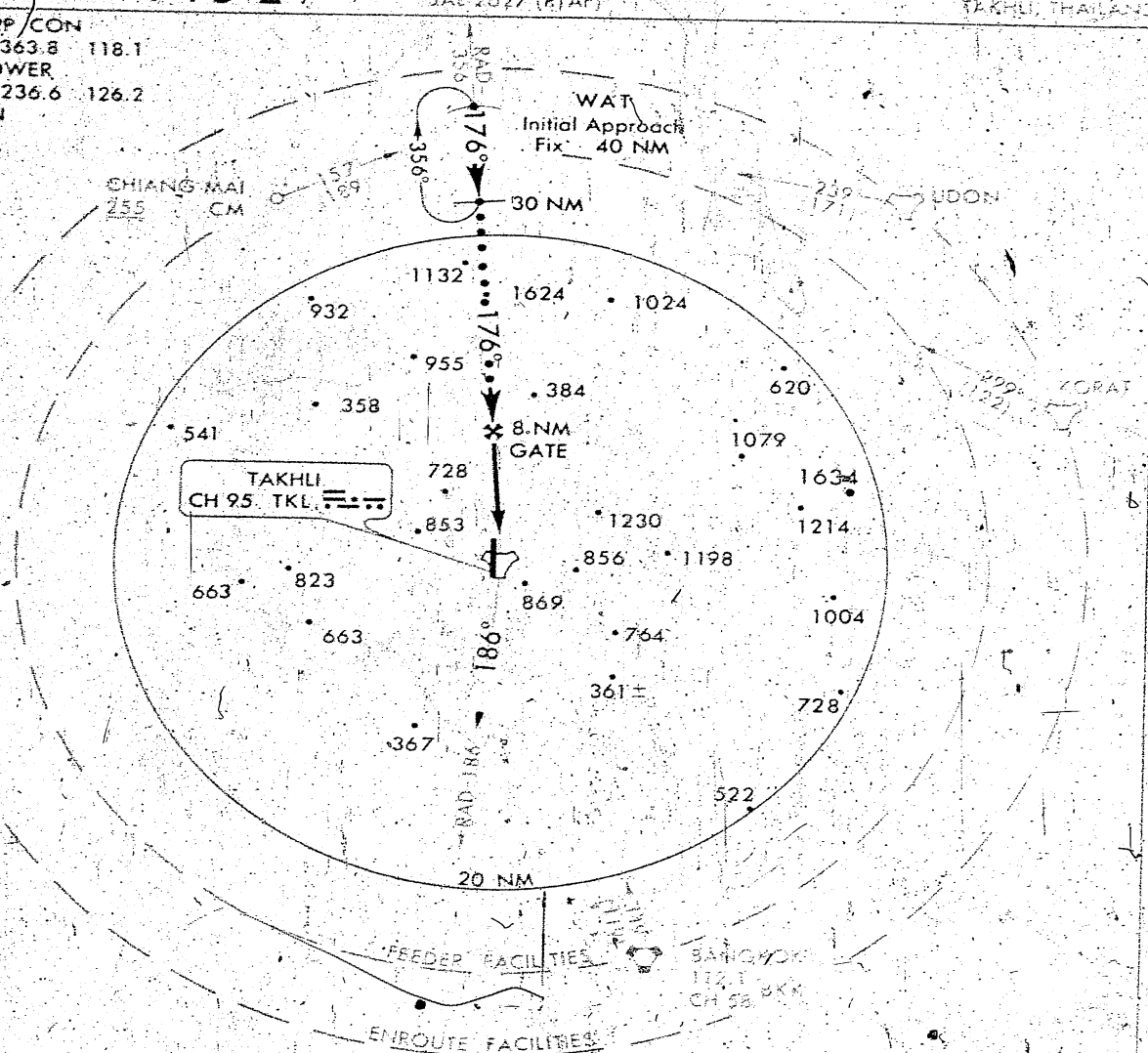

EMERG SAFE ALT 100 NM 8200

MINI SAFE ALT 25 NM 2700

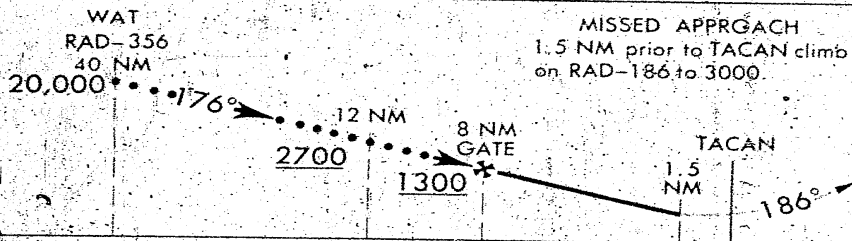

FIELD ELEV 112

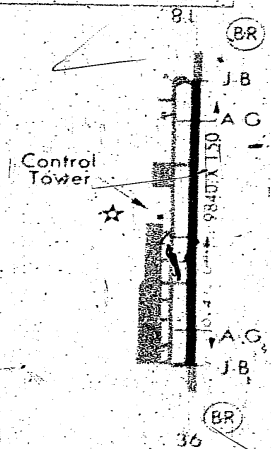

LANDING MINIMA	
Straight-in	400 MSL 300-1
Circling	NOT AUTHORIZED

TACAN-RWY 18-2

15°16'N-100°18'E

195

TAKHLI, THAILAND
TAKHLI A/D

TAKHLI

TAKHLI

TACAN - RWY 36

196

JAL 2627 (RTAF)

TAKHLI A/D

TAKHLI, THAILAND

TAKHLI APP CON
270.6 363.8 118.1
TAKHLI TOWER
253.5 236.6 126.2
GND CON
275.8
PAR/ASR

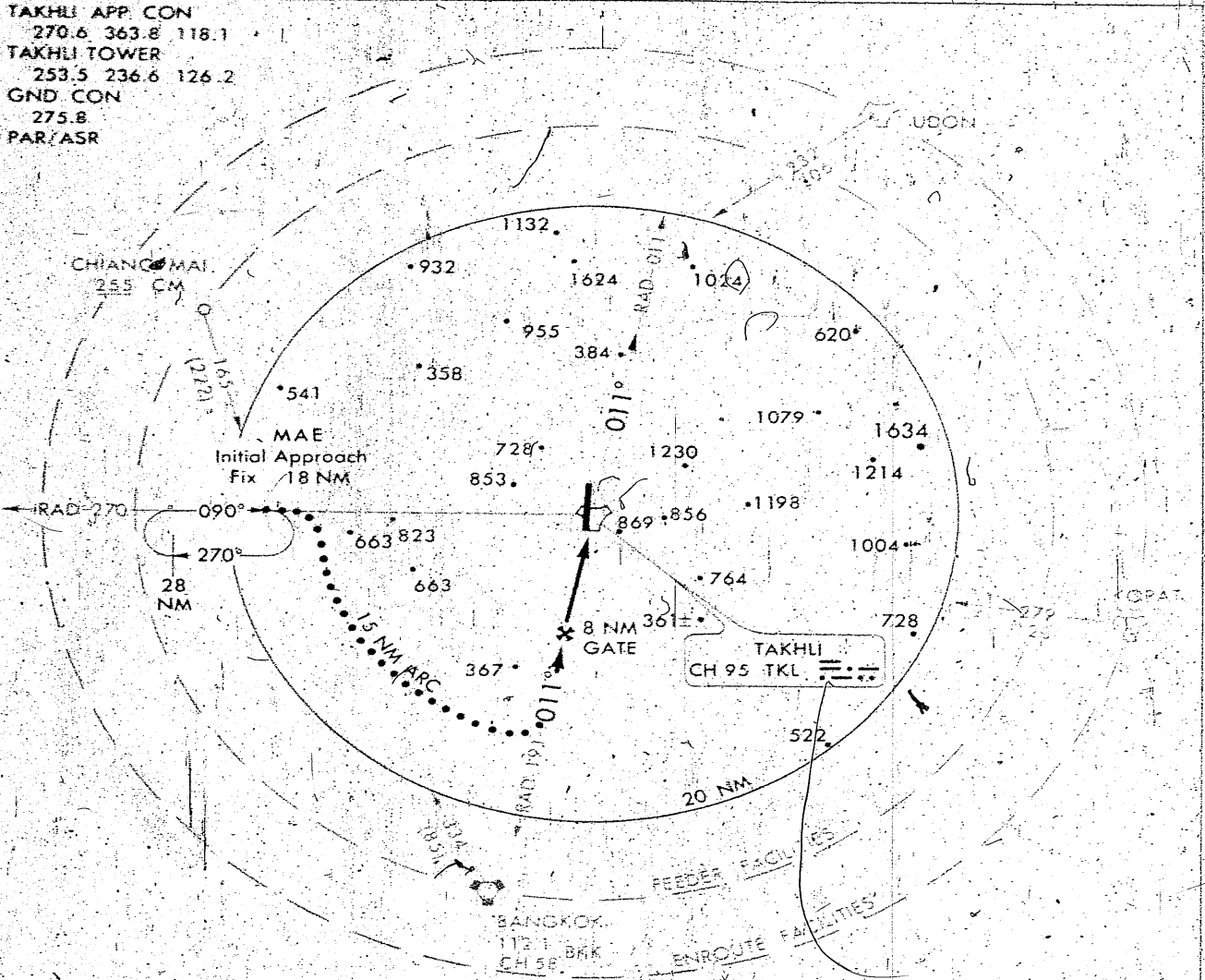

EMERG SAFE ALT 100 NM 8200

MIN SAFE ALT 25 NM 2700

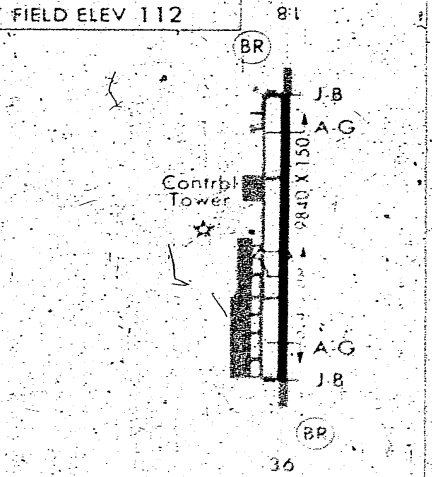
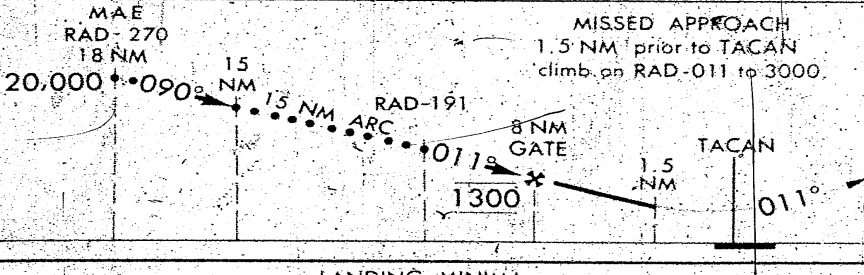

TACAN - RWY 36

15°16'N-100°18'E

TAKHLI - THAILAND

TAKHLI A/D

TAKHLI

Page Denied