

DYD-6173-59  
2 4

FINAL REPORT  
for  
AERIAL EQUIPMENT PROGRAM  
under  
SC 21-54

STATINTL

PROJECT MANAGER

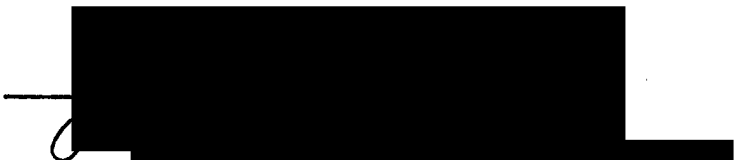

DIRECTOR OF ENGINEERING

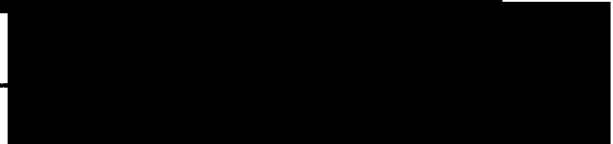

STATINTL

Contributing Authors:



STATINTL

Copy No. 4

Report No. 5490

August 20, 1959

TABLE OF CONTENTS

<u>Title</u>	<u>Page</u>
I. INTRODUCTION . . . . .	1
II. PROGRAM OBJECTIVES . . . . .	2
III. GENERAL HISTORY . . . . .	6
IV. GENERAL EQUIPMENT REQUIREMENTS . . . . .	8
V. DESCRIPTION OF EQUIPMENT . . . . .	11
A. Panoramic Camera System . . . . .	11
1. MK I Tracking Camera . . . . .	11
2. MK I-A Tracking Camera . . . . .	17
B. Viewing and Control System . . . . .	19
1. Hand Control . . . . .	21
2. Memory Unit . . . . .	24
3. Driftsight . . . . .	26
C. Optical Systems for the Camera Configurations . . . . .	28
1. System for A Configuration . . . . .	28
2. System for B Configuration . . . . .	31
3. System for C Configuration . . . . .	33
4. Windows . . . . .	36
D. Significant Auxiliary Equipment . . . . .	37
VI. CONCLUSIONS . . . . .	43
VII. APPENDIX . . . . .	46
A. List of Pertinent Publications . . . . .	46

LIST OF ILLUSTRATIONS

<u>Title</u>	<u>Page</u>
I. PANORAMIC CAMERA . . . . .	12
II. PANORAMIC CAMERA - ELECTRICAL AND MECHANICAL COMPONENTS. . . . .	13
III. PANORAMIC CAMERA - FILM COMPARTMENT. . . . .	15
IV. PANORAMIC CAMERA - FILM FORMAT . . . . .	16
V. PANORAMIC CAMERA - SCANNING DIRECT AND LIMITS . . . . .	18
VI. VIEWING AND CONTROL SYSTEM . . . . .	20
VII. HAND CONTROL . . . . .	22
VIII. MEMORY UNIT . . . . .	25
IX. DRIFTSIGHT . . . . .	27
X. 24" f/8 LENS . . . . .	29
XI. 36" f/10 LENS . . . . .	32
XII. C SYSTEM . . . . .	34
XIII. OPTICAL ARRANGEMENT, COLLIMATOR . . . . .	39
XIV. 100" COLLIMATOR. . . . .	41
XV. 300" COLLIMATOR. . . . .	42

I. INTRODUCTION

This report is a brief summary of the activities carried out by The Perkin-Elmer Corporation in its participation in the Aerial Equipment Program under SC 21-54. It presents the primary objective of this activity, gives the historical developments, and describes the equipment supplied by this corporation. Technical advancements which resulted are also discussed.

II. PROGRAM OBJECTIVES

This firm was delegated certain areas of responsibility in optical instrumentation. The primary purpose of this optical instrumentation was to supply photographic reconnaissance equipment for high altitude surveillance. The time urgency of producing operational equipment had a major influence in determining the philosophy and method of approach. The philosophy was to obtain an operational capability at the earliest possible time and with the utmost security. This operational capability was to include equipment which would give maximum performance possible for the surveillance mission. It was apparent that the vehicle for the mission would be available considerably in advance of the more sophisticated optical systems required for the ultimate capability. These considerations formed the basis for a decision to supply several equipment packages, each of which was to be a definite improvement over the preceding one.

The first equipment package, which may be considered Phase I, was based on an effort to obtain an immediate reconnaissance capability. It consisted of modifying existing equipment available to give improved performance.

It was obvious at the outset that existing photographic equipment, even with a judicious amount of carefully executed optical refinement, would not be capable of achieving the performance levels that could be accomplished by equipment designed and manufactured specifically for this intended mission. That recognition led to the formation of Phase II. Phase II consisted of a program to design and manufacture optics which would replace the optics used in Phase I.

Phase II, however, was also an intermediate step. It did not

represent the maximum general reconnaissance performance desired. To obtain maximum general reconnaissance capability, it was felt that equipment would have to be designed for this specific mission. It was obvious that the achievement of such an objective would require more time than that allowed for the previous phases. Therefore, it was decided that specific new equipment would be developed concurrently with the other phases. This program constituted Phase III. The resulting equipment would eventually replace the Phase I and II units for general reconnaissance use.

Finally, Phase IV would consist of equipment whose use would be highly specialized. It was envisioned that equipment built under this phase might well have to advance the state of the art to perform the specialized function. To advance the state of the art, new auxiliary equipment was necessary and had to be constructed to make a complete operational unit. Moreover, the design and manufacture of this equipment had to be undertaken on a crash schedule.

Equipment built under this phase would be used for special reconnaissance missions based on information from Phase III equipment. It was felt that in this way both requirements, that of immediate availability and that of maximum capability, could best be accomplished.

The tables on the following two pages describe the equipment and coverage intended for these phases. The A<sub>1</sub> Configuration satisfied Phase I, the A<sub>2</sub> Configuration corresponded to Phase II, Phase III was initiated with the B Configuration, and it was the purpose of the C Configuration to provide Phase IV.

CAMERA CONFIGURATION CHARACTERISTICS

Configuration	Tracker	A1		A2	B			C		
		M1	M2		M1	M2	M3			
Mission Purpose	Auxiliary information for all configurations.	Mapping and medium scale military industrial intelligence	Medium scale military industrial intelligence	Medium scale military industrial intelligence	Medium scale military industrial intelligence	Spotting camera military industrial intelligence	Spotting camera military industrial intelligence	Spotting camera military industrial intelligence	Spotting camera military industrial intelligence	Spotting camera military industrial intelligence
Focal Length	3"	6"	24"	24"	36"	36"	180"	180"	180"	180"
Range-Photo Flightline Miles	5000 stereo	5000 stereo	1080 stereo	3250 stereo	1725 stereo	2875 stereo	500 stereo spot photos	3500 single line	1750 double line	
Area Coverage	Transverse horizon-to-horizon. Flt. path - 10 ml.	20 x 20 miles	5 x 10 miles	5 x 10 miles	6.6 x 6.6 miles	6.6 x 6.6 miles	1 x 1 mile	1 x 1 mile	1 x 1 mile	
Angular Coverage	42° along flt. path X 180° transverse	186° total 74° per camera	115° total 41° per camera	115° total 41° per camera	Hor.-to-hor. 28° per exp	86° total 28° per exp	120° total 4° per exp	120° total 4° per exp	120° total 4° per exp	
Ground Scale Vertical Photo	1:280,000	1:140,000	1:35,000	1:35,000	1:23,300	1:23,300	1:4670	1:4670	1:4670	
Ground Resolution Vertical Photo	18 ft.	18 ft.	4 ft.	4 ft.	2.5 ft.	2.5 ft.	3/8 ft.	3/8 ft.	3/8 ft.	
Uses of Information	Provide cont. hor. to hor. cov. of mission. Mapping & med. scale military industrial intelligence.	Maps for location and identification of industrial installations	Identification of industrial installations	Identification of industrial installations	Identification and analysis of installations for technical and economic information	Identification and analysis of installations for technical and economic information	Detail analysis of installation for technical and economic information	Detail analysis of installation for technical and economic information	Detail analysis of installation for technical and economic information	

# CAMERA CONFIGURATION LATERAL COVERAGE

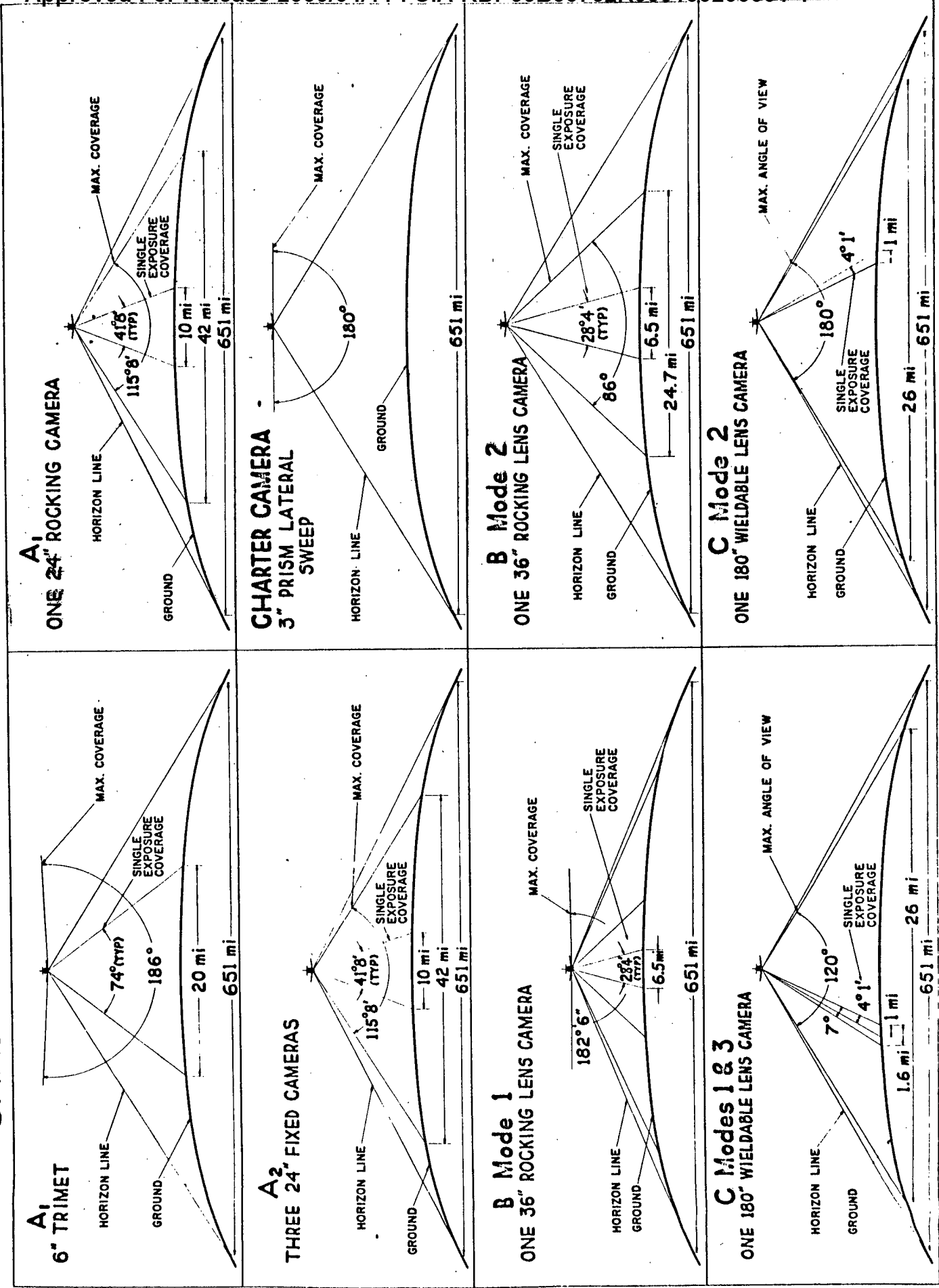



III. GENERAL HISTORY

To achieve these objectives within the security requirements, an organization tailored to serve this program was necessary. When the nature of the task is considered and the difficulties under which the program was undertaken (short delivery and rigid security restrictions) are recognized, the magnitude of the job of liaison becomes apparent.

Perkin-Elmer was given primary responsibility for a major portion of the Aerial Equipment Program. In January, 1955, this Corporation formed a separate division which became known as the Projector Division. Facilities were located in an office in Stamford, Connecticut, apart from the main headquarters and facilities of the parent Corporation, and [REDACTED] Vice President of the Corporation, took personal responsibility for the STATINTL Projector Project. To safeguard the high security aspects of the program, the staff of this office was kept to a minimum.

The primary functions of the Projector Office were controlling, defining, scheduling, coordinating, expediting, and integrating the various phases of the program. Customer contact was made through this office beginning February, 1955.

The office was fully protected and equipped with private, monitored telephone lines. The method followed was to conduct business on an informal and personal basis; on this basis to convey all essential information without revelation of the program, its purpose, or other secure information.

The prime contract with the customer was subdivided by this office to contracts with various subcontractors (some of which were specified by the customer), and with Perkin-Elmer. Throughout the program, suppliers' meetings aided in detailing project planning, served to coordinate broad planning efforts of the various contractors, and helped solve many of the current

problems.

A facility, known as Plant No. 9, was established in Pasadena, California, in which a subcontractor carried on its portion of the program. As the program progressed, a test site was established by the customer, to serve as a facility at which the equipment could be tested.

STATINTL

Close coordination with [REDACTED] of SPICA made it possible to manufacture optics from design data within the shortest possible lead times. SPICA, under subcontract to Perkin-Elmer, was responsible for the design of the new optical systems which were used in the program. Besides design and performance specifications themselves, the scope of the subcontract included some supervision of the construction of the lenses and cameras to insure that design specifications would be met.

Frequently technical problems arose which, it appeared, were certain to result in compromise of capability or delay. However, by careful analysis and diligent effort, the philosophy originally laid out was maintained throughout the program.

IV. GENERAL EQUIPMENT REQUIREMENTS

The entire photo reconnaissance system equipment was planned and tailored to meet the needs of the mission. Mission requirements made it essential to:

- (a.) Obtain a continuous photographic recording which would give maximum, high quality coverage of the general area being surveyed. To satisfy the requirements for monitoring the mission, a panoramic tracking camera was designed and delivered.
- (b.) Provide a means for an operator to visually observe this area and equip that operator with a means of pointing special photographic equipment. To satisfy the requirements for operator viewing and control, a periscope-type viewer, hand control device, and memory-computer device were designed and delivered.
- (c.) Provide a number of camera configurations for the survey and spotting functions. To satisfy the need for high acuity photo reconnaissance, four camera configurations were developed. These were known as the A<sub>1</sub>, A<sub>2</sub>, B and C Configurations.

It was also necessary to test and maintain the equipment in plant and in the field. For this purpose, special support equipment was also necessary. This equipment was considered in two groups: factory development and test equipment, and field test and support equipment.

Contrary to the philosophy of most contracts, in which equipment designed is finally turned over to the using agency, the equipment under

this program was designed to be operated and/or serviced by specially trained factory personnel. A separate program was established to permit proper training of personnel while the equipment was being manufactured. This approach resulted in a considerable saving of time in providing operational equipment and also maintaining high reliability in the use of this equipment.

The following chart lists the specific equipment assigned to Perkin-Elmer, and describes the sub-contracting organization.

This report does not discuss the mechanical aspects of the A, B, and C Configurations, which are included in the final report submitted to the Government by Hycon Mfg. Co.

**EQUIPMENT ASSIGNED TO P-E**  
(And Sub-Contracting Organization)

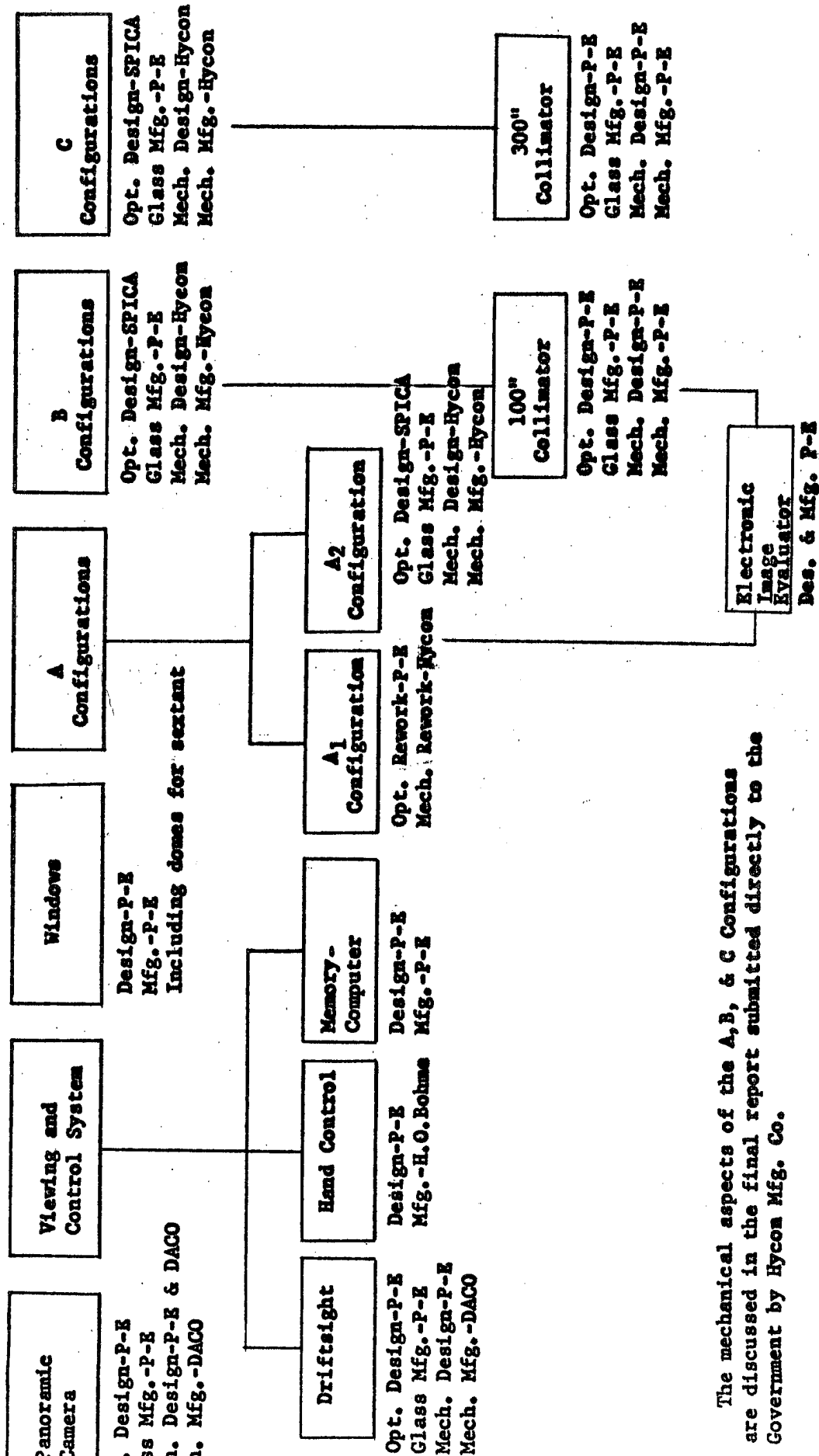

The mechanical aspects of the A, B, & C Configurations are discussed in the final report submitted directly to the Government by Hycon Mfg. Co.

V. DESCRIPTION OF EQUIPMENT

A. Panoramic Camera System  
(Fig. No's. I, II, III, IV and V)

1. Mark I Tracking Camera

It was clear at the inception of this program that a panoramic monitor would be needed to photographically record the flight path. A primary requirement was to provide a camera of high image quality to give horizon-to-horizon coverage with 60% overlap of the entire flight path. A further requirement was to provide entirely automatic operation.

The resulting panoramic camera, often referred to as the Data Camera or Tracking Camera, proved to be a very useful and important instrument. The unit employed scanning principles to obtain successive 180° panoramic photographs and had the capability of a 60% stereo overlap. It was fully automatic in operation and had a film capacity large enough to provide horizon-to-horizon photographic coverage for a complete mission. Completely self contained and requiring only a 28-volt dc power source, it weighed less than 53 pounds fully loaded. No special accessories were needed; image motion compensators, intervalometers, aperture controls and other devices necessary to obtain sharp, clear images were built into the instrument. The entire field was scanned through a small 5-inch diameter dome. The resulting photograph, on 70mm film, had a 2.47 by 9.425-inch format. Data presentation which appeared on each frame consisted of a level and time indicator.

Under close Perkin-Elmer direction throughout the course of the contract, a portion of the design (in details only) plus drafting, manufacturing, assembly, and test was subcontracted to DACO Instrument Company. A rigid delivery schedule was established with DACO which was satisfactory to the program.

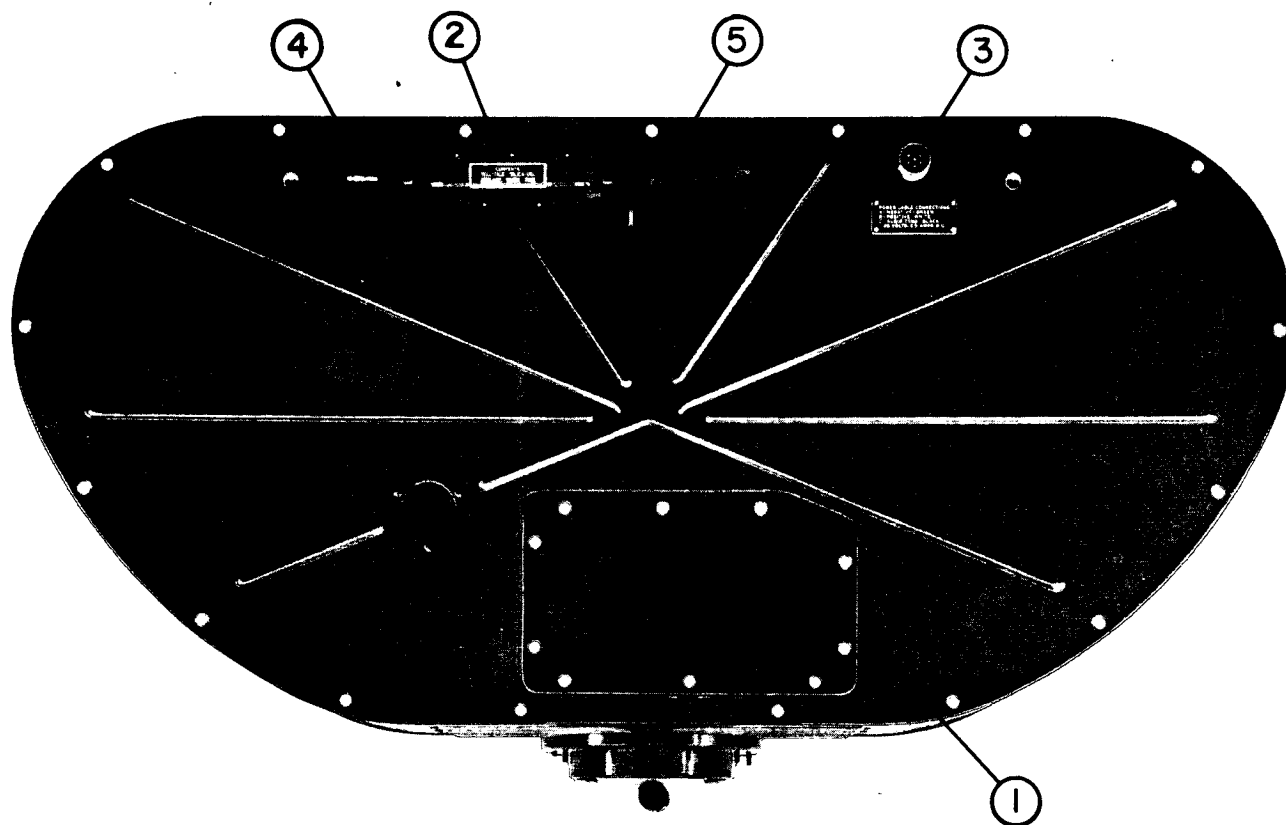

- |                                  |                                   |
|----------------------------------|-----------------------------------|
| 1. Access Cover for Change Gears | 4. Dry Gas Supply Hose Connection |
| 2. Desiccator                    | 5. Vacuum Pump Hose Connection    |
| 3. Receptacle                    |                                   |

Figure I. Mark IA Tracking Camera, Showing Forward Cover

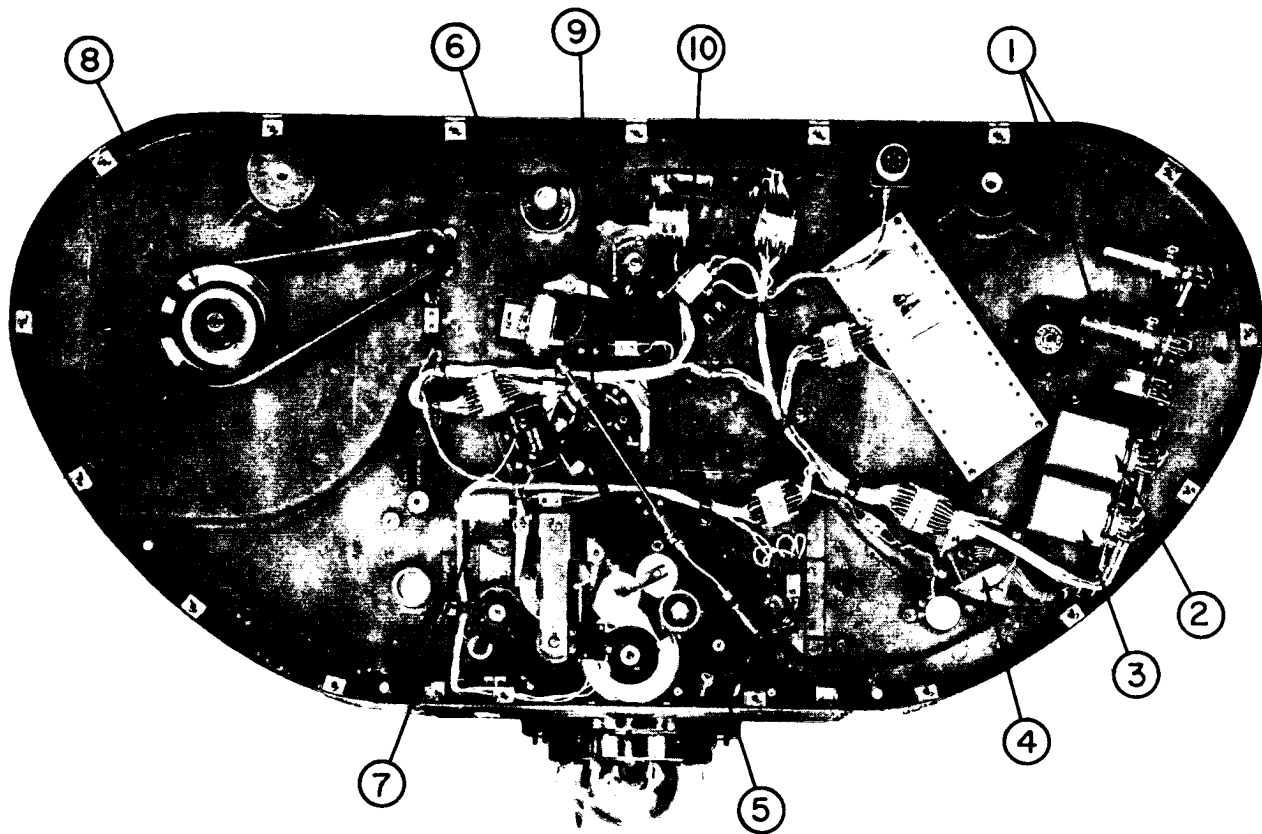

- |                                      |   |
|--------------------------------------|---|
| 1. Thermal Relay (H802, H803)        | 6. Metering Solenoid (L804)             |
| 2. Relay (K811)                      | 7. Scan Solenoid                        |
| 3. Relay (K810)                      | 8. Take-up Clutch                       |
| 4. Latching Relay (K812)             | 9. Drive Shaft for Programmer Mechanism |
| 5. Aperture Programmer Gear Assembly | 10. Metering Cam Switch (S806)          |

Figure II. View of Camera Showing Electrical and Mechanical Components



problems:

- (a.) The rigid delivery schedule did not allow enough time for thorough prototype debugging tests prior to operation, and
- (b.) due to the necessary security measures, project engineers who designed the equipment did not have cognizance of the ultimate end-use of the equipment. This lack of end-use knowledge resulted in slight over-design in some functions of the camera.

The degree to which these problem areas were anticipated is questionable. The fact is that the lack of thorough prototype debugging resulted in specific and definite problems which appeared later in the program.

One prototype and 20 production units were built and supplied to the field. After the units had been in the field for some time, it became apparent to field engineers that certain minor changes could be made in the field to improve operation and better serve the end-use. It was found, for example, that bushings in the scan prism mechanism had become worn and had to be replaced (by a factory representative) with a more lasting type of bushing. Banding occurred and resilient couplings in the drive mechanism were incorporated to absorb vibrations which were contributing to banding.

It should be made clear that since this was a new, unconventional and highly secretive application, a number of unknowns would be introduced into the problem and that these unknowns might seriously affect the performance of the equipment. Decisions, however, had to be made, and it is a recognized fact that these decisions did affect equipment performance, both favorably and adversely. In some instances these decisions forced a

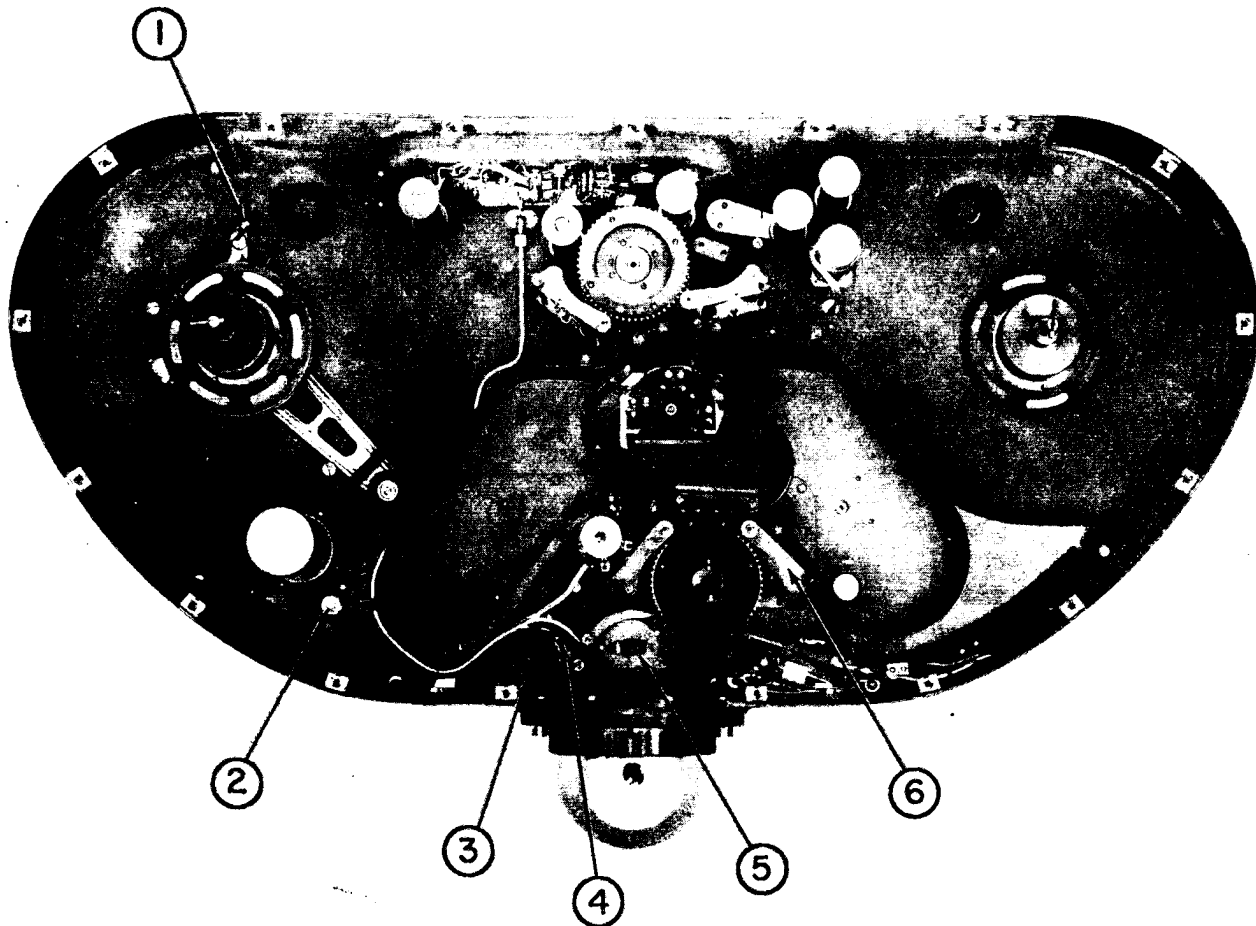

- |                             |                     |
|-----------------------------|---------------------|
| 1. Brake Tension Adjustment | 4. Retracting Lever |
| 2. Clock Dimmer (R830)      | 5. Filter Selector  |
| 3. Aperture Cam             | 6. Sprocket Gate    |

Figure III Film Compartment of Camera With Film and Spools Removed

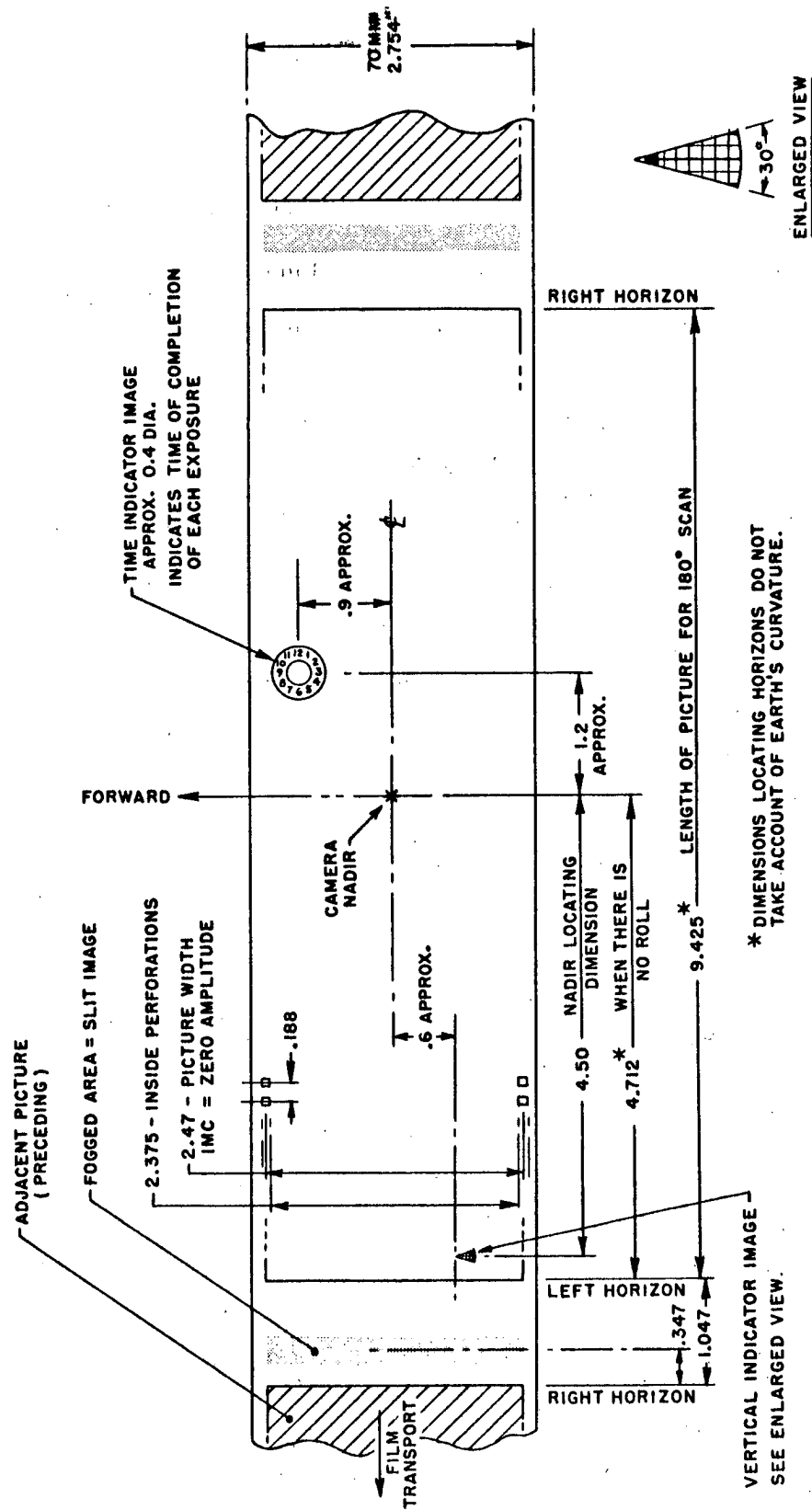

Figure IV. Film Format

breakthrough in the state of the art and resulted in performance far above expectations.

In other instances these decisions caused results which required corrective action. With regard to the panoramic tracking camera, for example, a decision was made to incorporate an integrating type system for the automatic control apparatus. This decision was based upon an assumption of environmental conditions, and while it was a logical decision, it was wrong. Because the automatic exposure system was an integrating system, it was influenced by underlying cloud cover and, therefore, did not give satisfactory results. Until it was possible to make a major overhaul of the cameras (for a period of approximately two years) it was necessary to operate the cameras with fixed slit aperture. Fortunately, the camera was designed to provide this alternate method of operation.

Some method of exposure control was desirable. However, limited field facilities did not permit incorporation of an alternate system into the camera. The first opportunity to make this conversion presented itself in the spring of 1958. A retrofit program was then undertaken. During this retrofit program changes were made in the camera, converting the Mark I cameras to what was then designated as the Mark IA.

## 2. Mark IA Tracking Camera

Mark I cameras in the field were returned to the factory in 1958 on a scheduled basis, overhauled and tested, and returned to the field. By returning only a few cameras at a time for modification, the customer was assured of having tracking camera capability in the field at all times.

The program had two purposes; that of overhauling the Mark I cameras which had by then accumulated a great number of hours of use, and that of incorporating into these cameras those changes which would make them

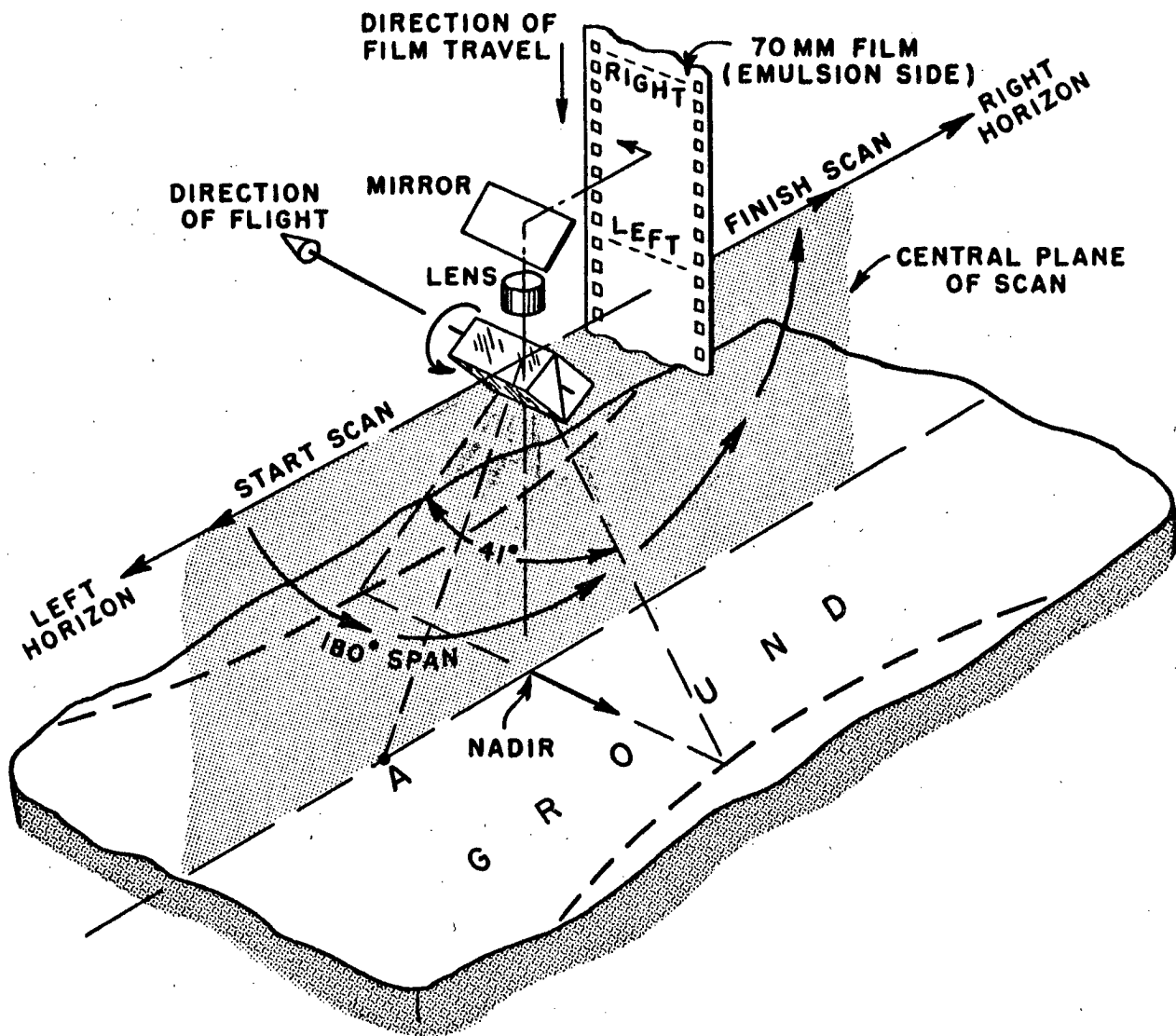

Figure v, Scanning Direction and Limits

functionally more reliable or equip them for improved performance.

A pre-programmed cam-activated exposure control was designed and installed, to provide a suitable exposure control for the mission. The IMC capability of the camera, which was found to be unnecessary for this particular mission, was removed. Stray light was a problem, and prism masks were added to prevent stray light effects. Moreover, it was realized that the operation could be improved by changing the electrical wiring, and several wiring changes were incorporated. Circuit changes were made and the substitution of improved sealed relays were added.

While the overhauled Mark IA cameras were being tested (and in some instances after they were deployed into the field), several malfunctions developed which required field retrofit programs to correct. Again, this was due to a debugging time limitation. Improvements in the metering mechanisms insured more positive latching action and higher duty switches and resistors were installed to reduce arcing and welding of contacts.

The Mark IA modification program added many hours of reliable operation to the equipment, and incorporated features to improve performance. Although a statistical study has never been undertaken to determine the actual resolution of either the Mark I or Mark II units, it is estimated that performance between 25 to 45 lines per mm AWAR has been recorded on film. The resolution levels obtained were affected by atmospheric conditions, image contrast, and similar variables.

B. Viewing and Control System  
(Fig. No. VI)

To make the reconnaissance system effective, it was necessary to (1) equip the operator with a viewing device to observe the terrain and areas of general interest over which he was operating and (2) to equip him with a control device to control the various modes of operation of the different

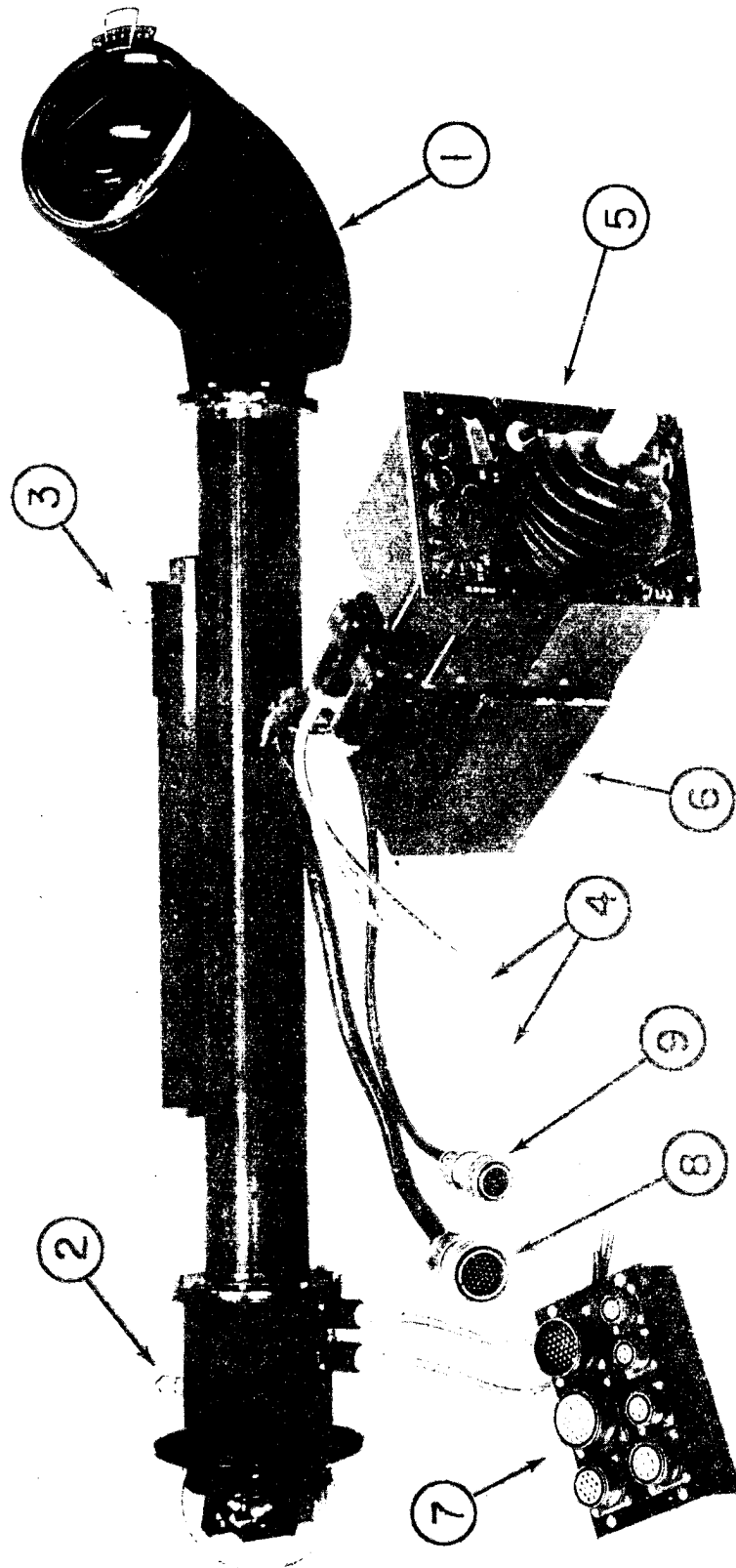

- |                                       |                    |                       |
|---------------------------------------|--------------------|-----------------------|
| 1. Scanning Periscope<br>(Driftsight) | 4. Flexible Shafts | 7. Junction Box       |
| 2. Desiccation Fitting                | 5. Hand Control    | 8. Hand Control Cable |
| 3. Desiccation Fitting                | 6. Memory Unit     | 9. Memory Unit Cable  |

Figure VI. Periscope, Hand Control and Junction Box

camera configurations.

The need for a viewing device was readily solved by developing a suitable scanning periscope. The need for a control unit, however, proved more of a problem. Due to the difference in complexity of the control functions (the C configuration required a more complex control than the A or B configurations) the original plan was to provide two different hand control units. The first hand control, which would be employed with either the A or B configurations, was to be a relatively simple device. Basically it would permit a selection of the various modes of operation of these configurations, as well as direct the line of sight of a periscope type viewing device.

The second and more complicated hand control for the C configuration was to provide V/H information, a correction for drift, and a computer. The computer would, in effect, be a memory unit which would enable the operator to pre-select targets of interest observed through the drift-sight and store this target information in the computer. When the vehicle was in an optimum position for photography, operation of the C configuration spotting cameras would be automatically initiated.

To be consistent with the number of C configurations anticipated, it was envisioned that six of the more complicated hand controls would be required. After careful consideration of scheduling and production difficulties, it was decided to produce only that hand control which would have full system capability. The computer mechanism - a separate unit - would simply not be attached to the hand control with either A or B configurations.

#### 1. Hand Control (Fig. No. VII)

The Hand Control itself was an electromechanical device which provided basic control of the periscope viewing mechanism and also delivered



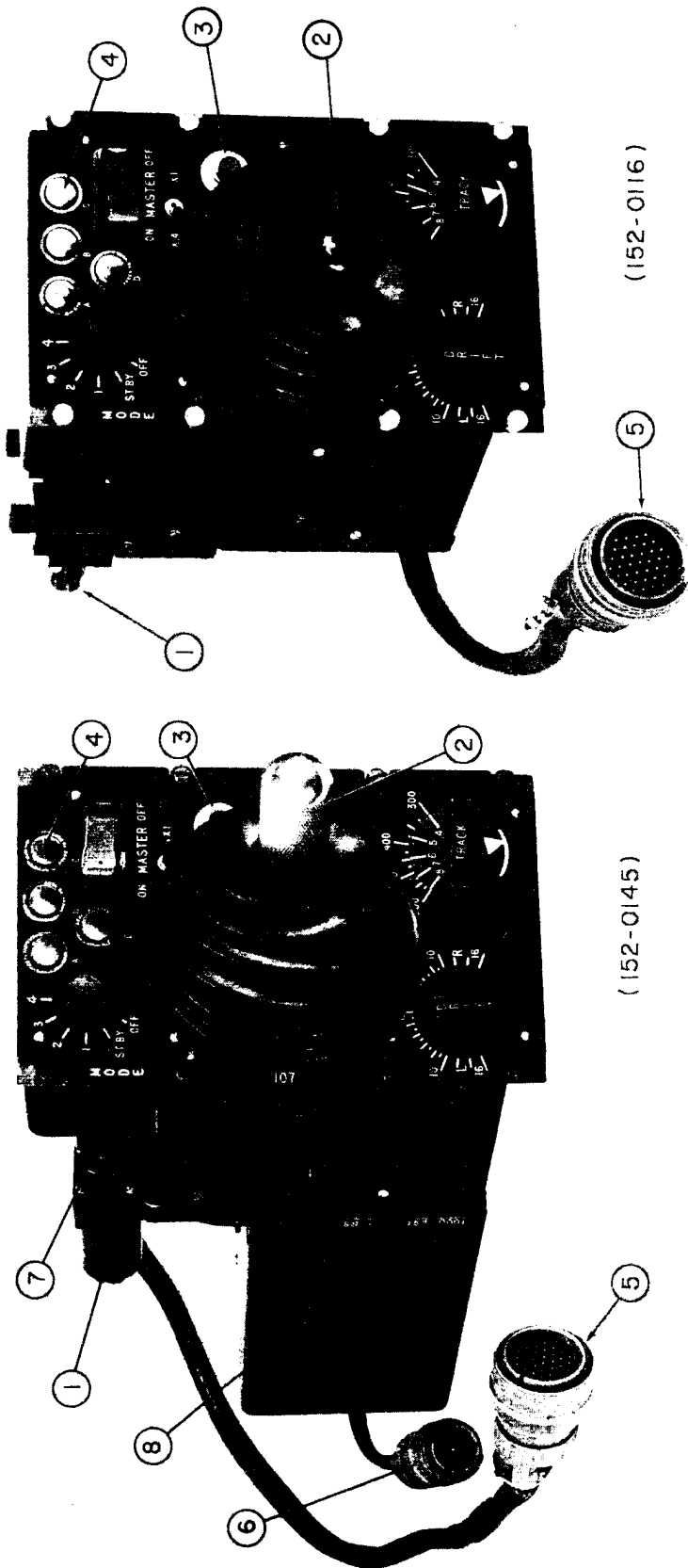

- 1. Periscope Cable Adapters
- 2. Control Handle
- 3. Store Button
- 4. Press-To-Test Lamps
- 5. Hand Control Connector
- 6. Memory Unit Connector
- 7. A + E Boresighting Clutch
- 8. Memory Unit

Figure VII, Hand Control

information to and partially controlled the equipment configurations, as indicated earlier. It was a panel mounted tracking control consisting primarily of a number of gear drive mechanisms and electrical components. It was equipped with both a master ON-OFF switch for energizing related equipment in the over-all system and an OFF-STANDBY-MODE selector switch for turning the automatic tracking feature off, placing it on standby, or selecting any one of three modes of operation. A control handle on the unit provided direct azimuth and elevation control of the periscope line of sight, and a switch permitted changing power (magnification) of the periscope by electrical drive. Adjustments for V/H and for correction of drift were included, as well as a storage switch for energizing the Memory Unit when attached. Finally, several test lamps for fault-proof checking of related equipment were incorporated in the device.

The problem areas which arose were somewhat representative of those encountered in other hardware areas by prime and sub-contractors alike. The design of the Hand Control, for example, was handled by Perkin-Elmer and the manufacturing sub-contracted to H. O. Boehme Company. Scheduling permitted only limited testing and, in general, functional operation was good. When placed in the final operational environment, however, several problem areas arose. High cable friction in the connecting cables between Driftsight and Hand Control resulted from the unusually cold environment, and it was necessary to reroute the connecting cables and substitute more suitable (dry molykote impregnated) cables for the final operation environment. Failures of the protective rubber boot became frequent due to sensitivity of the rubber to the ozone environment. During retrofit program the boots were replaced with specially dipped neoprene ones.

Another significant problem was the fact that production units

lacked adequate means for accurate boresighting due to the lack of knowledge during the design stage of the difficulties of access to the equipment when installed in the vehicle. A subsequent retrofit program made it possible to incorporate a cone-clutch coupling for accurate, convenient, boresighting of those Hand Controls to be used with the C configuration.

2. Memory Unit  
(Fig. No. VIII)

One of the requirements of the viewing and control system was to provide a memory capability to be used in conjunction with the C configuration. It was the purpose of this memory system to provide a means of storing information on the position of the object tracked, and to signal the time at which the object crossed a predetermined position. Since the object, vehicle, or both might be moving at some velocity, and since this equipment delivers the signal to related equipment, allowance was made for lead angle and anticipation of the required signal.

These functions were accomplished by recording the angular position  $\alpha$  (1) of the object, a particular value of tangent  $\beta$  (2) and subtracting that from the V/H of speed altitude ratio until the time when the difference between tangent  $\beta$  and V/H is zero. At that time a signal was delivered to indicate that the object had reached the predetermined position. The lead angle was preset into the unit (before use) to provide the anticipation required to prepare other equipment for the final signal.

The memory-computer unit was mounted directly below the Hand Control from which it received directional information. It was a coding device combining both computing and storage functions in a single unit. It employed the synoptic coding principle, converting information from shaft rotations to pin positions. It was able to store and read-out information with

---

(1)  $\alpha$  represents the angle in a lateral plane perpendicular to the direction of flight.

(2)  $\beta$  represents the forward angle as measured from the nadir.

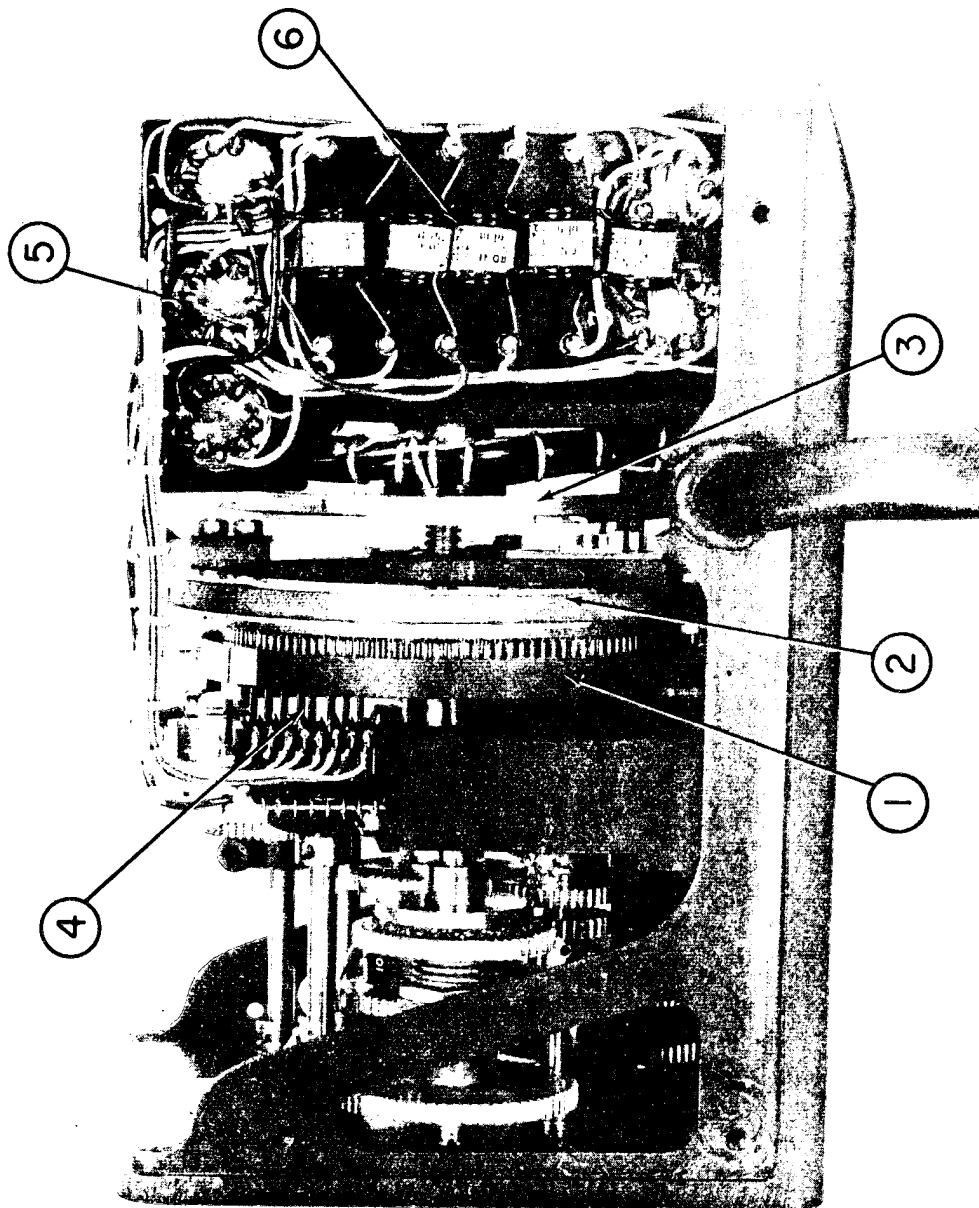

- 1. Pin Disc
- 2. Punch disc
- 3. Code disc
- 4. Code Read-out contacts
- 5. Relays
- 6. Resistors

FIG. VIII. Memory-Computer Unit, Covers Removed

an accuracy of about plus or minus .25% of full scale.

Unfortunately, the C configuration was not operational for this program and therefore the Memory Unit did not have the opportunity to provide its intended function.

3. Driftsight  
(Fig. No. IX)

The periscope-type viewing device was designed to permit the operator to see beneath the vehicle as well as to acquire targets. The periscope, which later became known as the Driftsight, was an in-line tracking device equipped with a dual prism scanning head and display type eyepiece. Scanning in azimuth and elevation was accomplished by a dome-protected rotatable scanning prism at the objective end of the optical system. Cables from the Hand Control provided manual control for azimuth and elevation scanning. By proper calibration with the Hand Control azimuth and elevation coordinates of a selected target could be determined.

A power changer, increasing the power and reducing the field was incorporated. During the change in magnification, the image always remained in focus. The power selector was mounted on the Hand Control panel.

As mentioned earlier, one of the requirements was to use the Periscope in conjunction with the Hand Control to determine velocity/height (V/H) rates as well as drift. V/H rate determinations were made by adjusting the elevation scan rate of the periscope's scanning head until a viewed target did not move with respect to a reticle in the periscope. Direct calibration of the scan rate adjustment permitted determination of the V/H ratio. Drift determination was accomplished by rotating the scanning head to compensate for a horizontal or diagonal movement of the target with respect to a fixed reference.

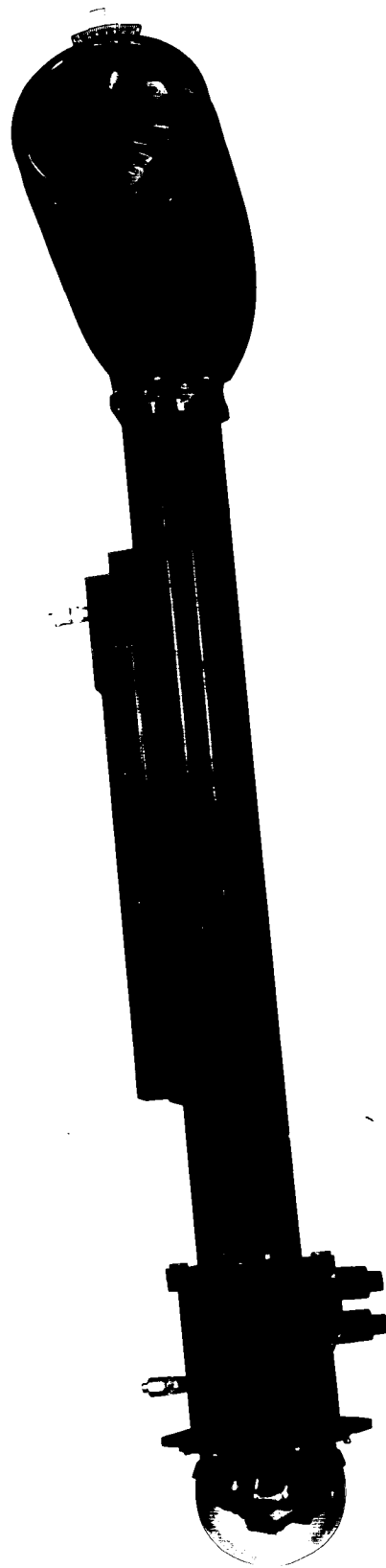

Figure IX DRIFTSIGHT

Design considerations of the periscope were to make it as lightweight as possible, thoroughly reliable and easily installed. These requirements were met by the use of plastic lenses where possible, by incorporation of detachable sections for easy installation, and by use of mechanical linkages instead of servo motors to provide scanning control from the Hand Control. One of the early operational problems of the Driftsight was fogging of the dome. This was eventually rectified with the employment of pre-purified nitrogen as a desiccant and a rather sophisticated desiccating procedure.

In retrospect the design of the unit could have better facilitated installation and maintenance if the designers had been made knowledgeable of the environment. In particular, accommodations would have been provided for a ready detachment of the eyepiece knuckle to facilitate installation, and replacement of the power changer motor for maintenance would have been made possible without removing the instrument from the vehicle.

Early optics manufactured presented a blurred line across the field where the scanning prisms were cemented back to back, and a fairly prominent line where the elements of the roof mirror were cemented together. These components eventually were all replaced to minimize these distractions. In addition, modification of the reticle provided a crow's foot at the center of the field.

### C. The Optical Systems of the Camera Configurations

#### 1. System for A Configuration (Fig. No. X)

To accomplish the initial objective of getting some equipment available in the shortest possible time, a quantity of lenses were supplied to Perkin-Elmer for refinement. The lenses were intended for use in the A

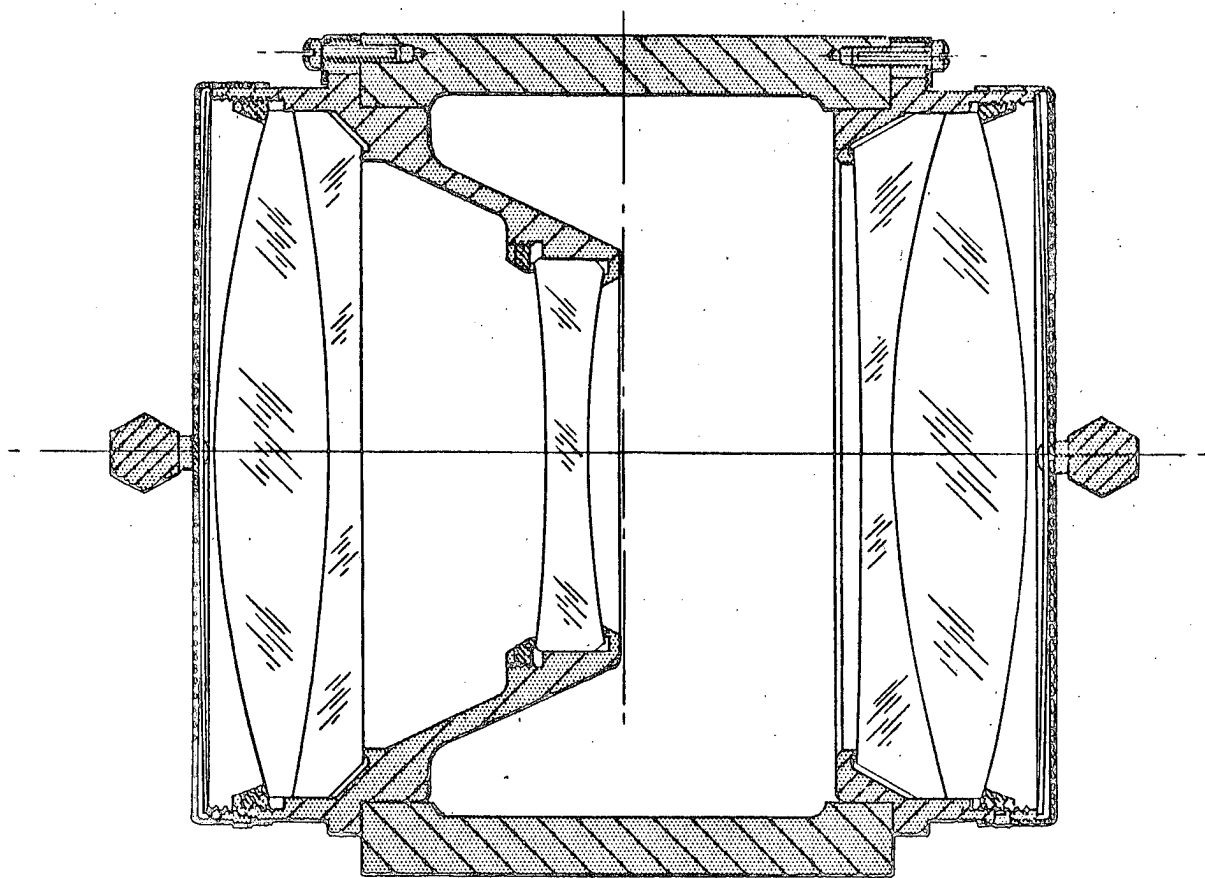

FIG. X. 24" f/8 LENS



configuration. The first to be received were a quantity of six 24" f/6 Bausch and Lomb lenses. Because the castings were of brass and were entirely too heavy for the purpose they were discarded almost immediately. Almost simultaneously a quantity of about 60 Pacific Optical Company 24" f/6 lenses were provided. Under Dr. Baker's direction these lenses were evaluated and reworked. Preliminary examination showed that all the lenses suffered inaccurate centering to some degree, making it necessary to rework the cells. After this action, a program of respacing various elements and modifying the radii of two of the curves was initiated. These modifications resulted in a disappointingly small improvement in performance. A further modification was the application of an aspheric figure to one of these surfaces in order to maximize the on-axis performance. The improvement was considerable, bringing the resolving power from about 28 lines per millimeter up to about 48 lines per millimeter in the immediate vicinity of the center of the field. The change at larger field angles, however, was exceedingly small. A final modification program was initiated to modify the lens to improve the field performance. These modifications were performed on a prototype basis. When sufficient improvement was realized, production began on the quantity of 60.

Concurrent with the stop-gap program of reworking the 24" f/6 (Pacific Optical) lenses, a program was established for producing an entirely new lens (Phase II). Based on Dr. Baker's design, a prototype of a 24" focal length and f/8 aperture lens was built. After considerable testing and some modification, the prototype was found to be acceptable. At this point the new lens was placed in production and the reworking of the Pacific Optical lenses was halted. (About 40 Pacific Optical lenses had been completed by that time). A program of field replacement of the Pacific Optical

lenses was then introduced.

A quantity of red and yellow filters to be used with the 24" lenses were also supplied. These were examined and filters which would not reduce the resolution capability of the lens were selected. Unfortunately, it was found that there were not enough filters of sufficient quality to compliment the quantity of lenses being produced. As a result, additional filters had to be manufactured.

2. System for B Configuration (Fig. No. XI)

A lens design was originated by Dr. Baker which was to be used in the unit known as the B Configuration (Phase III). This was a 36" focal length f/10 lens. As the design became available, glass was ordered and the unit was placed in production. Six units were originally planned. During the production phase some problems with the shutter developed by Hycon arose and a new drawer-shutter was developed. It was decided that this new drawer-shutter should be incorporated. This, in turn, required the production of new castings to accommodate the new shutter.

Filters also caused difficulty. A yellow filter was necessary and a dichroic coating was placed on the inner surfaces of a 36" lens to provide the yellow filter. Due to certain technical reasons, difficulty was encountered in selecting an appropriate coating. A requirement later arose for a red filter, and it was necessary to add a glass filter, in conjunction with the existing dichroic coating to produce an equivalent red. Due to clearance problems these glass filters had to be made thinner than was desirable.

The design of the 36" f/10 lens required its use with a lightweight elliptically shaped mirror. Due to the extremely tight tolerances, production of this mirror was very difficult. Considerable engineering was required before a satisfactory mirror was produced.

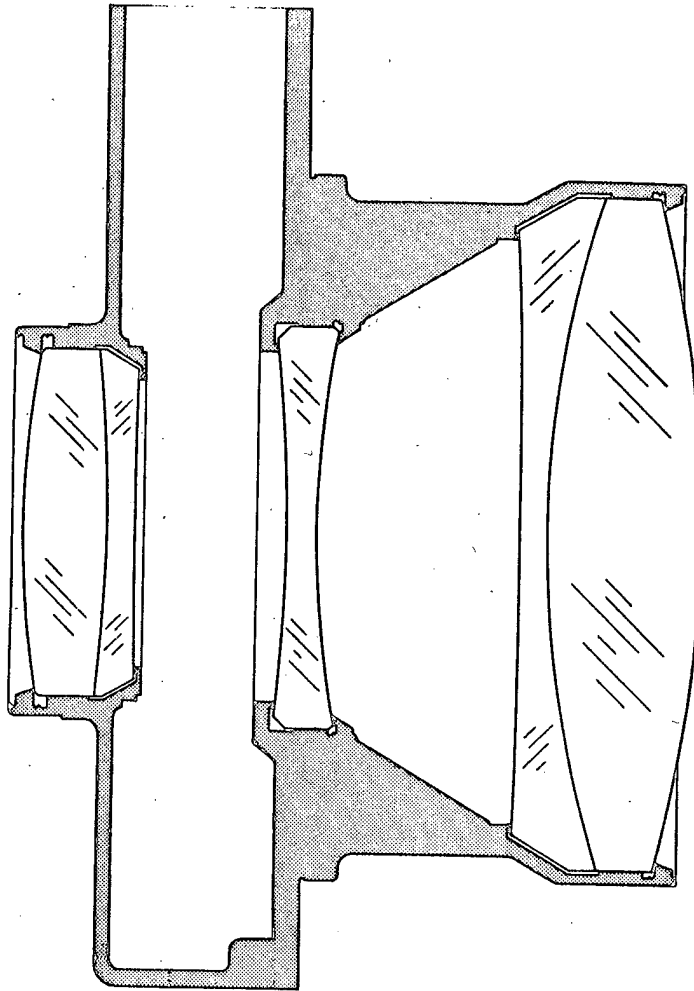

FIG. XI. 36" f/10 LENS

3. System for the C Configuration (Fig. No. XII)

The requirement for an optical system such as the "C" Configuration was based upon the need for a reconnaissance spotting system which would record specific targets and obtain maximum detailed information. It was envisioned that such a system would be used on missions which were planned on the basis of information gained by previous missions with other configurations. The original design and concepts of the "C" Configuration contained more sophisticated thinking and advancement in current technologies than any of the other configurations, and required a substantial advancement in the state of the art.

Original planning envisioned a camera with a long focal length optical system, IMC, magazine for 5,300 ft. of 3 mil film for 18 x 18 inch format, center of gravity mount for inertia stabilization, drive for oblique scan, a min-vib unit, an automatic exposure control, and a capability for several modes of operation.

During the first year of work on the "C" Configuration, the original configuration changed several times. Originally it was planned as a 200-inch re-imaging system with 18 x 18 inch format. It became evident that because of space limitations this focal length was impractical, and was changed to a 144-inch focal length system. Optical considerations dictated the next change, to a 120-inch re-imaging system. The final dimensions of 180-inch focal length, and 13 x 13 inch format were based on the primary need for maximum focal length. A "SKEW-Z" optical configuration was decided upon in order to make maximum use of the available space.

As originally planned, the configuration was designed with three modes of operation. In mode 1, the spotting mode, objects of interest could be selected by the operator of the periscope. This selection could be

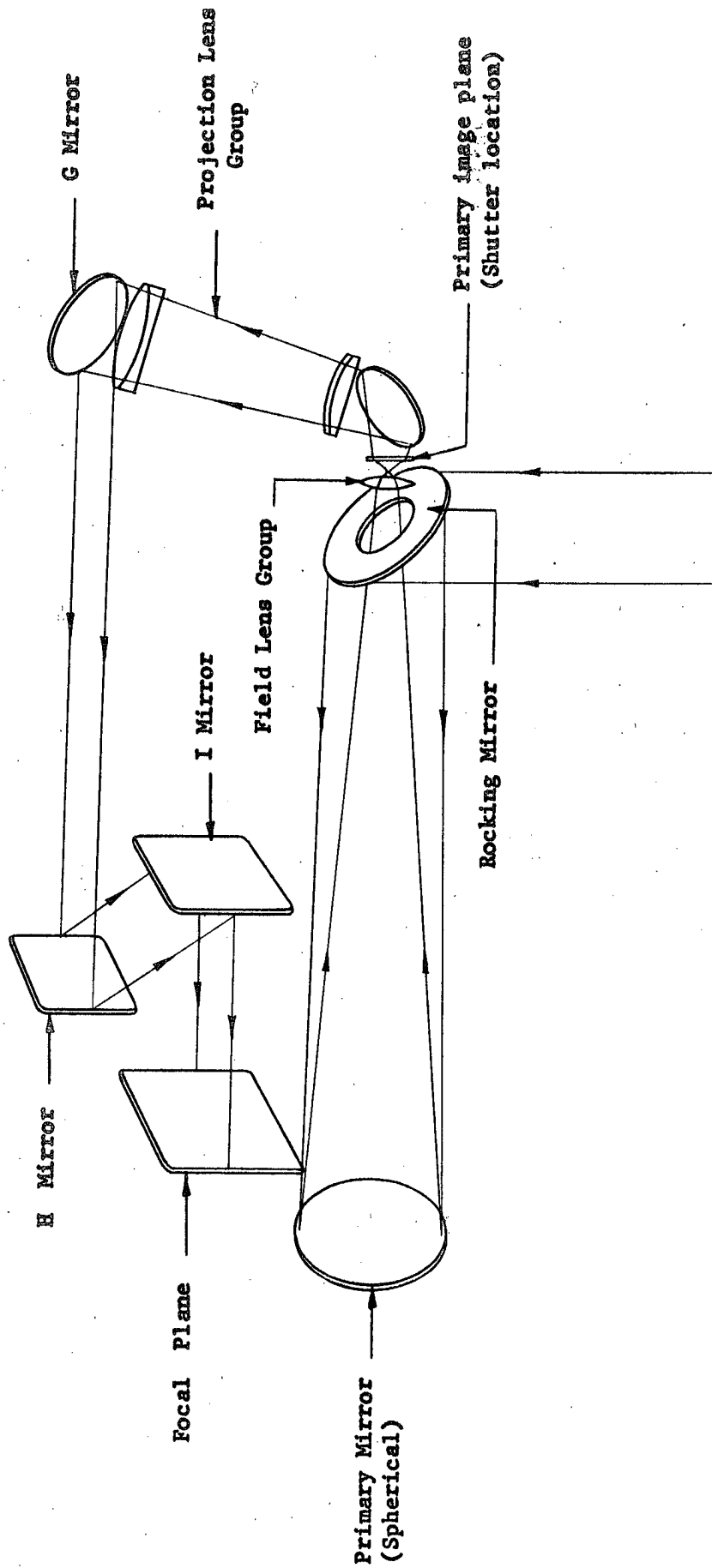

FIGURE XII

C SYSTEM

made ahead of the lateral plane of the aircraft. By pushing a button, the operator could store the desired object so that a burst of pictures would automatically be initiated when the selected object reached the lateral plane of the vehicle. A burst of six pictures with 60% overlap in the lateral direction resulted. Mode II, run away mode, permitted the camera to take photographs continuously from a fixed oblique angle position equal to the oblique angle of the periscope line of sight. In Mode III, alternating mode, the operation is similar to that of Mode II, except that the camera is cycled in oblique angle to provide 10% overlap in the lateral plane. Thus, the coverage along the line of sight track is the same as in Mode II but the area is wider by a factor of 1.9.

Under Perkin-Elmer engineering liaison, Hycon designed and constructed the hardware for six configurations. At the same time, optical work progressed at Perkin-Elmer facility from designs delivered by Dr. Baker. The first production camera was completed in October 1956.

Flight tests of this initial unit revealed several areas which required further work. Essentially, performance of this initial system indicated that results were far below design expectations. The programs which followed this initial investigation were all aimed at improving the resulting performance of the system. Certain design concepts were changed, optical quality was improved, although it was recognized that such factors as vibration were certain to cause image degradation.

Although many of the concepts used in the configuration were advancements in the state of the art, there were also occasions where ill-conceived designs were incorporated. During the various programs that occurred after the original unit was built, attempts were made to improve performance. New optics systems were made, new and modified components were installed, and

various changes were incorporated. Unfortunately, these attempts did not seem to meet the degree of improvement desired. Based upon the relative unsuccessful efforts to improve the system and based upon considerations of customer requirements, support for the "C" Configuration was terminated in the spring of 1958.

#### 4. Windows

With the exception of the Data Camera and the periscope which had their own protruding dome, all the other optical configurations needed windows in the equipment bay. Since an attempt was being made to obtain maximum resolution from each of the optical systems, it was imperative that the windows be of sufficiently high quality to avoid degrading the ultimate image. Thus, the design and construction of appropriate windows became more than a simple hardware problem.

Eight different sizes and shapes of windows were required. Because of the atmosphere and environment in which they were working, a study had to be undertaken to determine necessary window strength. Preliminary design included extensive tests to establish strength of glass on a statistical basis, and develop strength equations for designs. Production included 100% strength testing by hydrostatic pressure to insure that the windows were flawless and not subject to breakage. Optical requirements were held to strict pre-determined tolerances. The resulting window designs proved very satisfactory in use and pressure blowout or breakage never occurred.

D. Significant Auxiliary Equipment

1. Electronic Image Evaluator

In searching for a more accurate indication of lens quality a concept long familiar to communication engineers was suggested whereby a "transmission factor" is determined for each lens. This factor is the measure of the amount of information transmitted by the lens when imaging a lined pattern whose brightness varies harmonically across it. It is determined by dividing the amplitude of the sinusoidally varying brightness in the image by that in the object. A plot of this factor as a function of number of lines per millimeter in the pattern is highly informative. It provides information on the performance expected by the lens when imaging specific targets.

To be able to select and test the best possible reconnaissance lenses to be used with this program, a lens testing instrument based on these principles was built. In this instrument, a contrast transmission curve is obtained by analyzing electronically for the Fourier components of a periodically scanned slit image. This system presented advantages over the use of multiple slits in that data on almost all lined frequencies could be obtained using a single slit and a rotating mirror to scan its image across an exit slit.

Use of this instrument proved that there was unquestionably more useful information available from contrast transmission curves than from the standard resolution charts. The information presented was also more direct.

The instrument was used successfully in selecting and evaluating the performance of the 24 and 36 inch lenses, and in evaluating the effects of various modifications on these lenses.

2. Rotating Light Time Equipment (ROLIT)

Since the program was concerned with developing a series of



cameras which would give optimum performance, a system had to be developed which would adequately test the various functions of the different units. In addition to the standard type of ground tests usually employed on aerial reconnaissance cameras, it was proposed that certain in-flight testing be provided. In order to accomplish this an assembly of equipment known as the "rotating light time equipment" was built.

This equipment consisted of a rotating 12 sided mirror which sequentially reflected light to a line of 81 reflecting mirrors located on posts on the ground. These mirrors reflected the light skywards. In this manner, the equipment provided a string of blinking lights on the ground for use by airborne aerial cameras. The spacing sequence and rate of blinking was accurately known, thus providing a time and space standard. If a camera exposure was made of the blinking lights the developed negative yielded an accurate record of shutter speed, accuracy of I.M.C. and motion.

There were relatively few problems in building and installing this equipment. The major difficulty was in obtaining a light source of sufficient intensity. Even though the installation was accomplished, due to other technical difficulties with the equipment and the urgency of delivery, the equipment found very limited use.

It is felt that this type of test equipment is a sophisticated approach which will find great use in future programs.

### 3. Test Collimators (Fig. No's. XIII, XIV and XV)

In order to test the different optical configurations two types of collimating devices were designed and constructed. Both collimators were essentially the same except for focal length and aperture. One was a 100" f/25 system, while the other was a 300" f/27 system. The collimator design employed an off-axis optical system to contain the folded optical path. The

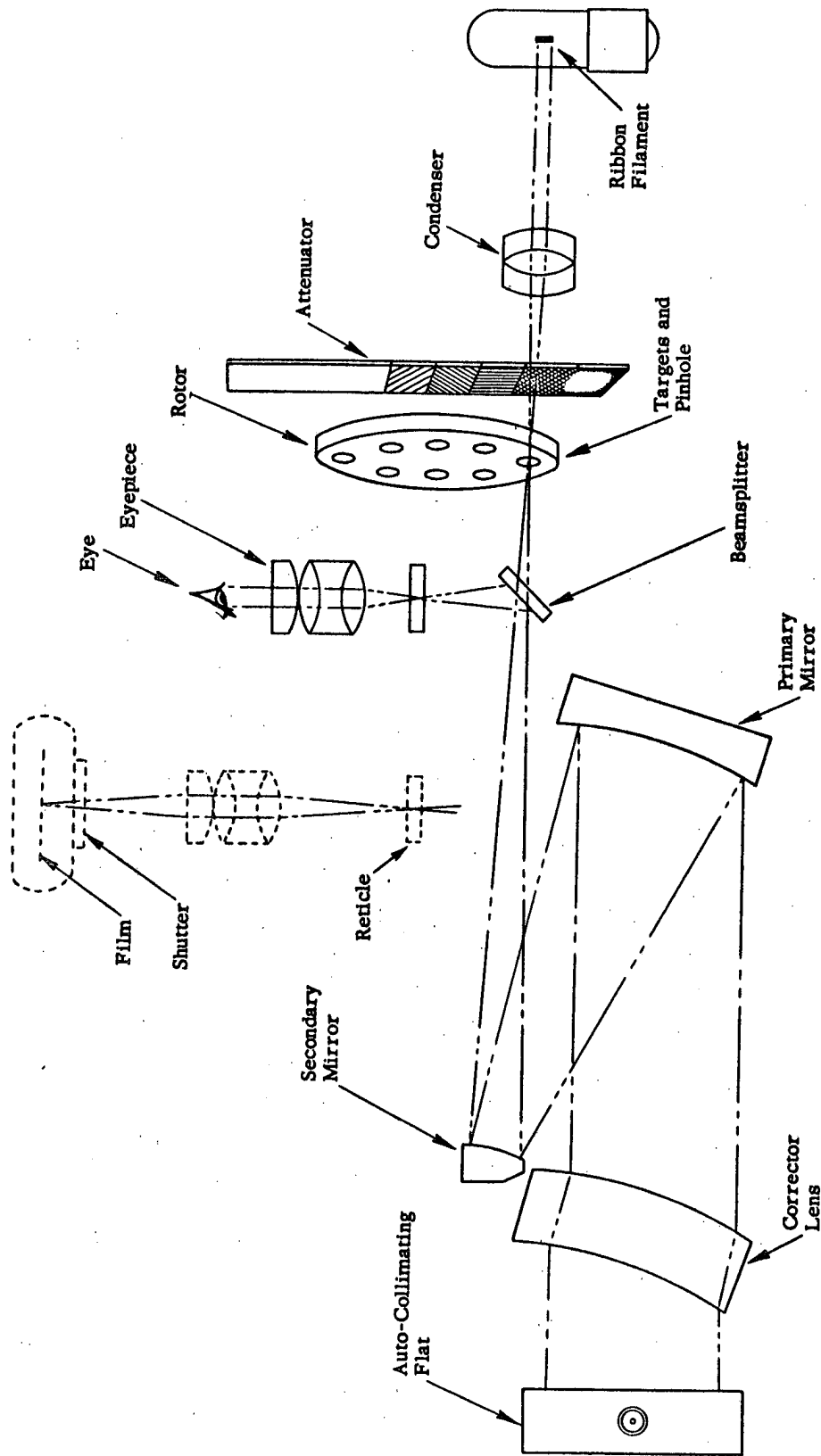

Figure XII. Optical Schematic Diagram.

collimator head contained a light source, various pin-holes and resolution targets, as well as a viewing eyepiece and attachment for a Land Camera. A scanning mirror was located at the objective end of the collimator to direct the collimated bundle either into the equipment being tested or back into the collimator head. Each collimator was mounted on a base which had adjustments necessary to facilitate its use.

Both collimators were used extensively in the field. The 300" collimator was limited mainly to use with the "C" Configuration. It was found that the 300" collimator, being of such long focal length, was very sensitive to such degrading influences as vibration and thermal gradients. Extreme precautions had to be taken when it was used so that its effects were not misconstrued to be that of the optical system under test.

Less sensitive to vibration and thermal effects, the 100" system proved to be very versatile and useful in testing the A and B configurations.

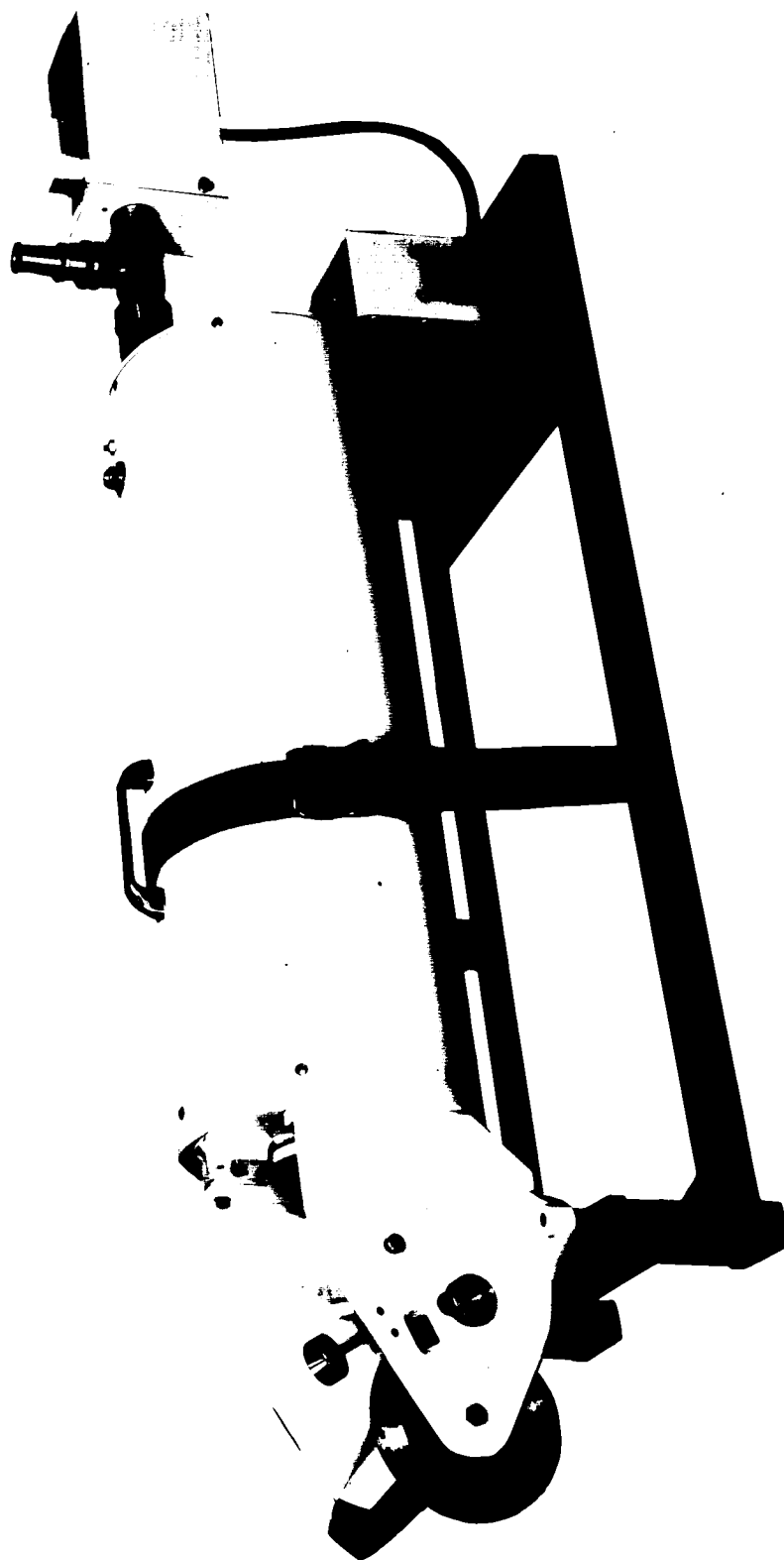

Figure XIV 100" COLLIMATOR

Report No. 5490

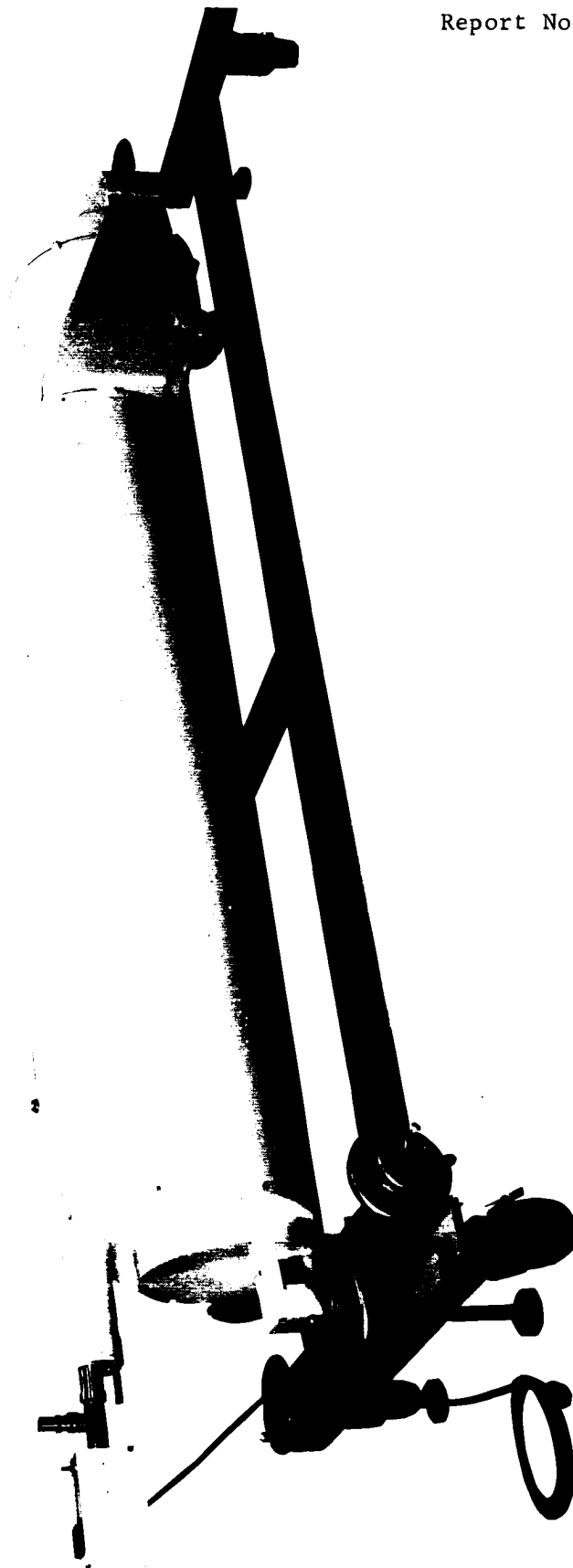

Figure XV. 300" COLLIMATOR

VI. CONCLUSIONS

The program was quite successful, and this can be attributed to three considerations:

1. The contracting organization engendered maximum application of technical talents by permitting the suppliers great freedom in technical decisions and choice of subcontractors, and encouraging close liaison among the suppliers. In addition, the contracting organization was at all times receptive to imaginative approaches to technical problems, fully appreciative that advancements in the state of the art were necessary to preserve the intention of the program.
2. The concept of a completely compatible photographic reconnaissance system, designed from its inception for a particular set of conditions, as opposed to the more usual assemblage of universal components, has markedly increased the ability to obtain maximum information for a specific type of mission. This is best exemplified by the fact that optics design was predicated on detection of medium and low contrast objects; not the high contrasts usually employed as design bases, which are not found under actual flight conditions. Optics designs were tempered by considerations of parameters of films which would be available. Films were tailored to obtain maximum compatibility with the image forming system. Mechanical structures were designed with stabilization requirements, vibration frequencies and levels, and with performance goals in mind.
3. The services of manufacturers' field engineers were exclusively employed for maintenance and operation. These field services were in close liaison with the continuing product improvement programs maintained by the manufacturers. The field activities included periodic visits by high level technical support groups.

The results have been impressive. Embodied in the equipment of this program are several technical advancements, numerous functional improvements as well as examples of the application of unique techniques and philosophies which contributed to advancements to the state of the art of aerial reconnaissance. Performance levels of modified standard equipment in the A<sub>1</sub> Configuration have nearly doubled. The A<sub>2</sub>, employing a modified standard camera, but special optics, has increased performance capability even more. The B Configuration, employing the new philosophy of object space scanning, obtained consistent resolution levels far in excess to any obtained with standard equipment of equivalent focal length, and thus introduced a new reconnaissance technique. The Panoramic Camera virtually out-performed and obsoleted the tri-metrigon system for aerial reconnaissance where space, weight and reliability were considerations.

Although the termination of the C Configuration did not provide the ultimate "spotting operation" desired, the system nevertheless developed four advanced design features: (1.) a reimaging projection system, (2.) a center of gravity support, (3.) object space scanning, and (4.) lightweight reflecting optics. During tests this configuration produced results which yielded more information than any other known photographic reconnaissance camera.

The capability of target storage, as embodied in Mode I operation of the C Configuration, successfully demonstrated a new and impressive capability which could be incorporated in other reconnaissance systems. The Memory Unit itself represents an advance in the state of the art as a mechanical mechanism capable of reliably performing its functions, yet being at the same time lightweight and compact.

In order to be able to comprehensively evaluate design and performance characteristics of the optics, new evaluation techniques had to be developed which would yield more information than the standard resolution tests.

The image evaluator which resulted has led to concepts which are now finding wide interest in the industry and which promise to become standard tools of the trade.

Acute weight considerations led to the use of ribbed construction of high quality optical mirrors in the B and C Configurations. The lightweight construction of the mirrors in these systems showed that such a philosophy was practical.

Additionally, more sophisticated testing and handling techniques were developed which permitted a more comprehensive knowledge of equipment capabilities so necessary to maintaining the equipment at maximum operating conditions.

In conclusion, the prime factor in the success of this program was the integration of vehicle and equipment performances. All vehicle functions were designed to accommodate the specific mission, and all reconnaissance equipment considered both mission and vehicle characteristics. This is an ideal, but unfortunately rare, consideration and this organization is most pleased to have participated in this enterprise.



APPENDIX

LIST OF PERTINENT PUBLICATIONS

<u>Publication Number</u>	<u>Description</u>
151-1374	Instruction Manual for Model 151 Tracking Camera and Test Equipment
522-0026	Instruction Manual for MK I-A Tracking Camera and Test Equipment
152-1571	Instruction Manual for Model 152 Hand Control and Periscope, Model 153 Memory Computer and Junction Box, and Test Equipment
162-1235	Instruction Manual for Model 162 100-inch f/25 Auto-Collimator
162-1236	Instruction Manual for Model 162 300-inch f/25 Auto-Collimator
- - - -	Final Engineering Report - Aerial Surveying Equipment Program, by Hycon Manufacturing Company
- - - -	Summary Test Report 73-C Configuration - Approximately April 1958, by Hycon Manufacturing Company