



**MCI CONSTRUCTORS, INC.**

7649 Dynatech Court  
Springfield, Virginia 22153

Address replies to:  
P O. Box 2786  
Springfield, Virginia 22152

Telephone (703) 569-8010  
TWX 710-831-0333 MCI ALE

CLIENT: General Services Administration

PROJECT: CIA Headquarters Expansion  
Bid Package 3 - Powerhouse Modifications

SUBMITTAL DATE: October 22, 1985

SUBMITTAL NUMBER: 131

SPEC. SECTION: 15616 VENDOR: Potomac Water & Waste  
Systems, Inc.

EQUIPMENT DESCRIPTION: O&M Manual: Hot Zeolite Return Condensate Softener System

STATUS: Approved for submittal as clarified

C.Q.C. REPRESENTATIVE:           *B J Fleming*            
Brian J. Fleming

**VARIATIONS AND CLARIFICATIONS**

1. This operation and maintenance manual submittal applies to the hot zeolite return condensate softener system as described in Specification Section 15616, Paragraph 17.

*AJP 11/7/85*

# OPERATING INSTRUCTIONS

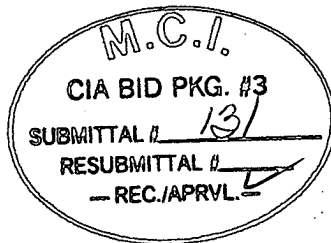

POTOMAC WATER  
& WASTE SYSTEMS, INC.  
202 WHEATON PLAZA BUILDING NORTH  
WHEATON, MARYLAND 20902

# OPERATING INSTRUCTIONS

*for* WATER CONDITIONING EQUIPMENT

Date October, 1985

Job No. VW-943

Contract No. GS-11B-19067

Prepared for C. I. A. (POWER HOUSE)

Langley, VA

TWO 84" DIA. CONDENSATE POLISHERS

AJD 11/7/85 1

Potomac Water &  
Waste Systems, Inc.  
202 Wheaton Plaza, Bldg. N  
Wheaton, MD 20902-1965

OPERATING INSTRUCTIONS

TABLE OF CONTENTS

GENERAL DESCRIPTION

DATA

AQUA-MATIC CONTROLLER Model 1606-2C  
STAGERS Model 481-11  
Print 48A-1184 (Dwg. E-48-123)  
Bulletin 48/51-682

AQUA-MATIC DIAPHRAGM VALVES  
Bulletin 8000-1182

BADGER TURBO METER, 2"  
Meter Bulletin MT-4702  
Meter O&M Manual IOM-003-07  
AR Register Head Bulletin IAR-3011  
AR Register Head O&M Manual IOM-024-06

FISCHER & PORTER RATE-OF-FLOW INDICATOR  
Series 71K1020  
Instruction Bulletin 71K1020-C, Rev. 2  
Parts List 71K1020-C

Reference Drawings:

Layout -- 943-1P, Rev. A  
Internal Details -- 943-2P

OPERATING INSTRUCTIONS

These units, water softeners operating on the sodium cycle, are used to remove calcium and magnesium hardness from the returning condensate. Such hardness enters into the return system generally from unexpected leaks involving a city water source. The degree of hardness in the condensate is a matter of how many leaks are producing these undesirable contaminants in the boiler feeder cycle. Normally a well maintenance system should only show hardness of a few parts per million (ppm), certainly less than 10 ppm.

The ability of each softener to remove hardness is a function of how much is in the condensate to begin with and how many cubic feet of water softening resin is available in each unit. Based on data available in the job specifications, the expected operating data is as follows:

Each 84" dia. unitService Run:

Normal flow rate . . . . .	450 gpm
Length between regenerations (assuming 10 ppm hardness in raw water) . . . . .	2,000,000 gal.
Expected pressure drop . . . . .	15 psi max.
Expected operating temperature . . . . .	180° F max.

It is expected that only one unit need be on line at the known flow rate with the other in stand-by. Since it may be several days before the on-line unit exhausts, the build up in pressure drop should be monitored. Even though the hardness is still being removed, it is suggested that a  $\Delta p$  of 12-15 psi be the indication that it is time to regenerate. The off-line unit should be secured manually until such time as it is needed on line. For flow rates up to 450 gpm, having only one unit on line will provide a better suspended particle removal (iron and other products of corrosion in the condensate.) At this rate the resin bed is sufficiently compressed to provide its best filtering action.

OPERATING INSTRUCTIONS

Regeneration (Using ambient temperature city water)

Step 1 Backwash: 200 gpm for 12-15 minutes

Step 2 Brine step:

Salt required . . . . 1,170 lbs. or 470 gal  
of saturated brine solution

Dilution water . . . . 470 gallons

Diluted brine . . . . 47 gpm for 20 min.

Step 3 Slow rinse . . . . . 23 gpm for 30 min.

Step 4 Fast rinse . . . . . 230 gpm for 12 min.

Operating Notes

1. Before each regeneration is initiated, the operator must be sure that the brine measuring tank is full. The required draw-down to produce the 470 gal. of brine is 50". The actual brine draw is on an adjustable timed basis with 20 minutes being the expected setting.
2. As a unit comes off line (assuming only one in service at a time), it should be secured via the effluent gate valve being closed. A card or sign should be hung on the valve to show its closed position. The regeneration should not be done until just prior to its expected return to service.

**PILOT CONTROL ASSEMBLY (48-AE)**

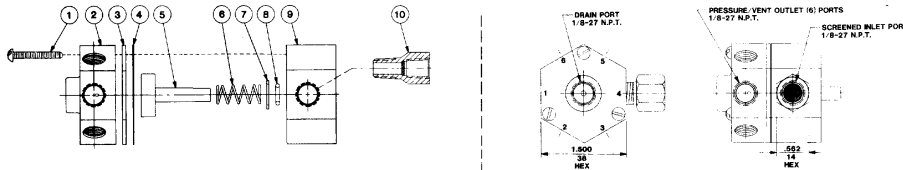

ITEM	DESCRIPTION	PART NO.	QTY.
1	PILOT CONTROL ASSEMBLY (48-AE)		
1	RD. HD. MACHINE SCREW (8-32 X 7/8)	SCS-0079	3
2	BACKPLATE	48-A	1
3	BACKPLATE GASKET	48-F	1
4	GASKET	SEE CHART	1
5	STEMPLATE		
6	SPRING	48-G	1
7	RETAINER	41-F	1
8	O-RING	ORB-010	1
9	ISORNET	48-E	1
10	STAINER ASSEMBLY	48-D	1
<b>SERIES 48 MOTORIZED STAGER - STANDARD</b>			
11	PILOT CONTROL ASSEMBLY	48-AE	1
12	CABLE CLAMP	319-U	1
13	RD. HD. MACHINE SCREW (8-32 X 1/4)	SCS-0081	1
14	SWITCH	318-F	1
15	RD. HD. MACHINE SCREW (2-56 X 1/2)	SCS-0056	2
16	FLAT HD. MACHINE SCREW (8-32 X 3/8)	SCS-0105	6
17	MOUNTING PLATE	48-BC	1
18	MOUNTING PLATE GASKET	48-BE	1
19	STAND OFF	48-BA	2
20	INSULATOR	51-R	1
21	SWITCH ACTUATOR	510-AU	1
22	CAM	SEE CHART	1
23	MOTOR	51-SE 115 VOLT 60 HZ. 230 VOLT 60 HZ. 24 VOLT 60 HZ. 51-MC	1
24	LOCKWASHER (NO. 4)	WAL-0003	2
25	RD. HD. MACHINE SCREW (8-32 X 3/8)	SCS-0070	2
<b>SERIES 48 MOTORIZED STAGER - (1) ALUMINUM SWITCH</b>			
14	SWITCH	318-F	2
15	RD. HD. MACHINE SCREW (2-56 X 3/4)	SCS-0059	2
18	STAND OFF	48-BA	2
19	INSULATOR	51-R	2
20	SWITCH ACTUATOR	510-AU	2
21	CAM	SEE CHART	2
<b>SERIES 48 MOTORIZED STAGER - (2) ALUMINUM SWITCHES</b>			
14	SWITCH	318-F	3
15	RD. HD. MACHINE SCREW (2-56 X 1/2)	SCS-0060	2
18	STAND OFF	48-BA	2
19	INSULATOR	51-R	3
20	SWITCH ACTUATOR	510-AU	3
21	CAM	SEE CHART	3
<b>SERIES 480 MANUAL STAGER</b>			
11	PILOT CONTROL ASSEMBLY	48-AE	1
26	RD. HD. MACHINE SCREW (2-56 X 1/8)	SCS-0063	2
20	ACTUATOR	510-AU	2
27	MEX. SOC. SET SCREW (5-40 X 1/4)	SCS-0110	1
28	DOO	48-D	1
29	STAND OFF	48-C	4
30	SELECTOR PLATE	48-A	1
31	FLAT HD. MACHINE SCREW (8-32 X 3/4)	SCS-0106	4
32	SELECTOR KNOB	48-D	1
<b>REPAIR PARTS KITS - FOR STANDARD ONLY</b>			
48-1A	INTERNAL PARTS FROM 48-AE		
48-MA	MOTOR - CAM - DIAL PARTS		
48-SA	SWITCH PARTS		
48-RA	INCLUDES KITS 48-1A, 48-MA, & 48-SA		

**SERIES 48 MOTORIZED STAGER - STANDARD**

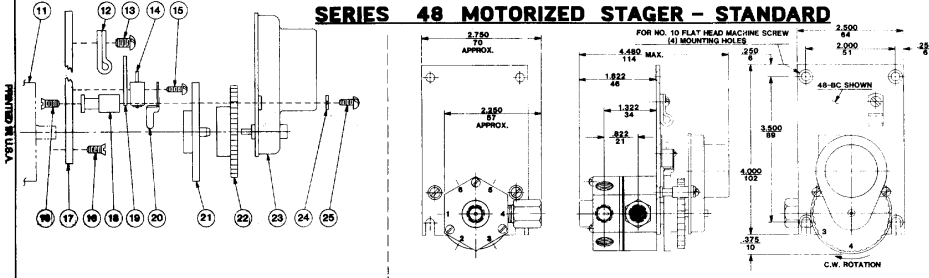

**SERIES 480 MANUAL STAGER**

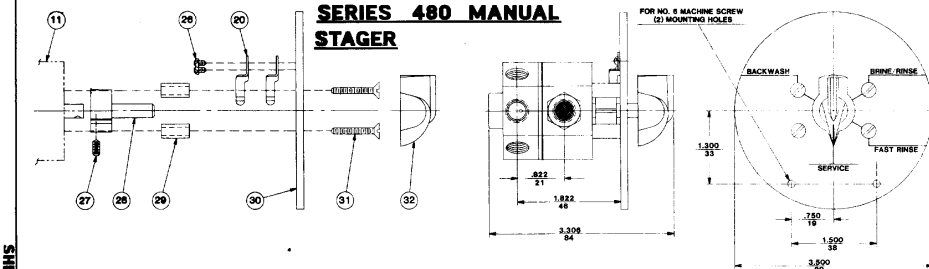

CAM STYLES (PN SIDE SHOWN)

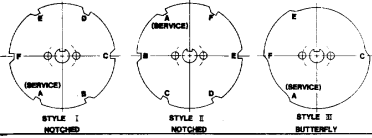

STAGER SERIES	FUNCTION	TOTAL POS.	BACKPLATE PORTS VENTED AT CAM POSITION						STEMPLATE PART NO.	CAM PART NO.	CAM STYLE	DIAL PART NO.
			A	B	C	D	E	F				
48-0	SOFTENER	4	1-2	3-4	5-6	7-8	9-10	48-CM	48-OM	I	48-EM	
48-1	FILTER	3	1-2	3-4	5-6	7-8	9-10	48-CM	48-WM	I	48-EM	
48-3	SOFTENER	4	1-2	3-4	5-6	7-8	9-10	48-CM	48-OM	I	48-EM	
48-4	FILTER	2	1-2	3-4	5-6	7-8	9-10	48-CM	48-OM	I	48-EM	
48-11	SOFTENER	4	1-2	2-3	4-5	5-6	7-8	48-CM	48-OM	I	48-EM	
48-12	SOFTENER	4	1-2	3-4	4-5	5-6	7-8	48-CM	48-GPM	I	48-EM	
48-8-3	FILTER	8	8	1	2	3	4	48-CE	48-OM-4	II	48-EM-4	
48-9-4	FILTER	6	6	1	2	3	4	48-CE	48-OM-5	II	48-EM-5	
48-9-5	FILTER	6	6	1	2	3	4	48-CE	48-OM-5	II	48-EM-5	
480	SOFTENER	4	1-2	3-4	5-6	7-8	9-10	48-CM				

FOR CONTINUATION, SEE DWG. NO. E-48-123

**AquaMatic**  
 ROCKFORD, ILL. U.S.A.  
**SERIES 48 MOTORIZED STAGER AND**  
**SERIES 480 MANUAL STAGER**

INCH  
 MILLIMETER

MM/VP 11/1/84 E-48-122

OVER SHEET NO. 48-1184

E-48-122

SERIES 48 MOTORIZED STAGER - ROTARY SWITCH (OPTION X)

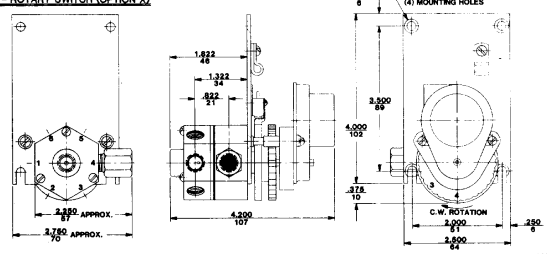
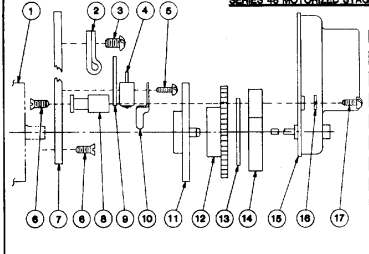

ITEM NO.	DESCRIPTION	QUANTITY
1	PILOT CONTROL ASSEMBLY (SEE E-48-122)	48-AE 1
2	CABLE CLAMP	51-RU 1
3	NO. 10 MACHINE SCREW (8-32 X 1/4)	SCB-0081 1
4	SWITCH	51-R 1
5	NO. 10 MACHINE SCREW (8-32 X 1/2)	SCB-0082 2
6	FLAT HD. MACHINE SCREW (8-32 X 3/8)	SCB-0105 6
7	MOUNTING PLATE FOR NEMA 1	48-BC 1
8	STAND OFF	48-CA 2
9	INSULATOR	51-R 1
10	SWITCH ACTUATOR	510-AU 1
11	CAM	SEE CHART 1
12	DIAL ON E-48-122	1
13	ROTARY SWITCH (MAXIMUM CURRENT 25 AMP)	48-XE 1
14	SWITCH ENCLOSURE	48-XC 1
15	MOTOR 115 VOLT 60 HZ 51-REX 1	
16	LOCKWASHER (NO. 8) 230 VOLT 50 HZ 318-RE 1	
17	NO. 10 MACHINE SCREW (8-32 X 3/8) 318-REX 2	
18	ENCLOSURE NEMA 1	48-H 1
19	PL. NO. MACH. SCR. (10-32 X 1/4) FOR NEMA 1	SCB-0108 4
20	STAGER SEE CHART	1
21	MOUNTING PLATE FOR	48-SB 1
22	MOUNTING PLATE GASKET NEMA 4	48-HE 1
23	HEX HD. MACH. SCR. (10-32 X 1/4) ON	510-RU 4
24	LOCKWASHER (NO. 10) NEMA 12	WAS-0008 4
25	HEX NUT (10-32) NEMA 12	WAS-0008 4
26	ENCLOSURE NEMA 4	48-HE 1
	NEMA 12	48-HA 1

SERIES 48-1 MOTORIZED STAGER - NEMA 1

SERIES 48-1 MOTORIZED STAGER - NEMA 4 OR 12

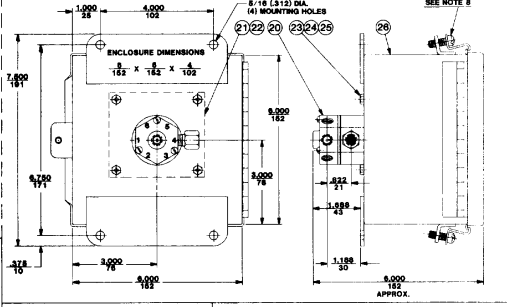
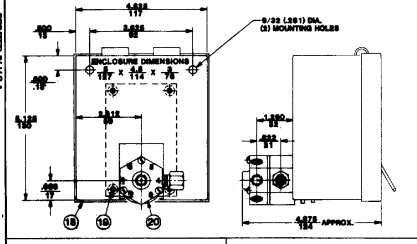

NOTE: UNLESS OTHERWISE SPECIFIED:  
 1. DIMENSIONS ARE NOMINAL.  
 2. MODEL 48-3 STAGER SUPPLIED WITH BUTTERFLY CAM (4 POSITIONS ONLY); FOR USE WITH SHIFT OUTPUT TYPE TIMER. (SEE CHART ON E-48-122).  
 3. ALL OTHER MOTORIZED STAGERS SUPPLIED WITH NOTCHED CAM FOR USE WITH PULSE OUTPUT TYPE TIMERS. (SEE CHART ON E-48-122).  
 4. STAGERS WITH INVERTED PROGRAM ARE AVAILABLE.  
 5. CONTROL PRESSURE TO THE STAGER CAME EITHER HYDRAULIC OR PNEUMATIC AND MUST BE WITHIN 10% OF THE SYSTEM PRESSURE; NOT TO EXCEED 100 P.S.I. (8.8 ATM).  
 6. FOR PROGRAMS OTHER THAN SHOWN, CONSULT FACTORY.  
 7. ALL STAGERS CAN BE MANUALLY ADVANCED BY ROTATING THE DIAL IN DIRECTION SHOWN.  
 8. NEMA 12 ENCLOSURE HAS (1) CLAMP AND NEMA 4 ENCLOSURE HAS (3) CLAMPS.

ROTARY SWITCH (OPTION X) WIRING DIAGRAM

AUXILIARY SWITCH NOTES

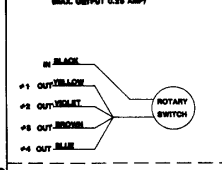

1. WHEN ORDERING MOTORIZED STAGERS WITH AUXILIARY SWITCHES, SPECIFY IN WHICH STAGER POSITION(S) SIGNAL IS REQUIRED.  
 2. ROTARY SWITCH (OPTION X) CANNOT BE COMBINED WITH AUXILIARY SWITCH OPTION.

(2) AUXILIARY SWITCHES WIRING DIAGRAM

STANDARD PROGRAM FOR SERIES 48-0, 48-3, AND 48-0

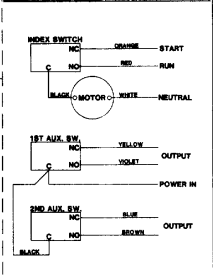

STAGER POSITION	FUNCTION	PORTS WIRING
1	BACKWASH	3 & 4
2	URINE AND SLOW RINSE	5 & 6
3	FAST RINSE	6 & 1
4	SERVICE	1 & 2

FOR:  
 - 1 STAGER (3 POSITION FILTER) OMIT POSITION 2  
 - 4 STAGER (2 POSITION FILTER) OMIT POSITIONS 2 & 3

STANDARD WIRING DIAGRAM

(1) AUXILIARY SWITCH WIRING DIAGRAM

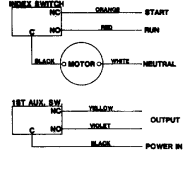
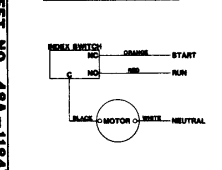

INCH MILLIMETER  
 FOR CONTINUATION, SEE DWG. NO. E-48-122

**Aqua-Matic**  
 ROCKFORD, ILLINOIS  
 SERIES 48 (OPTION X) AND SERIES 48-1 MOTORIZED STAGER

MM/VP	DIV	DATE
	11/5/84	E-48-123

PRINTED IN U.S.A.

SHEET NO. 48A-1184

E-48-123



# DIAPHRAGM VALVES FOR FLUID TREATMENT & HANDLING SYSTEMS

## Diaphragm Valves

- **Lowest pressure loss.**  
Y pattern permits higher flows at lower pressure loss than any comparable valve.
- **Positive control.**  
Separate flow and control chambers permit positive closing without springs; and only nominal cost for spring assist opening for low pressure and self draining considerations.
- **Cost effective.**  
Both initially and in lifetime maintenance.
- **Extended diaphragm life.**  
Separate chamber protects diaphragm from flow stream; allows replacement without disrupting service. Pre-formed, stress relieved diaphragm minimizes fatigue, maximizes valve responsiveness and diaphragm lifetime.
- **Durable.**  
Cast iron, brass, bronze, stainless steel, and engineering thermoplastic components. Average maintenance free life of 5 years.
- **Design/Application engineering service.**
- **Optional seal and diaphragm materials for special applications.**
- **Handles liquids or gases.**
- **Adaptable to a variety of control devices.**
- **Optional adjustable flow rate control.**
- **Optional spring assist.**
- **Optional position indication.**

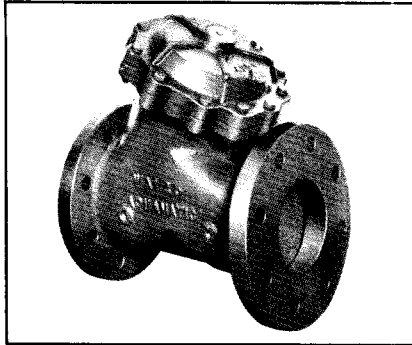

## Metal Body Valves

### Series 421 through 429

Body and cap of cast iron or brass. Pre-formed, stress relieved diaphragm of Buna N on Nylon for long life. Stainless steel and brass internal parts.

Pipe sizes of 3/4" through 3" threaded (N.P.T. or B.S.P.); 3" through 6" flange drilled in accordance with ASA 16.1, Class 125, or B.S. 4504 (ISO/R 2084).

#### Operating specifications:

Pressure—Standard 125 psi (8.5 Atm.) rating.  
(300 psi available).

Temperature—  
Maximum 150°F (65°C);  
optional 250°F (120°C).

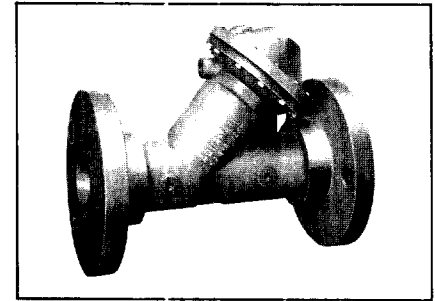

## Plastic Body Valves

### Series 520 through 526

Designed for de-ionized water, corrosive liquids or gases, caustics and acids (Not applicable for aromatic hydrocarbons). Body and cap molded of 30% glass reinforced engineering thermoplastic resin. Diaphragm is Buna N on Nylon and static seals are ethylene propylene. Viton and Butyl seal options available. Line fluid never contacts a corrodable surface.

Pipe sizes range from 3/8" to 3" with optional fittings—threaded, solvent bond, or flanges.

#### Operating specifications:

Pressure—Maximum 125 psi (8.5 Atm.).

Temperature—32°F to 140°F (0° to 60°C).

## PRINCIPLES OF OPERATION

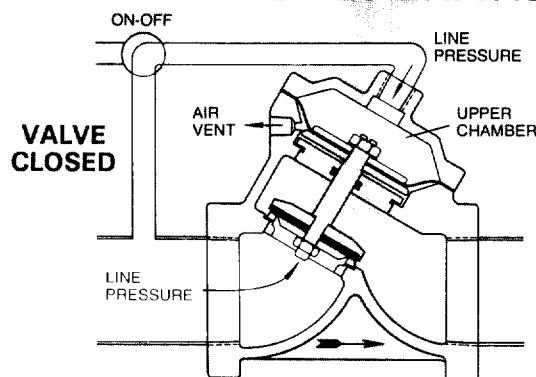

**Drip-Tight Closing:** Closure is obtained by directing line pressure or equivalent independent pressure into the upper chamber. This pressure on the large diaphragm area causes the valve disc to seal against the seat.

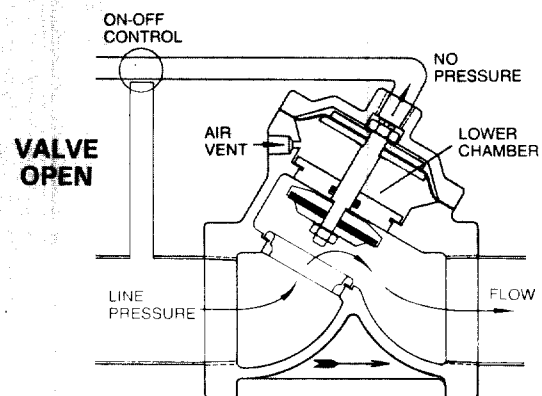

**Full Open Operation:** When closing pressure, in upper chamber, is relieved by venting the pilot line, the valve opens, positively, by line pressure on the disc.

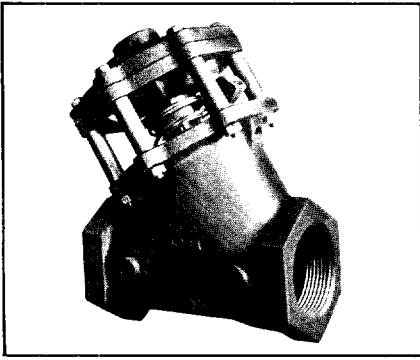

**Isolated Bonnet Valves  
Series 4421 through 4429**

Designed for high temperature applications that might cause accelerated deterioration of diaphragm in standard valve. Isolated bonnet prevents heat from reaching diaphragm.

Any leakage that may occur is quickly obvious around dynamic seal. Line fluid cannot contaminate pneumatic/hydraulic control because diaphragm is not accessible to fluid carrying chamber of valve.

Optional indicator on valve stem permits positive, direct reading of valve position. Also, includes all the options and features of standard "Y" pattern valves; and available in same sizes and construction as standard "Y" pattern valves.

**Operating specifications:**

Pressure—Standard 125 psi (8.5 Atm.) (300 psi available).

Temperature—Maximum 300°F (148°C). (Consult factory for higher temperature applications).

Note: Plastic Series 5500 also available. Contact factory.

Note:  
Chart applies to all metal diaphragm valves illustrated in this catalog:  
Series 421-429;  
Series 4421-4429;  
Series 3500; and  
Series 3000.  
 $C_v$  = Flowrate (G.P.M.) of water at 60°F (15.5°C) at 1 P.S.I. pressure drop.  
Liters per minute = G.P.M. x 3.78.

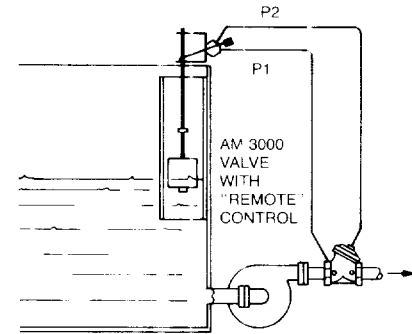
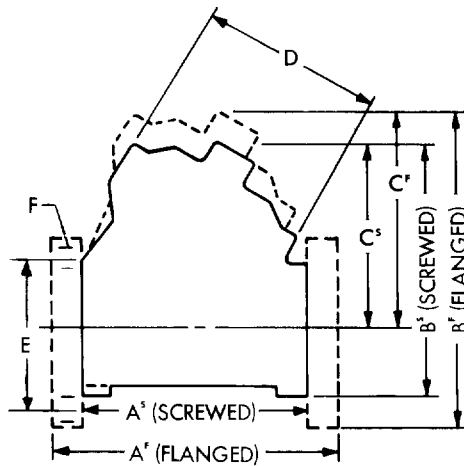
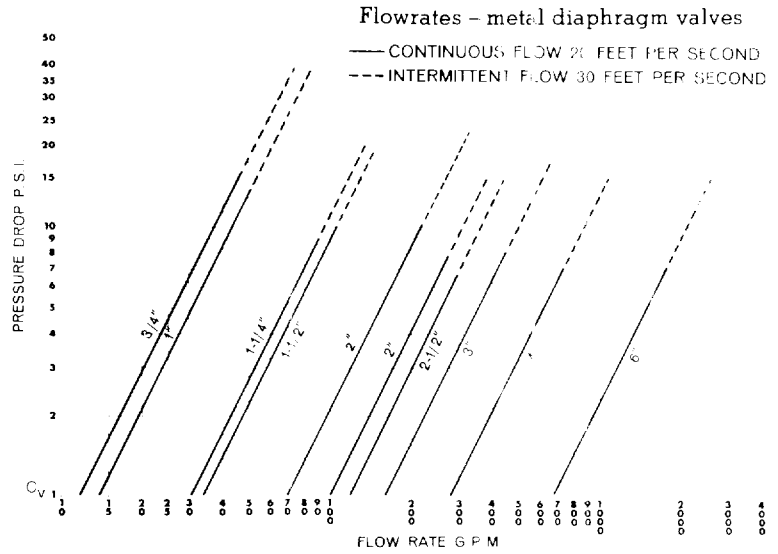

**Model 348LC Level Control**

For mounting float actuated pilot remote from diaphragm valve. Control fluid is delivered to and from the diaphragm chambers through ports P1 and P2 of the pilot. Up and down positions of the float determine which port is pressurized, and which port is vented. May be used with either metal or plastic valves.

DIMENSIONS																
Size	Ends	Series		ISOLATED BONNET VALVES										D	E	F
				A <sup>S</sup>	A <sup>F</sup>	B <sup>S</sup>	B <sup>F</sup>	C <sup>S</sup>	C <sup>F</sup>	B <sup>S</sup>	B <sup>F</sup>	C <sup>S</sup>	C <sup>F</sup>			
3/4-1	SCRD	421	In.	3.68		4.25		3.75		5.62		4.62		2.75		
		4421	mm.	94		108		82		140		115		70		
1 1/4-1 1/2	SCRD	424	In.	4.75		5.37		4		7.62		6.25		3.50		
		4424	mm.	120		136		101		190		160		89		
2	SCRD	425	In.	6.62		7.25		5.37		9.37		7.50		4.87		
		4425	mm.	168		184		136		240		190		123		
2-2 1/2	SCRD	426	In.	7.37		8		5.75		10.5		8.25		6.25		
		4426	mm.	187		203		146		265		210		155		
3-S	SCRD	427-S	In.	9		9.75		6.75		12.25		9.25		7.25		
		4427-S	mm.	228		247		171		310		235		184		
3-F	FLGD	427-F	In.		10.62		10.75		7		13.00		10.75	7.25	6	0.75
		4427-F	mm.		270		273		178		330		275	184	160	18
4-F	FLGD	428-F	In.		11.75		14.75		10		18.00		13.75	8.75	7.5	0.75
		4428-F	mm.		298		375		254		455		350	222	180	18
6-F	FLGD	429-F	In.		17		19		13.50		25		18.50	15.75	9.5	0.87
		4429-F	mm.		431		482		343		635		470	402	240	20

B.S.P. threads optional on series 421 thru 427, and 4421 through 4427.  
European flanges optional on series 427 thru 429, and 4427 through 4429.

**Series 3500 SOLENOID-CONTROLLED**

Series AM-3500 (Energize to open)

Series AM-3510 (Energize to close)

Equipped with solenoid for control by timer, flow meter, pressure or temperature sensor, liquid level or manual switch.

Specify "independent pressure" if a separate source of control fluid is used.

Ideal for automated, continuous process systems.

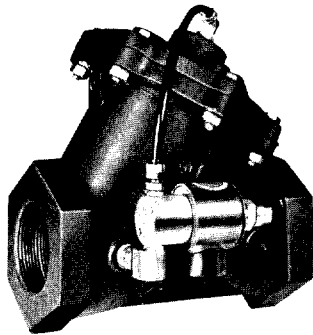
**Series 3000 FLOAT-CONTROLLED**

Float provides accurate control of liquid levels in constant cycling reservoir without surge or shock. Positive open or closed positions—not affected by minor changes in liquid levels. Remote float mounting available.

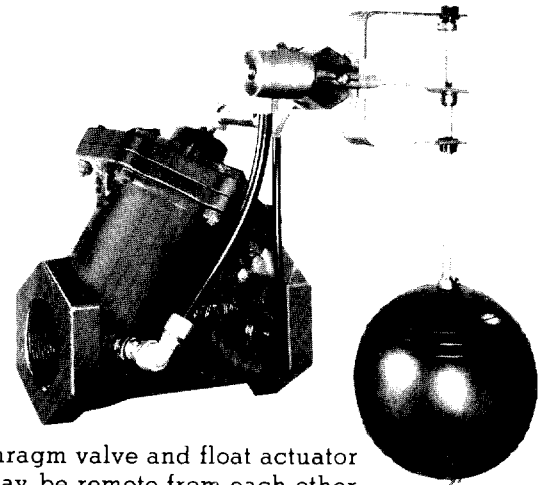

Note: Diaphragm valve and float actuator assembly may be remote from each other. See illustration of Model 348LC Level Control on preceding page.

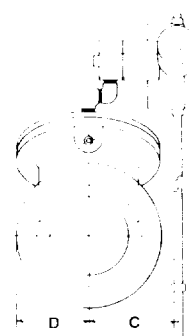
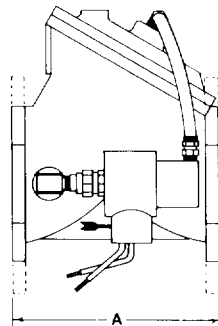
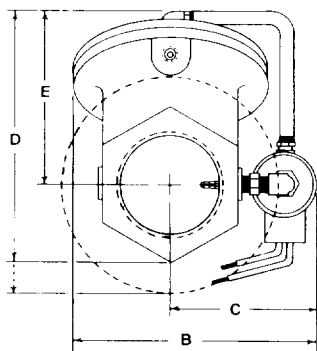

2 1/4" 57 MM. ± TRAVEL

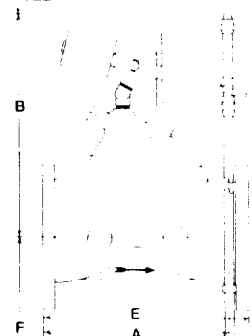

5" DIA. 127 MM.

SERIES 3500									SERIES 3000						
	SIZE	SERIES	DIM.	A	B	C	D	E	SIZE	A	B	C	D	E	F*
SCREWED	3/4"-1"	421	In. mm.	3.75 95	4.37 111	3.25 82.5	5.12 130	4.12 105	3/4"-1"	7.20 182	6.50 165	1.70 43.1	3.00 76.1	3.68 93	29 735
	1 1/4"-1 1/2"	424	In. mm.	4.75 121	5.00 127	3.50 89	6.00 152	5.00 127	1 1/4"-1 1/2"	8.29 210	7.81 198	4.20 107	1.75 44.4	4.75 120	28 711
	2"	425	In. mm.	6.62 168	6.75 171	4.12 105	8.25 209	6.37 162	2"	9.29 236	8.37 212	5.20 145	2.69 68.2	6.62 168	27 686
	2"-2 1/2"	426	In. mm.	7.37 187	7.25 184	4.25 108	9.00 229	6.75 171	2"-2 1/2"	9.87 250	9.56 243	5.20 145	3.06 77.6	7.37 187	26 660
	3" S	427	In. mm.	9.12 231	8.50 216	4.50 114	10.75 273	7.75 197	3" S	10.8 274	10.56 268	6.20 157	3.62 91.8	9 228	25 635
FLANGED	3" F	427-F	In. mm.	10.62 270	8.50 216	4.50 114	11.75 298	8.00 203	3" F	11.6 294	10.56 268	6.20 157	3.75 95.1	10.62 270	25 635
	4" F	428-F	In. mm.	11.75 298	10.75 273	6.47 164	15.75 400	11.00 279	4" F	12.8 325	13.81 350	6.20 157	4.50 114	11.75 298	22 659
	6" F	429-F	In. mm.	17.00 432	15.75 400	7.87 200	20.00 508	14.50 368	6" F	10.9 278	16.94 430	8.81 223	7.25 184	17 432	37 940

**Solenoid Specifications**

**Standard AC voltages:** 115, 230-50 or 60 Hz. Consult factory for other voltages.

**Power consumption:** 9.4 watts ac. Volt amperes: 16 holding, 25 inrush.

**Coil:** Class "B" molded, continuous duty. High temperature coils available on request.

**Enclosures:** General-purpose NEMA 1 normally supplied. Explosion-proof and water-tight (NEMA 4, 7 & 9) available, add 1.25"

\*Float Rods are 18 inches (457mm) long sections. Valves up to 4" size are supplied with two sections. 6" valves are supplied with 3 sections

**Solenoid Operated Valve**

Series AM-4500 (Energize to open)  
 Series AM-4510 (Energize to close)

Series 520-526 equipped with solenoid for control by timer, flow meter, pressure or temperature sensor, liquid level or manual switch. Ideal for automated, continuous process systems. Specify "independent pressure" on purchase order if a separate source of control fluid is used.

**SOLENOID SPECIFICATIONS:**

**Standard AC Voltages:** 115, 230-50 or 60 Hz. Consult factory for other voltages.

**Power Consumption:** 9 watts AC. Volt amperes: 15.6 holding, 24.6 inrush.

**Coil:** Class "B" molded, continuous duty.

**Enclosures:** General purpose NEMA 1 only.

**FLOW RATE (GPM)**

SIZE	3/8"-1/2"	3/4"-1"	1 1/4"-2"	2 1/2"-3"	
<b>SERIES</b>	<b>520</b>	<b>521</b>	<b>524</b>	<b>526</b>	
CV	1	5.5	16	48	130
<b>PRESSURE DROP (PSI)</b>	2	7.7	22.6	63	183
	3	9.5	27.6	83	225
	4	11	32	96	260
	5	12.3	36	107	290
	6	13.4	39.2	117	320
	7	14.5	42.1	127	345
	8	15.5	42.2	135	365
	9	16.5	48	144	390
	10	17.4	50.5	151	410
	15	21.3	62	185	504

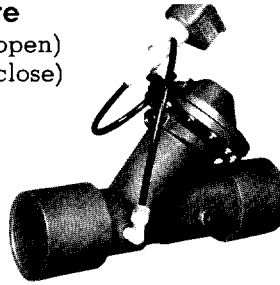
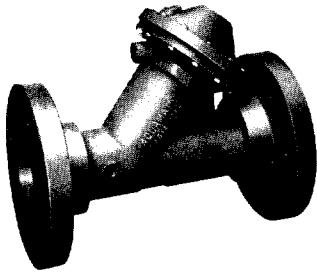

Molded of 30% glass reinforced engineering thermoplastic resin. Line fluid never contacts corrodable surface. *Series 5500* Isolated Bonnet Valves also available.

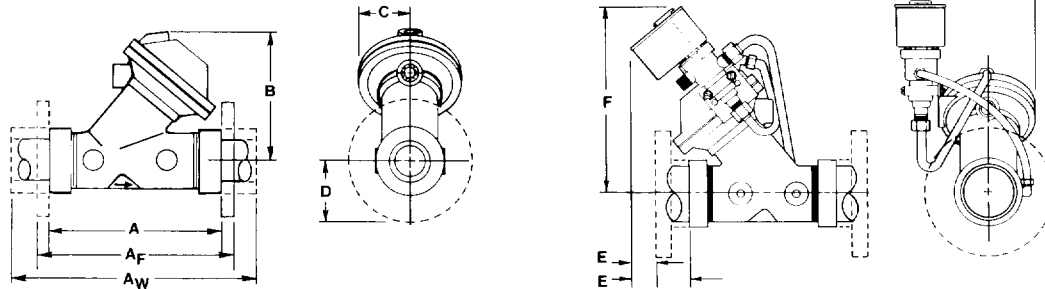

SIZE	SERIES	END CONNECTION		A	AF	AW	B	C	D	E	F	G	H
3/8"-1/2"	520	Ring Nut	In.	3.93			2.62	1.25		1.0	5.87	4.12	
			mm.	99.8			66.5	31.7		25.4	149	105	
3/4"-1"	521	Ring Nut	In.	4.5			4.06	1.62		2.75	6.52	5.12	
			mm.	114.3			103	41.1		69.7	166	130	
1 1/4"-1 1/2"	524	Ring Nut	In.	7.75			5.06	2.28		1.0	7.62	6.25	
			mm.	196.8			128.4	58		25.4	193.5	159	
2"	524F	Flange	In.		9.56		5.06	2.28	3.00		7.62	6.25	7.0
			mm.		242.8		128.4	58	76.0		193.5	159	177
	524W	Female Socket Weld	In.			10.5	5.06	2.28			7.62	6.25	
			mm.			266.7	128.4	58			193.5	159	
	524WA	Male Socket Weld	In.			10.5	5.06	2.28			7.62	6.25	
			mm.			266.7	128.4	58			193.5	159	
2 1/2"	526F	Flange	In.		11.5		7.31	3.12	3.50		9.62	7.87	8.37
			mm.		292.1		185.7	79.2	89.0		244	200	212
	526W	Female Socket Weld	In.			15.0	7.31	3.12			9.62	7.87	
			mm.			381	185.7	79.2			244	200	
3	256F	Flange	In.		12.0		7.31	3.12	3.75	.50	9.62	7.87	8.62
			mm.		304.8		185.7	79.2	95.0	12.7	244	200	218

Notes: Male and female, threaded and socketweld pipe adapters available. See detail below. Flanges drilled per ASA Std. B 16.1.

**Adaptor Dimensions**

VALVE SERIES	DIMEN. UNIT	GROOVE DETAIL				
		LENGTH A	LOCATION B	DIA. C	WIDTH D	THICKNESS E
520	INCHES	2.25	0.50	0.730	0.115	0.147
	MM.	57	12.7	18.5	2.92	3.73
521	INCHES	3.00	0.50	1.200	0.115	0.179
	MM.	76	12.7	30.4	2.92	4.54
524	INCHES	4.00	0.875	1.800	0.115	.200
	MM.	101	22.2	45.7	2.92	5.08

**Remote Float Control**

Direct mounting of float control on plastic valves is *not recommended*. Use Model 348 LC Level Control for remote mounting. See illustration on page 2 of this catalog.

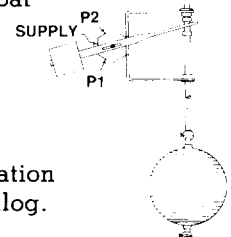

AquaMatic, Inc., 2412 Grant Avenue, Rockford, Illinois 61103-3991 ■ 815/964-9421 ■ Cable "AquaMatic"—Telex 257-355

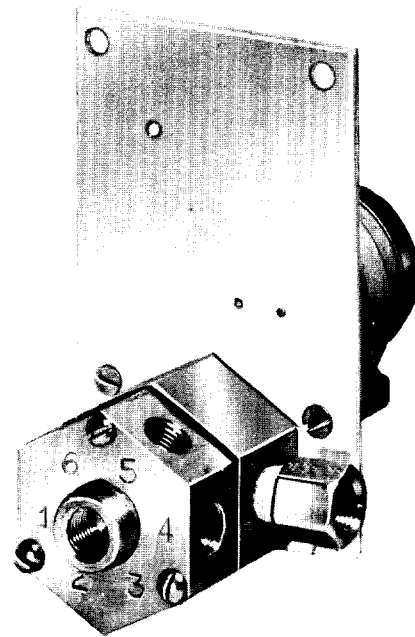
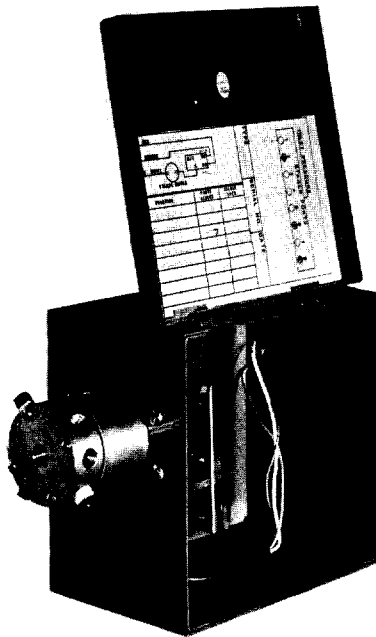
**48 & 51****STAGERS****SERIES 48 & SERIES 51 STAGERS**

A stager is, essentially, a rotary pilot valve with multiple ports through which control fluid is directed, thereby operating diaphragm valves installed in a process system. AquaMatic stagers are constructed of durable, non-corroding, self-lubricating material for long, maintenance free life. They are available in three basic designs: Series 48 with six ports; Series 51 with eight ports; and Series 58 with sixteen ports (see separate bulletin).

Stagers may be manually operated or driven by an electric motor that is operated through an adjustable timer. If, for any reason a motor driven stager is manually indexed, it must be re-synchronized with the timer.

As an optional feature, stagers can be equipped with an electrical switch to energize display lights, or initiate ancillary equipment. Consult factory for details.

The stager functions by opening and closing its ports, singly or in combination, in a sequence that fits the needs of the system. The "positions" in the sequence correspond to the number of "stages" in the process. The ports that are opened when the stager is in any given position allow pressurized fluid to flow to and operate some diaphragm valves, while venting other valves—allowing them to return to their normal positions.

AquaMatic stagers can use either hydraulic or pneumatic control fluid. Process fluid, if pressurized, and not damaging to internal parts of the stager or diaphragm valve, may be drawn from the main line to the

inlet of the stager. Otherwise, an independent source of control fluid is required. The pressure of the control fluid must be equal to or greater than the line pressure of the system.

AquaMatic stagers provide the versatility needed to control complex water treatment systems, or the simplicity of a two valve operation. The system's diaphragm valves are operated by hydraulic or pneumatic pressure (control fluid). Continuous electrical power is not required to maintain the positions of the valves such as in a solenoid operated system. Consequently, the danger of disrupting the process is minimized.

#### Specifications Series 48 and Series 51

Maximum pressure	100 psi (6.8 Atm.)
Maximum temperature	150°F (65°C)
Power port size	1/8"
Inlet, drain ports	1/8"
Electrical supply	120Vac/60Hz 230Vac/50Hz

#### Electrical enclosures:

Standard—NEMA, Type 1	6" x 6" x 4"
Optional—NEMA, Type 12 (Indoor, watertight)	6" x 6" x 4"
Optional—NEMA, Type 4 (Outdoor—watertight)	6" x 6" x 4"

WHEN ORDERING, specify stager model, valve programming requirements, electrical specifications, and type of enclosure.

**AquaMatic**®

2412 Grant Avenue, Rockford, Illinois 61101 ■ 815/964-9421 ■ Cable "Aqua-Matic"—Telex 257-355

# AquaMatic

## STAGERS

### Typical Circuit Applications for Series 48 and Series 51 Stagers

Piping fitted with AquaMatic diaphragm valves which are operated by pressurized control fluid from stager pilot. 1/4" O.D. flexible tubing connects stager ports to diaphragm valves. When water is turbid, or contains high iron content, a cartridge filter should be placed ahead of stager inlet port.

Tables show which valves are open at each stager position.

#### MODEL 48-0

STAGER POSITION	SOFTENER FUNCTION	VALVES OPEN
4	SERVICE	1, 2
1	BACKWASH	3, 4, (2A)
2	BRINE	5, 6, (2A)
3	FAST RINSE	6, 1, (2A)

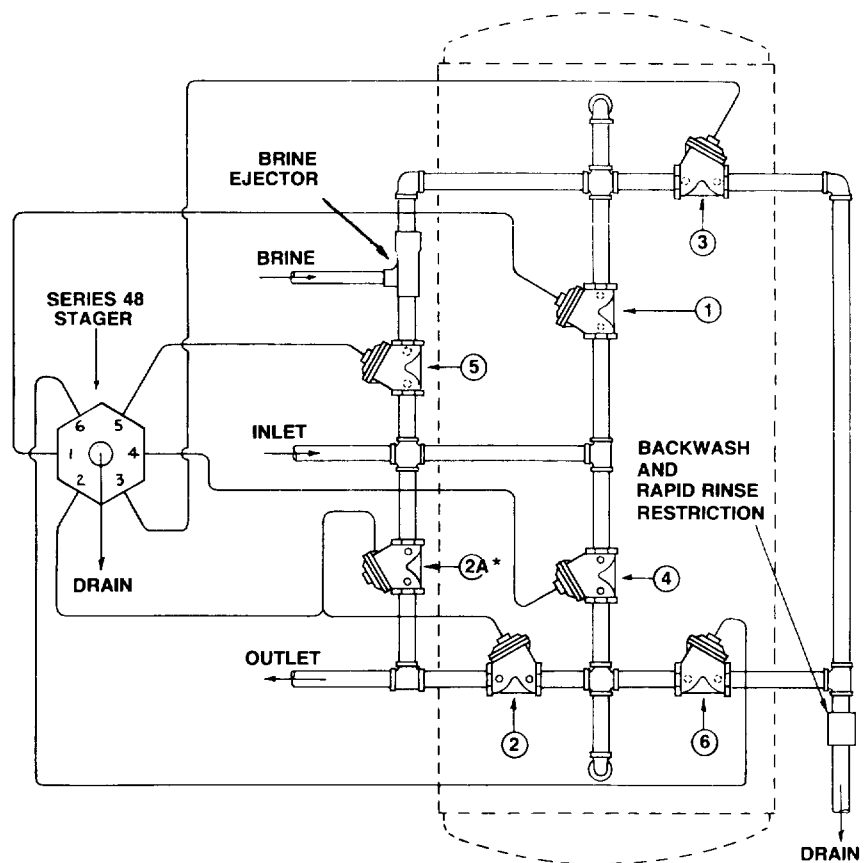

#### MODEL 51D-6 (Timed brine & refill.)

STAGER POSITION	SOFTENER FUNCTION	VALVES OPEN
1	BACKWASH	3, 4, (2A)
2	BRINE	5, 6, 7, (2A)
3	SLOW RINSE	5, 6, (2A)
4	FAST RINSE	1, 6, (2A)
5	BRINE REFILL	1, 2, 8, (2A)
0	SERVICE	1, 2

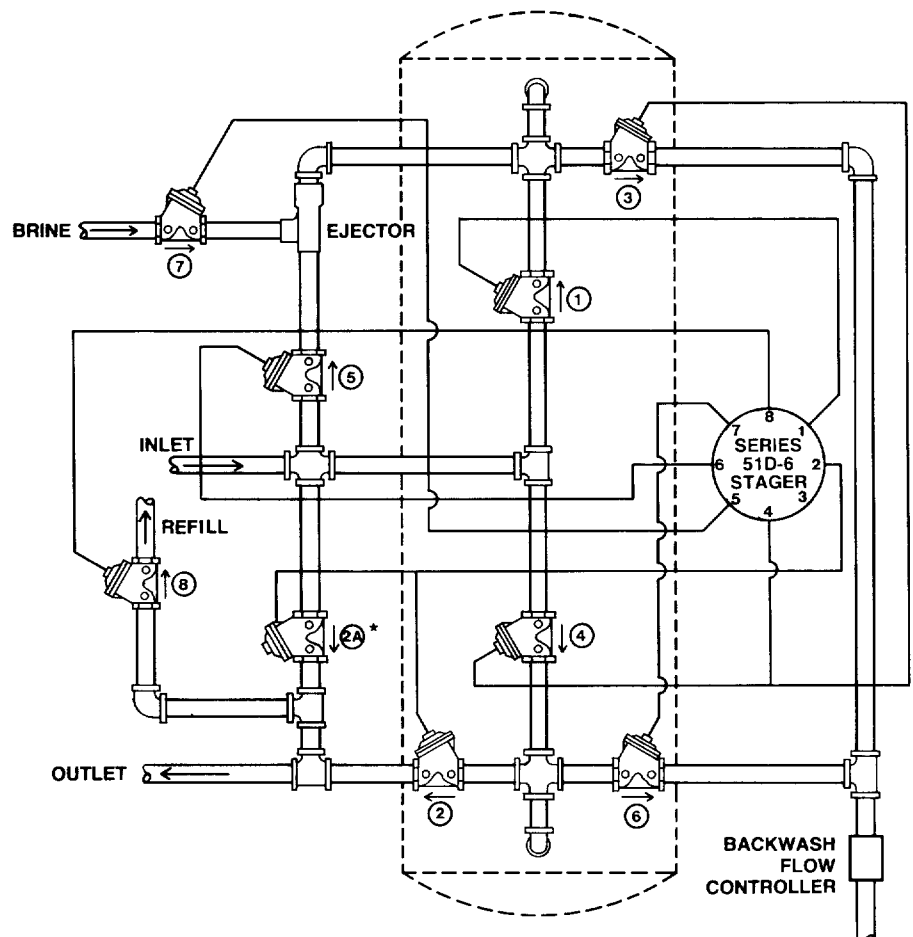

\*Note: Valve 2A is optional; provides raw water service during regeneration.

**AquaMatic**®

2412 Grant Avenue, Rockford, Illinois 61101 ■ 815/964-9421 ■ Cable "Aqua-Matic"—Telex 257-355

# BADGER INDUSTRIAL TURBO METERS

## SIZES 2" TO 6"

Turbo Meter  
With Pneumatic  
Batching Register

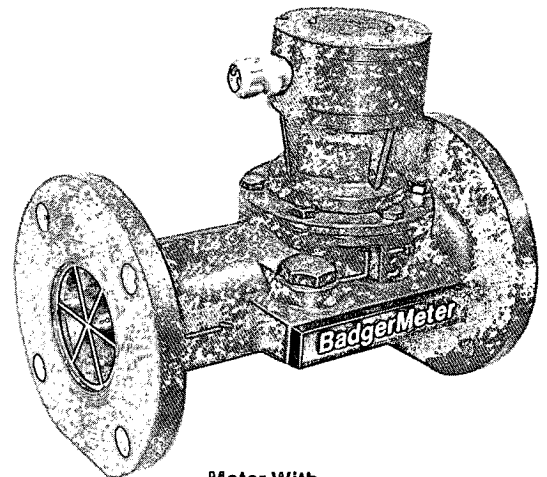
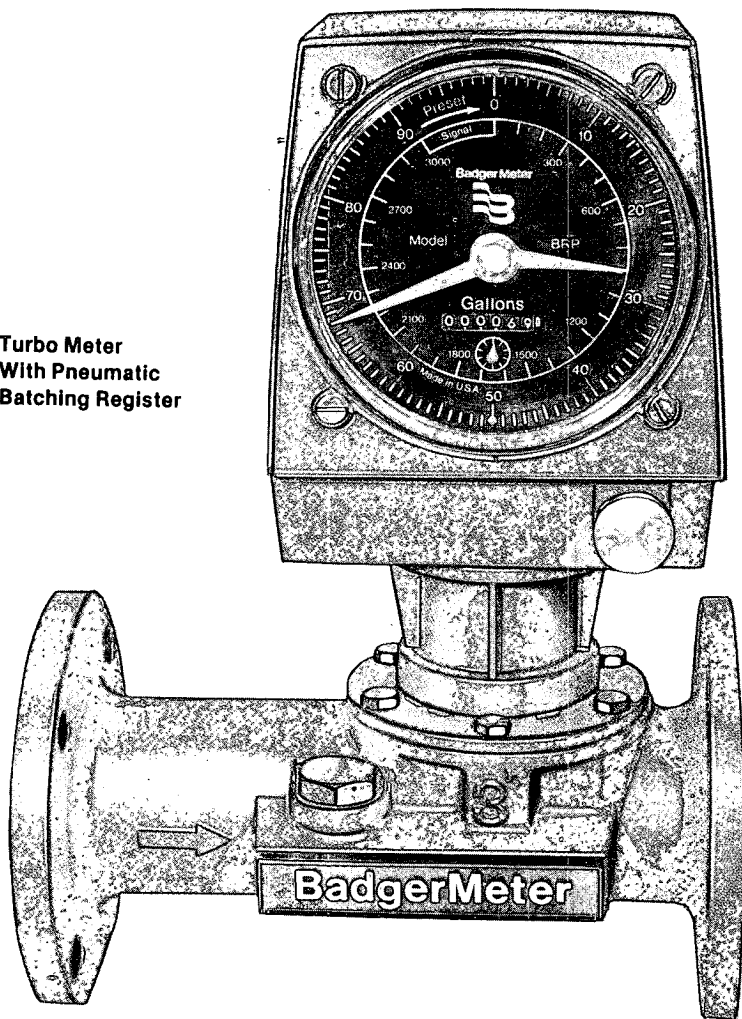

Meter With  
Pulse Transmitter

**HIGH ACCURACY OVER  
BROAD FLOW RANGE**

**COMPACT**

**LIGHTWEIGHT**

**Badger Meter, Inc.** Industrial Products Division  
4545 W. Brown Deer Road, P.O. Box 23099  
Milwaukee, WI 53223 (414) 355-0400



# MAGNETIC DRIVE TURBO METERS... HIGH ACCURACY OVER BROAD FLOW RANGE

Badger's magnetic drive turbo meters provide industrial processors with higher accuracy over a broader flow range than traditional turbine meters with vertical rotors.

Accuracy of the turbo meter can be maintained within  $\pm 1\frac{1}{2}\%$  over the meter's entire flow range—not just at one point. Repeatability is within  $\frac{1}{2}$  of 1%.

The straight-through flow design makes it possible to operate the turbo at a higher continuous flow than a comparable turbine. In addition, the low flow range on most models is extended about 50% below the minimum for vertical-rotor turbines.

Because of the magnetic drive design, Badger turbo meters also help to reduce maintenance problems. There are no gears in the flow stream, no packing glands to cause leaks.

Badger turbo meters are offered in four different housing materials for measuring liquids up to 250°F. They can handle a wide variety of chemical solutions, paper coating materials, oils, water and food ingredients.

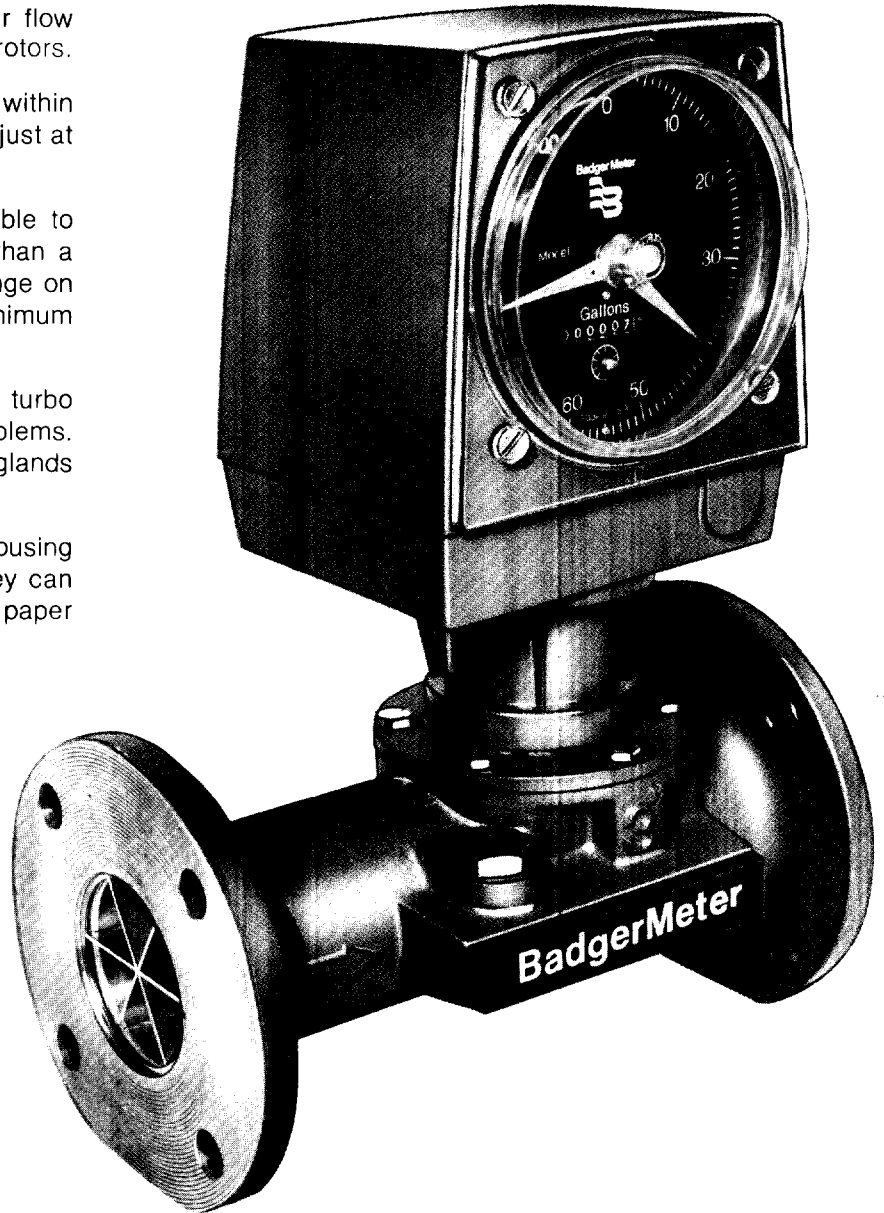

## WIDE FLOW RANGE METERING CAPABILITY

METER SIZE	FLOW RANGE—G.P.M.*		MAXIMUM CONTINUOUS FLOW
	MINIMUM	MAXIMUM	
2"	8	160	160
3"	10	350	350
4"	25	1000	1000
6"	40	2000	2000

\*Consult your Badger representative about accuracy performance above and below flow rates shown.

## OPERATING PRINCIPLE

Badger's turbo meter, with straight-through flow design, is equipped with straightening vanes and a nose cone at the inlet side. These minimize the swirling effect of upstream piping.

Liquid flowing through the meter tube strikes the blades of a rotor, causing the rotor to turn. By means of a magnetic coupling, this motion is transferred to a vertical spindle and then to gears in the meter's register.



**LONG-WEARING CERAMIC BEARINGS**

The rotor bearing, rotor spindle and endstone in the Badger turbo meter are made of a ceramic material developed especially for this application. Because of their hardness, the ceramic parts provide long-life service, even if the meter is run continuously at maximum flow.

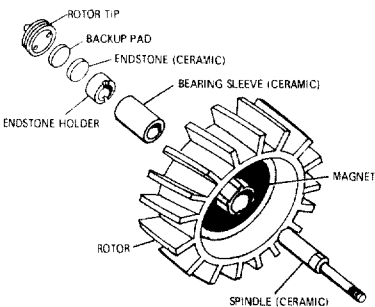

**COMPACT, LIGHTWEIGHT... EASY TO INSTALL**

Badger turbo meters are easy to install and service because of their compact size and light weight. A 3" turbo meter, for example, weighs just 40 pounds compared with more than 300 pounds for a vertical-rotor turbine. The laying length is only 12".

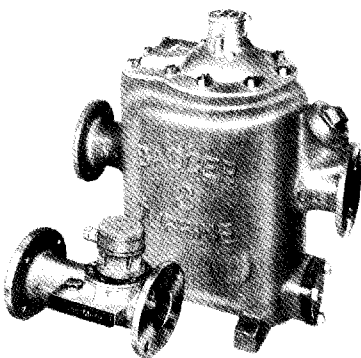

**SERVICE WITHOUT REMOVAL FROM LINE**

For easy servicing, the rotor and head assembly in the turbo meter can be removed without disconnecting the meter from the line. Just loosen the head bolts on top of the housing and lift out the entire assembly.



**ON-SITE CALIBRATION**

A convenient bypass valve, for precise calibration, is built into the bronze and cast iron housings of 2" and 3" meters. Simply remove the locking nut and turn the valve with a screwdriver to adjust flow.

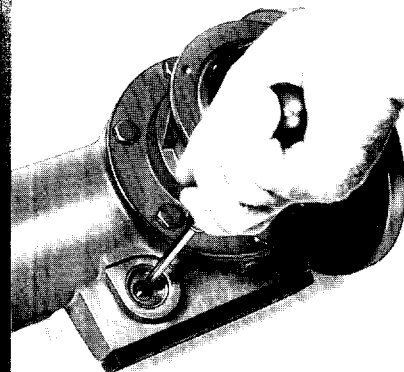

**WIDE CHOICE OF REGISTERS AND ACCESSORIES**

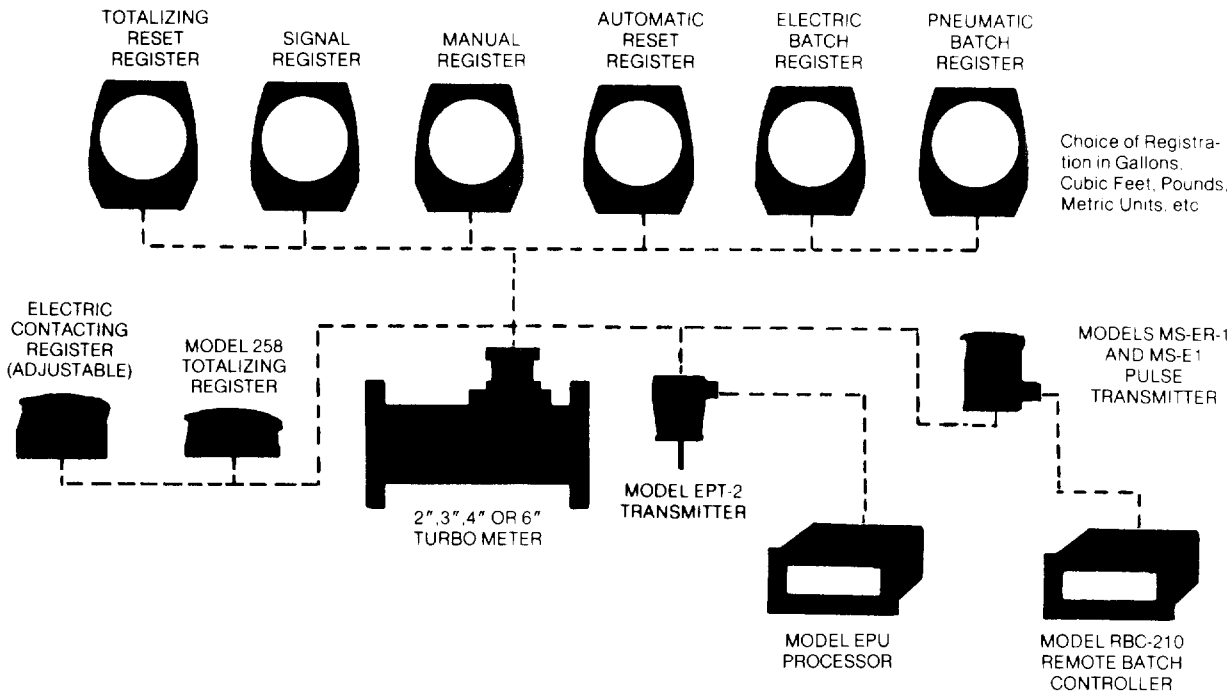

**MATERIALS**

Housing.....	316 Stainless
.....	Cast Iron
.....	Cast Steel
.....	Cast Bronze
Rotor and Nose Cone, 2" through 6" .....	Ryton
.....	Kynar
Rotor Bearing, Spindle and Endstone.....	Ceramic
Magnet.....	Ceramic
Straightening Vanes .....	316 Stainless
Register Base.....	Aluminum
Bypass Valve .....	316 Stainless—2" and 3" Meters
Head Gasket .....	Nonasbestos/Nitrile Binder
.....	Nonasbestos/Chloroprene Binder
.....	Asbestos/Special Binder
"O" Ring and Tetraseal .....	EPR, Buna N or Viton A

**ADDITIONAL ACCESSORY INFORMATION**

MODEL	DESCRIPTION	BULLETIN NO.
BRE	Batch Register, Electric	IBR-3010
BRP	Batch Register, Pneumatic	IBR-3010
MR	Batch Register, Manual	IBR-3010
AR	Automatic Reset Register	IAR-3011
SR	Signal Register	IAR-3011
TR	Totalizing Reset Register	ITR-3012
EC-A	Electric Contacting Register	REC-5009
RBC	Remote Batch Controller	IRC-3009
MS-ER1	Pulse Transmitter	XP-6011
MS-E1	Pulse Transmitter	XP-6008
EPT&EPU	Electronic Transmission System	IEP-3013

**LOW PRESSURE LOSS**

Badger turbo meters operate with less pressure loss than turbines with vertical rotors. The pressure loss curves on adjoining chart were calibrated without a strainer ahead of the meter. Since many different strainers can be applied, industrial processors should be aware that system pressure drop could result.

**INDUSTRIAL TURBO METER PRESSURE LOSS CHART**

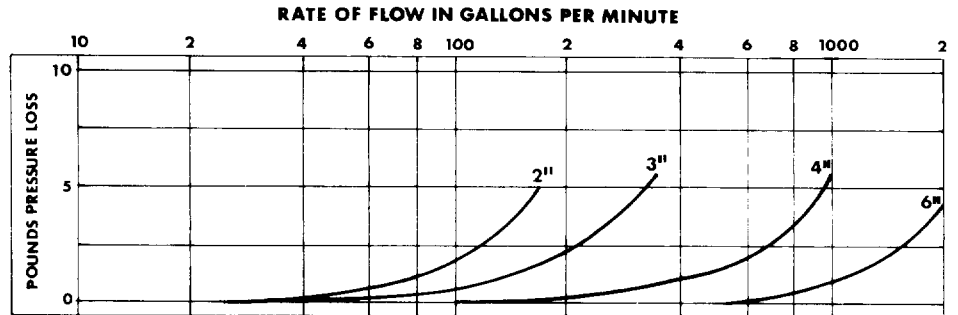

**WHEN ORDERING**

Specify turbo meter size (flow range) and type of housing material (for compatibility with liquid).

When ordering meter with register, specify model of register and unit of measure. If BRE or BRP batch register is required, specify dial capacity.

When ordering meter with pulse transmitter, specify pulse/unit of measure. Please also list RBC-210 remote batch controller, electric contacting or totalizing/reset register or electronic transmission system if required.

SPECIFICATIONS	2"	3"	4"	6"
Accuracy — Entire Flow Range.....	± 1.5%	± 1.5%	± 1.5%	± 1.5%
Repeatability — Constant Flow and Temperature .....	± 0.5%	± 0.5%	± 0.5%	± 0.5%
Head Loss — Maximum Flow (PSI).....	4.5	6	5.5	5.5
Maximum Operating Temperature (°F).....	250	250	250	250
Maximum Operating Pressure (PSI).....	150 Std. 300 Opt.	150 Std. 300 Opt.	150 Std. 300 Opt.	150 Std. 300 Opt.
Approx. Weight (Lbs.) with 150 PSI Conn. (Depends on Meter Material Selected)....	30-40	40-50	60-75	100-125
Laying Length (Inches).....	10	12	14	18
Height — w/o Register (Inches).....	8	9	10	12
Connection Flanges .....	Round	Round	Round	Round

**WARRANTY**

Badger warrants meters and parts manufactured by it and supplied hereunder to be free from defects in materials and workmanship for a period of 18 months from date of shipment or 12 months from date of installation, whichever period shall be shorter. If within such period any meters or parts shall be proved to Seller's satisfaction to be defective, such meters or parts shall be repaired or replaced at Seller's option. Seller's obligation hereunder shall be limited to such repair and replacement and shall be conditioned upon Seller's receiving written notice of any alleged defect within 10 days after its discovery and, at Seller's option, return of such meters or parts to Seller f.o.b. its factory. THE FOREGOING WARRANTY IS EXCLUSIVE AND IN LIEU OF ALL OTHER EXPRESS OR IMPLIED WARRANTIES WHATSOEVER INCLUDING BUT NOT LIMITED TO IMPLIED WARRANTIES (EXCEPT OF TITLE) OF MERCHANTABILITY AND FITNESS FOR A PARTICULAR PURPOSE. Badger shall not be liable for any defects attributable to acts or omissions of others after shipment, nor any consequential, incidental or contingent damage whatsoever.

**NUCLEAR DISCLAIMER**

Equipment sold by Badger Meter, Inc. is not intended for use in connection with any nuclear facility or activity unless covered by a specific quotation where the conditions of such usage will be detailed. If equipment is used in a nuclear facility or activity without a supporting quotation, Badger Meter disclaims all liability for any damage, injury or contamination, and the buyer shall indemnify and hold Badger Meter, its officers, agents, employees, successors, assigns and customers, whether direct or indirect, harmless from and against any and all losses, damages or expenses of whatever form or nature (including attorneys' fees and other costs of defending any action) which they, or any of them, may sustain or incur, whether as a result of breach of contract, warranty, tort (including negligence) strict liability or other theories of law, by reason of such use.

# INSTALLATION OPERATION AND MAINTENANCE MANUAL



**BADGER  
INDUSTRIAL  
TURBO METERS**

**Badger Meter, Inc.** Industrial Products Division  
4545 W. Brown Deer Road, P.O. Box 23099, Milwaukee, WI 53223



## PREFACE

### SCOPE OF THE MANUAL

This manual contains information concerning the installation, operation and maintenance of Badger magnetic drive turbo meters. To ensure efficient operation of the meters, the instructions given in this manual should be thoroughly read and understood. Retain the manual in a location where it is readily available for reference.

### CHANGES IN THE MANUAL

Changes or additions to the original edition of this manual will be covered by a "CHANGE NOTICE" supplied with the manual. The change notice will explain any differences between the turbo meter received and the meters described in this manual.

## SECTION I

### GENERAL INFORMATION

#### 1-1. GENERAL DESCRIPTION

Badger's industrial turbo meters, available in sizes from 2" through 6", utilize a straight-through flow design to provide high accuracy over a broad flow range. Meter housings are offered in four different materials for measuring chemical solutions, water and other liquids at temperatures up to 250° F. The meters are designed for use with a variety of meter-mounted accessories such as registers or pulse transmitters.

Basic components of the turbo meter consist of the housing, meter operating head, rotor assembly, straightening vanes and register base. In addition, the 2" and 3" sizes have an adjustable bypass valve for on-site calibration.

In the operation of a turbo meter, liquid flows through the straightening vanes and nose cone at the inlet side of the meter so that the swirling effect of upstream piping is minimized. The liquid then strikes the blades of a rotor, causing the rotor to turn.

By means of a magnetic coupling, the rotor's motion is transferred to a vertical spindle and then to gears in the meter's register or pulse transmitter. The magnetic drive eliminates the need for packing glands and minimizes the number of parts that come in contact with the liquid being metered.

Each complete revolution of the rotor is directly proportional to a specific volume of liquid. The volume measured with each revolution increases with the size of the meter.

#### 1-2. CONFIGURATION AND SPECIFICATION DATA

Tables 1-1 provide a summary of configuration and specification data pertaining to Badger's turbo meters for industrial applications. As indicated in the tables, there are four standard meter sizes – 2", 3", 4" and

6". In addition, each meter size is available with four different housing materials – 316 stainless steel, cast iron, cast steel and cast bronze.

The differences between the meter sizes are characterized by the flow range, head loss, laying length and weight. The differences between configurations are characterized by the flange connections, accessories and the type of housing material that is compatible with the liquid to be metered. When reviewing the specifications, it is important to note that all flow data is based on water or liquid with the same specific gravity and viscosity as water at ambient temperature.

#### 1-3. APPLICATIONS

The size and configuration of the turbo meter selected for use in a liquid metering application is determined, primarily, by the flow and physical characteristics of the liquid to be metered, i.e., rate of flow, operating pressure, temperature, viscosity and chemical composition of the liquid. These meters can, for example, handle a variety of chemical solutions, paper coating materials, oils, water and food ingredients.

#### NOTE

When ordering a turbo meter, it is important that the type of housing material will be compatible with the liquid or chemical solution to be metered. In addition, the rotor magnet must be compatible with the type of transmitter selected.

For applications relative to a specific liquid, refer to Badger's Application Note AN-10. If you have questions, contact your local Badger Meter representative or the Industrial Products Division, Badger Meter, Inc. (address on title page).

# SERVICE NOTE

## Number 16

**SCOPE:** This service note provides instructions for removing and installing the gear train assembly with magnet located in the register base of 2" through 6" industrial turbo meters.

**PURPOSE:** The gear train assembly can be removed and replaced without removing the turbo meter from the line and the register base from the operating head assembly.

Two gear train assemblies are used with industrial turbo meters. To find out what the gear train ratio is, count the number of spindles (gear and pinions) that protrude through the five mounting holes provided in the top plate of the gear train assembly. If there are only three spindles, the gear ratio is 366:1 and if there are five spindles, the gear ratio is 1200:1.

### INSTRUCTIONS FOR REMOVING THE GEAR TRAIN ASSEMBLY WITH MAGNET

1. Remove the register, transmitter or adapter mounted on the register base. A screwdriver, pliers or small box wrench can be used to remove the mounting bolts (or screws) securing the accessory to the base.

2. To remove the gear train from the register base of molded plastic, use a small screwdriver and loosen three screws and special washers located on the top plate of the gear train assembly.

3. Turn each washer until the flat edge frees the washer from the groove on the inside wall.

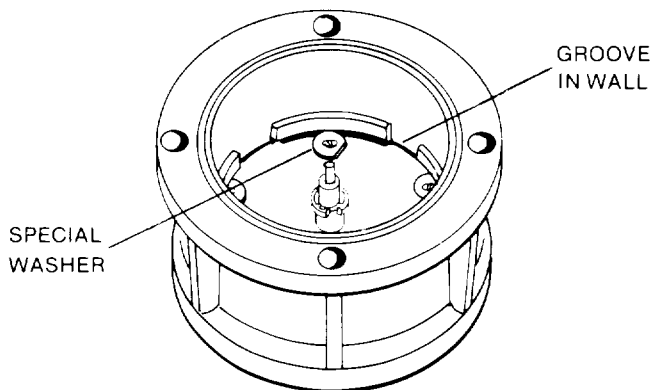

Turn each washer to free it from the groove on the inside wall.

Turbo meters with an aluminum register base have a clip-type retainer ring to secure (or lock) the gear train assembly in the base. Use a small screwdriver to release the retainer ring from the groove in the wall adjacent to the top plate of the gear train assembly.

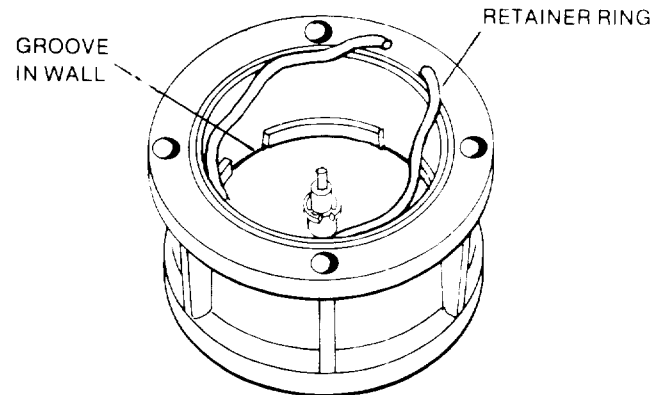

Release the retainer ring from the groove to free the gear train assembly from the base.

4. Grip the change gear spindle and lift to remove the gear train assembly with magnet from the register base.

5. Remove the accessory change gear or coupling from the gear train spindle. Before removing, note the location of the change gear (or coupling) on the spindle so that it can be reinstalled in the same location.

#### NOTE

A flat surface is provided at the top of the spindle of the change gear assembly so that the setscrew in the change gear or coupling can be properly seated and tightened to the spindle.

6. Gear train assemblies are packaged with the magnet and spindle assembly disassembled from the gear train assembly. Before assembling, carefully check the spindle for minute burrs on the threaded end of the spindle. If there are burrs, use a crocus cloth and carefully remove them from the spindle. This will prevent damage to the surface of the jewel bearing when



**Badger Meter, Inc.** Industrial Products Division

4545 W. Brown Deer Road, P.O. Box 23099, Milwaukee, WI 53223

inserting the magnet spindle through the jewel-bushing in the bottom plate of the gear train assembly. An "E" ring should be mounted on the spindle. If missing, remove the "E" ring from the replacement spindle and snap it into the grooved collar near the threaded end of the spindle.

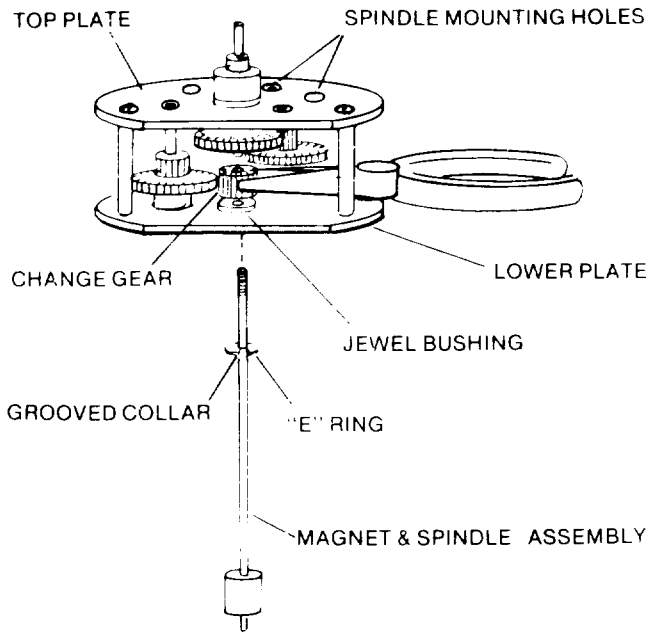

**Installing the magnet spindle assembly to the gear train assembly.**

**NOTE**

On 366:1 and 1200:1 gear train assemblies, the magnet and spindle assembly (P/N 56780-002) is installed by removing the threaded gear (P/N 30229-000) from the spindle. Using a needle-nose pliers, grip the gear on the side and hold it on top of and at the center of the jewel bushing located in the bottom plate of the gear train assembly. Insert the threaded end of the spindle through the bushing and into the threaded gear. Turn the spindle to tighten it to the gear.

**INSTRUCTIONS FOR INSTALLING THE GEAR TRAIN ASSEMBLY WITH MAGNET**

1. Align the gear train assembly with magnet so that the magnet and spindle can be easily lowered into the shaft of the register base.

2. Rotate the gear train assembly until it seats into each boss provided at the base. This configuration aligns the three special washers on the top plate of the gear train with the shoulder extensions on the inside wall.

With the aluminum register base, the gear train assembly seats in three recessions in the register base. These recessions align with three gear train posts that support the top and bottom plate of the gear train assembly.

3. Loosen the three screws and special washers on the top plate. Using a screwdriver, turn each washer until the round edge locks under the shoulder extension. Tighten each screw which secures the gear train assembly in the register base.

The retainer ring secures the gear train assembly in the aluminum register base. With the gear train properly seated in the base, insert the retainer ring in the groove provided in the wall. The groove is adjacent to the top plate of the gear train assembly.

4. Reinstall the change gear or coupling on the gear train spindle. Align the setscrew in the gear or coupling with the flat surface on the spindle and tighten.

5. Mate the change gear or coupling to the register or transmitter and install the accessory on the register base.

6. Reinstall the accessory mounting bolts (or screws) and tighten.

7. Test operate the meter to check the accuracy of the register or transmitter with the replacement gear train assembly.

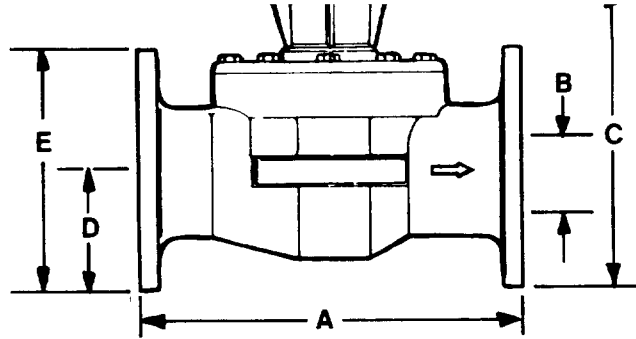

METER SIZE	CONNECTION FLANGES	DIMENSIONS (INCHES)					MAX. OPERATING PRESSURE (PSI)	MAX. OPER. TEMP. (°F)	CONFIGURATIONS		
		A	B	C	D	E (WIDTH)			HOUSING MATERIAL: 316 Stainless, Cast Iron, Cast Steel & Cast Bronze		HEAD LOSS AT MAX. FLOW (PSI)
		NORMAL FLOW RANGE (GPM)	MAX. CONT. FLOW (GPM)								
2"	Round	10	2	8	2 3/4	6	150 Std. - 300 Opt.	250	8 - 160	160	4.5
3"	Round	12	3	9	3 1/2	7 1/2	150 Std. - 300 Opt.	250	10 - 350	350	6.0
4"	Round	14	4	10	4 1/4	9	150 Std. - 300 Opt.	250	25 - 1000	1000	5.5
6"	Round	18	6	12	5 1/4	11	150 Std. - 300 Opt.	250	40 - 2000	2000	5.5

METER HOUSING MATERIAL	ROUND FLANGE CONNECTION		METER WEIGHT — POUNDS (Approx.)							
			2"		3"		4"		6"	
	150 psi	300 psi	150 psi	300 psi	150 psi	300 psi	150 psi	300 psi	150 psi	300 psi
316 STAINLESS	R.F.	R.F.	40	50	50	65	60	80	115	145
CAST IRON	F.F.	R.F.	30	36	40	52	70	90	100	130
CAST STEEL	R.F.	R.F.	40	50	50	65	60	80	115	145
CAST BRONZE	F.F.	F.F.	30	36	40	52	75	95	125	160

R.F. = Raised Face      F.F. = Flat Face

**OVERALL DIMENSION — TURBO METERS WITH ACCESSORIES**

ACCESSORY	MODEL	APPROX. HEIGHT (Inches)			
		2"	3"	4"	6"
Pulse Transmitter	EPT-2	12 1/8	13 1/8	14 1/8	16 1/8
	MS-ER1	13 1/8	14 1/8	15 1/8	17 1/8
Low Profile Register	258	9 1/8	10 1/8	12	15
Series 76 Registers	BRE, BRP, AR, MR, SR & TR	16*	17*	20 1/8	22 1/2
Read-o-Matic	ROM 570	13 1/8	14 1/8	15 1/8	17 1/8
Electric Contacting Register, Adjustable	EC-A	11 1/8	11 1/8	14	16

\*Allow additional 7 1/4" clearance for removing register housing.

**TURBO METER MATERIALS**

COMPONENT PARTS	MATERIAL
Housing .....	316 Stainless Cast Iron Cast Steel Cast Bronze
Rotor .....	Kynar Ryton
Nose Cone .....	Kynar
Rotor Bearing, Spindle and Endstone .....	Ceramic Ceramic
Operating Head .....	316 Stainless
Straightening Vanes .....	316 Stainless
Register Base .....	Aluminum
Bypass Valve .....	316 Stainless
(2" and 3" meters)	
Operating Head Gasket .....	Asbestos/ Special Binder
	Nonasbestos Nitrile, Chloroprene Binder
"O" Ring and Tetraseal .....	EPR Buna N Viton A

Tables 1-1. Configuration and Specification Data for 2" through 6" Turbo Meters

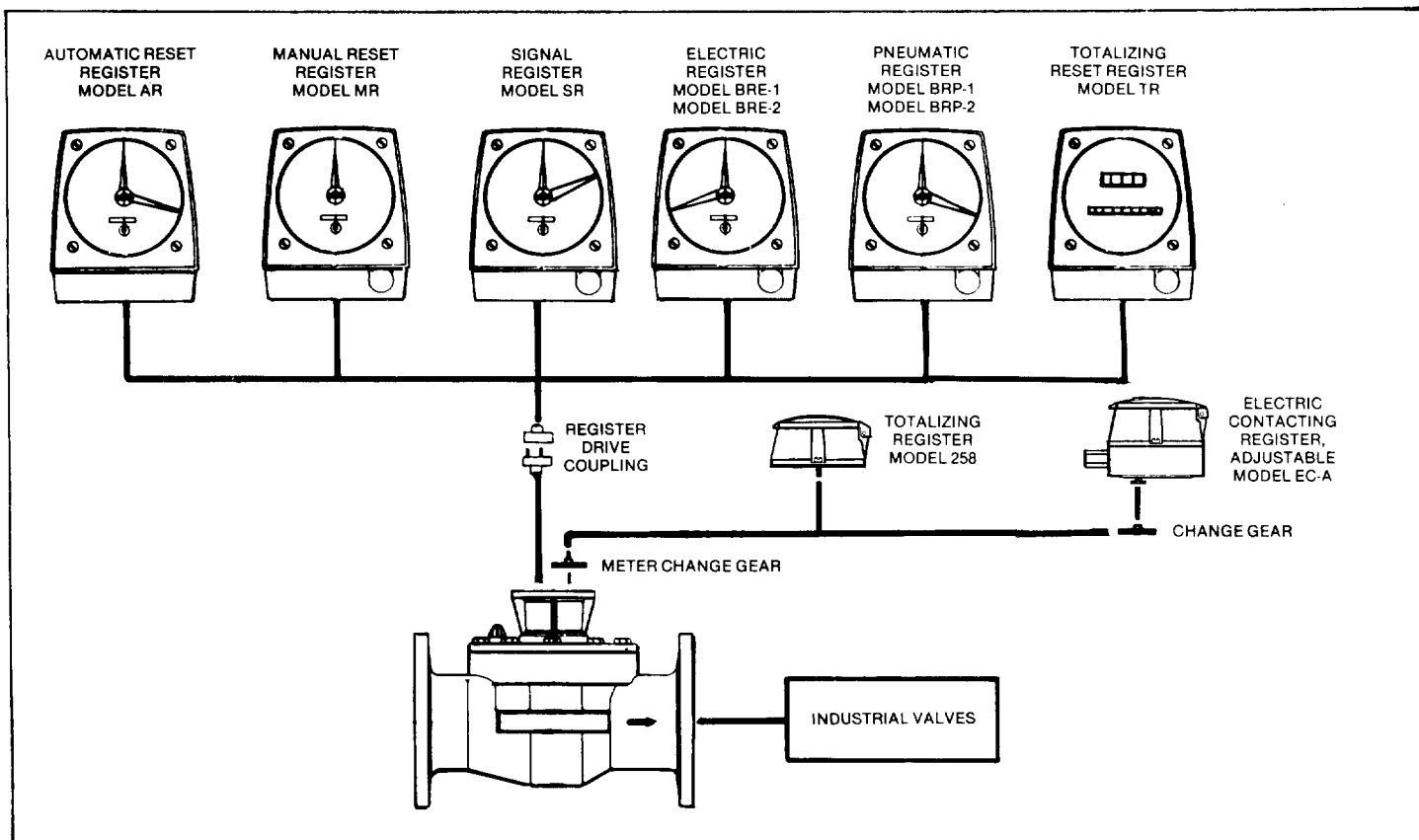

Figure 1-1. Meter-Mounted Accessories for Turbo Meters

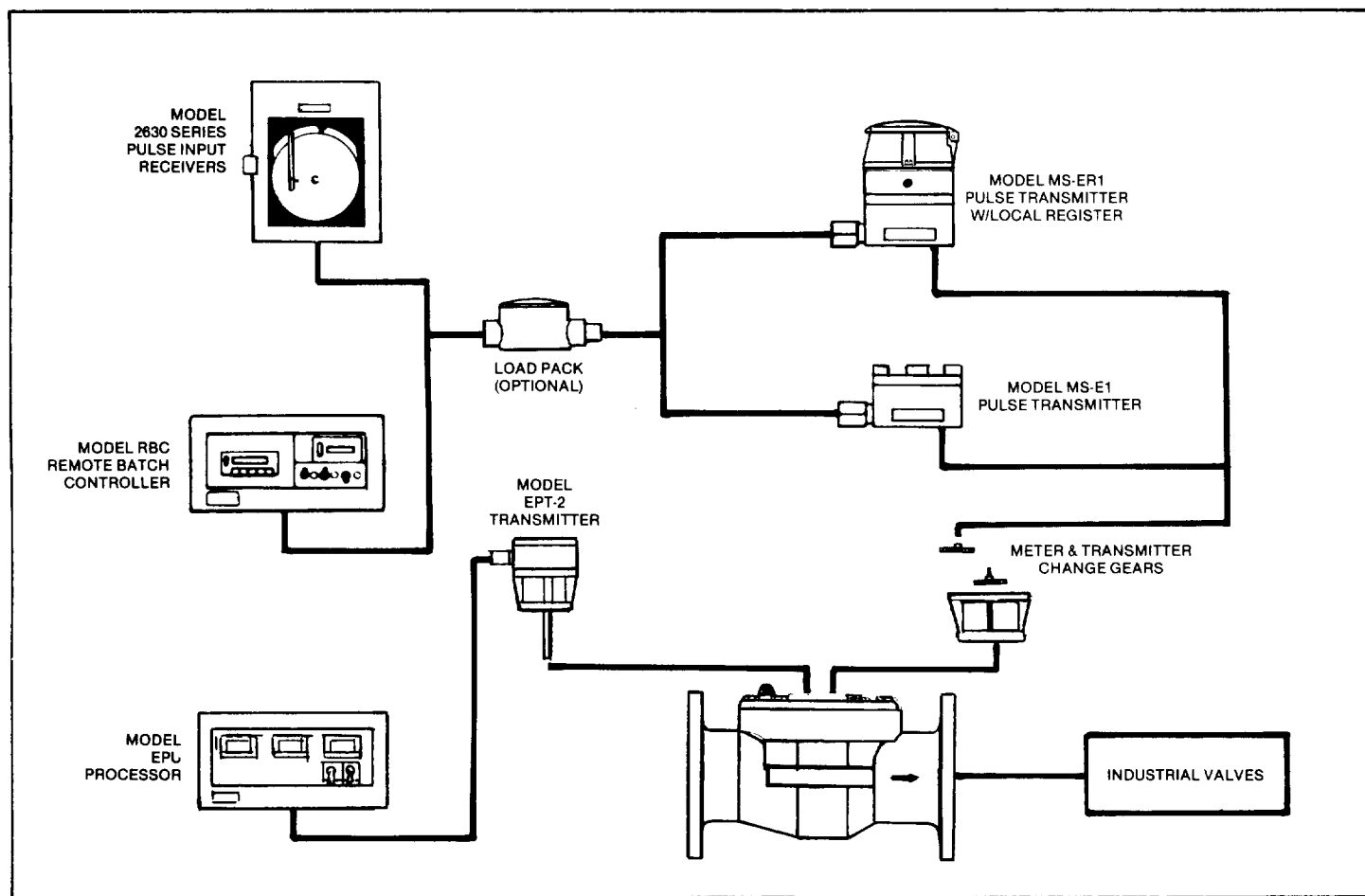

Figure 1-2. Remote Instruments and Controls



#### 1-4. ACCESSORIES

A meter-mounted and driven accessory device such as a register or pulse transmitter must be used with Badger turbo meters to obtain a visual and/or signal output that is directly proportional to the volume of liquid flowing through the meter. Figure 1-1 illustrates the many meter-accessory combinations available. Figure 1-2 indicates the remote instruments and con-

trols that are available. When using the EPU processor, the meter is furnished with an EPT-2 transmitter and the Kynar or Ryton rotor has a four-pole magnet. For detailed information (such as function, dial capacities, unit of measure, pulse rates, etc.) regarding any of the accessories shown, contact your local Badger Meter representative or the Industrial Products Division of Badger Meter, Inc.

## SECTION II INSTALLATION

### 2-1. UNPACKING AND INSPECTION

To avoid damage in transit, Badger turbo meters are shipped to the customer in special shipping containers. Upon receipt of the order, perform the following unpacking and inspection procedures:

#### NOTE

If damage to a shipping container is evident upon receipt of a meter, request the carrier to be present when the meter is unpacked.

- a. Carefully open the shipping container following instructions that may be marked on the container. Remove all cushioning material surrounding the meter and carefully lift the meter from the container.

Retain the container and all packing material for possible use in reshipment or storage.

- b. Visually inspect the meter and applicable accessory device for any physical damage such as scratches, loose or broken parts or other signs of damage that may have occurred during shipment.

#### NOTE

If damage is found, request an inspection by the carrier's agent within 48 hours of delivery. Then file a claim with the carrier. A claim for equipment damaged in transit is the responsibility of the customer.

### 2-2. INSTALLATION

The procedures for installing Badger turbo meters are essentially the same for all meter sizes. Any special instructions required for the installation and/or electrical connection of meter-mounted or free-standing accessory devices such as registers, pulse transmitters, valves and remote batch controllers will be provided as a supplement to this manual.

- a. **PRELIMINARY CONSIDERATIONS.** Before proceeding with the installation, read the instructions given in the following paragraphs to become familiar with the requirements and procedures involved.

#### NOTE

Badger's 2" through 6" industrial turbo meters are designed for operation in HORIZONTAL piping arrangements.

1. Verify that the operating temperature range of the meter is compatible with the temperature range of the liquid to be metered. These meters can be used to meter both cold and hot liquids up to 250 degrees fahrenheit.
2. Ensure that the flow range of the meter coincides with the flow rate of the liquid to be metered. Refer to Tables 1-1 in Section I of this manual for the applicable meter flow range specification data.

#### CAUTION

The life of the turbo meter will be impaired if operated at flow rates higher than specified.

3. If solid material is present in the liquid to be metered, a strainer must be installed in the facility piping upstream of the meter. The 2", 3" and 4" meters require a strainer with  $\frac{1}{16}$ " diameter holes and the 6" meter requires a strainer with  $\frac{1}{8}$ " diameter holes.
4. Avoid locating the meter in close quarters. Allow sufficient space to permit access for cleaning and maintenance.
5. To permit periodic cleanout of the meter and to provide a convenient means of stopping fluid flow during maintenance, it is recommended that a flushing system be incorporated into the facility piping arrangement (see Figure 2-1).
- b. **INSTALLING THE METER.** Badger turbo meters are designed for horizontal, in-line installation. The overall dimensions (including laying lengths) of each of the meter sizes are given in Tables 1-1 in Section I of this manual. After reviewing the applicable dimensional requirements, proceed as follows:

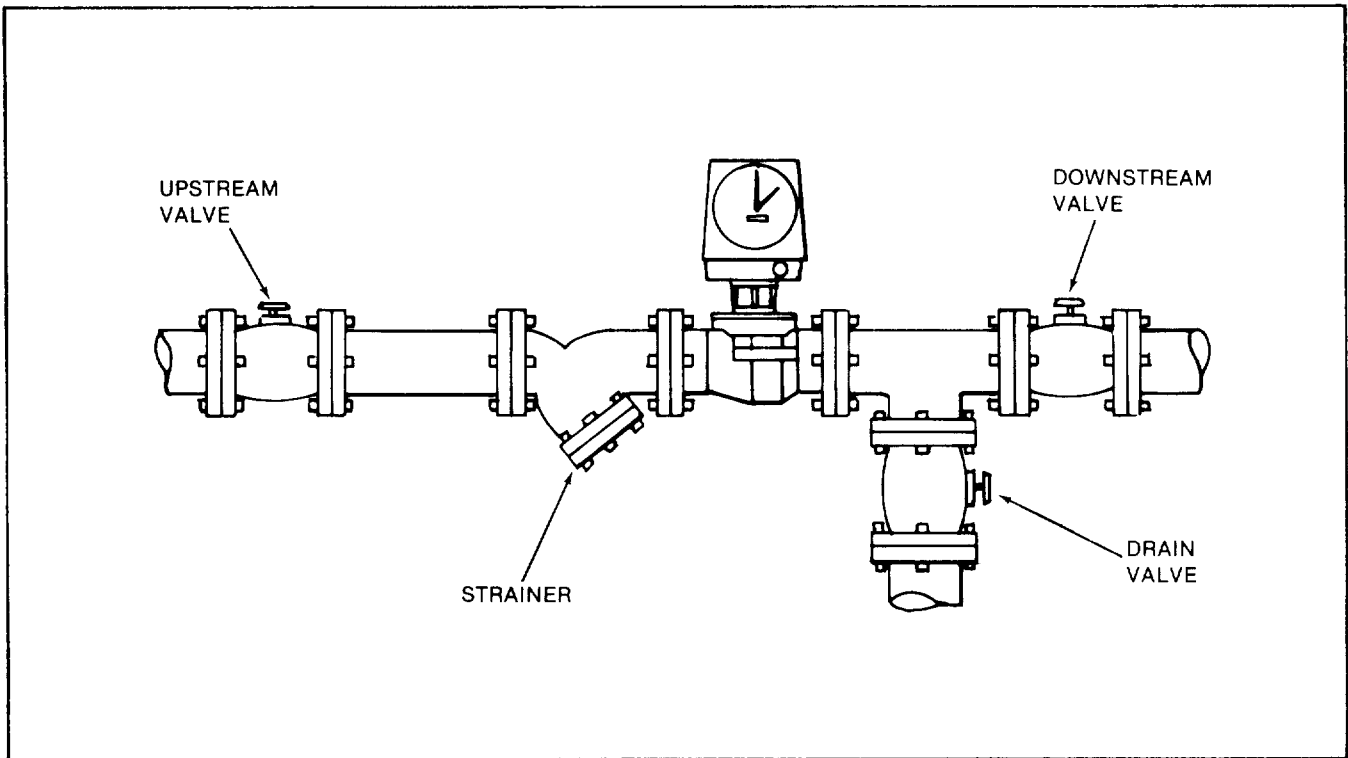

**Figure 2-1. Typical Turbo Meter Installation with Flushing System**

1. Measure the overall length of the meter with the gaskets attached to the inlet and outlet flange connections of the turbo meter.
2. Provide proper gap length in the facility piping.
3. Install the meter in the pipeline making sure that the flow arrow on the meter housing is in proper relation to the direction of liquid flow.
4. Install and tighten the flange connection bolts.
5. To relieve possible strain on the piping due to the weight of 4'' and 6'' turbo meters, it is

recommended that a meter support be installed under the meter housing.

### 2-3. PERFORMANCE

Complete the following checks to ensure that the meter is properly installed and operational.

- a. Slowly open the upstream valve to apply liquid pressure to the meter and check the flange connections for possible leaks. Retighten the flange bolts as required.
- b. Perform a functional test of the turbo meter using the adjustment and calibration procedure given in Section IV, Paragraph 4-4 of this manual.

## SECTION III OPERATION

### 3-1. GENERAL OPERATING INSTRUCTIONS

The instructions for operating Badger turbo meters depend on the meter-accessory combination employed and the type of flow control devices used in the facility piping. In general, operation of the meter can be either manually controlled or accessory controlled. Manual operation applies to metering applications em-

ploying hand-operated valves or other manually-activated, flow-regulating devices that are not functionally controlled by a meter accessory device. Accessory controlled operation is used in metering applications involving meter accessories that provide an electronic, electrical or pneumatic signal to activate and/or deactivate a valve or other type of flow control device.

**CAUTION**

Regardless of the operating procedure used, the valves or devices controlling the flow of liquid through the turbo meter must always be opened and closed slowly to prevent shock loads that may damage the meter's rotor assembly.

- a. **MANUAL OPERATION.** Instructions for the manual operation of a turbo meter are limited to the following start and stop procedures. The procedures are intended for use in simple metering applications where the flow of liquid through the meter is controlled by hand-operated valves located in the facility piping upstream and downstream of the meter.
  1. Slowly open the upstream valve and apply liquid to the meter.
  2. Slowly open the downstream valve to initiate metering.
  3. Adjust the downstream valve so that the rate of flow does not exceed the maximum continuous flow rate specification of the meter (Refer to Tables 1-1 in Section I of this manual for the applicable flow rate specification data).

**NOTE**

On meters equipped with an accessory device providing a totalizing indicator, the rate of flow can be quickly checked by timing the number of gallons registered through the meter in one minute.

- 4. To stop metering, slowly close the downstream valve, then close the upstream valve.
- b. **ACCESSORY CONTROLLED OPERATION.** The step-by-step operating procedures used in accessory controlled metering applications are dependent on the specific function of the meter-accessory employed and its electrical or pneumatic interconnection with the flow control device or devices. Refer to the IOM manuals covering the applicable accessories for specific operating instructions (included as a supplement to this manual when required.)

**3-2. SHUTDOWN INSTRUCTIONS**

If the turbo meter is to be shut down for an extended period of time, it is recommended that the measuring chamber be thoroughly flushed to prevent the settling out of undissolved solids or the accumulation of corrosive deposits.

**SECTION IV  
MAINTENANCE**

**4-1. GENERAL**

This section contains information for servicing and maintaining Badger turbo meters. The information consists of preventive maintenance, calibration and service instructions. Exploded views, a parts list and other illustrations are provided as a supplement to the text.

**4-2. MAINTENANCE EQUIPMENT**

The tools and equipment recommended for use in servicing and maintaining turbo meters are listed in Table 4-1. With the exception of a special change gear mesh gage and a calibration test tank, the tools required are the usual compliment of standard hand tools used by plumbers and mechanics.

DESCRIPTION	SPECIFICATION
Tool Kit.....	Std. Mechanics Tools
Truarc Right-Angle Pliers ....	P/N 1549
Change Gear Mesh Gage ....	Badger P/N 21747
Test Tank.....	Calibrated Volume

**Table 4-1. Recommended Maintenance Equipment**

**4-3. PREVENTIVE MAINTENANCE**

The purpose of preventive maintenance for turbo meters is to ensure efficient operation and long life by detecting and correcting any defects before damage or failure occurs to the meter. Preventive maintenance consists of periodic inspection and cleaning procedures. The procedures should be performed at regular intervals and any defects discovered should be corrected before attempting further operation of the meter.

## a. PERIODIC INSPECTION

1. Visually inspect the turbo meter and meter-mounted accessory for missing hardware, loose connections, broken or scratched register lens, damaged wiring or any other signs of wear or deterioration. Repair or replace components as required.
2. Verify that the meter operates at the proper flow rate and pressure. A loss in pressure, coupled with the resulting decrease in flow rate, may indicate the screen in the upstream pipeline is clogged with material and requires cleaning.

## b. CLEANING

1. Clean all dust, dirt, grease, moisture or other foreign material from the exterior of the meter and meter-mounted accessory. Use a dry cleaning solvent or volatile mineral spirits to remove grease or oil. After cleaning, rinse with water and dry thoroughly.
2. If the facility piping arrangement includes a flushing system (See Figure 2-1), shut off liquid flow to the meter and flush the interior of the meter with clean water or other appropriate cleaning fluid to remove any buildup of internal deposits or corrosion.

**4-4. CALIBRATION CHECK AND ADJUSTMENT**

Accuracy of Badger turbo meters is tested at the factory with water. However, since these meters will be used to measure a wide variety of liquids that could vary in viscosity, it may be necessary to recalibrate a meter under operating conditions using the actual liquid. The following instructions are provided to assist the customer in performing an on-site calibration check and adjustment.

## a. ACCURACY TEST

1. Place a test tank of known volume at the output of the meter.
2. Operate the meter until the test tank is filled to a calibrated level. Since the accuracy of the meter may vary slightly with the flow rate, make a test run at the actual flow rate used in the operation.
3. Record the quantity indicated on the meter-mounted accessory.
4. Repeat the test three times and take the average of the readings.
5. Perform the following calculations to determine percent of accuracy of the meter-accessory combination:

$$\frac{\text{Qty. Indicated on Accessory}}{\text{Actual Quantity in Test Tank}} \times 100 = \text{Meter Accuracy}$$

## EXAMPLE 1.

$$\frac{95 \text{ Gallons}}{100 \text{ Gallons}} \times 100 = 95\% \text{ accuracy}$$

In this example the meter-mounted accessory is slow and must be speeded up by a change gear correction.

## EXAMPLE 2.

$$\frac{104 \text{ Gallons}}{100 \text{ Gallons}} \times 100 = 104\% \text{ accuracy}$$

In this example the meter-mounted accessory is fast and must be slowed down by a change gear correction.

- b. CHANGE GEAR CORRECTIONS. If the accuracy test of a turbo meter-accessory combination indicates that an adjustment is required, proceed as follows:

1. Remove the accessory from the register base on the turbo meter. To remove the change gears from the spindles on the register and the register base, loosen the setscrew on the hub of the change gears.

**NOTE**

Both the O.D. dimension (in decimal inches) and the number of teeth are stamped on each gear.

2. Calculate the ratio of existing change gears as follows:

$$\text{Ratio} = \frac{\text{No. of Teeth on Register Change Gear}}{\text{No. of Teeth on Meter Register Base}}$$

3. Calculate the new change gear ratio required by multiplying the ratio of existing change gears by percent-of-meter accuracy determined in section 4-4a.

## EXAMPLE:

$$\text{Existing Change Gear Ratio} = \frac{42 \text{ Teeth}}{43 \text{ Teeth}} = .976$$

$$\text{Meter Accuracy} = 95\%$$

$$\text{Corrected Change Gear Ratio} = .976 \times \frac{95}{100} = .927$$

4. Select a combination of new change gears that match the corrected change gear ratio. If stocked change gears are not available, submit order for change gears to your nearest Badger Meter representative or the Industrial Products Division of Badger Meter, Inc.

**NOTE**

When ordering, give the serial number of the turbo meter which is stamped on the outlet flange of the meter. Specify the meter size and accessory device employed along with the number of teeth and diameter on existing change gears. Specify the corrected change gear ratio.

5. Install the corrected change gears on the register base and register spindles taking care that the correct change gears are assembled to the appropriate spindles (See Figure 4-1). Assemble the register to the register base on the meter. Refer to section 4-7a for instructions covering the proper method of installing and meshing change gears. On meters with 76 Series registers, provision for change gear adjustment is built into the registers. See the applicable register IOM manual for recalibrating instructions.

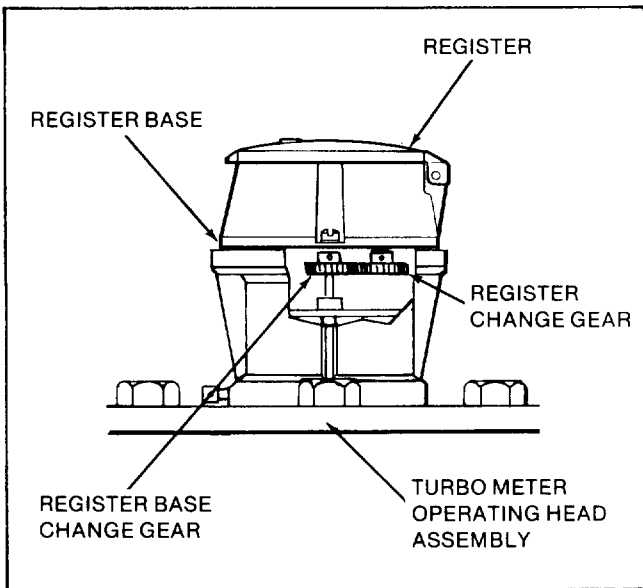

**Figure 4-1. Change Gear Location Register Base and Register Assembly**

**NOTE**

For instructions on removing and installing the gear train assembly in the new and old-style register bases, request Service Note 16. The Service Note explains and illustrates the difference between these two register bases.

#### 4-5. CALIBRATING 2" AND 3" METERS

Badger's 2" and 3" turbo meters with bronze and cast iron housings are equipped with a bypass valve for "minor" calibration adjustment in the field. Test the meter's accuracy to determine if recalibration is required. If the meter is out of calibration, proceed as follows:

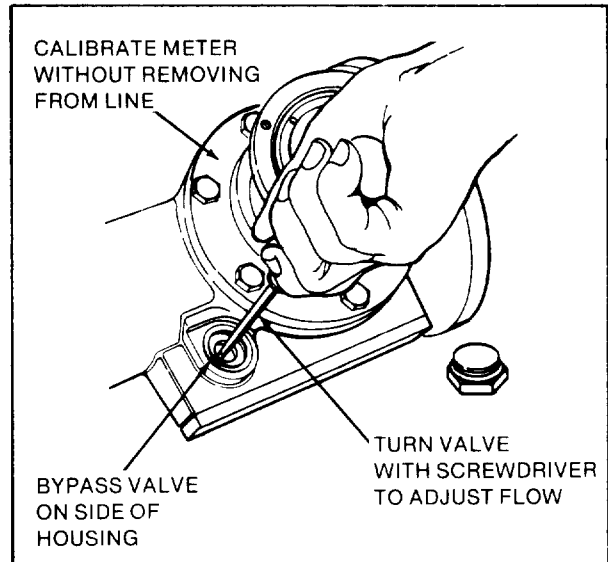

**Figure 4-2. Calibrating 2" and 3" Turbo Meters**

1. Remove the bypass cover nut with a wrench.
2. Using a wide-bladed screwdriver, loosen the bypass valve lock ring.
3. Adjust the bypass valve with a screwdriver in the following manner (See Figure 4-2):
  - a. To INCREASE registration, turn the slot in the valve perpendicular to the axis of the meter (line of flow). This will restrict the amount of volume flowing through the bypass and increase flow through the metering chamber.
  - b. To DECREASE registration, turn the slot in the valve parallel to the axis of the meter. This will increase liquid volume through the bypass and decrease flow through the metering chamber.

**NOTE**

The total range of the bypass adjustment occurs within a 90 degree or quarter turn of the valve from the parallel, inline position to the perpendicular position, or vice versa. The total range of adjustment is about four percent. Tested and calibrated at the factory, the bypass valve will be set at about 45° from the full "open" or "closed" position. This setting will allow for a ±2% adjustment to recalibrate the meter in the field.

4. With the valve turned to the desired bypass setting, tighten the valve lock ring.
5. Install and tighten the bypass valve cover nut.
6. Retest the meter to confirm the accuracy of the bypass adjustment. If the meter is still out of calibration, repeat the procedure outlined above.

#### 4-6. REGISTER BASE REPLACEMENT

Badger turbo meters can be serviced without removing the meters from the system. A typical service (See Figure 2-1) is equipped with drain and piping valves. To inspect or replace component parts of the head assembly, close the upstream and downstream valves. If the installation is equipped with an inlet and drain valve for flushing the meter, open the drain valve to relieve pressure from within the meter. However, if the meter piping is not equipped with a drain valve, proceed as follows to relieve pressure within the meter:

1. Do not remove the register base from the operating head assembly. The entire head assembly must be removed as a complete unit (See Figure 4-3).
2. Loosen each of the head bolts about one and one-half turns. Do not remove the bolts completely.

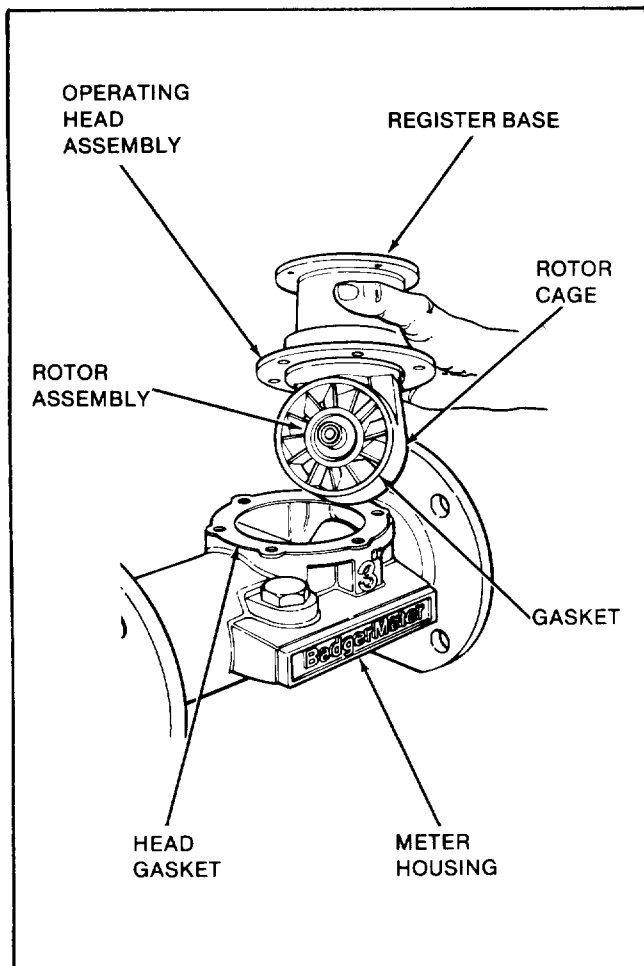

**Figure 4-3. Turbo Meters Serviced Without Removal from the Line**

3. If the gasket-seal between the meter head and the housing is not leaking at this time, pry the head assembly loose with a screwdriver. To accomplish this, insert the screwdriver from the outlet side of the head assembly where the head and housing join together.

#### CAUTION

Exercise precaution to make certain that fluid does not spray from the meter. The liquid spray could contact electrical equipment and create an electrical hazard.

4. Allow the meter to drain and relieve internal pressure.
5. When pressure is relieved, remove the head bolts and shift the head assembly toward the outlet-end of the meter to release the head-to-housing seal. Then lift the entire head assembly from the housing and, at the same time, tilt the operating head up to prevent the rotor from falling off the rotor spindle.

#### NOTE

Rotors made of Kynar or Ryton are furnished with two-pole and four-pole magnets depending on the type of application. Rotors with four-pole magnets are used with Badger's EPT-2 transmitter and EPU processor (electronic transmission system).

6. When the operating head has been removed, lift the rotor out of the rotor cage and set it aside. Remove the head gasket.

#### NOTE

A dummy cover plate is available to close the meter in the line and continue service while the operating head assembly is being inspected or parts are being replaced.

7. To remove the register base from the head assembly, loosen the seal screw on the base with a screwdriver. Rotate the base 45 degrees in either direction to release it from the bayonet lock detents on the head assembly.
8. The register base retaining ring is accessible through the rotor cage in the head assembly. With a Truarc right-angle pliers #1549, expand and remove the register retaining ring on the extension tube. When this is accomplished, the register base can be removed from the head assembly.
9. To reinstall or replace the register base, repeat the procedure above in reverse making sure that the retaining ring has been reinstalled on the extension tube.

**NOTE**

The head unit has a gasket bonded to the periphery of the rotor cage. Depending on the chemical solution to be metered, the gasket will be made of EPR, Buna N or Viton A material. Reinserting the head assembly into the meter housing correctly will require compressing the gasket slightly. This is done by tilting the top of the register base on the head toward the inlet side of the meter. The meter head has a pilot diameter machined into the cage at the gasket face. This pilot diameter must extend through the housing gasket inner diameter and into the housing bore. After lowering the head assembly into the housing, move the entire head assembly straight toward the inlet side of the meter. The pilot diameter must snap into the bore of the housing to provide a tight seal.

10. With the head gasket aligned and the head assembly properly positioned in the housing, reinstall and tighten the head bolts (between 90-180 in.-lbs. of torque).
11. Close the flushing system drain valve. Open the upstream valve partially, then open the downstream valve slightly which will purge any air from the service line. Then open both valves completely.

**4-7. SERVICING**

For periodic inspection or when operation of the turbo meter indicates a need for servicing, refer to the following paragraphs for instructions covering the removal, inspection and installation of service parts and assemblies. Refer to the illustrated parts list in Section V of this manual for part numbers of replaceable components and the correct ordering information. Any service or repair procedures that apply to a meter-mounted or free-standing accessory are provided in the IOM instruction manual pertaining to that device (also provided as a supplement to this manual.) If satisfactory repair cannot be made, contact the Industrial Products Division of Badger Meter, Inc.

**a. CHANGE GEAR REPLACEMENT**

1. Replacing the change gear on the register base spindle requires no gage to properly mesh this gear with the register change gear. A shoulder-stop is built into the spindle at the proper gear height thus eliminating gear adjustment.
2. The change gear in the register should be installed with the aid of a Badger change gear mesh gage (P/N 21747) to ensure proper gear mesh. The procedure is as follows:

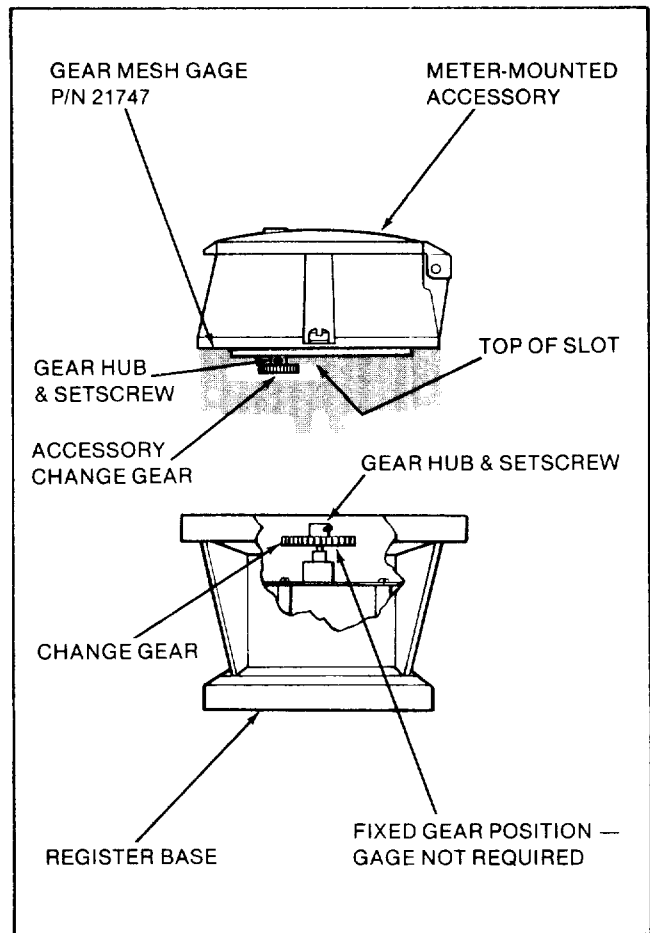

**Figure 4-4. Replacing Turbo Meter Change Gears Register Base and Register (or Accessory)**

- (a) Place the bottom of the register on the top edge of the gage (See Figure 4-4).
- (b) Adjust the change gear on the register spindle so that it rests against the "top" of the slot in the gage. Holding the change gear in this position, tighten the setscrew in the hub of the change gear.

**NOTE**

Install the change gears on the spindles with the hub of the gears in the "UP" position.

- (c) Carefully install the register on the base making sure that the gears fully mesh. Install and tighten the register seal screws.

**CAUTION**

Take care not to bend the spindles when installing the gears or reassembling the register to the register base.

## SECTION V ILLUSTRATED PARTS LIST

### 5-1. PARTS LOCATION ILLUSTRATION

The location and identification of assemblies and parts comprising the 2", 3", 4" and 6" turbo meters are shown on the exploded view illustration. Each assembly or part shown is identified by an index number that is cross-referenced to an associated parts list.

### 5-2. PARTS LIST

The parts list consists of the service assemblies and parts that are shown in the exploded illustration. The list provides the following information:

- a. ITEM NUMBER
- b. NAME OF PART
- c. PART NUMBER

### 5-3. ORDERING INFORMATION

Order replaceable parts through your local Badger Meter sales representative or directly from Industrial Sales Section of the Flow Products Division, Badger Meter, Inc. When placing an order, provide the following information:

- a. Specify the turbo meter size.
- b. Specify the type of meter housing material (for compatibility with fluid).
- c. Type of meter-mounted accessory:
  - (1) With register, specify the model of register and unit of measure plus the dial capacity.
  - (2) With pulse transmitter, specify the model of unit and pulse/unit of measure.
  - (3) With free-standing accessory such as a remote batch controller, specify the model and the number of stages. If an EPU processor, specify the options desired.
- d. Complete description of the assembly or parts required.
- e. Part number of the item as indicated in the parts list.
- f. Quantity of parts required.
- g. A purchase order number plus exact return and billing address.



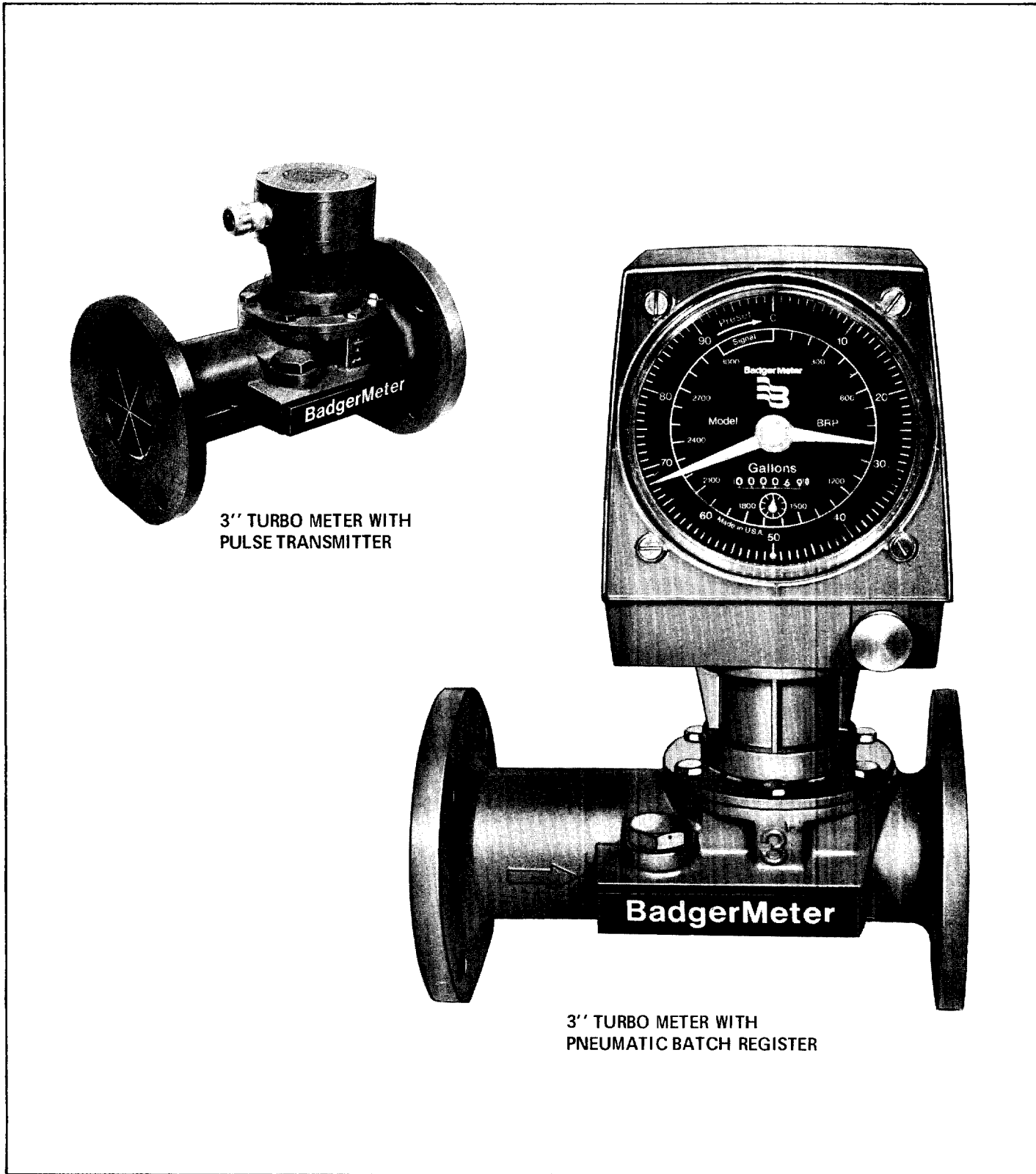

Figure 4.5. Typical Badger Turbo Meter/Accessory Combinations

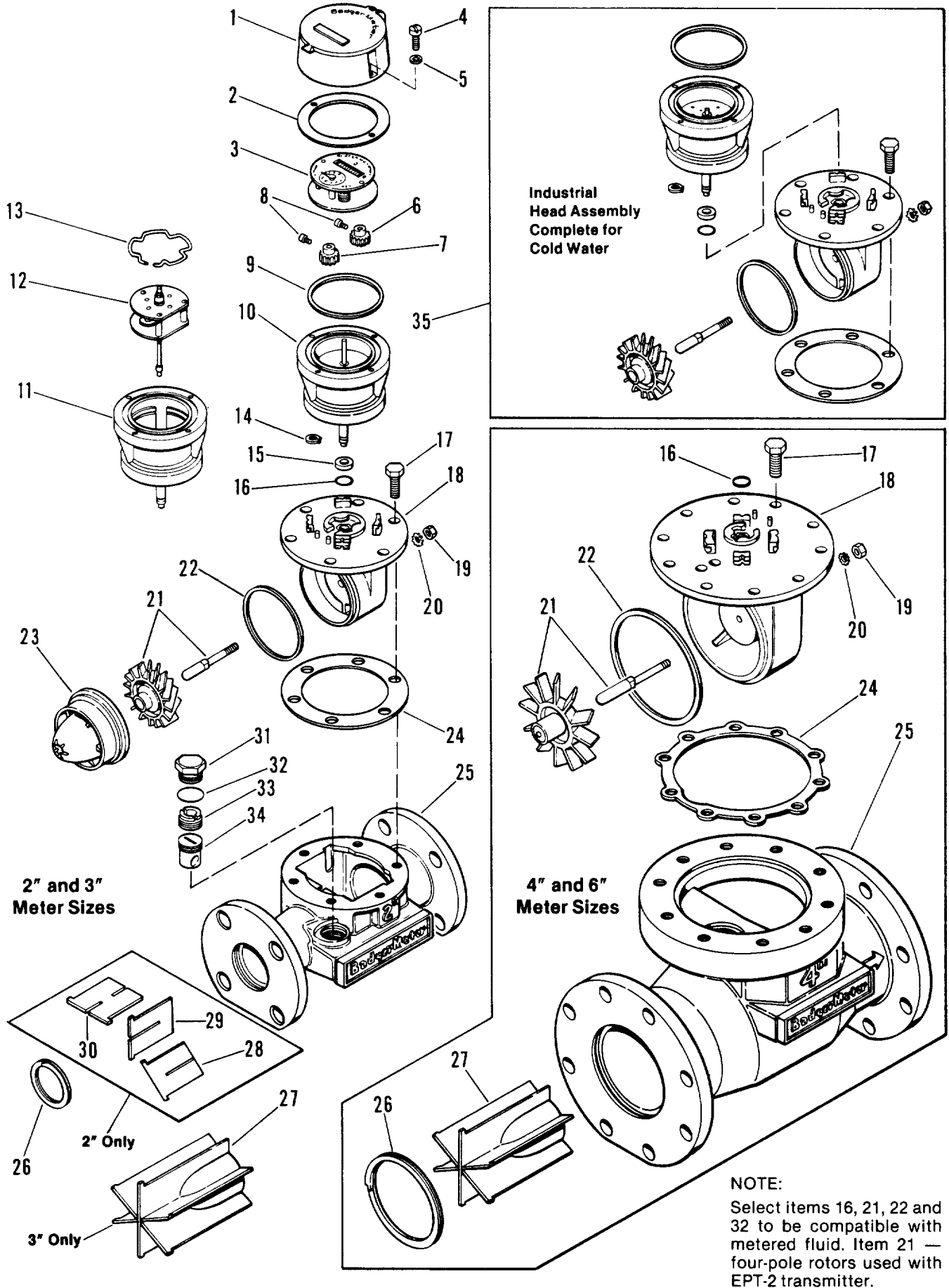

Figure 5-1. 2", 3", 4" and 6" Turbo Meters

## PARTS LIST

ITEM NO.	NAME OF PART	2" PART NUMBER	3" PART NUMBER	4" PART NUMBER	6" PART NUMBER
1	Hood Assembly, Register .....	58234-00200	58234-00200	58234-00200	58234-00200
2	Gasket, Register Cover .....	58404-00100	58404-00100	58404-00100	58404-00100
3	Register Assy., Specify Meter Size & Registration Req'd. ...	21228-00000	21228-00000	21228-00000	21228-00000
4	Screw, Cover to Register Base .....	55046-25100	55046-25100	55046-25100	55046-25100
5	Lockwasher .....	55293-01000	55293-01000	55293-01000	55293-01000
6	Change Gear, Register (Specify no. of teeth and dia.) .....	.....	.....	.....	.....
7	Change Gear, Register Base (Spec. no. of teeth and dia.) ..	.....	.....	.....	.....
8	Setscrew, Change Gear .....	1065-00000	1065-00000	1065-00000	1065-00000
9	Tetraseal .....	22559-03400	22559-03400	22559-03400	22559-03400
10	Register Base Assembly, 366 $\frac{2}{3}$ :1 .....	56786-00100	56786-00100	56786-00200	56786-00300
10	Register Base Assembly, 1200:1 .....	56786-00400	56786-00400	56786-00500	56786-00600
11	Register Base, Only .....	56785-00100	56785-00100	56785-00200	56785-00300
12	Gear Train Assembly w/Magnet, 366 $\frac{2}{3}$ :1 .....	56782-00100	56782-00100	56782-00200	56782-00300
12	Gear Train Assembly w/Magnet, 1200:1 .....	56782-00400	56782-00400	56782-00500	56782-00600
13	Ring, Gear Train Assy. Retaining .....	1013-00000	1013-00000	1013-00000	1013-00000
14	Retaining Ring, Register Base (316 S.S.) .....	22886-01200	22886-01200	22886-01200	22886-01200
*14	Retaining Ring, Register Base (Bronze) .....	22886-01300	22886-01300	22886-01300	22886-01300
*15	Spacer, Register Base .....	57337-00100	57337-00100	57337-00100	57337-00100
*16	"O" Ring, Register Base, Buna N .....	55300-11000	55300-11000	55300-11000	55300-11000
*16	"O" Ring, Register Base, EPR .....	31132-04600	31132-04600	31132-04600	31132-04600
*16	"O" Ring, Register Base, Viton A .....	31132-04500	31132-04500	31132-04500	31132-04500
17	Bolt, Hex. Head .....	55030-16600	55030-16600	55031-11600	55031-11600
18	Head Only .....	57312-00100	57312-00100	57282-00100	57287-00100
19	Nut, Hex., Rotor Spindle .....	55006-03500	55006-03500	55007-02800	55007-02800
20	Lockwasher, Rotor Spindle .....	55274-00800	55274-00800	55274-01100	55274-01100
21	Rotor & Spindle, Kynar, 2-Pole (Buna N Seal) .....	56998-00500	56998-00600	56998-00700	56998-00800
21	Rotor & Spindle, Kynar, 2-Pole (EPR Seal) .....	56998-01300	56998-01400	56998-01500	56998-01600
21	Rotor & Spindle, Kynar, 2-Pole (Viton Seal) .....	56998-00900	56998-01000	56998-01100	56998-01200
21	Rotor & Spindle, Rytan, 2-Pole (Buna N Seal) .....	56998-03400	56998-03500	56998-03600	56998-03700
21	Rotor & Spindle, Kynar, 4-Pole (Buna N Seal) .....	56998-02000	56998-02100	56998-02200	56998-02300
21	Rotor & Spindle, Kynar, 4-Pole (EPR Seal) .....	56998-02800	56998-02900	56998-03000	56998-03100
21	Rotor & Spindle, Kynar, 4-Pole (Viton Seal) .....	56998-02400	56998-02500	56998-02600	56998-02700
21	Rotor & Spindle, Rytan, 4-Pole (Buna N Seal) .....	56998-04600	56998-04700	56998-04800	56998-04900
*22	Tetraseal, Head, Buna N .....	22559-04300	22559-04300	22559-04400	22559-04500
*22	Tetraseal, Head, EPR .....	22559-04700	22559-04700	22559-04800	22559-04900
*22	Tetraseal, Head, Viton A .....	22559-05000	22559-05000	22559-05100	22559-05200
23	Nose Cone .....	57341-00300	.....	.....	.....
*24	Gasket, Head, Asbestos/Spec. Binder (Viton Seal only) ...	34899-00200	34899-00200	56331-00200	56327-00200
*24	Gasket, Head, Nonasbestos for Buna N Seal only .....	34899-00300	34899-00300	56331-00300	56327-00300
*24	Gasket, Head, Nonasbestos for EPR Seal only .....	34899-00400	34899-00400	56331-00400	56327-00400
25	Housing, Bronze, 150# Flange .....	56079-00100	34841-00100	57280-00100	57288-00100
25	Housing, Bronze, 300# Flange .....	56079-00200	34841-00200	57280-00200	57288-00200
25	Housing, Cast Iron, 125# Flange .....	56079-00400	34841-00300	57280-00300	57288-00300
25	Housing, Cast Iron, 250# Flange .....	56079-00500	34841-00400	57280-00400	57288-00400
25	Housing, Cast Steel, 150# Flange .....	57640-00100	34841-00500	57280-00900	57288-00900
25	Housing, Cast Steel, 300# Flange .....	57640-00200	34841-00600	57280-01000	57288-01000
25	Housing, 316 Stainless, 150# Flange .....	57640-00300	34841-00700	57280-01100	57288-01100
25	Housing, 316 Stainless, 300# Flange .....	57640-00400	34841-00800	57280-01200	57288-01200
26	Retaining Ring, Straightening Vane .....	34900-00200	34900-00100	34900-00300	34900-00400
27	Straightening Vane Assembly, Complete .....	.....	34880-00200	56340-00300	56340-00400
28	Straightening Vane .....	56082-00100	.....	.....	.....
29	Straightening Vane .....	56083-00100	.....	.....	.....
30	Straightening Vane .....	56084-00100	.....	.....	.....
31	Cover Nut, Bypass Valve .....	34870-00200	34870-00200	.....	.....
*32	"O" Ring, Bypass Valve, Buna N .....	55300-02200	55300-02200	.....	.....
*32	"O" Ring, Bypass Valve, EPR .....	31132-04300	31132-04300	.....	.....
*32	"O" Ring, Bypass Valve, Viton A .....	31132-04400	31132-04400	.....	.....
33	Lock Ring, Bypass Valve .....	34897-00200	34897-00200	.....	.....
34	Valve, Bypass .....	34869-00200	34869-00200	.....	.....
	Dummy Cover (Not Shown) .....	56813-00100	56813-00100	56814-00100	56815-00100
	Gasket, Dummy Cover (Not Shown) .....	57646-00100	57646-00100	57647-00100	57648-00100
35	Industrial Head Assembly, Complete, Specify Fluid .....	57381-00000	57381-00000	57381-00000	57381-00000

Service Note: For 2" and 3" turbo meters, "shims" are provided with the rotor spindle. It is important to reinstall shims when servicing rotor and spindle assembly.

\*Recommended spare parts.

Rotors with 4-pole magnets used only with EPT-2 transmitters.

NOTE: When ordering parts, give part numbers, name of parts model and size of meter. For prices, refer to Repair Parts Price List PPL-903.

## WARRANTY

Badger warrants meters and parts manufactured by it and supplied hereunder to be free from defects in materials and workmanship for a period of 18 months from date of shipment or 12 months from date of installation, whichever period shall be shorter. If within such period any meters or parts shall be proved to Seller's satisfaction to be defective, such meters or parts shall be repaired or replaced at Seller's option. Seller's obligation hereunder shall be limited to such repair and replacement and shall be conditioned upon Seller's receiving written notice of any alleged defect within 10 days after its discovery and, at Seller's option, return of such meters or parts to Seller f.o.b. its factory. THE FOREGOING WARRANTY IS EXCLUSIVE AND IN LIEU OF ALL OTHER EXPRESS OR IMPLIED WARRANTIES WHATSOEVER INCLUDING BUT NOT LIMITED TO IMPLIED WARRANTIES (EXCEPT OF TITLE) OF MERCHANTABILITY AND FITNESS FOR A PARTICULAR PURPOSE. Badger shall not be liable for any defects attributable to acts or omissions of others after shipment, nor any consequential, incidental or contingent damage whatsoever.

## NUCLEAR DISCLAIMER

Equipment sold by Badger Meter, Inc. is not intended for use in connection with any nuclear facility or activity unless covered by a specific quotation where the conditions of such usage will be detailed. If equipment is used in a nuclear facility or activity without a supporting quotation, Badger Meter disclaims all liability for any damage, injury or contamination, and the buyer shall indemnify and hold Badger Meter, its officers, agents, employees, successors, assigns and customers, whether direct or indirect, harmless from and against any and all losses, damages or expenses of whatever form or nature (including attorneys' fees and other costs of defending any action) which they, or any of them, may sustain or incur, whether as a result of breach of contract, warranty, tort (including negligence), strict liability or other theories of law, by reason of such use.

# BADGER SERIES 76 METER REGISTERS

*For Water Conditioning*

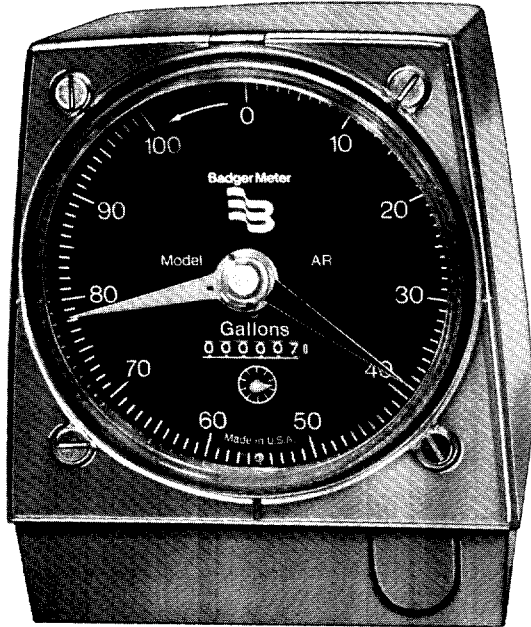

**MODEL AR**  
**Automatic Reset Register**

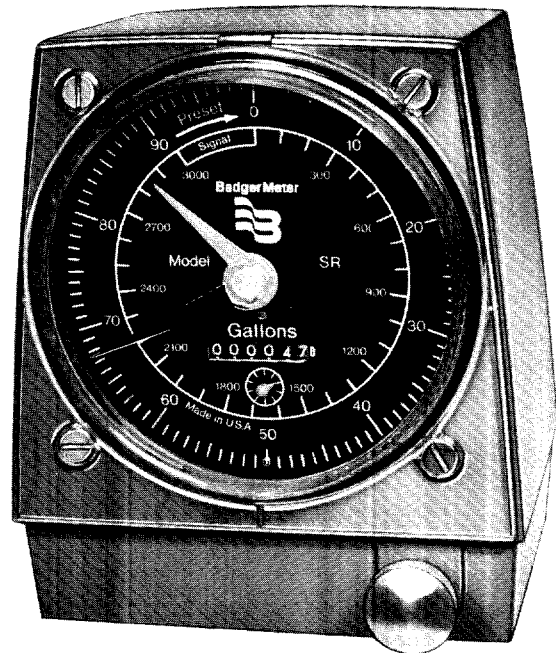

**MODEL SR**  
**Signal Register**

Register Models AR and SR are used to measure pre-determined quantities of liquid and then transmit a signal which activates other equipment. Their widest application is in water conditioning systems.

The principal difference between the two registers is that Model AR resets itself automatically for each water conditioning cycle, whereas the SR is reset with a register knob.

The AR register is equipped with a nickel-plated reset pointer and a red sweep pointer which moves counter-clockwise from the preset position. When the red pointer reaches zero, a trip cam closes a signal switch and a motor switch. The signal is used to start tank regeneration, while the motor resets the pointers at their original position.

With the SR register, the red pointer is used to preset small quantities and the nickel pointer for larger amounts. When both pointers reach zero, a double-throw switch is actuated. This switch can be connected to an electrical circuit to operate a warning bell or alarm, a pump, valve or other equipment.

Models AR and SR are part of the Series 76 line of interchangeable meter registers for use on Badger's industrial-type meters. Three other Series 76 registers, used primarily for liquid batching, are described in Bulletin IBR-3010.

## AR AND SR REGISTER SPECIFICATIONS

### PHYSICAL

Housing: Glass-filled polycarbonate— NEMA 4  
Internal Plates: Brass  
Gears: Brass or Thermoplastic  
Shafts: 303 Stainless Steel  
Register Size: 7 1/2" width, 8 7/8" height, 6 3/4" depth  
Dial Size: 5 3/4"  
Totalizer: Six-digit, non-reset

### ELECTRICAL

Contact Rating: 7 amps at 115 VAC  
AR register available for 24 VAC, 115 VAC, and 230 VAC



**Badger Meter, Inc.** Industrial Products Division  
4545 West Brown Deer Road, Milwaukee, Wisconsin 53223

## OPERATION OF AR REGISTER

The register is preset by loosening two screws in the pointer hub and moving the pointers to the desired position. This setting is then "locked in" by retightening the hub screws. (For detailed instructions, see Installation Manual IOM-024.)

As liquid is metered, the red sweep pointer moves counterclockwise. At the zero reading, a cam on the pointer shaft closes the signal and reset motor switches.

The reset motor drives the nickel-plated reset pointer counterclockwise until it also reaches zero. The nickel

pointer "picks up" the red pointer and carries it back to the original preset position.

The motor switch opens, the motor stops, and the signal to external equipment is terminated. The register is now ready for the next metering cycle.

For installations with more than one water conditioning tank, the AR can be supplied with a built-in relay which can be wired into the control circuit in accordance with the recommendations of the water conditioner manufacturer.

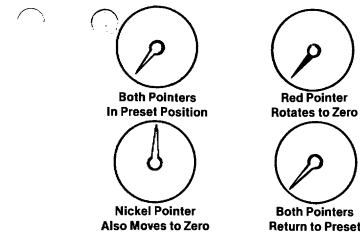

## OPERATION OF SR REGISTER

To preset Model SR, push in the knob on the front of the register and turn it counterclockwise until the pointers reach the desired setting. The nickel-plated inner pointer will move one graduation for each complete revolution of the red outer pointer.

Release the knob and the register will be ready for the metering cycle.

As liquid is metered, the pointers will rotate toward zero. When they reach zero position, a built-in cam closes the signal switch. In a typical installation, the signal is used to operate an alarm or light so the operator knows that a tank needs regeneration.

When regeneration is completed, the operator resets the register to the desired quantity.

DIAL CAPACITIES FOR AR AND SR REGISTERS												
AR REGISTERS	5/8" Disc	3/4" Disc	1" Disc	1 1/2" Disc	2" Disc	2" Turbine	3" Turbine	4" Turbine	2" Turbo	3" Turbo	4" Turbo	6" Turbo
100	x	x	x									
200	x	x	x									
500	x	x	x									
1,000	x	x	x	x								
2,000	x	x	x	x	x							
5,000	x	x	x	x	x	x						
10,000	x	x	x	x	x	x	x					
20,000	x	x	x	x	x	x	x	x				
50,000	x	x	x	x	x	x	x	x	x			
100,000	x	x	x	x	x	x	x	x	x	x		
200,000	x	x	x	x	x	x	x	x	x	x	x	
500,000	x	x	x	x	x	x	x	x	x	x	x	x
1,000,000	x	x	x	x	x	x	x	x	x	x	x	x
2,000,000												
5,000,000												
10,000,000												

Basic AR register dials in gallons. Metric dials in litres up to 50,000. Dials 100,000 and above are in equivalent M<sup>3</sup>.

SR REGISTERS													
Inner Pointer	Outer Pointer	5/8" Disc	3/4" Disc	1" Disc	1 1/2" Disc	2" Disc	2" Turbine	3" Turbine	4" Turbine	2" Turbo	3" Turbo	4" Turbo	6" Turbo
3,000	100	x	x	x	x	x	x	x	x	x	x	x	x
30,000	1,000	x	x	x	x	x	x	x	x	x	x	x	x
300,000	10,000	x	x	x	x	x	x	x	x	x	x	x	x
3,000,000	100,000												

Basic SR dials in gallons. Metric dials in litres up to 30,000. Dials 300,000 and above are in equivalent M<sup>3</sup>.

DIMENSIONS (in Inches)												
	12-1/4	14	16	18-3/8	22-7/8	15-1/4	24	24	10	12	14	18
A	12-1/4	14	16	18-3/8	22-7/8	15-1/4	24	24	10	12	14	18
B	7-1/2	9	10-3/4	12-5/8	15-1/4	15-1/4	24	24	10	12	14	18
C	15-1/16	15-7/16	16-7/8	18-7/16	20-1/16	28-15/16	35-1/2	35-7/8	16-7/8	17-1/8	20-1/16	22-1/2
D	1-3/8	1-3/4	2-1/4	2-5/8	3-7/16	8-1/16	12-3/4	13-5/16	2-3/4	3-1/2	4-1/4	5-1/4
Max. Depth	6-1/2	6-3/4	7-1/8	9-1/2	12-9/16	8-1/8	12-1/2	12-3/4	6-13/16	7-1/2	9	11

● Add 2-1/2" when using cooling adapter. Allow additional 7-1/4" clearance for removing register housing.

## MODEL AR WIRING DIAGRAMS

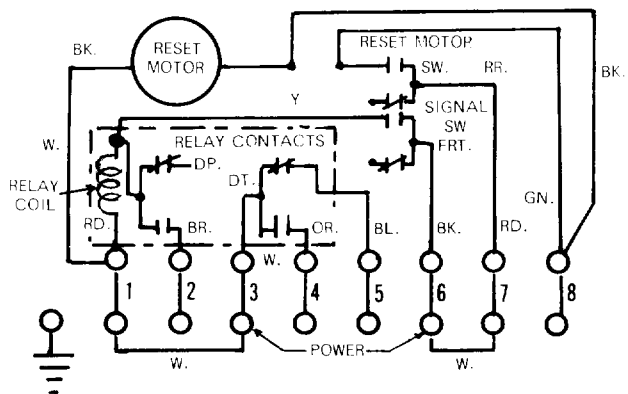

**AR With Relay**

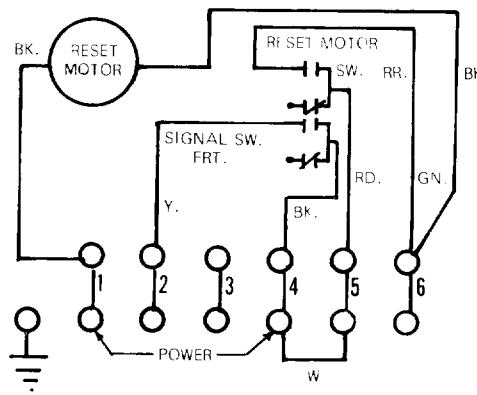

**AR Less Relay**

## MODEL SR WIRING DIAGRAM

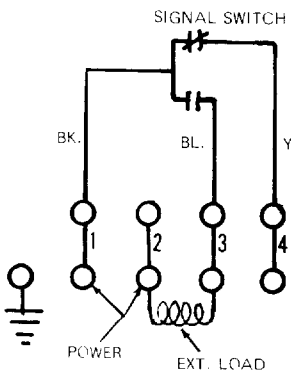

### WARRANTY

Badger warrants meters and parts manufactured by it and supplied hereunder to be free from defects in materials and workmanship for a period of 18 months from date of shipment or 12 months from date of installation, whichever period shall be shorter. If within such period any meters or parts shall be proved to Seller's satisfaction to be defective, such meters or parts shall be repaired or replaced at Seller's option. Seller's obligation hereunder shall be limited to such repair and replacement and shall be conditioned upon Seller's receiving written notice of any alleged defect within 10 days after

its discovery and, at Seller's option, return of such meters or parts to Seller f.o.b. its factory. THE FOREGOING WARRANTY IS EXCLUSIVE AND IN LIEU OF ALL OTHER EXPRESS OR IMPLIED WARRANTIES WHATSOEVER INCLUDING BUT NOT LIMITED TO IMPLIED WARRANTIES (EXCEPT OF TITLE) OF MERCHANTABILITY AND FITNESS FOR A PARTICULAR PURPOSE. Badger shall not be liable for any defects attributable to acts or omissions of others after shipment, nor any consequential, incidental or contingent damage whatsoever.

# INSTALLATION OPERATION AND MAINTENANCE MANUAL

**MODELS AR AND SR  
METER REGISTERS**

**Badger Meter, Inc.** Industrial Products Division  
4545 West Brown Deer Road, Milwaukee, Wisconsin 53223





**SCOPE OF THE MANUAL**

This manual provides information pertaining to the installation, operation and maintenance of Badger Series 76, Models AR and SR Meter Registers. Before attempting installation, operation or maintenance, read the instructions presented to become familiar with the procedures involved. Retain the manual in a readily accessible location for future reference.

**CHANGES IN THE MANUAL**

Changes or additions to the manual are covered by a "CHANGE NOTICE" form that is supplied with the manual when applicable. The "CHANGE NOTICE" will explain any differences between the register received and the registers covered in this manual.

**Table 1-1. Technical Specifications**

DRIVE .....	Mechanical 2-pin direct coupling (Adapter must be used for magnetic drive meters)
MOUNTING .....	4 holes equidistant on 3.665 in. diameter circle
DIMENSIONS	
Height .....	8-7/8 in.
Width .....	7-1/2 in.
Depth .....	7-1/2 in. SR 6-3/4 in. AR
WEIGHT .....	8 lbs.
OPERATING TEMPERATURE .....	250°F, with proper adapter
DIAL	
Diameter .....	5-3/4 in.
Display .....	White on black
TOTALIZER COUNTER	
Type .....	Non-resettable
Display .....	Six-digit (to 999,999)
Numerals .....	5/32 in. high — white on black
TEST CIRCLE .....	10 increments each equal to 1/10 of last totalizer digit
ENCLOSURE	
Type .....	Moistureproof and dustproof
Housing and base .....	NEMA-4, foam molded polycarbonate, glass filled
Bezel .....	Clear polycarbonate
MODEL AR — AUTOMATIC REGISTER	
Accuracy and repeatability .....	Signal within $\pm 2\%$ of dial capacity
Pointers .....	Two, nickel-plated outer reset and red inner reading
Switch and relay contact rating .....	7 amps, 125-250 vac
Motor and relay (one of the ratings listed) .....	24 vac, 60 Hz, 20 rph 110 vac, 60 Hz, 20 rph 110 vac, 60 Hz, 4 rph 220 vac, 50 Hz, 20 rph
MODEL SR — SIGNAL REGISTER	
Accuracy and repeatability .....	Signal within $\pm 1\%$ of outer circle
Pointers .....	Two, nickel-plated inner and red outer
Contact rating .....	7 amps, 110 or 220 vac, 1/8 hp at 110 vac, 1/4 hp at 220 vac, 1/2 amp at 125 vdc, 1/4 amp at 250 vdc

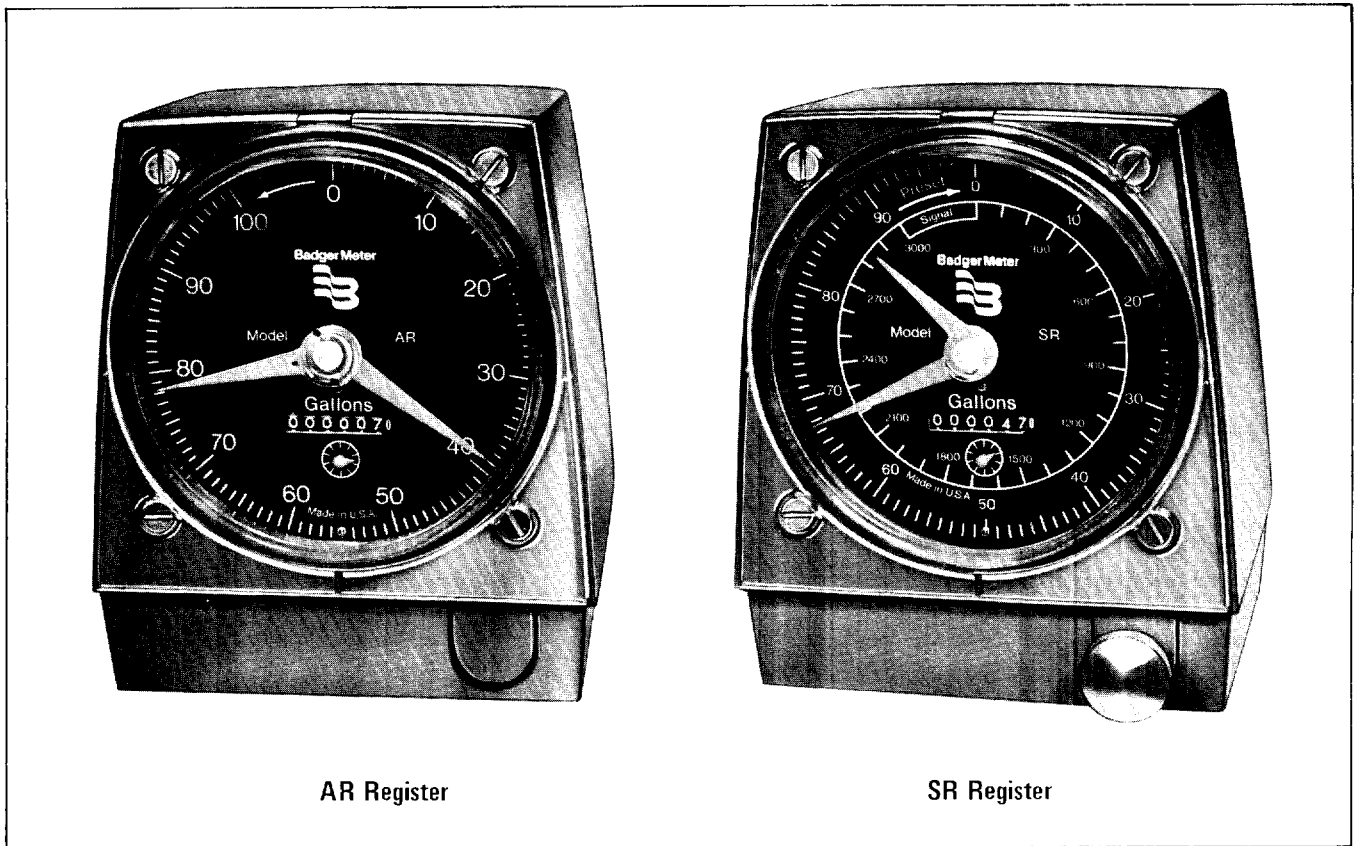

Figure 1-1.

## Section I GENERAL INFORMATION

### 1-1. GENERAL DESCRIPTION

The Badger Model AR Automatic Reset Register and Model SR Signal Register are designed primarily to control the regeneration cycle of water softeners. (See Figure 1-1.) Models AR and SR employ electrical switching to provide the signal for external control, and both are equipped with a 6-digit non-reset totalizer. The basic configuration and mounting of the instruments is the same. The registers are available in a wide range of dial capacities and units of measurement.

The Model AR is an automatic reset unit for repetition of the same preset metered cycle. The instrument may be preset to any quantity within the dial capacity by positioning the nickel-plated outer reset pointer. The housing must be removed to preset. The red pointer indicates the amount of liquid remaining to be delivered. At the end of a cycle when the red delivery pointer reaches zero, the motor-driven reset pointer is turned one complete revolution to return the red pointer to the preset point in readiness for the next cycle. End of cycle and reset switching are cam actuated. The AR can be automatically reset any time prior to the completion of the cycle by an external momentary contact.

The Model SR is a manual preset register with two pointers. The pointers are preset with the control knob on

the front of the unit. When both pointers reach zero, the internal cam-actuated microswitch closes to provide the control signal.

External electrical connections are made to the rear of the instrument. The housings are easily removed for internal access required for wiring, gear changes, settings and adjustments.

### 1-2. INSTRUMENT CONFIGURATIONS

The Model AR is available with an internal relay for use in multiple register systems. The relay may be connected into the control circuit to lock out one register reset motor until a second register regeneration cycle is completed.

### 1-3. APPLICATIONS

The Model AR and SR Registers are well suited for control of industrial water softener installations, whether single manual regeneration or multiple automatic regeneration. All Series 76 registers can be used interchangeably on Badger disc, oscillating piston, turbine, turbo and propeller meters, both mechanical and magnetic drive. These registers are ideal replacements for older similar registers.

## Section II

### INSTALLATION

#### 2-1. UNPACKING AND INSPECTION

The Model Series 76 Registers are shipped to the customer in a special shipping container to avoid damage during transit. Upon receipt of the instrument, perform the following unpacking and inspection procedures:

##### NOTE

If damage to the shipping container is evident upon receipt of the instrument, request a representative of the carrier to be present when the instrument is unpacked.

a. Carefully open the shipping container, following any instructions that may be marked on the container. Remove all cushioning material surrounding the instrument and carefully lift the instrument from the container. Retain the container and all cushioning material for possible use in storage or reshipment.

b. Check the contents of the shipping container against the packing list to verify that all equipment has been received.

c. Visually inspect the instrument for physical damage such as dents, scratches, loose or broken parts or any other signs of physical damage that may have occurred during shipment.

##### NOTE

If damage is found, request an inspection by the carrier's agent within 48 hours of delivery. Then file a claim with the carrier. A claim for equipment damaged in transit is the responsibility of the customer.

#### 2-2. INSTALLING THE REGISTER

##### NOTE

Installation of the register in areas of high temperature or severe vibration should be avoided. When used on oscillating piston meters, turbine meters and SOT meters with flow temperatures over 140°F, use finned mounting adapter to dissipate heat. Use P/N 31278-1 for oscillating piston meters and P/N 31728 for SOT and turbine meters.

a. **MOUNTING THE REGISTER.** (See Figure 2-1.) The register mount will fit a 3/4 inch hood base. The instrument is mounted with four or two 1/4-20 screws. The mounting holes on existing meters may have to be drilled to 17/64 inch dia. to accept the 1/4 inch screws.

1. Remove the existing register if meter is so equipped.

2. Check the mounting holes on meter. Re-drill to 17/64 inch to accept 1/4 inch screws if necessary.

3. Check the position and alignment of pin drive coupling. Surface A must be 3/32" to 1/8" below Surface B (See Figure 2-1). Be sure to tighten the set screw after adjustment.

4. Place the square section gasket in the mounting set.

5. Align the drive holes in the base of register with the drive coupling pins as closely as possible. Carefully position the register on the meter mount or magnetic drive adapter so the drive pins engage. Rotate the register to align the mounting holes and position the register as desired.

6. Install 1/4-20 mounting screws to secure the register.

b. **ELECTRICAL CONNECTIONS.** All electrical (power and signal) connections to a register are made to a terminal strip located inside the instrument enclosure. Remove the four housing cover screws in the base and lift off the cover to gain access. Caution must be exercised in cover removal to avoid bending the pointers. When the screws are removed, lift the cover in a slightly forward motion. It is recommended that flexible conduit be used for a distance of at least 2 feet from the register to allow access to the meter.

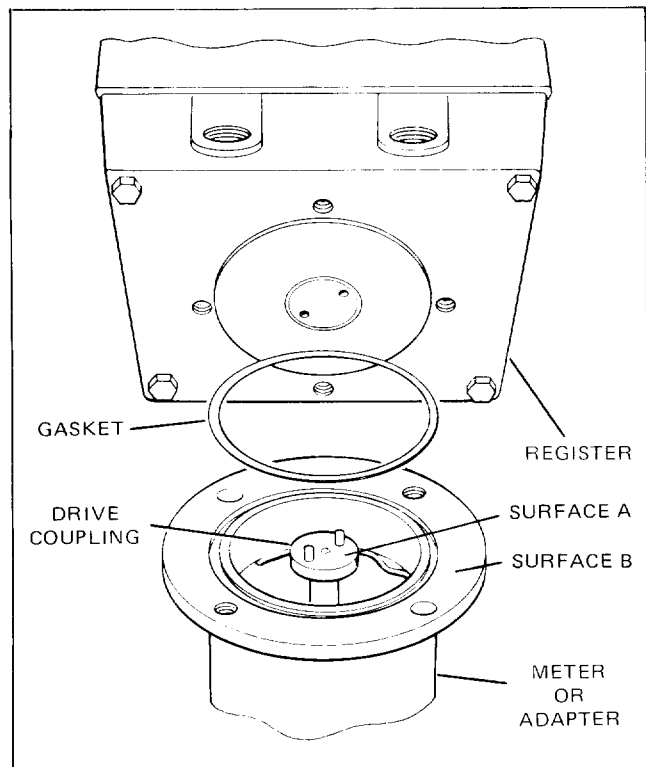

**Figure 2-1. Register Mounting**

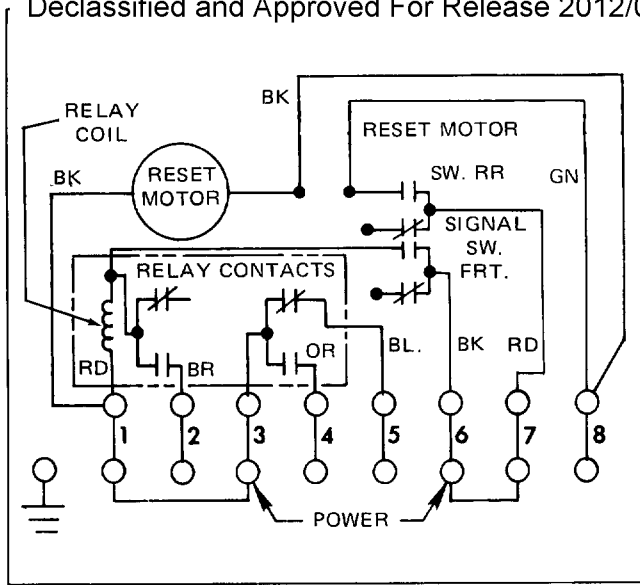

Figure 2-2. Internal Wiring Diagram — Model AR with Relay

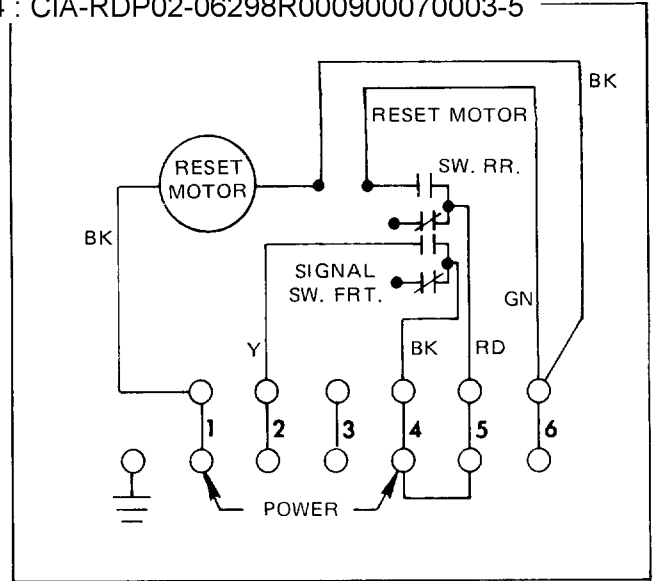

Figure 2-3. Internal Wiring Diagram — Model AR less Relay

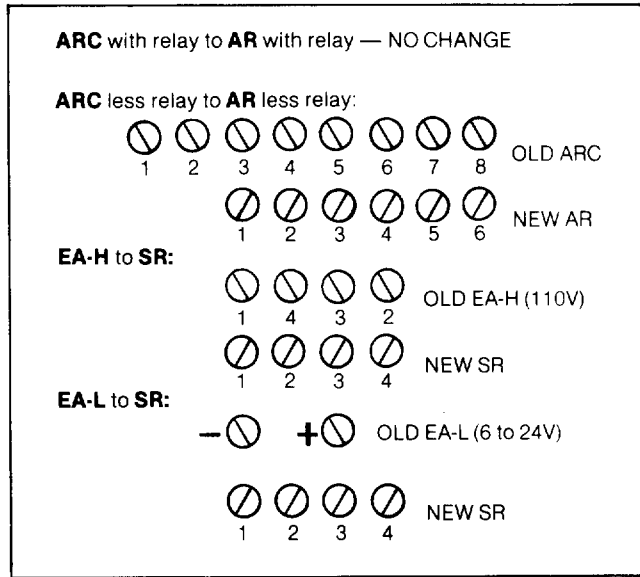

Figure 2-5. Wiring Changes for Register Replacement

The basic internal wiring diagrams are shown in Figures 2-2 thru 2-4. If additional information or assistance is required to make a specific installation, contact Badger Meter, Inc., Flow Products Division, Industrial Sales Department, or the local representative. Make sure that all wiring to the instrument (both power and signal) conforms with the local electrical code.

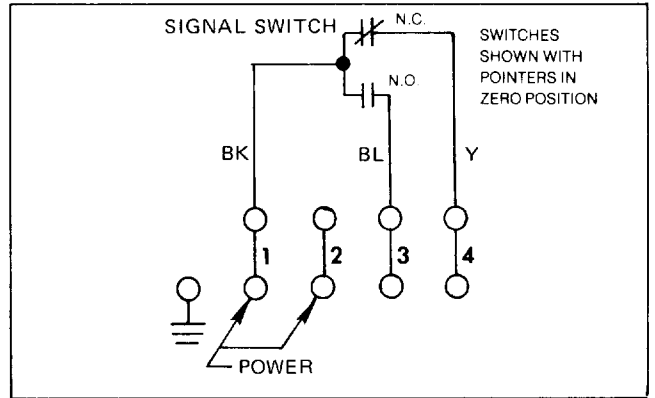

Figure 2-4. Internal Wiring Diagram — Model SR

**2-3. PERFORMANCE CHECK**

Although the registers are factory adjusted for switch actuation and pointer alignment, it is advisable to check the operation of a register before actual use. For AR registers the reset pointer is set at 50 per cent of the scale. The user may require a different operating point. Complete adjustment and test information is given in Section V.

**2-4. REGISTER REPLACEMENT**

Model AR and SR registers can be used to replace Model ARC, EA-H and EA-L registers. The necessary wiring changes are shown in Figure 2-5.

**Section III  
OPERATION**

**3-1. CONTROLS AND INDICATORS**

a. CONTROL KNOB. The single control knob for Register SR is used to preset the desired flow quantity as indicated by the pointers. Pushing the knob in and turning counterclockwise moves the pointers to the desired batch quantity. The inner pointer moves one graduation for each

complete revolution of the outer pointer.

b. DIALS. The 5-3/4 inch dial is calibrated in units of measure marked on the dial face. The small test circle is marked with 10 divisions. One revolution of the test circle pointer is equivalent to one digit change on the lowest (right side) position of the totalizer.

### 3-2. OPERATING PROCEDURE — SR REGISTER

At the end of a flow cycle the pointers will both be at zero. To preset the unit, proceed as follows:

- Push in the control knob which will engage the coupling on the preset shaft with the register gear train.
- Turn the knob counterclockwise to the desired quantity as indicated by the pointers. Release the knob. Spring tension will return the knob to the out position.
- The register will start when flow starts and continue to indicate the remaining quantity until the pointers reach zero at the end of the cycle. At this time the signal switch opens or closes to operate external alarms or functions. The pointers move counterclockwise during operation.
- After regeneration preset the register as described above.

### 3-3. OPERATING PROCEDURE — AR REGISTER

To preset the register, remove housing cover and proceed as follows:

- Rotate the reset pointer until it picks up the red pointer and continue until the switch arm drops into the notch in the motor cam.
- Loosen two screws in the reset pointer hub and position both pointers to the desired preset quantity. Be sure the motor cam remains stationary during pointer positioning.
- Tighten the reset pointer hub screws.
- Run the register through one cycle to check preset. The instrument must stop with both pointers at the preset position.

### 3-4. OPERATOR EMERGENCY MAINTENANCE

If the register does not start or stops prematurely, check the power source. If the power source checks out, the register may require adjustment. Refer to troubleshooting data and adjustment procedures in Section V.

If a register fails to stop at zero, turn off the power to the instrument. Investigate the cause of malfunction (Section V).

## Section IV

### PRINCIPLES OF OPERATION

#### 4-1. GENERAL

Whenever there is liquid flow, the movement of the meter's measuring element is coupled to the register and transferred to the indicating pointers and totalizer through a gear train. The exact makeup of the gear train is determined by the dial capacity, unit of measure and meter application. Each instrument incorporates a set of change gears which allows some variation in overall gear train ratio to compensate for differences in liquids and conditions.

In an automatic system the end of cycle or zero point signal is used to start the regeneration cycle. The switch is cam actuated off the pointer shaft(s). The actuation of the switch(es) and position of the pointer(s) are adjustable to permit exact correlation between the pointers and switch action.

#### 4-2. MODEL SR

A coupling is mounted on the control knob shaft. With the knob in, the coupling engages the gear train and allows the pointers to be moved when the knob is rotated.

Initially with the register at zero, the signal switch is on the low part of the pointer cams. In this position the signal switch (normally open contacts) is open. When the pointers are moved off zero to preset, the cams rotate so that the signal switch is on the high part of the cams and the signal switch (normally open contacts) is closed. When flow starts, the register continues to run toward zero until both pointer cams reach the initial position to reverse the switch mode.

#### 4-3. MODEL AR (See Figure 4-1)

The Model AR employs two tandem cams to actuate the signal switch and reset motor switch. The front signal cam is

mounted on the delivery (red) pointer shaft; the rear motor switch on the reset motor-pointer shaft. Both cams contact the common pivoting switch arm which actuates the switches. Each switch is mounted independently on adjustable brackets to allow separate adjustment. The switch arm is latched or unlatched by a spring-loaded pawl as controlled by the cams.

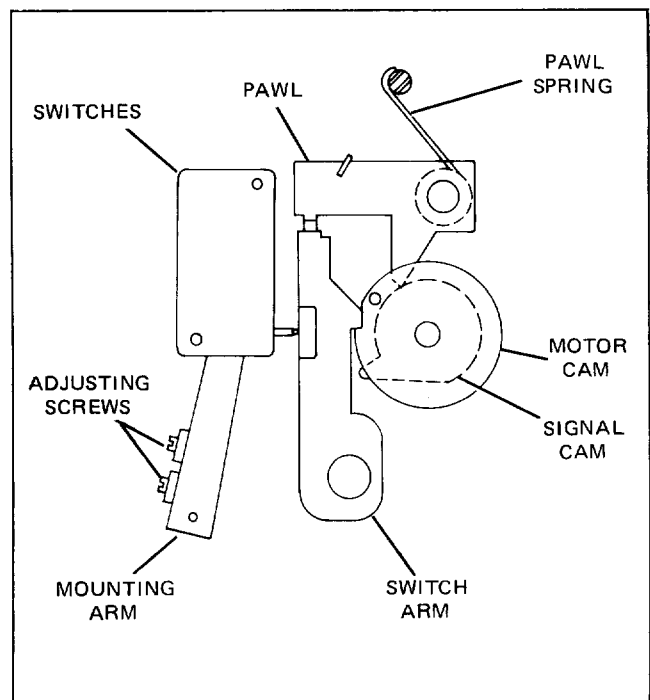

Figure 4-1. Model AR Switch Mechanism

At the end of the preset cycle, the switch arm is at rest in the notch or low point of the motor cam. Both the reset motor switch and signal switch are open. The pawl is contacting the outer edge of the switch arm as shown in Figure 4-1.

When flow starts, the red pointer and signal cam are driven around until the high point of the signal cam moves the switch arm to close the switches at zero. This allows the pawl to engage the notch in the switch arm to lock the switches in close position. The reset motor is energized through the motor switch and drives the reset pointer and reset motor cam. The signal switch closure is used to start the regeneration cycle either directly or through a relay and

external circuitry provided by the water conditioning equipment manufacturer.

The motor cam continues to rotate and the reset pointer picks up the red delivery pointer to return to the preset position. As the cam nears the end of its full revolution, the pin on the motor cam pushes the pawl out to unlatch the switch arm but the switch arm is on the high part of the motor cam so the switches remain closed.

When the notch in the motor cam reaches the switch arm, the arm drops into the notch and opens the switches. This stops the reset motor and interrupts the regeneration signal. The register is now ready for another cycle.

## Section V MAINTENANCE

### 5-1. GENERAL

This section of the manual provides information pertaining to maintenance of the registers. The information consists of preventive maintenance, troubleshooting and corrective maintenance procedures.

#### NOTE

Maintenance of the registers requires adequate test equipment as well as personnel experienced in the checkout and repair of electro-mechanical equipment.

### 5-2. MAINTENANCE EQUIPMENT

The test equipment and tools required for checkout and maintenance of the registers are listed below. Besides those items listed, the only other maintenance equipment required is the usual complement of hand tools used by service technicians.

- a. Voltmeter or test lamp for continuity checks and tests.

### 5-3. PREVENTIVE MAINTENANCE

The purpose of preventive maintenance for the registers is to ensure efficient, trouble-free operation and to discover and correct conditions that can result in damage or instrument failure. Perform the following preventive maintenance procedures on a routine basis.

- a. **CLEANING.** Clean all dust, dirt, moisture or grease from the front panel and housing of the instrument. Use a clean cloth dampened with detergent and water. Wipe dry with a clean cloth.

- b. **INSPECTION.** Visually inspect the instrument for breaks, cuts, wear or deterioration in the power interconnecting wiring and signal wiring. Replace any defective wiring.

#### NOTE

The operator should always note any erratic indications and unusual noises. These are cause for instrument checkout.

- c. **LUBRICATION.** Apply a soft grease such as Lubriplate sparingly to the following points every 6 months.

1. Drive bevel gears.
2. Reset shaft (SR only).

### 5-4. TROUBLESHOOTING

Should a register fail to operate properly, the first step in troubleshooting the instrument is to try to localize the malfunction to a component. The trouble symptoms listed in the troubleshooting chart, Tables 5-1 and 5-2, will aid in determining and locating the difficulty. The chart lists possible troubles, probable causes and remedies. Use the wiring diagrams in Section II as a further aid in isolating the fault.

### 5-5. ADJUSTMENTS — MODEL SR

#### a. SIGNAL SWITCH, SECOND STAGE

Use a test light or an ohmmeter with the power off. Connect to the common and normally-open signal switch terminals. See Figure 5-1.

1. Loosen the switch bracket locking screw slightly with an offset screwdriver.
2. With an Allen wrench, loosen the setscrew in the high-speed cam.
3. By hand, rotate the high-speed cam to position the switch roller in the drop-off zone of the cam.
4. Rotate the low-speed cam (by hand) to position the switch roller in the center of the drop-off zone of this cam.
5. Rotate the high-speed cam until the switch roller is on the drop-off point of the cam. Tighten the setscrew in the high-speed cam.

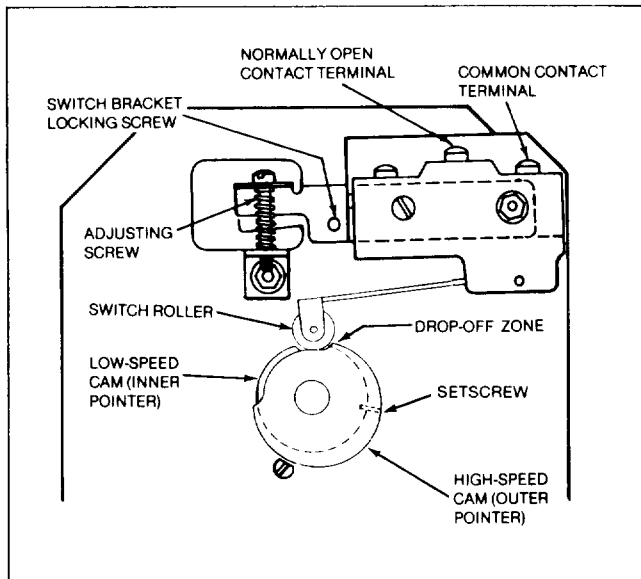

**Figure 5-1. Signal Switch Adjustment  
(Positioning Roller on Cams)**

6. Slowly advance the adjusting screw while slowly turning the register's reset knob to rotate the high-speed cam until only one signal is received during two revolutions of the high-speed cam past the trip point.

**NOTE**

To obtain proper cam adjustment, carefully observe the movement of the switch roller. When the high-speed cam completes one revolution before shut-off, the switch roller must lower into the drop-off zone of the low-speed cam to activate an electrical signal.

7. Tighten the switch bracket locking screw.

8. Recheck cam adjustments by rotating the cams (turn the reset knob) until drop-off points are aligned. The switch roller must be positioned in the center of the low-speed drop-off zone.

9. Recheck operation.

b. **POINTER POSITION.** At the end of a metering cycle with the signal switch closed, the red pointer must be on zero. If necessary, loosen the screw on the hub and reposition pointer. Tighten screw after adjustment.

**5-6. ADJUSTMENTS — MODEL AR**

a. **SWITCH ARM PAWL.** The pawl may require adjustment if the switch arm does not latch.

1. Set the pawl spring tension as shown in Figure 5-2, View A.

2. Bend the pawl tab to obtain latch clearance as shown in Figure 5-2, Views B and C.

3. Rotate the reset pointer so it picks up the red pointer and continues until the switch arm drops into the notch in the motor (rear) cam.

4. Rotate the red pointer (and cam) and observe latching of the switch arm by the pawl. As the high point of the signal cam passes the switch arm, the pawl must engage the notch of the switch arm and latch the arm. (See Figure 5-2, View B.) The switch arm must remain latched when the high point of signal cam is past the switch arm.

b. **SIGNAL AND MOTOR SWITCHES.** (See Figure 5-3.)

1. Slightly loosen three switch mounting arm locking screws.

2. Rotate the register drive if necessary to set the high part of the motor cam (rear) on the switch arm.

3. Back off both adjusting screws so that the signal and motor switches are open (normally-open contacts).

4. Advance the motor switch (rear) adjusting screw until the motor switch closes. Then advance the adjusting screw 1-1/3 turns for proper overtravel.

5. Advance the signal switch (front) adjusting screw until the signal switch closes. Then advance the adjusting screw 1 turn for proper overtravel.

6. Tighten the switch mounting bracket locking screws.

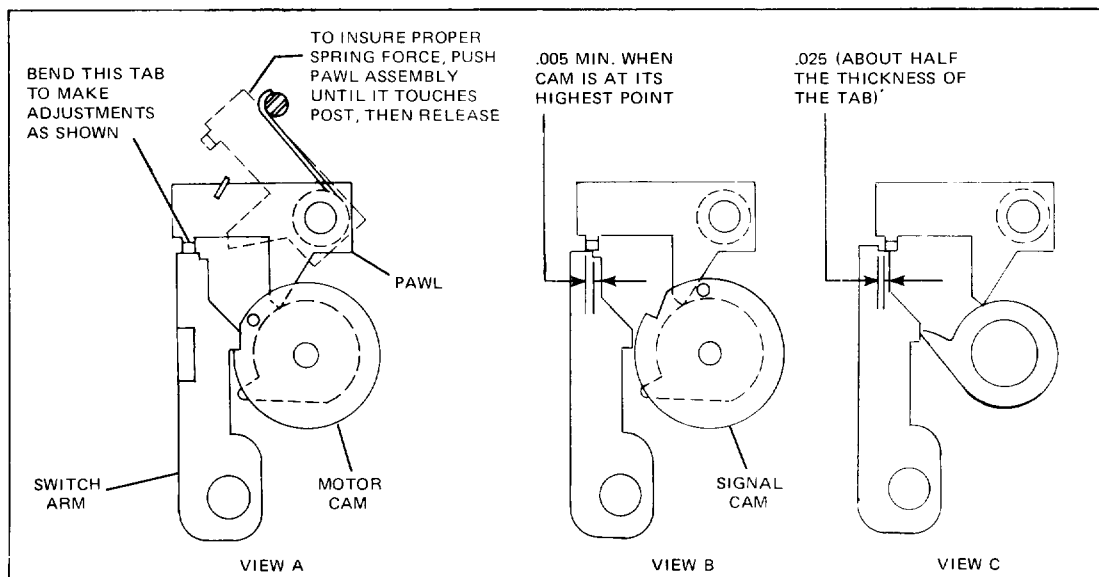

**Figure 5-2. AR Pawl Adjustment**

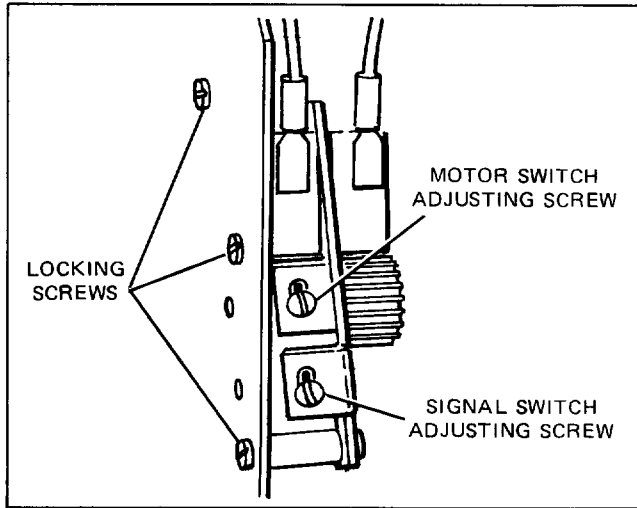

**Figure 5-3. AR Switch Adjustment**

c. DELIVERY POINTER (RED).

1. Rotate the reset pointer counterclockwise until the switch arm drops into the notch in the motor cam.

2. Rotate the red delivery pointer counterclockwise until the motor (rear) switch closes. With this cam position the red pointer should be at zero on the dial. If it is not, remove reset pointer and hub. Loosen the pointer lock screw, set the pointer on zero and tighten the lock screw. Do not move the signal cam during pointer position adjustment. Replace reset pointer and adjust to preset position.

d. PRESETTING. Refer to paragraph 3-3.

### 5-7. CHANGE GEARS

Due to differences in fluid viscosity, specific gravity, temperature, et cetera, the register may not be indicating the correct flow quantity. If this occurs, proceed as follows:

a. Determine the exact register reading for the corresponding quantity of product delivered. Measure quantity exactly.

b. Check the number of teeth on the driven and driver change gears on the rear of the gear plate (See Figure 5-4). The gears are stamped with the number of teeth.

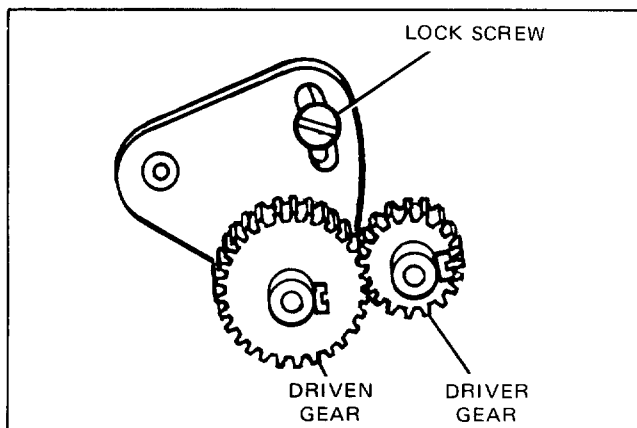

**Figure 5-4. Change Gears**

c. Notify the Flow Products Division of Badger Meter of the data in a and b above. Badger Meter engineering will advise you of required changes to be made.

d. To adjust or interchange the gears, loosen the lock screw and pivot the driven gear away. Replace the change gears if required. Align the gear teeth and setscrews. Swing the driven gear until it meshes with the driver gear and tighten the lock screw.

**NOTE**

Be sure gear teeth mesh fully without any tightness.

### 5-8. PERFORMANCE CHECK — MODEL AR

To test for proper actuation and relay operation (if so equipped), perform an operational performance check. A set of test lights should be used. Different color lamps with corresponding color test leads are suggested for simplicity.

Connect the power source per unit rating with an external switch to the terminals as shown on the applicable wiring diagram in Section II. The external power switch must be open.

a. MODEL AR WITH RELAY (Normally-Open)

1. Connect test lights to the terminal strip as follows:

Test Light No. 1 — to terminals 2 and 3

Test Light No. 2 — to terminals 4 and 6

Test Light No. 3 — to terminals 5 and 6

Test Light No. 4 — to terminal 3 and the normally-closed terminal of the reset motor switch (rear switch — unconnected terminal).

2. Rotate the pointers to the preset position where the switch arm drops into the notch of motor cam.

3. Turn on the power. As the power is turned on the test lights No. 3 and No. 4 must light up.

4. Turn the red pointer counterclockwise to a position close to zero on the dial.

5. Slowly advance the red pointer further by rotating the register drive shaft. As the red pointer reaches zero the test light No. 4 will go out and the reset motor will start. Do not rotate any further.

6. The motor will turn the motor cam and raise the switch arm until it rides on the O.D. of the motor cam. This will close the front or signal switch and energize the relay. Test light No. 3 will go out and test lights No. 1 and No. 2 will light simultaneously.

**NOTE**

Test light No. 4 must go out when the red pointer indicates zero on the dial and before test light No. 3 goes out.

7. The reset pointer (nickel-plated) will pick up the delivery pointer (red) and reset it to the preset position and turn the motor off. This completes the cycle and the test.

b. MODEL AR LESS RELAY (Normally-Open Signal Switch).



1. Connect test lights to the terminal strip as follows:  
 Test Light No. 1 — to terminals 1 and 2  
 Test Light No. 2 — to terminal 1 and the normally-closed terminal of the reset motor switch (rear switch — unconnected terminal).
2. Rotate the pointers to the preset position where the switch arm drops into the notch of motor cam.
3. Turn on the power. As the power is turned on the test light No. 2 must light up.
4. Turn the red pointer counterclockwise to a position close to zero on the dial.
5. Slowly advance the red pointer further by rotating the register drive shaft. As the red pointer reaches zero the test light No. 2 will go out and the reset motor will start. Do not rotate any further.
6. The motor will turn the motor cam and raise the switch arm until it rides on the O.D. of the switch cam. This

will close the front or signal switch and test light No. 1 will light up.

**NOTE**

Test light No. 2 must go out when the red pointer indicates zero on the dial and before the test light No. 1 lights up.

7. The reset pointer (nickel-plated) will pick up the delivery pointer (red) and reset it to the preset position and turn the motor off. This completes the cycle and the test.

**5-9. PARTS REPLACEMENT**

Normal parts replacement includes the microswitches, relay, and possibly gears or cams which are worn. Mounting of these parts is shown in the exploded views in Section VI. Refer to Section VI for parts replacement listings and ordering information.

**Table 5-1. Model AR Troubleshooting Chart**

**NOTE**

Since the AR register is usually a part of a larger control system not supplied by Badger Meter, Inc., it is necessary that the system is checked to be sure it is installed properly and wired in accordance with the manufacturer's recommendations before changing any adjustments or troubleshooting is done on the AR register.

POSSIBLE TROUBLE	PROBABLE CAUSE	REMEDY
Pointers do not return to proper preset.	<ol style="list-style-type: none"> <li>1. Loose reset pointer screws.</li> <li>2. Malfunctioning or faulty motor switch.</li> </ol>	<ol style="list-style-type: none"> <li>1. Re-adjust preset and tighten screws.</li> <li>2. Check switch actuation and mounting. Adjust if required. Replace if defective.</li> </ol>
Register does not stop at zero.	<ol style="list-style-type: none"> <li>1. Loose delivery pointer screw.</li> </ol>	<ol style="list-style-type: none"> <li>1. Re-adjust position of pointer.</li> </ol>
Register does not stop.	<ol style="list-style-type: none"> <li>1. Malfunctioning or faulty signal switch.</li> </ol>	<ol style="list-style-type: none"> <li>1. Check switch actuation and mounting. Adjust if required. Refer to para. 5-6 a.</li> </ol>
Register does not reset.	<ol style="list-style-type: none"> <li>1. Malfunctioning motor switch.</li> <li>2. Faulty motor switch.</li> <li>3. Loose motor cam.</li> <li>4. Broken pawl spring.</li> <li>5. Faulty reset motor.</li> </ol>	<ol style="list-style-type: none"> <li>1. Check switch actuation. Re-adjust if required. Refer to para. 5-6 a.</li> <li>2. Check operation of switch. Replace if defective.</li> <li>3. Secure motor cam. Re-adjust.</li> <li>4. Replace spring and adjust pawl.</li> <li>5. Replace motor.</li> </ol>
Delivery pointer does not move.	<ol style="list-style-type: none"> <li>1. Loose gear.</li> </ol>	<ol style="list-style-type: none"> <li>1. Check setscrews in gears for looseness. Tighten.</li> </ol>

**Table 5-2. Model SR Troubleshooting Chart**

POSSIBLE TROUBLE	PROBABLE CAUSE	REMEDY
Switch does not close or open.	1. Malfunctioning or faulty signal switch.	1. Check switch actuation and mounting. Adjust if required. Replace if defective.
Register pointer(s) do not move.	1. Loose gear.	1. Check setscrews on gears for looseness. Tighten.

For other malfunctions of the system check external equipment as recommended by the manufacturer.

## Section VI

### ILLUSTRATED PARTS LIST

#### 6-1. PART LOCATION ILLUSTRATIONS

The location and identification of the assemblies and parts comprising Models AR and SR are shown on the exploded view illustrations. Each assembly or part shown on the illustrations is identified by an index number that is cross-referenced to an associated parts list.

#### 6-2. PARTS LISTS

The parts lists consist of columnar lists of the assemblies and parts that are shown in the part location illustrations and provide the following information for each item listed.

- a. FIGURE AND INDEX NUMBER.
- b. PART NUMBER.
- c. DESCRIPTION.

#### 6-3. ORDERING INFORMATION

Order replaceable parts for applicable register through the local Badger Meter Sales Representative or directly from the Industrial Sales Department, Flow Products Division of Badger Meter, Inc. (address on title page). When placing an order, provide the following information:

- a. Complete name plate data.
- b. Dial capacity and number of fixed digits behind the totalizer.
- c. Complete description of the assembly or parts required.
- d. Part number of the item as indicated in the parts list.
- e. Quantity of parts required.
- f. A purchase order number and exact return and billing address.

		Spec. data
Model		Model
Part No.		Part No.
Manufactured by Badger Meter, Inc. Milwaukee, Wisconsin 53223		

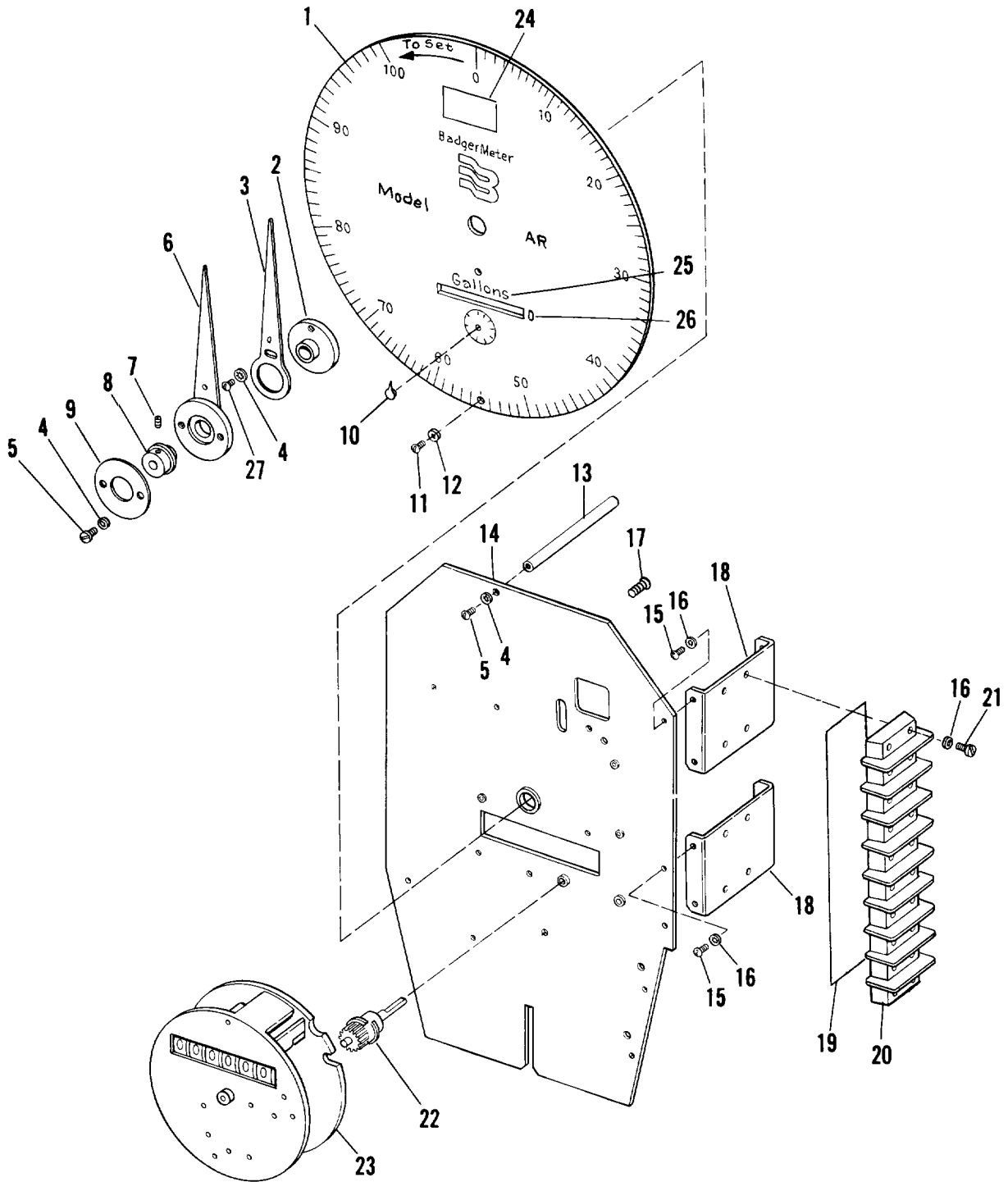

Figure 6-1. Model AR Front Plate

FIG. 6-1 ITEM NO.	PART NO.	DESCRIPTION
1	56599-00300	Dial — 100 Gal. Capacity
1	56599-00400	Dial — 200 Gal. Capacity
1	56599-00500	Dial — 500 Gal. Capacity
2	56948-00100	Delivery Pointer Hub Assy.
3	24349-00000	Delivery Pointer
4	20454-00000	Lockwasher #3
5	55090-08600	Pan Head Screw — 3-48 x 3/16
6	56949-00100	Preset Pointer Assembly
7	21451-00000	Set Screw — 4-48 x 1/8
8	30089-00000	Preset Pointer Hub
9	30090-00000	Pointer Retainer Plate
10	33319-00000	Pointer
11	31820-00000	Pan Head Screw — 2-32 x 5/16
12	55293-00300	Lockwasher
13	21700-00000	Spacer Post
14	56678-00300	Front Plate Assembly
15	55109-16700	Round Head Screw — 6-32 x 3
16	55294-00700	Lockwasher #6
17	31820-00400	Flat Head Screw — 2-32 x 3/8
18	56664-00100	Terminal Mounting Bracket
19	31898-00800	Marker Strip, 8-Term. AR w/Relay
19	31898-00900	Marker Strip, 6-Term. AR less/Relay
20	22800-01800	Terminal Strip, 8-Term. AR w/Relay
20	22800-01700	Terminal Strip, 6-Term. AR less/Relay
21	55090-17200	Pan Head Screw — 6-32 x 1/2
22	56630-00100	Spindle and Cam Assembly
23	56950-00100	Totalizer Assembly
24	56600-00500	1000 Capacity Label x 10
24	56600-00500	2000 Capacity Label x 10
24	56600-00500	5000 Capacity Label x 10
24	56600-00600	10M Capacity Label x 100
24	56600-00600	20M Capacity Label x 100
24	56600-00600	50M Capacity Label x 100
24	56600-00700	100M Capacity Label x 1000
24	56600-00700	200M Capacity Label x 1000
24	56600-00700	300M Capacity Label x 1000
24	56600-00800	1000M Capacity Label x 10,000
24	56600-00800	2000M Capacity Label x 10,000
24	56600-00800	5000M Capacity Label x 10,000
24	56600-00900	10,000M Capacity Label x 100M
25	56600-00200	Label — Liters
25	56600-00300	Label — M <sup>3</sup>
25	56600-01400	Label — Imp. Gallons
25	56600-01000	100 Test Circle Label — 00
25	56600-01100	1000 Test Circle Label — 000
26	56600-01500	.1 Test Circle Label — x .1
26	56600-01600	Blank Label
27	55109-08600	Round Head Screw — 3-48 x 3/16

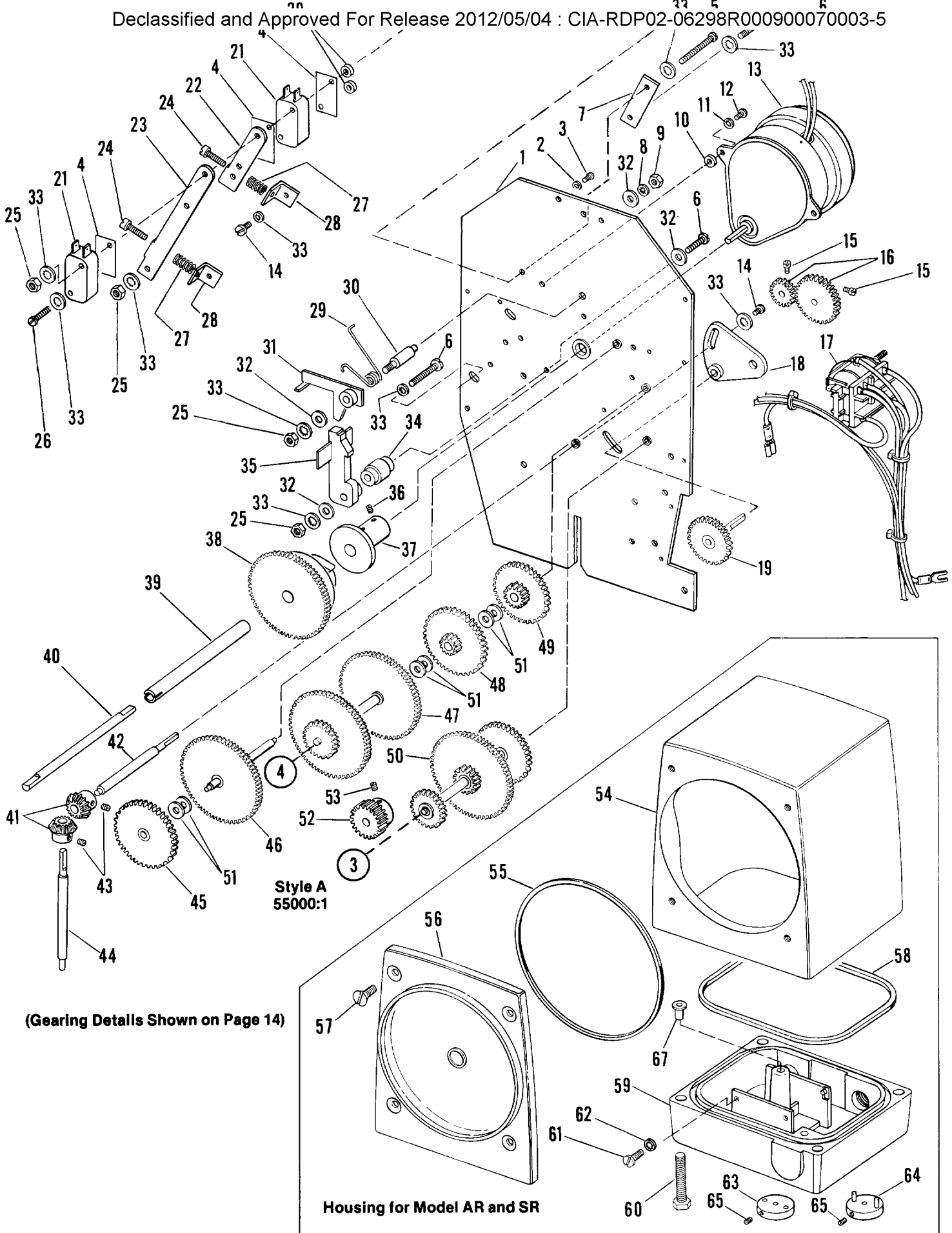

Figure 6-2. Model AR Back Plate

FIG. 6-2 ITEM NO.	PART NO.	DESCRIPTION	FIG. 6-2 ITEM NO.	PART NO.	DESCRIPTION
1	56679-00300	Back Plate Assembly	32	22562-01300	Flat Washer
2	20454-00000	Lockwasher No. 3	33	55292-00500	Lock Washer No. 4 Int. Teeth
3	55090-08600	Rd. Head Screw — 3-48 x 3/16	34	56656-00100	Post, Pivot Switch Arm
4	24579-00100	Insulation	35	24580-00100	Switch Arm
5	55089-12600	Pan Head Screw — 4-40 x 1-3/8	36	55230-16500	Set Screw No. 6-32 x 1/8
6	55089-12200	Pan Head Screw — 4-40 x 7/8	37	24336-00000	Motor Cam Assembly
7	56639-00100	Switch Retaining Plate	38	56660-00100	Clutch and Gear Assembly
8	55283-00700	Lockwasher No. 6	39	56648-00100	Shaft, Delivery Pointer
9	55002-03400	Hex Nut No. 6	40	56652-00100	Spindle No. 7 — Preset Pointer
10	23983-02800	Spacer	41	20398-00000	Miter Gear
11	55270-00500	Lockwasher	42	56634-00100	Drive Spindle
12	55046-11400	Pan Head Screw — 4-40 x 1/4	43	55230-16500	Set Screw No. 6-32 x 1/8
13	24335-00000	Motor — 110 V, 60 Hz., 20 rph	44	56649-00100	Input Spindle
13	24335-00100	Motor — 24 V, 60 Hz., 20 rph	45	56670-00100	Gear and Pinion Assy. Style A & B
13	24335-00200	Motor — 220 V, 50 Hz., 20 rph	46	56960-00400	Gear & Spindle Assy. Style A,B,C, & D
13	24335-00300	Motor — 110 V, 60 Hz., 4 rph	47	56959-00500	Gear & Spindle Assy. Style A
14	55109-11300	Rd. Head Screw — 4-40 x 3/16	48	56670-00500	Style A Gear and Hub Assembly
*15	1065-00000	Set Screw	49	56676-00100	Style A Gear and Pinion Assy.
*16	32652-00000	Change Gear — Spec. No. Teeth	50	56955-00100	Style A Gear & Spindle Assy.
*17	56966-00100	AR Relay w/Wire Harness, 110 V	51	22562-01200	Flat Washer
17	56966-00200	AR Relay w/Wire Harness, 220 V	52	34780-00100	Gear — 20 Teeth
17	56966-00300	AR Relay w/Wire Harness, 24 V	53	55230-11300	Set Screw — 4-40 x 3/16
17	53841-00100	Wire Harness, AR less Relay	54	56564-00100	Housing
18	56867-00100	Adjusting Plate	55	22559-01600	Tetraseal
19	56673-00100	Change Gear Spindle Assy.	56	56563-00100	Lens and Bezel
20	31239-00100	Spacer — .109 Long	57	55068-27400	Flat Head Screw — 1/4-20 x 3/8
*21	24574-00100	Switch	58	22559-04200	Tetraseal
22	56654-00100	Switch Adj. Bracket — Short	59	56750-00100	Base
23	56655-00100	Switch Adj. Bracket — Long	60	55030-11800	Hex Capscrew — 1/4-20 x 1-3/4
24	55046-12300	Fil. Head Screw — 4-40 x 5/8	61	55109-19700	Round Head Screw — 8-32 x 3/8
25	55002-03200	Hex Nut — 4-40	62	55294-00800	Lockwasher No. 8
26	55089-11800	Pan Head Screw — 4-40 x 1/2	63	56646-00200	Coupling — Upper
27	22602-00900	Spring	64	56646-00300	OP Meters Coupling — Lower
28	56736-00100	Switch Adjustment Bracket	64	56646-00100	Other Meters Coupling — Lower
29	24334-00000	Spring	65	21451-00000	Set Screw — 4-48 x 1/8
30	24333-00000	Pawl Pivot Post	66	22562-00900	Flat Washer (Gear Spacer)
31	24330-00000	Pawl and Hub Assembly	67	56691-00100	Bushing

\*Recommended Spare Parts

For gear reductions, see table 6-1

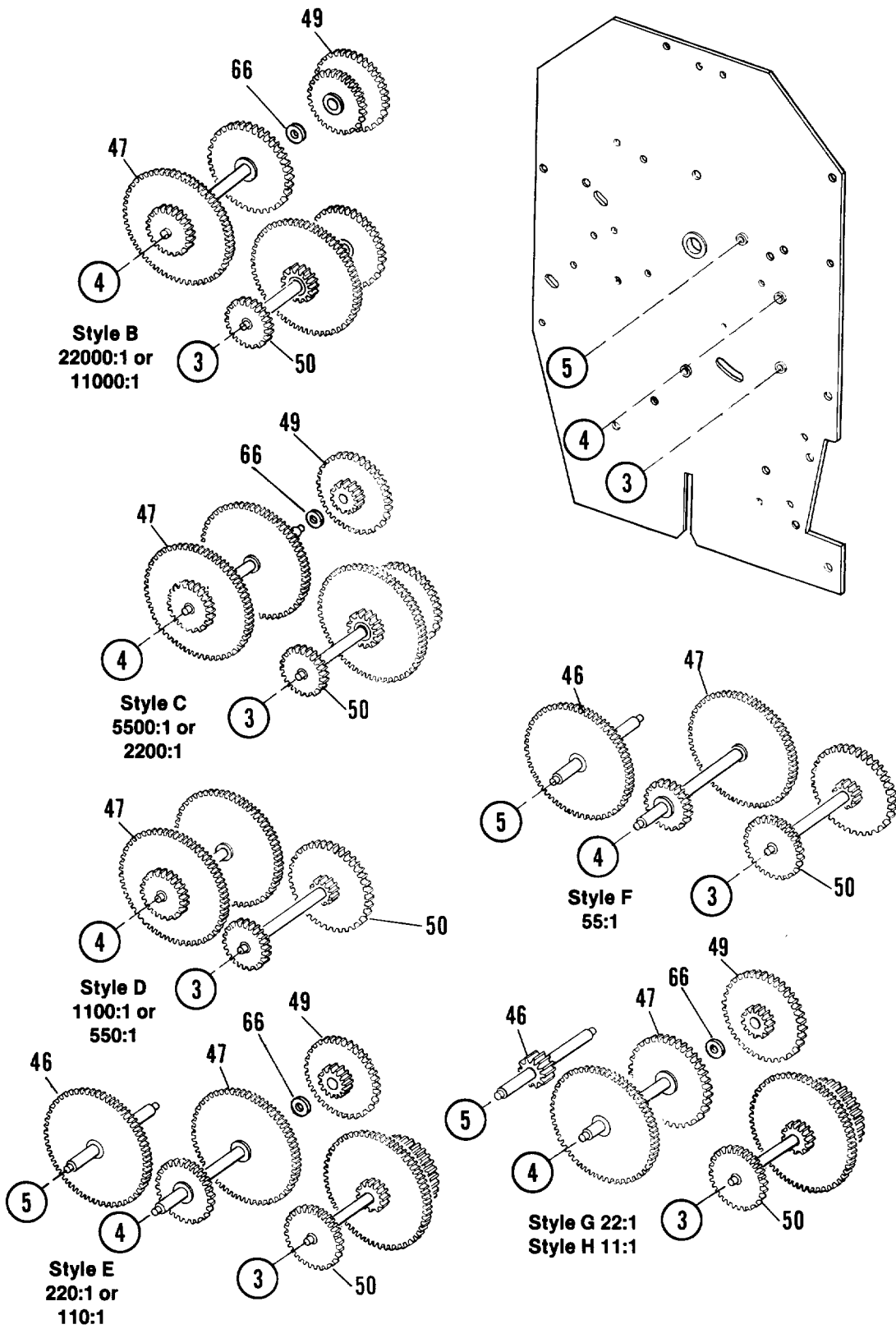

Figure 6-2. (Continued) Model AR Gearing

FIG. 6-2 ITEM NO.	PART NO.	DESCRIPTION
45	56670-00100	Style A & B Gear & Pinion Assy.
45	56670-00100	Style C Gear & Pinion Assy. (5500:1)
45	56670-00700	Style C Gear & Pinion Assy. (2200:1)
45	56670-00700	Style D Gear & Pinion Assembly
46	56960-00400	Style A,B,C, & D Gear & Spindle Assy.
46	56960-00600	Style E & F Gear and Spindle Assembly
46	56960-00300	Style G & H Gear and Spindle Assembly
47	56959-00500	Style A Gear and Spindle Assembly
47	56960-00100	Style B Gear and Spindle Assembly
47	56957-00400	Style C Gear & Spindle Assy. (5500:1)
47	56957-00500	Style C Gear & Spindle Assy. (2200:1)
47	56958-00100	Style D Gear & Spindle Assy. (1100:1)
47	56958-00200	Style D Gear & Spindle Assy. (550:1)
47	56957-00100	Style E Gear and Spindle Assembly
47	56958-00600	Style F Gear and Spindle Assembly
47	56960-00200	Style G Gear and Spindle Assembly
47	56957-00200	Style H Gear and Spindle Assembly
48	56670-00500	Style A Gear and Hub Assembly
49	56676-00100	Style A Gear and Pinion Assembly
49	56670-00100	Style B Gear Pinion Assy. (22000:1)
49	56670-00400	Style B Gear & Pinion Assy. (11000:1)
49	56670-00600	Style C Gear & Pinion Assy. (5500:1)
49	56676-00100	Style C Gear & Pinion Assy. (2200:1)
49	56670-00600	Style E Gear & Pinion Assy. (220:1)
49	56676-00100	Style E Gear & Pinion Assy. (110:1)
49	56670-00400	Style G Gear and Pinion Assembly
49	56670-00600	Style H Gear and Pinion Assembly
50	56955-00100	Style A Gear & Spindle Assembly
50	56956-00200	Style B Gear & Spindle Assy. (22000:1)
50	56956-00300	Style B Gear & Spindle Assy. (11000:1)
50	56955-00200	Style C Gear & Spindle Assy. (5500:1)
50	56955-00300	Style C Gear & Spindle Assy. (2200:1)
50	56956-00400	Style D Gear & Spindle Assy. (1100:1)
50	56956-00500	Style D Gear & Spindle Assy. (550:1)
50	56955-00400	Style E Gear & Spindle Assy. (220:1)
50	56955-00500	Style E Gear & Spindle Assy. (110:1)
50	56956-00400	Style F Gear and Spindle Assembly
50	56956-00100	Style G Gear and Spindle Assembly
50	56955-00600	Style H Gear and Spindle Assembly



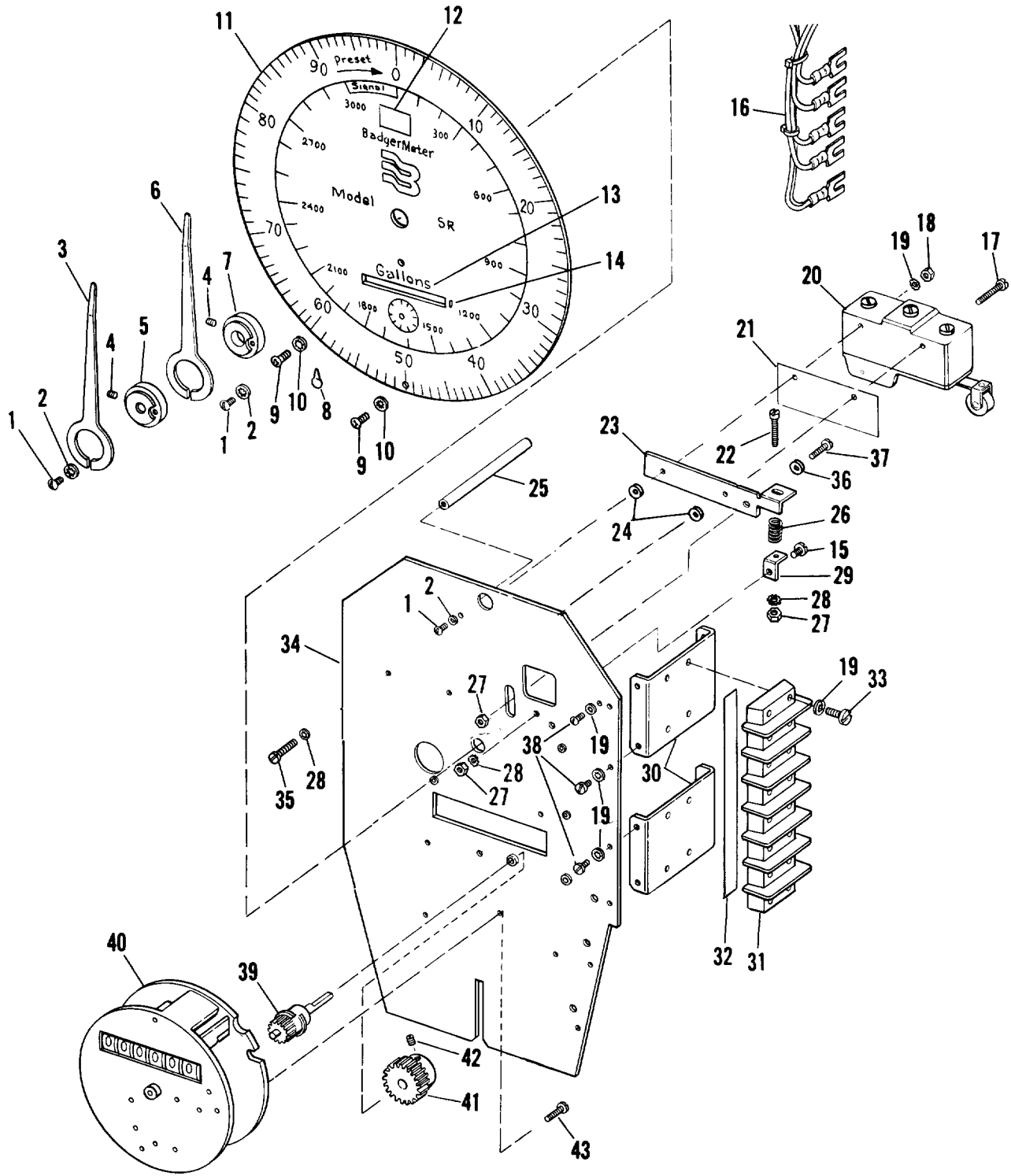

Figure 6-3. Model SR Front Plate

FIG. 6-3 ITEM NO.	PART NO.	DESCRIPTION
1	55090-08600	Pan Head Screw — 3-48 × 3/16
2	20454-00000	Lockwasher No. 3
3	22859-00000	Outer Pointer
4	21451-00000	Set Screw — 4-48 × 1/8
5	22860-00000	Outer Pointer Hub
6	22859-00100	Inner Pointer
7	56962-00100	Inner Pointer Hub Assembly
8	33319-00000	Test Circle Pointer
9	31820-00000	Pan Head Screw — 2-32 × 5/16
10	55293-00300	Lockwasher No. 2
11	56599-00100	Dial
12	56600-00500	30,000 Capacity Label × 10
12	56600-00600	300,000 Capacity Label × 100
12	56600-00700	3,000,000 Cap. Label × 1000
13	56600-00200	Label — Liters
13	56600-01400	Label — Imp. Gallons
13	56600-00300	Label — M <sup>3</sup>
14	56600-01000	100 Test Circle Label — 00
14	56600-01100	1000 Test Circle Label — 000
14	56600-01500	.1 Test Circle Label — × .1
14	56600-01600	Blank Label
15	55090-11500	Pan Head Screw — 4-40 × 5/16
16	56844-00100	Wiring Harness
17	55109-17500	Round Head Screw — 6-32 × 3/4
18	55002-03400	Hex Nut — 6-32
19	55294-00700	Lockwasher No. 6
*20	24574-00500	Signal Switch
21	56872-00100	Insulation
22	55046-12300	Fil. Head Screw — 4-40 × 5/8
23	56734-00100	Switch Adjusting Bracket
24	22562-00100	Flat Washer
25	21700-00000	Spacer Port
26	22602-02500	Spring
27	55002-03200	Hex Nut — 4-40
28	55291-00500	Lockwasher No. 4
29	56736-00100	Switch Adjusting Bracket
30	56664-00100	Terminal Mounting Bracket
31	22800-01400	Terminal Strip — 4 Term.
32	31898-01000	Marker Strip — 4 Term.
33	55090-17200	Pan Head Screw — 6-32 × 1/2
34	56678-00100	Front Plate Assembly
35	55109-17700	Round Head Screw — 6-32 × 1
36	55291-00500	Lockwasher No. 4
37	55089-11400	Pan Head Screw — 4-40 × 1/4
38	55109-16700	Round Head Screw — 6-32 × 3/16
39	56630-00100	Cam Spindle Assembly
40	56950-00100	Totalizer Assembly
41	34780-00100	Gear — 20 Teeth
42	55230-11300	Set Screw — 4-40 × 3/16
43	31820-00400	Flat Head Screw — 2-32 × 3/8

\*Recommended Spare Parts

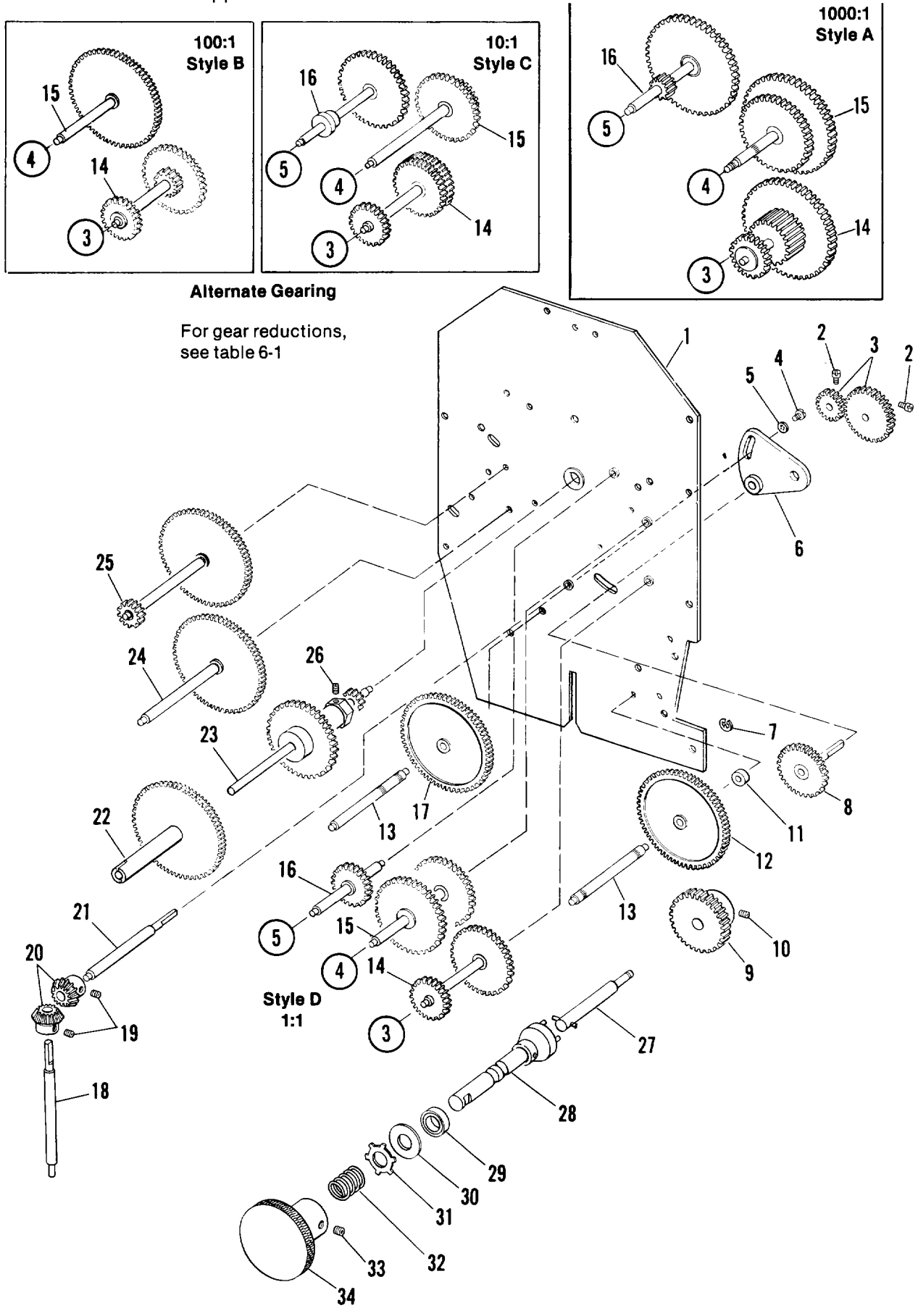

Figure 6-4. Model SR Back Plate and Gearing

FIG. 6-4 ITEM NO.	PART NO.	DESCRIPTION
1	56679-00100	Back Plate Assembly
*2	1065-00000	Set Screw — 4-48
*3	32652-00000	Change Gear — Spec. No. Teeth
4	55109-11300	Round Head Screw — 4-40 x 3/16
5	55283-00500	Lockwasher No. 4
6	56867-00100	Adjusting Plate Assembly
7	22570-00300	"E" Ring
8	56673-00100	Change Gear Spindle Assembly
9	26459-03000	Drive Pinion — 30 Teeth
10	55230-11300	Set Screw — 4-40 x 3/16
11	56708-00100	Spacer
12	56720-00100	Gear Cluster — 50 Teeth
13	56711-00100	Spindle
14	56955-00700	Style A Gear & Spindle Assy.
14	56956-00400	Style B Gear & Spindle Assy.
14	56956-00600	Style C Gear & Spindle Assy.
14	56955-00800	Style D Gear & Spindle Assy.
15	56960-00500	Style A Gear & Spindle Assy.
15	56958-00400	Style B Gear & Spindle Assy.
15	56958-00500	Style C Gear & Spindle Assy.
15	56959-00100	Style D Gear & Spindle Assy.
16	56959-00300	Style A Gear & Spindle Assy.
16	56959-00300	Style B Gear & Spindle Assy.
16	56959-00400	Style C Gear & Spindle Assy.
16	56959-00200	Style D Gear & Spindle Assy.
17	56710-00100	Gear & Hub Assy. — 60 Teeth
18	56649-00100	Input Spindle
19	55230-16500	Set Screw — 6-32 x 1/8
20	20398-00000	Miter Gear
21	56634-00100	Drive Spindle
22	56706-00200	Gear & Cam Assy. — 77 Teeth
23	56705-00600	Clutch Spindle Assy., Style A, B & C
23	56705-00700	Clutch Spindle Assy., Style D
24	56957-00300	Spindle Assembly
25	56958-00300	Spindle Assembly
26	55234-11100	Set Screw — 4-48 x 1/8
27	56961-00100	Reset Spindle
28	56787-00100	Reset Knob Spindle Assembly
29	22877-00400	"V" Ring
*30	22562-02300	Flat Washer
31	56751-00100	Retaining Ring
32	22602-02400	Spring
*33	55230-19400	Set Screw — 8-32 x 3/16
*34	24399-00000	Control (Preset) Knob

\*Recommended Spare Parts

**Table 6-1. Gear Reduction Versus Dial Capacities****MODEL AR AUTOMATIC RESET REGISTER**

METER SIZE	REGISTER TEST CIRCLE	DIAL CAPACITY	REDUCTION RATIO
5/8" Through 1"	10	100	11:1
	10	200	22:1
	10	500	55:1
	10	1,000	110:1
	10	2,000	220:1
	10	5,000	550:1
	10	10,000	1,100:1
	10	20,000	2,200:1
	10	50,000	5,500:1
	10	100,000	11,000:1
1-1/2" Through 3"	100	1,000	11:1
	100	2,000	22:1
	100	5,000	55:1
	100	10,000	110:1
	100	20,000	220:1
	100	50,000	550:1
	100	100,000	1,100:1
	100	200,000	2,200:1
	100	500,000	5,500:1
	100	1,000,000	11,000:1
4" and Over	1,000	50,000	55:1
	1,000	100,000	110:1
	1,000	200,000	220:1
	1,000	500,000	550:1
	1,000	1,000,000	1,100:1
	1,000	2,000,000	2,200:1
	1,000	5,000,000	5,500:1
	1,000	10,000,000	11,000:1

**MODEL SR SIGNAL REGISTERS**

METER SIZE	REGISTER TEST CIRCLE	OUTER CIRCLE	INNER CIRCLE	REDUCTION RATIO
5/8" Through 1"	10	100	3,000	10:1
	10	1,000	30,000	100:1
	10	10,000	300,000	1,000:1
1-1/2" Through 3"	100	100	3,000	1:1
	100	1,000	30,000	10:1
	100	10,000	300,000	100:1
	100	100,000	3,000,000	1,000:1
4" and Above	1,000	1,000	30,000	1:1
	1,000	10,000	300,000	10:1
	1,000	100,000	3,000,000	100:1

## WARRANTY

Badger warrants meters and parts manufactured by it and supplied hereunder to be free from defects in materials and workmanship for a period of 18 months from date of shipment or 12 months from date of installation, whichever period shall be shorter. If within such period any meters or parts shall be proved to Seller's satisfaction to be defective, such meters or parts shall be repaired or replaced at Seller's option. Seller's obligation hereunder shall be limited to such repair and replacement and shall be conditioned upon Seller's receiving written notice of any alleged defect within 10 days after its discovery and, at Seller's option, return of such meters or parts to Seller f.o.b. its factory. THE FOREGOING WARRANTY IS EXCLUSIVE AND IN LIEU OF ALL OTHER EXPRESS OR IMPLIED WARRANTIES WHATSOEVER INCLUDING BUT NOT LIMITED TO IMPLIED WARRANTIES (EXCEPT OF TITLE) OF MERCHANTABILITY AND FITNESS FOR A PARTICULAR PURPOSE. Badger shall not be liable for any defects attributable to acts or omissions of others after shipment, nor any consequential, incidental or contingent damage whatsoever.

# INSTRUCTION BULLETIN

for

## SERIES 71K1020 FLOW INDICATORS

Design Level C

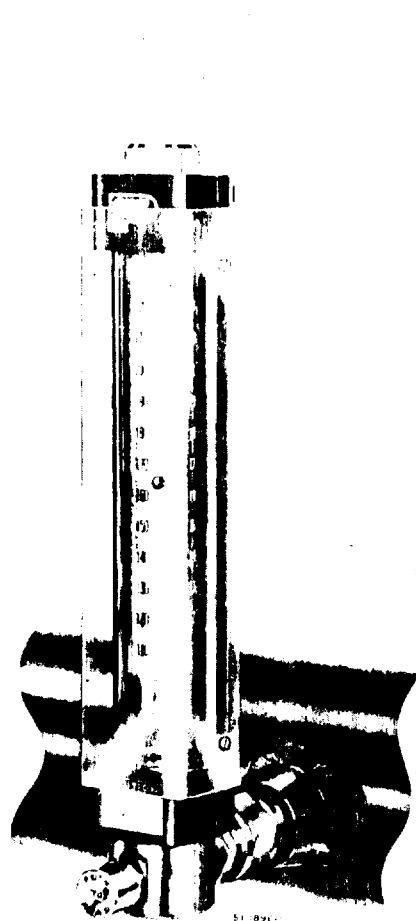

Bushing Mounted

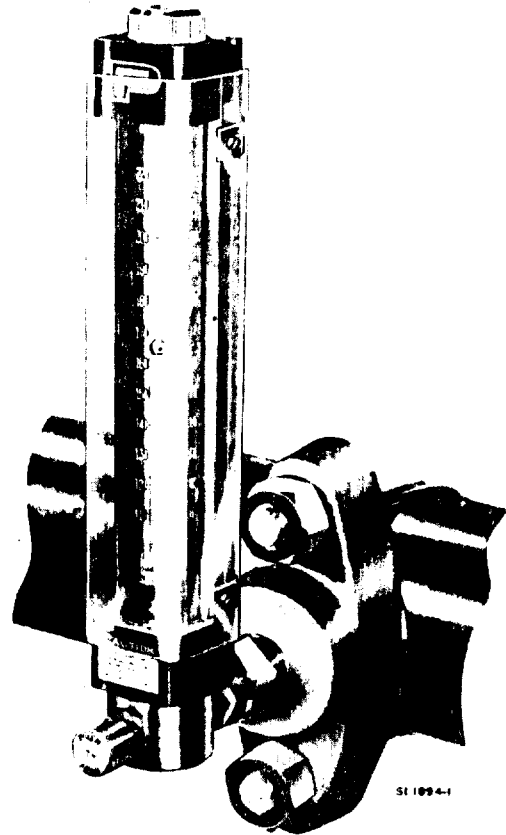

Service Clamp Mounted

FISCHER  
& PORTER **F**

**IMPORTANT**

It is imperative that the following precautionary measures be observed in order to minimize, and hopefully eliminate, the possibility of operator injury.

1) Glass meter tubes have been designed to operate up to maximum design working pressures listed herein. This is not to be construed as a certification that the tubes will not break at any pressure. Inherent material limitations can result in tube breakage due to conditions beyond our control. For example; glass is a brittle material which may break upon impact or if subjected to thermal shock; glass is notch sensitive in that scratches, nicks or cracks may result in breakage when pressurized; incorrect installation or faulty operating methods can cause tube breakage regardless of operating pressure.

2) Glass meter tubes are not recommended for either hot or strong alkalis, fluorine, hydrofluoric acid, steam or water over 200°F (93°C). Glass meter tubes should be periodically inspected for signs of wear. Erosion, stress cracks, nicks or deep scratches provide early warning for tube replacement. With certain fluids, the glass may erode evenly so wear is not visibly noticeable. If wear is suspected, the tube should be replaced in order to eliminate this potential cause of meter tube breakage.

3) It is important that all materials of construction be compatible with the service to which the meter is applied. It is especially important that "O" ring material be compatible with the process fluid. Glass meter tube breakage can occur in those meters using an "O" ring as an internal seal if the improper material is used. Refer to F&P Co. Catalog 10A1023, Rotameter Selection Guide, material selection.

4) The Meter should never be subjected to excessive vibration.

5) Remove pressure from the Flow Indicator before attempting to remove the meter tube.

6) Be sure the set screws that serve to lock the meter end fittings in place are secure. This should be checked before the Flow Indicator is put into service or returned to service after maintenance. Loose end fittings may result in glass meter tube breakage.

7) The glass meter tube should be periodically inspected and replaced if cracked, nicked, scratched or worn.

8) Do not operate the Flow Indicator without the operator protection shield in place. To do so may result in operator bodily injury.

**MODEL NUMBERING**

Refer to the F&P data sheet or the meter data tag for the model number of the equipment furnished. The model number breakdown is as follows:

71 K 102 A A XX

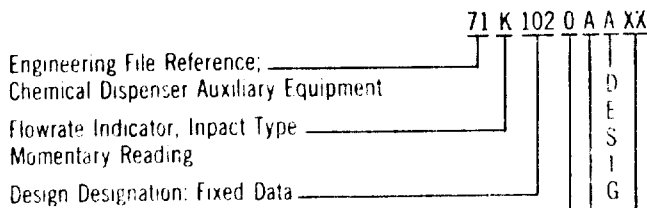

Capacity	Pipe Size in inches	Flowrate gpm	
		Min	Max
1	1-1/2	8	80
	2	10	135
	2-1/2	15	195
	3	30	300
2	4	40	520
	5	80	820
	6	100	1200
	8	200	2100
5	10	300	3300
	12	400	4600
	14	400	5600
	16	600	7400

**Note**  
Return tube has four scales. Purchase a service clamp or pipe bushing per the actual pipe size. Pipe bushing cannot be used for 1-1/2" pipe.

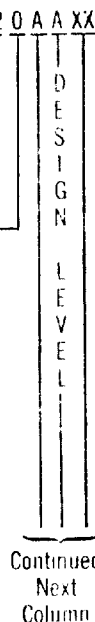

"O" Ring Material  
 A = Buna N  
 B = Butyl } Discontinued as standard  
 C = Viton }

Design Level: Letter assigned by factory; letter changes when some part is no longer interchangeable.

- A = Original Design
- B = Ball Float changed to Black Glass; Range Orifice changed to accommodate float.
- C = Added Operator Protection Shield, Bushing mount option and 10" thru 16" pipe sizes. } Discussed in this Bulletin

Pipe Size

Pipe Size	Accessory	
	Service Clamp	Pipe Bushing
1-1/2	A	N/A
2	B	A
2-1/2	C	A
3	D	B
4	E	B
5	F	B
6	G	B
8	H	B

= Not Furnished

10	J	C
12	K	C
14	L	C
16	M	C





where at least 10 straight pipe diameters upstream of the meter are available if at all possible; for an installation in 1-1/2" pipe, 20 pipe diameters is preferred. Items that create flow pattern disturbance, such as valves and elbows, should be avoided.

The installation may be made in a vertical, horizontal or sloped run of pipe; however, the meter must be vertical and plumb. Flow may be in either direction through the pipe.

### CAUTION

When the main pipe line is drained, liquid is trapped in the Flow Indicator. If subject to freezing temperature, the meter tube can be broken. Drain the liquid from the meter tube by removing the drain and vent screws and pushing in the reading knob.

## II. Service Clamp Mounted

Drill a 1/2" (13mm) hole horizontally through the center of the pipe, as indicated in Figure 1. Attach the service clamp (optional accessory, at extra cost) to the pipe line, being certain that the tapped hole in the clamp is centered over the hole in the pipe. As shown in Figure 2, the clamp has a gasket that must be included between the pipe and the clamp.

After the service clamp is attached to the pipe line, back off the meter gland nut and remove the adaptor bushing from the impact tube. Assemble the adaptor bushing to the service clamp using pipe dope or a sealing tape on this joint to prevent leakage. Mount the meter and while holding it in a vertical position, tighten the gland nut securely.

### NOTE

Make certain that the impact tube is not being forced against the edge of the hole that was drilled into the pipe.

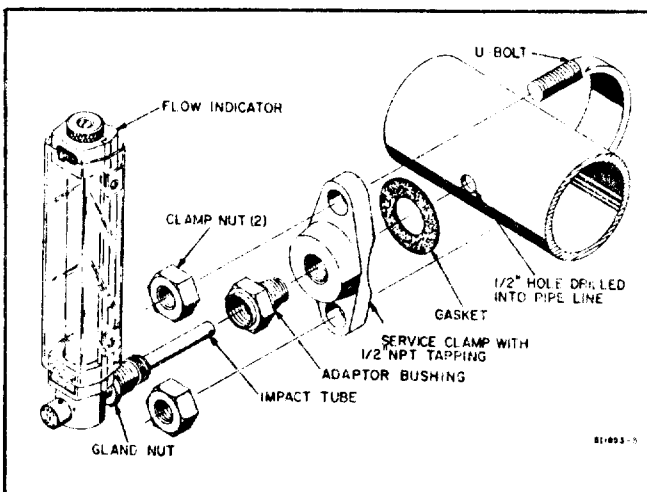

FIGURE 2 METHOD OF MOUNTING WITH SERVICE CLAMP

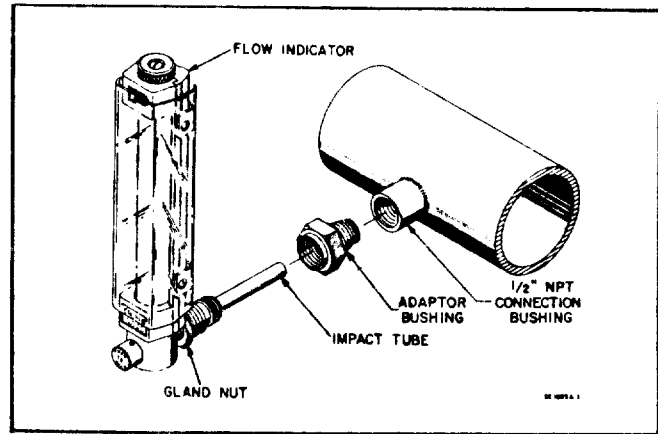

FIGURE 3 METHOD OF MOUNTING WITH BUSHING

## III. Bushing Mounted

Drill a hole horizontally in the pipe line to suit the bushing as indicated in Figure 1. Position the bushing (optional accessory, at extra cost) over the drilled hole and weld in place as shown in Figure 3. It is suggested that a piece of 1/2" pipe be threaded into the bushing while it is being welded so that the horizontal alignment can be checked. Check that the dimension given from the face of the bushing to the pipe OD is correct.

After the bushing is in place, back off the meter gland nut and remove the adaptor bushing from the impact tube. Assemble the adaptor bushing to the bushing using pipe dope or a sealing tape on this joint to prevent leakage. Mount the meter and while holding it in a vertical position, tighten the gland nut securely.

## PLACING IN OPERATION

### NOTE

During the following procedure, the scale tube will be turned to the scale that matches the pipe size. The polycarbonate operator protection shield should not be removed for this procedure.

Each meter can be used on four pipe line sizes. The meter has a scale tube (with four separate scales) which surrounds the metering tube. This scale tube must be turned to the proper position either before or after the meter is installed.

To adjust the position of the scale tube a 3/32" hex key wrench and a 3/8" open end wrench are used. The insert on Figure 5 shows the location and procedure for turning the scale tube.

Adjust the impact tube as discussed in the following steps.

1) Using the 1/16" hex key wrench provided, loosen the set screw in the 'Push to Read' knob several turns and pull the knob from the stem.

2) Turn on the flow of liquid in the pipe line (if it is not already on). With a screwdriver, depress the valve stem, as shown in Figure 4, until the first step is flush with the meter fitting.

#### NOTE

Do not depress the valve stem beyond the first step.

Align the impact tube opening with the fluid stream by rotating the valve stem one complete revolution in either direction, observing the highest scale reading. Rotate the valve stem to the highest reading and stop.

3) Temporarily replace the 'Push to Read' knob but do not tighten the set screw. Push the knob in and simultaneously open the top vent screw of the meter to remove any entrapped air. When the vent is closed, release and remove the valve knob again.

4) Depress the valve stem with a screwdriver and make a final calibration adjustment to obtain the highest reading possible.

5) Replace the knob and tighten the set screw to complete the procedure.

## MAINTENANCE

### I. Cleaning the Meter Tubes

Since the Flow Indicator is normally shut off, it will remain reasonably clean for long periods of time. If the scale tube and the meter tube get dirty, they are easily removed for cleaning even with the main line pressurized.

Refer to Figure 5, the exploded view, as an aid to cleaning the meter. To remove the meter tubes:

1) Remove the operator protection shield and drain the meter by removing the drain screw and vent screw.

2) Loosen the top set screw that holds the protection shield bracket using a 3/32" hex key wrench.

3) Rotate the knurled return flow fitting in a lifting motion. Usually, the scale tube will lift out of the meter with the fitting. If it doesn't, remove the fitting and then the scale tube through the top of the meter.

4) Lift the meter tube assembly (tube, float, guide and float stop) through the top of the meter.

5) From the meter tube, remove the meter tube guide and float stop. With one hand over the top of the tube, invert the tube to remove the ball float.

6) Clean both tubes and the float with a mild detergent and water. A tube brush is useful for cleaning the inside of the tubes.

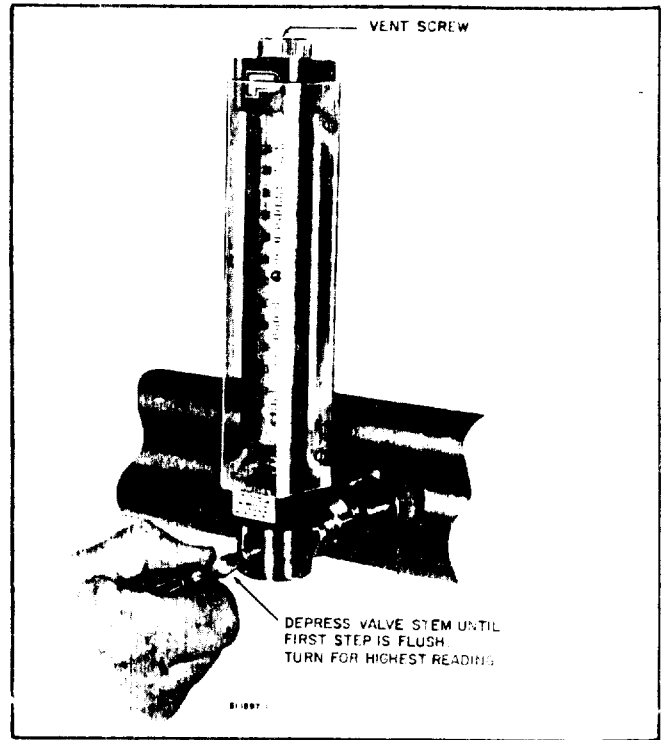

FIGURE 4 MAKING THE CALIBRATION ADJUSTMENT

Replace the clean components by following a reverse procedure. Be sure that the inlet float stop is placed over the range orifice before the meter tube is installed and that the backing on the tube is toward the rear. The "O" ring that goes on the return flow fitting is a friction drive to turn the scale tube; do not lubricate with other than water to permit entry into the tube. All other "O" rings should be lubricated with silicone grease.

### II. Cleaning Operator Protection Shield

Clean shield with kerosene (if required) followed by a cleaning with a solution of soap or detergent and water. Rinse well with clean water and dry with a soft cloth.

#### CAUTION

Do not clean protective shield with cleaners containing strong mineral acids or organic solvents such as ketones, chlorinated hydrocarbons and aromatics or the protective and optical qualities of the shield may be impaired.

### III. Cleaning the Range Orifice

The range orifice may be removed and cleaned while the pipe line is pressurized. Proceed as follows:

1) Remove the meter tubes as discussed in Part I preceding.

2) Using a 1/4" open end wrench, loosen and remove the threaded range orifice. Clean the orifice with a wood or plastic tooth pick so as not to damage the orifice.

**WARNING**

Do not perform the following step if the pipe line contains other than plain water. Liquid spray could come in contact with the operator causing operator injury or other damage.

3) Flush the impact tube while the range orifice is removed. To do this, push in the reading knob, allowing the liquid to flow. Provide suitable protection against liquid spray — a bucket could be inverted over the meter or a rag held loosely around the meter orifice area.

Re-assembly in reverse order.

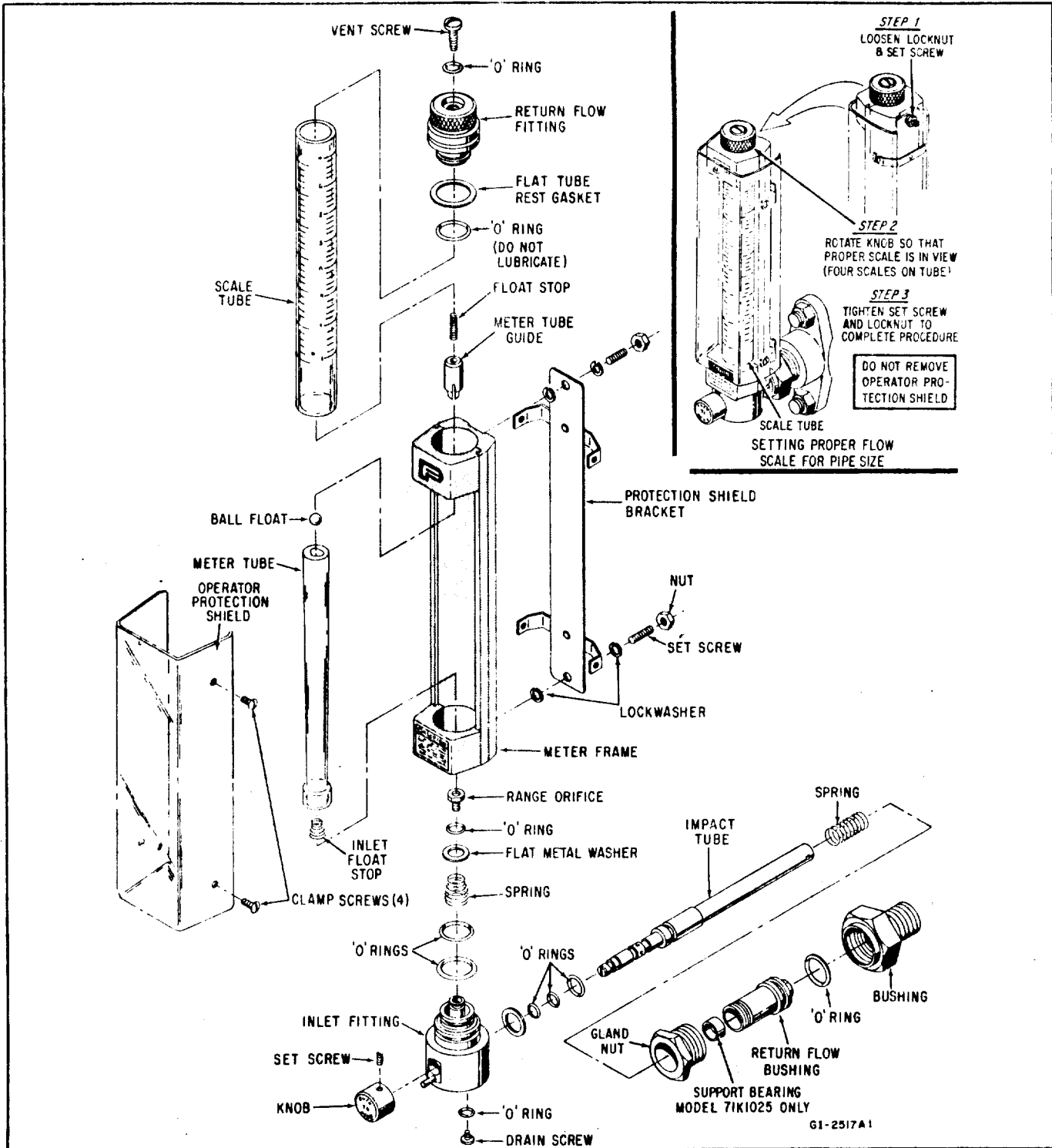

FIGURE 5 EXPLODED VIEW OF FLOW INDICATOR

**FISCHER & PORTER**

WARMINSTER, PENNSYLVANIA 18974

Pub. No. 23470a

# PARTS LIST

for

## SERIES 71K1020 FLOW INDICATORS

Design Level C

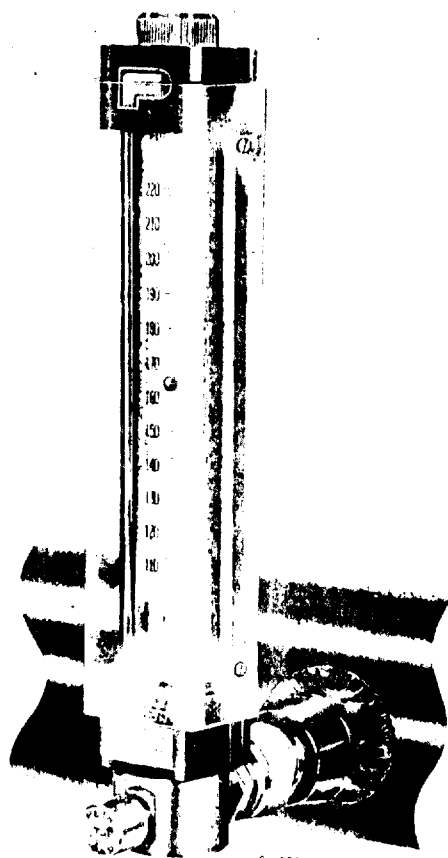

Bushing Mounted

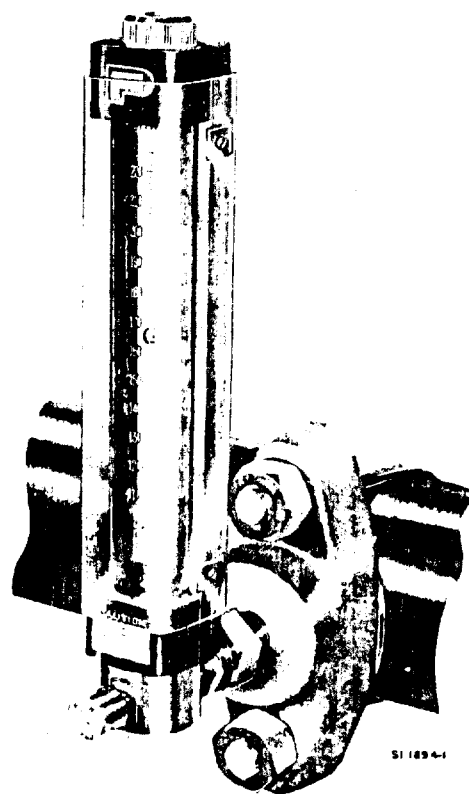

Service Clamp Mounted

FISCHER  
& PORTER **F**



# PARTS LIST

## SERIES 71K1020 FLOW INDICATORS

AVAIL. CODE	KEY	PART DESCRIPTION	PART NUMBER	QUANTITY
	1	FRAME, Meter	609B010A22	1
	2	BRACKET, Protection Shield	623B152U02	1
+	3	TUBE, Scale: Model 71K1021	621A179U01	1
+		Model 71K1022	621A180U01	1
+		Model 71K1025	621A181U01	1
+	4	TUBE, Meter	300D004G10	1
+	5	SHIELD, Operator Protection	351C163U01	1
+	6	KNOB	411A103A12	1
+	7	FITTING, Inlet	601B010B11	1
+	8	TUBE, Impact: Model 71K1021	668A341B11	1
+		Model 71K1022	668A342B11	1
+		Model 71K1025	668A340B11	1
+	9	NUT, Gland	397D135B11	1
+	10	BUSHING, Return Flow: Model 71K1025	371B153U01	1
		Other Models	371B153U02	
+	11	"O" RING, 3/4" OD	101A904U01	1
+	12	BUSHING	364E053B11	1
+	13	SPRING	424A259V91	1
+	14	"O" RING, 7/16" OD	101A706U01	1
+	15	"O" RING, 5/16" OD	101A703U01	2
+	16	GASKET	333C487C12	1
+	17	SCREW, Drain	006M003T10	1
+	18	"O" RING, 5/16" OD	101A703U01	1
+	19	SPRING	424A297V91	1
+	20	WASHER, Flat Metal	377A276T30	1
+	21	"O" RING	101A705U01	1
+	22	ORIFICE, Range: Design Level A	645A118T12	1
+		Design Level B & C	645A202U01	1
+	23	LOCKWASHER: #10	085D010T10	4
+	24	SCREW, Set: #10-32 x 9/16"	019L009S31	2
+	25	NUT, Hex: #10-32	080L200T10	2
+	26	GUIDE, Meter Tube	368H072P30	1
+	27	STOP, Float	304B049T12	1
+	28	"O" RING, 3/4" OD	101A904U01	1
+	29	GASKET, Flat Tube Rest	333C471Q20	1
+	30	FITTING, Return Flow	378B046B11	1
+	31	"O" RING, 5/16" OD	101A703U01	1
+	32	SCREW, Vent	396A013T30	1
	33	MONOGRAM	338A034A30	1
+	34	FLOAT, Ball: Design Level A	303F015G42	1
+		Design Level B & C	303F016G41	1
	35	SCREW, Clamp: #8-32 x 3/16"	090K011U16	4
	36	TAG, Caution	338E335U01	1
	37	STOP, Inlet Float	304B038T12	1
+	38	"O" RING, 3/4" OD	101A904U01	1
+	39	"O" RING, 13/16" OD	101A712U01	1
	40	SCREW, Set: #5-40 x 3/16"	019G003S31	1
	41	TAG, Push To Read	338D224A30	1
	42	NAMEPLATE, Identification (Blank)	338B461A30	1
	43	BEARING, Support: Model 71K1025 Only	369A040R22	1
+	44	KIT, Conversion: Not Shown	614B542U01	1

REF.: 800A655

AVAILABILITY CODE  
(IMMEDIATE AVAILABILITY)

+ PARTS MAINTAINED IN COMPONENTS DIVISION STOCK.

# PARTS LIST

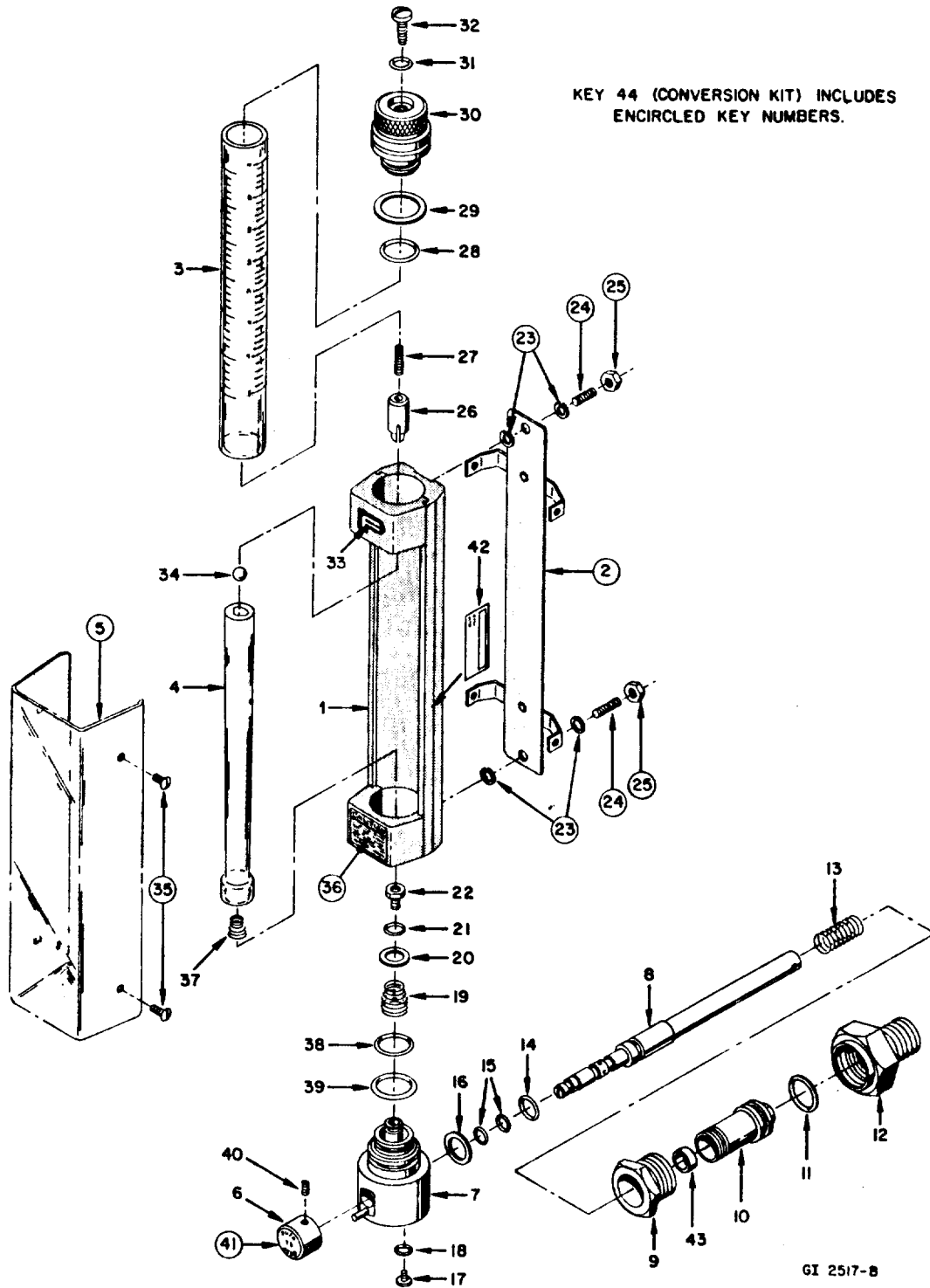

### IMPORTANT

When ordering spare parts please refer to the Fischer & Porter serial and model number referenced on the instrument data tag.

# PARTS LIST

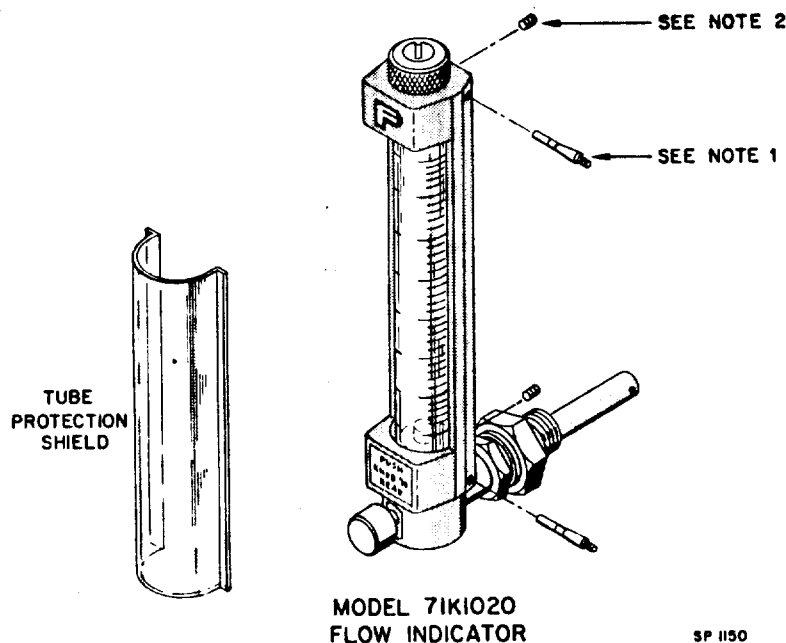

- NOTE 1.** Original design Model 71K1020 Flow Indicators included a tube protection shield with taper pins used to secure the end fittings. It is not practical to retrofit original design Flow Indicators to Design Level C. Also, part numbers for Keys 1, 7 and 30 listed on page 2 are applicable only to the modified design (with set screws) and Design Level C.
- NOTE 2.** Modified design Model 71K1020 Flow Indicators included a tube protection shield with set screws used to secure the end fittings. Modified design Flow Indicators may be retrofitted to Design Level C by using a conversion kit. Order Key 44 from page 2. The kit is recommended by Fischer & Porter Co. and includes operator protection shield parts and instructions.





# PARTS LIST

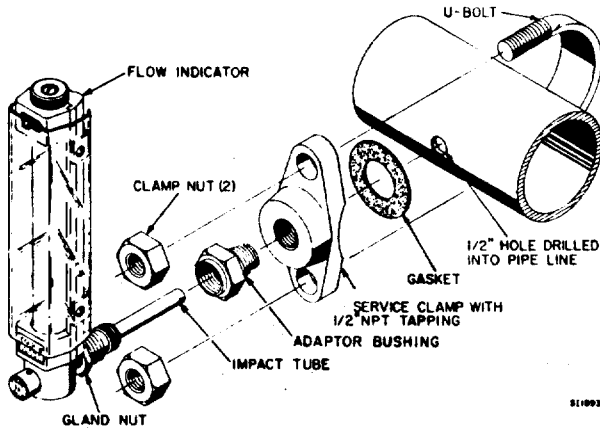

SI 8993-3

## SERVICE CLAMP

AVAIL. CODE	PIPE SIZE	PART NUMBER
+	1-1/2"	108B064U01
+	2"	108B065U01
+	2-1/2"	108B066U01
+	3"	108B067U01
+	4"	108B068U01
+	5"	108B069U01
+	6"	108B070U01
+	8"	108B071U01

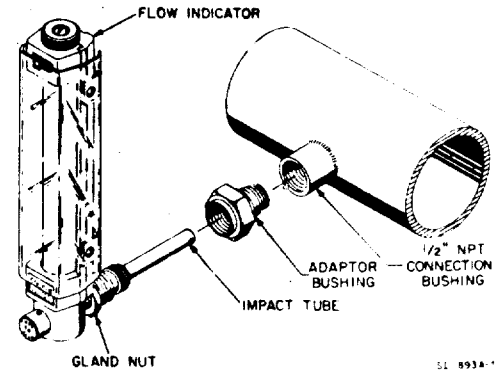

SI 8933A

## PIPE BUSHING

AVAIL. CODE	PIPE SIZE	PART NUMBER
+	2"	112A354U02
+	2-1/2"	112A354U02
+	3"	112A354U01
+	4"	112A354U01
+	5"	112A354U01
+	6"	112A354U01
+	8"	112A354U01
+	10"	112A354U03
+	12"	112A354U03
+	14"	112A354U03
+	16"	112A354U03

AVAILABILITY CODE  
(IMMEDIATE AVAILABILITY)

+ PARTS MAINTAINED IN COMPONENTS DIVISION STOCK.

SP 1151

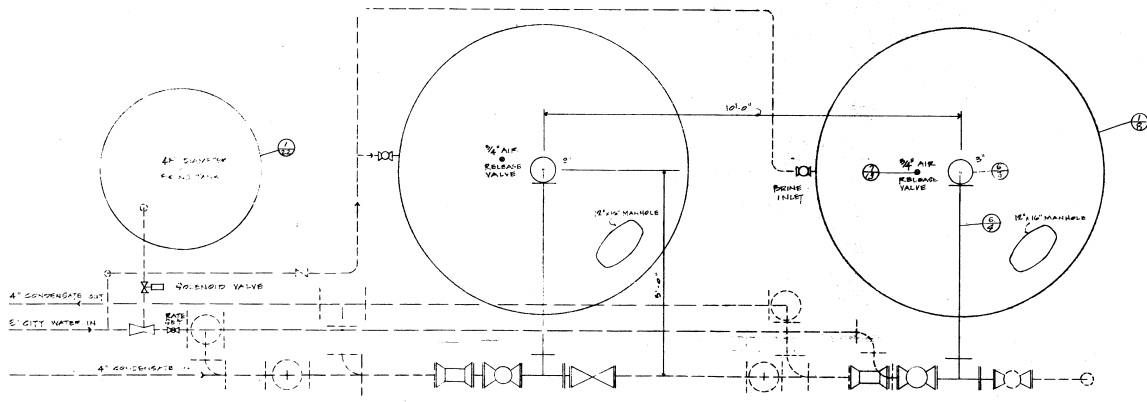

PLAN VIEW

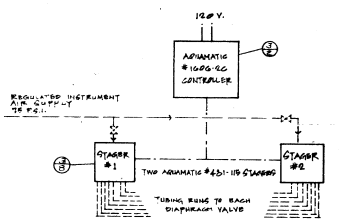

AUTOMATIC VALVE CONTROL SCHEMATIC

LEGEND  
 --- AIR  
 --- ELECTRICAL

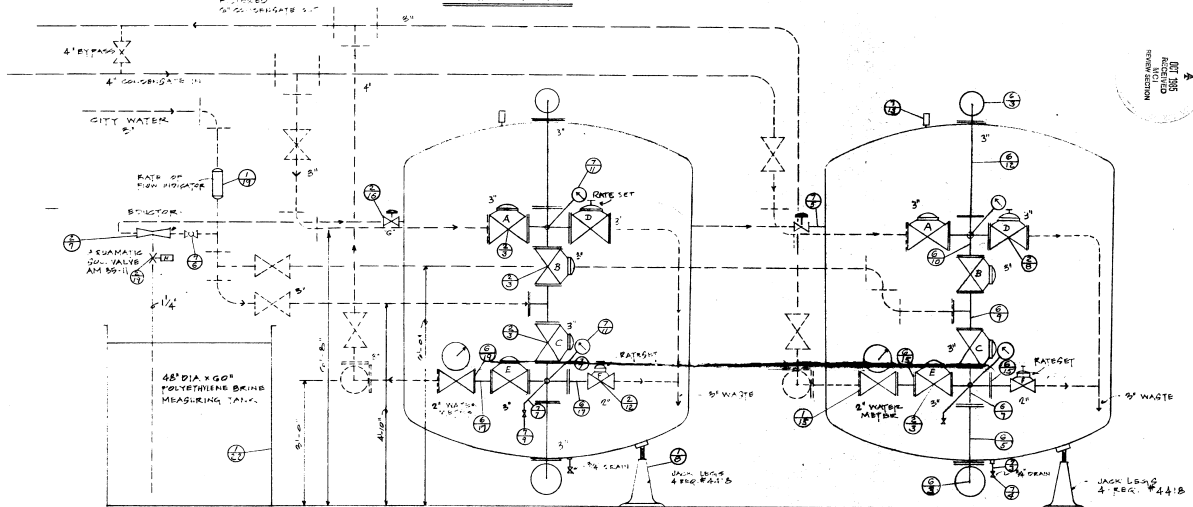

ELEVATION

- NOTES:
1. ALL PIPING, VALVES, TUBING, CONDUIT AND WIRING SHOWN DOTTED BY THE INSTALLER.
  2. PRESSURE VESSELS TO BE 100 P.S.I. ASME CODE.
  3. PRESSURE VESSELS TO BE SAND-BLASTED INTERNALLY AND LINED WITH 2 COATS PLASTIC # 710 (10-10 MILS). EXTERIOR TO BE SAND-BLASTED AND PRIMED.
  4. FOR INTERNAL DETAILS, SEE DRAWING # 94 B - 2.
  5. DRILL AND TAP 3/4\"/>

THESE PRINTS APPLY ONLY TO 48\"/>

POTOMAC WATER & WASTE SYSTEMS, INC.  
 202 WHEATON PLAZA BLDG, NORTH  
 WHEATON, MARYLAND 20852

C.I.A., LANGLEY, VA.

SCALE 3/4\"/>	APPR. BY RO	DRAWN BY ADNAB
DATE 1-25-65		REVISED 8/22/65
2-54\"/>		DRAWING NUMBER 94 B - 1P REVISED 1

**SECT. A-A**

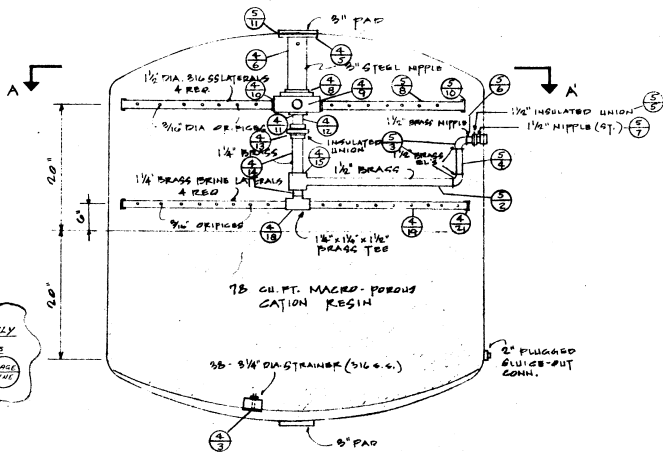
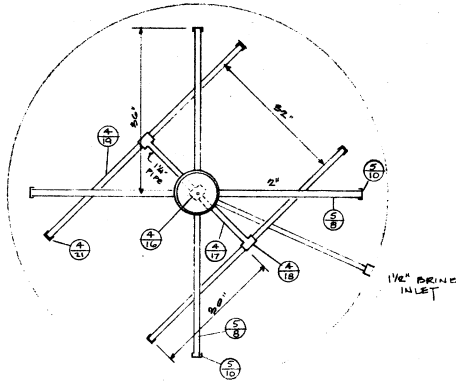

**ELEVATION**

THESE PRINTS ALTERED ONLY  
TO SHOW PAGE & LINE NO.'S  
OF BILL OF MATERIALS



NOTE:  
FOR ORIENTATION OF  
BRINE INLET, SEE  
TANK DETAIL  
PWG. 948-S

<b>POTOMAC WATER &amp; WASTE SYSTEMS, INC.</b>		
202 WHEATON PLAZA BLDG, NORTH WHEATON, MARYLAND 20902		
C.I.A., LANGLEY, VA.		
SCALE N.T.S.	APPR. BY JLB	DRAWN BY JLB
DATE 3-22-55	REVIS	REVIS
INTERNAL DETAILS 84" DIA. SOFTENER		DRAWING NO. 948-2P