

# ESH/V

## Installation Instructions

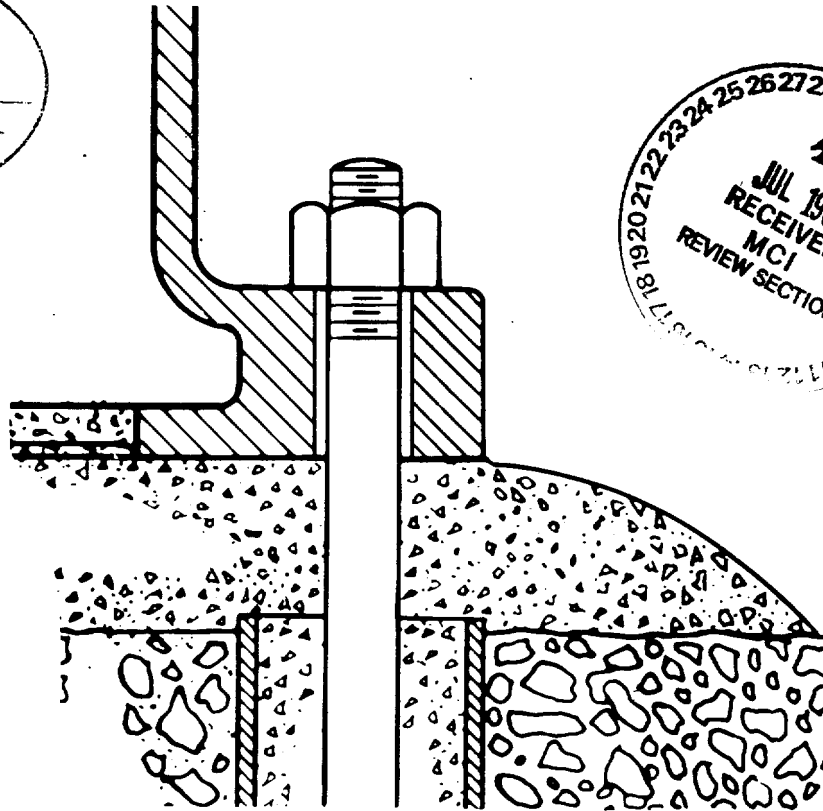
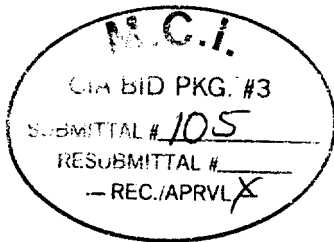

**INGERSOLL-RAND®**  
**AIR COMPRESSORS**

Form AP 0250-C  
September 1977  
Supercedes AP-0250 B

## **PREFACE**

This Manual is being forwarded to assist the new ESH/ESV owner in the successful installation prior to start-up of his machine and to acquaint him with some of its features. This manual should be studied thoroughly before the arrival of the machine. This manual covers general information applying to all sizes of ESH/ESV Compressors. Additional material in the form of drawings and an instruction book with material applying specifically to your machine will be forwarded later.

Should you have any questions concerning this book or the equipment furnished, contact your nearest Ingersoll-Rand Representative.

This manual has been prepared by Ingersoll-Rand, Air Power Compressor Division, Technical Publications, Department Painted Post, New York 14870

©Copyright Ingersoll-Rand Company 1976

# CONTENTS

## SECTION I – AIR SYSTEM PREINSTALLATION

Product Description . . . . .	5
Receiving . . . . .	5
Handling . . . . .	5
Storage . . . . .	5
Location and System Layout . . . . .	5

## SECTION II – FOUNDATION AND MOUNTING

General . . . . .	7
Foundation Building . . . . .	7
Setting the Compressor . . . . .	9
Grouting . . . . .	10
Foundation Finishing . . . . .	11

## SECTION III – AIR SYSTEM INSTALLATION

Pipe Cleaning . . . . .	13
Inlet Piping . . . . .	13
Discharge Piping . . . . .	15
Cooling Water . . . . .	16
V-Belt . . . . .	16

## SECTION IV – GENERAL INFORMATION

Compressor Accessories . . . . .	17
Package Unit Installation . . . . .	17
Typical Air Piping Schematic for Single Stage Compressor . . . . .	18
Typical Air Piping Schematic for Two Stage Compressor . . . . .	19

## **SAFETY PRECAUTIONS**

READ CAREFULLY BEFORE INSTALLING THE COMPRESSOR.

### **COMPRESSED AIR AND ELECTRICITY CAN BE DANGEROUS**

BEFORE DOING ANY WORK INVOLVING MAINTENANCE, OR ADJUSTMENT - BE SURE THE ELECTRICAL SUPPLY HAS BEEN DISCONNECTED, AND THE COMPRESSOR'S ENTIRE SYSTEM HAS BEEN VENTED OF ALL PRESSURE.

WHERE LUBRICATING OIL IS PRESENT IN COMPRESSOR DISCHARGE, AN AFTERCOOLER SHOULD BE INSTALLED IN THE FINAL COMPRESSOR DISCHARGE LINE MOUNTED AS CLOSE AS POSSIBLE TO THE COMPRESSOR.

A PRESSURE RELIEF VALVE MUST BE INSTALLED IN THE DISCHARGE PIPING BETWEEN THE COMPRESSOR AND ANY POSSIBLE RESTRICTION, SUCH AS BLOCK VALVE, CHECK VALVE, AFTERCOOLER, OR AIR DRYER. FAILURE TO INSTALL A PRESSURE RELIEF VALVE COULD RESULT IN OVERPRESSURE, PIPE RUPTURE, DAMAGE TO COMPRESSOR AND PERSONAL INJURY. REFER TO THE INSTRUCTIONS BOOK FOR SPECIFIC INFORMATION.

ON BELT DRIVEN COMPRESSORS, A BELT GUARD, CONFORMING TO O.S.H.A., STATE AND/OR LOCAL STANDARDS/CODES SHALL BE INSTALLED BY THE USER.

THOSE RESPONSIBLE FOR INSTALLATION OF THIS EQUIPMENT MUST PROVIDE SUITABLE GROUNDS, MAINTENANCE CLEARANCE AND LIGHTNING ARRESTORS FOR ALL ELECTRICAL COMPONENTS AS STIPULATED IN O.S.H.A. 1910.308 THROUGH 1910.329.

WHEN A RECEIVER IS INSTALLED, IT IS RECOMMENDED THAT OCCUPATIONAL SAFETY AND HEALTH STANDARDS AS COVERED IN THE FEDERAL REGISTER, VOLUME 36 NUMBER 105 PART II PARAGRAPH 1910.169 BE ADHERED TO IN THE INSTALLATION AND MAINTENANCE OF THIS RECEIVER.

BEFORE STARTING THE COMPRESSOR, ITS MAINTENANCE INSTRUCTIONS SHOULD BE THOROUGHLY READ AND UNDERSTOOD.

FAILURE TO HEED THIS WARNING MAY RESULT IN AN ACCIDENT CAUSING PERSONAL INJURY OR PROPERTY DAMAGE.

# SECTION I

## AIR SYSTEM PREINSTALLATION

### PRODUCT DESCRIPTION

The Ingersoll-Rand ESH (Horizontal) and ESV (Vertical) Compressors are straight-line, single stage, double acting, water cooled, heavy duty, crosshead type units in the 15 to 125 horsepower range. Both ESH and ESV Compressors are available with either Lubricated or Non-Lubricated cylinders. Multi-Stage and Vacuum Pump units are also available.

The rugged design of the ESH-ESV incorporates such features as "A" Channel Valves, Full Floating Aluminum Alloy Bearings, Filtered Pressure Lubrication, and Sealed Frame. All running gear parts are precision made and adjustment free. The sealed frame prevents contamination and waste of lube oil and due to low frame oil temperatures, oil changes are infrequent. The cylinder and heads are water jacketed for efficient cooling. Easy access to wiper rings and cylinder packing is gained through removal of bolted, sealed covers in the distance piece.

ESH-ESV Compressors require only a simple mounting with easy hook-up. These units are more compact than other compressors of their type and the ESV is especially suitable where floor space is tight. ESV Packaged Plants are also available.

### RECEIVING

For shipment the compressor has been adequately packed. Immediately upon receiving, the unit should be carefully inspected. If shipping damage is noticed it should be reported to the carrier immediately. Generally, the compressor and its standard components are shipped fully assembled. Accessories may be shipped separately and assembly will be required. Packaged Plants will be fully assembled and required only placement and hook-up of water and air lines.

### HANDLING

The wood packing skid used for most domestic shipping of bare units is designed for fork lift truck use. Packaged units are assembled on a permanent steel skid and may be handled in the same manner.

### STORAGE

**General**—Both Lubricated and Non-Lubricated units have been prepared at the factory with an anti-corrosive material to retard rust and deterioration during shipment. While this preparation is adequate for shipment and short-term storage in a warm, dry environment; it will not sufficiently protect the unit for any extended period. If

there is to be a delay in erection and putting into service, special precautions may be necessary. Your nearest Ingersoll-Rand Distributor or representative should be contacted.

**Non-Lubricated Compressors**—Upon inspection, it may be noted that the cylinder is protected by Vapor Phase Inhibitor (VPI) Crystals. Though similar to a light, colored sand in appearance; VPI is non-abrasive and will vaporize when the machine is started.

If after receiving, it is noticed that the protective seals are damaged and/or covers opened, or if after use the unit is to be stored, shipped, or otherwise inoperative; your local Ingersoll-Rand Representative should be contacted for proper reprocessing procedures.

### LOCATION AND SYSTEM LAYOUT

It is recommended that the unit be located in an enclosed building. In cold climates the area should be heated. The location should be well ventilated, lighted, and most importantly, clean and free of dampness, and corrosive vapors. A crane or hoist is helpful for both erection and maintenance and should be provided when machine parts are heavy. Enough room should be left around the compressor to allow for maintenance.

The dimensions given on the general arrangement drawing for removal of pistons and rods are based on the normal amount of dismantling. The space required can usually be reduced by further dismantling should floor space be limited. Contact your nearest Ingersoll-Rand Branch Office or Distributor for further information.

When selecting a location, equal consideration must be given to the physical needs of both the compressor and its system's components. The final location will be influenced by the continuing cost of operating supervision at that point. An automatic control system may make possible the use of an area which otherwise might require costly supervision. Positive outside ventilation is recommended for any area where ambient temperature may exceed 104°F (40°C). A good water supply and drainage will be required by both the compressor cylinder and an aftercooler. The air compressor plant should always include an aftercooler/separator, followed by a receiver. As compressed air within the system cools substantial amounts of water vapor entering the system will condense. Therefore, the aftercooler/separator, receiver, and various points within the distribution system must be kept drained. The use of automatic traps is usually the best method. When dry air is mandatory or maximum efficiency is required at the

point of usage serious consideration should be given to the use of an air dryer.

Matched components in any system are important for efficient performance. For highest efficiency and lowest

overall cost per cubic foot of air you need an air power system that is properly engineered. The following standard components are available for your system:

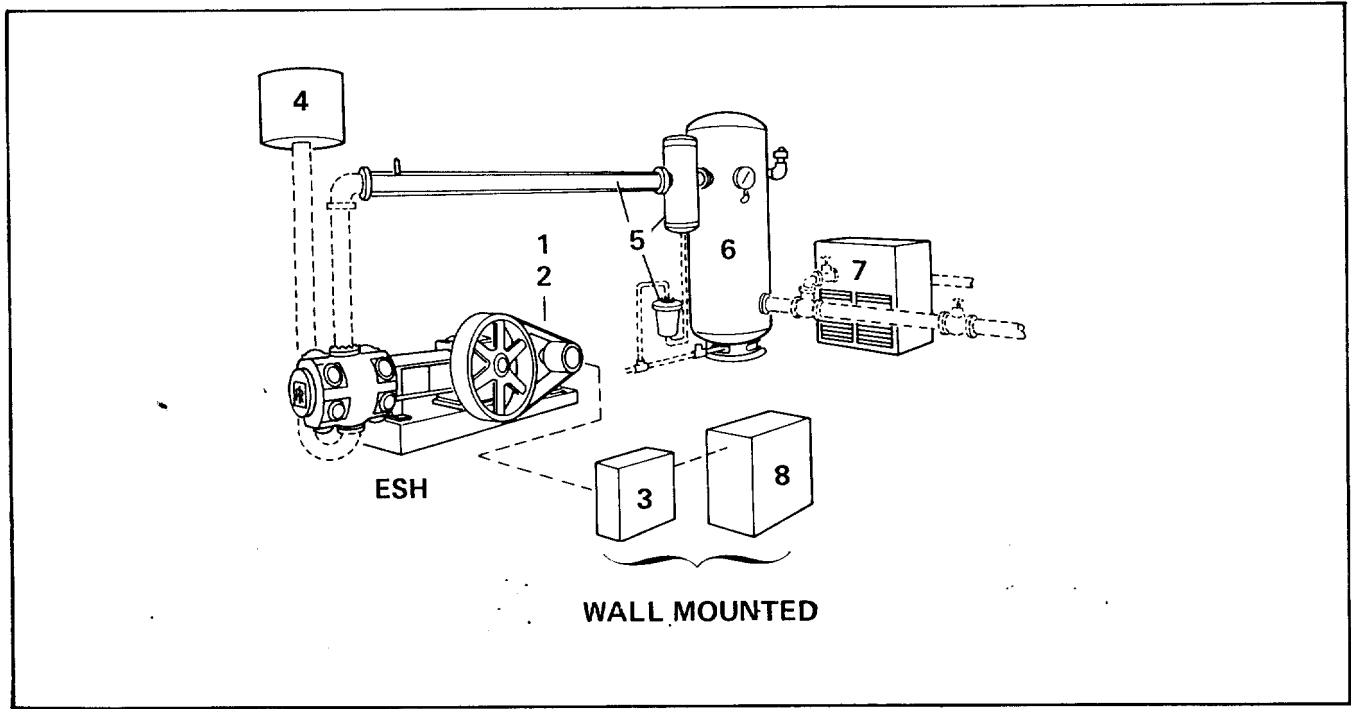

Figure 1. Standard System Components

1. Ingersoll-Rand slide base.
2. Motor - Standard T-Frame, nema design.
3. Motor starter - Standard - Full voltage magnetic across-the line starter.
4. Inlet filter silencer - Purpose of this filter is to prevent harmful particles from entering the compressor cylinder and minimize noise.
5. Aftercooler - Purpose is to cool the compressed air after the final compression stage. It is also recommended that a moisture separator and condensate trap be furnished.
6. Receiver - Manufactured to ASME codes. Standard fittings include inspection opening, safety valve, pressure gauge. A receiver is recommended to efficiently control load cycle and minimize air piping pulsation. An automatic condensate trap is recommended.
7. Air Dryer - In a fully-enclosed cabinet with temperature switch and moisture separator. Purpose is to reduce cost of instrumentation failure, piping corrosion, maintenance traps and drains due to water and oil compressed air supply lines.
8. Control System - To regulate the operation of the compressor to the customers fullest advantage.
9. Belt Guards - (Fully enclosed) is used to cover the rotating sheaves and v-belts and is recommended as a means of preventing persons or objects from coming in contact with these moving parts of the compressor.

For additional information refer to the air flow diagrams in Section 4.

## SECTION II

# FOUNDATION AND MOUNTING

### GENERAL

Since the responsibility for a successful foundation rests with the customer, he should carefully check the following points which are suggested in the interest of securing a satisfactory installation:

The foundation drawing furnished shows the minimum size recommended for hard, firm ground such as well cemented sand and gravel or hard clay, always dry. If the soil is wet or less firm, solid boring or deflection test should be made to determine whether to increase the foundation size.

Alluvial solid, unconfined sand or gravel, soft clay, silt or filled ground do not furnish satisfactory support for foundation of large reciprocating machines. When these soils are encountered, the foundation should be extended or placed on a reinforced mat so as to increase the total mass, provide a large surface in contact with the ground and reduce the soil bearing pressure.

Foundations for reciprocating machines differ from foundations for buildings or similar structures since dynamic rather than static loads are involved. Consequently much lower solid bearing pressure should be used than permitted by municipal ordinances; usually 1/4 to 1/6 in (6.4 to 4.2 mm). Low soil bearing pressures keep the natural frequency of the foundation high and prevent resonance, also reduce the possibility of transmitted vibration.

When the soil is soft, piling may be necessary to provide vertical support and to compact the sub-soil. In some cases spur or batter piles are desirable to absorb horizontal forces.

If necessary to make the foundation deeper than shown in the foundation drawing, the area of the base should be increased. Likewise when it is necessary to set the machine higher above the floor level than shown on the foundation drawing, or where the soil is not tamped back around the sides of the foundation, the area of the base of the foundation must be increased to compensate. This is especially important if the soil is not the very best, as failure to provide an adequate base will promote rocking.

When several units are installed, they should either be placed on a common foundation, or, if separate foundation blocks are desired, they should be joined by a mat of adequate thickness. The mat thickness will vary from 18" (457 mm) minimum to 36" (914 mm) or more, depending on the ground characteristics, the size of machine, and the spacing between the machines.

Frequently it is possible to observe neighboring installations on similar soil. Such observations will greatly aid in determining whether or not additional soil contact area, additional mass or piling will be required.

When conditions are at all doubtful or if the foundation site is located where transmitted vibration might be objectionable, a foundation specialist should be consulted. The Ingersoll-Rand Company is prepared to supply information on the unbalanced forces for the use of the specialist in analyzing the problem.

THE FOUNDATION IS A POOR PLACE TO ECONOMIZE. THE EXTRA COST FOR AN ADEQUATE FOUNDATION IS USUALLY SMALL, AND IS ALWAYS WELL JUSTIFIED.

### FOUNDATION BUILDING

The following instructions apply not only to frame grouted compressors but also to sub-base grouted compressors. Reference is given to frame grouted compressors, and if there is any variation in the sub-base terminology, it will follow immediately in parentheses ( ).

#### 1. Template (See Figure 2.)

- a. Build a firmly supported wooden template so that the foundation can be built below it. This template should be made in one piece to include compressor frame bolts, motor bolts, and distance piece bolting, where applicable. (In the case of a package unit, the template will be made to the sub-base dimensions.)
- b. Locate the template in the exact position to be occupied by the compressor. The bottom of the template should be level and approximately 3/4" (19 mm) lower than the desired height of the compressor bed-plated or (subbase).

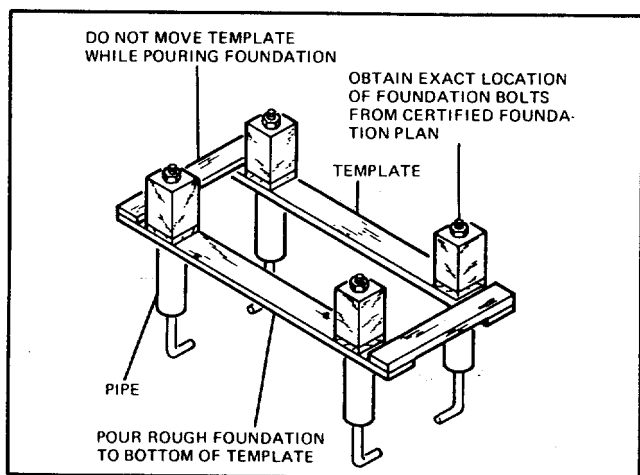

Figure 2. Template Used for Locating Foundation Bolts

#### 2. Foundation Bolting (See Figure 3.)

- a. Slip a 1-1/2" (38 mm) minimum diameter pipe over each foundation bolt and hang the bolts from the tem-

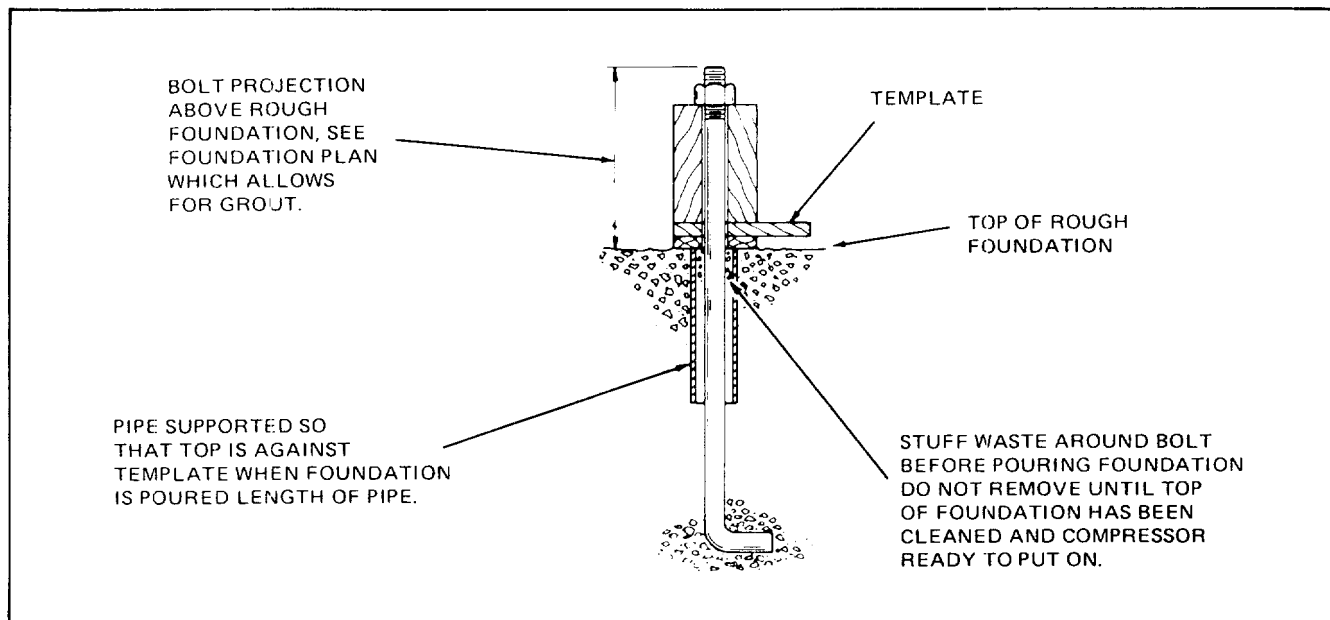

Figure 3. Method Used for Installing Foundation Bolts

plate. This pipe is used to correct any variation in bolting and should be long enough to extend from the template to within a few inches of the bottom of the bolts.

- b. To insure proper height of the bolts above the frame (sub-base), place blocks of wood on top of the template board to make the thickness of the template equal to the thickness of the compressor flange (sub-base). See foundation plan for this dimension. The top of the foundation bolts will then be the required distance above the frame (sub-base) holes. Screw down the foundation bolt nuts so that the bolts project above the nuts, see foundation plan for dimensions.
- c. Place waste around top of the foundation bolts to prevent concrete from falling into the pipe while pouring.
- d. By means of wire, fasten the pipe in position so that its upper end is against the bottom of the template.

NOTE: Foundation bolts for these compressors usually have a small right-angle bend at their lower end to prevent them from turning when the nut is pulled down.

### 3. Alternative Foundation Bolting (See Figure 4.)

To mount the compressor to an existing foundation the concrete must be of an equivalent mass to that on the foundation plan and comply with sub-soil requirements. To fasten the compressor base to the existing foundation a

non-shrinking or epoxy type cement should be used with the following procedure.

NOTE: It should be pointed out that an existing foundation which is oil soaked should not be used. Foundation bolts cannot be sufficiently bonded in oil soaked concrete.

- a. To locate the hold down bolts, set the compressor in the desired location and mark or scribe the bolt's locations.
- b. Remove the compressor and drill 2 inch (51 mm) diameter holes at least 6 inches (152 mm) deep. When the hole is drilled to the desired depth, tip and rotate the drill in such a manner to widen the bottom of the hole. Avoid drilling through the concrete. If the bottom breaks out of the hole it must be plugged to prevent wasting of cement.
- c. Blow all loose particles from the holes and thoroughly wet the hole's surface. Blow out any excess water.
- d. Lift the compressor and place the hold down bolts in its base with about 1/8 inch (3.2 mm) of bolt projecting above the nut. Set the compressor in place with the bolts hanging in the holes (see Figure 4).
- e. Level the compressor using metal wedges or plates to provide approximately 3/4 inch (19 mm) of grout between it and the foundation. Remove the com-



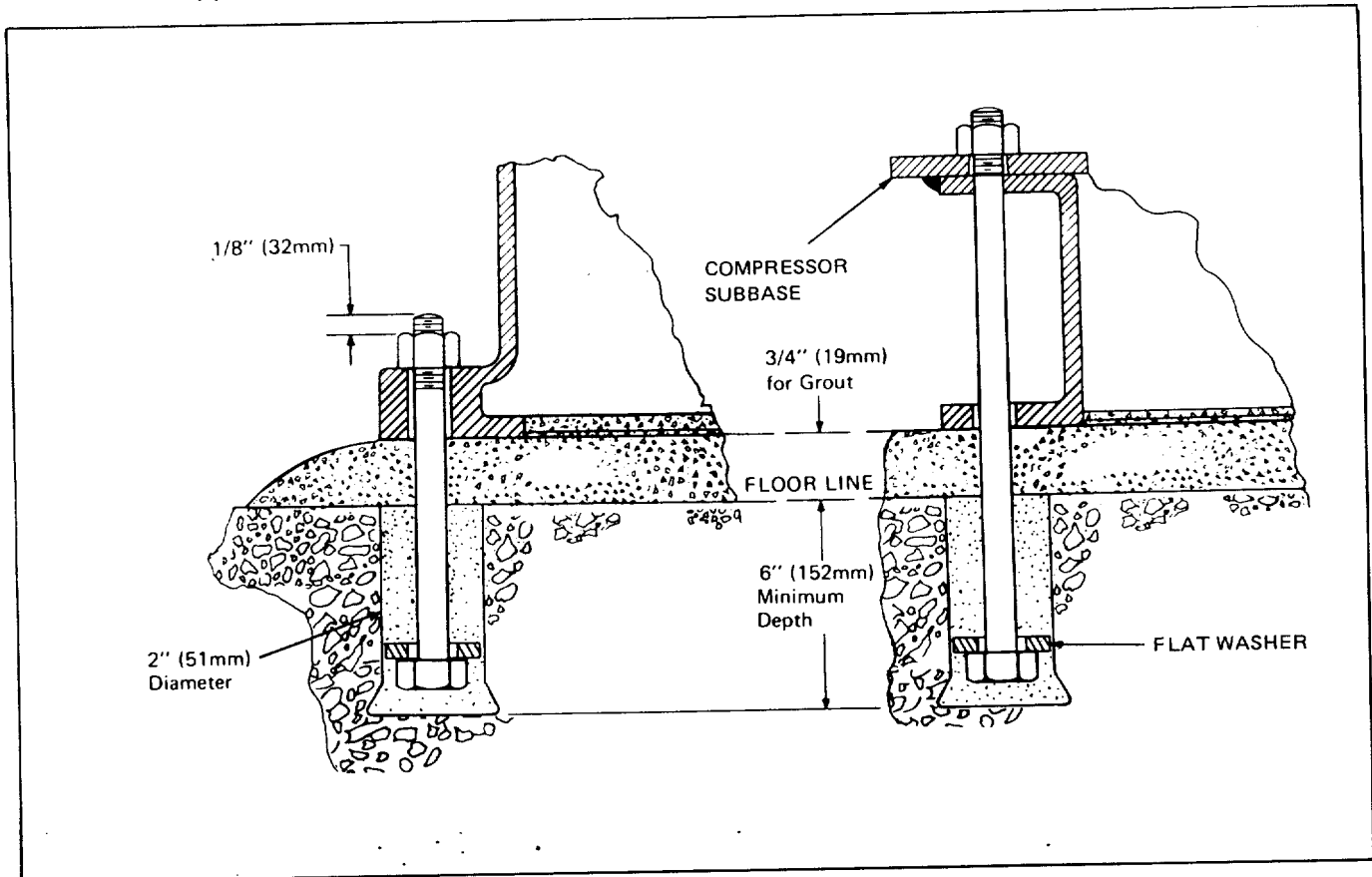

Figure 4. Alternate Foundation Bolting

pressor frame top cover and place a level on the finished surface for leveling in both directions.

- f. Mix a small quantity of the non-shrink or epoxy type cement to pouring consistence. Carefully follow the mixing instructions on the package. Thoroughly mix the cement and pour it into the holes, filling them flush to the floor. Most cements of this type set quickly and care should be taken not to mix more than can be used within a given period.

- g. Generally the compressor can be grouted an hour after the cement has set (see grouting instructions on Page 10). However, it is best to follow the package instructions for setting and hardening time. The mounting bolts should not be tightened until the cement and grout have thoroughly hardened.

#### 4. Foundation Mixture

Concrete—A good strength mixture for the foundation consists of:

Cement	1 part
Sand (clean & sharp)	2 parts
Crushed Stone or Gravel	4 parts

#### 5. Pouring the Foundation

- Check the location and height of all foundation bolts before pouring your foundation.
- Pour concrete to bottom of template and leave top surface rough to accommodate grout.
- Cover the foundation with burlap and wet it down twice a day until forms are removed at the end of the third or fourth day.

There should be a total elapsed time of twenty-one days between the pouring of the foundation and the starting of the compressor, using the mixture above. If it is desired to reduce this time through the use of a quick drying cement, the cement manufacture should be consulted as to the possible saving.

#### SETTING THE COMPRESSOR

(See Figure 5.)

- Roughen the foundation with a star chisel and thoroughly clean the surface.
- Remove waste from around the foundation bolts.

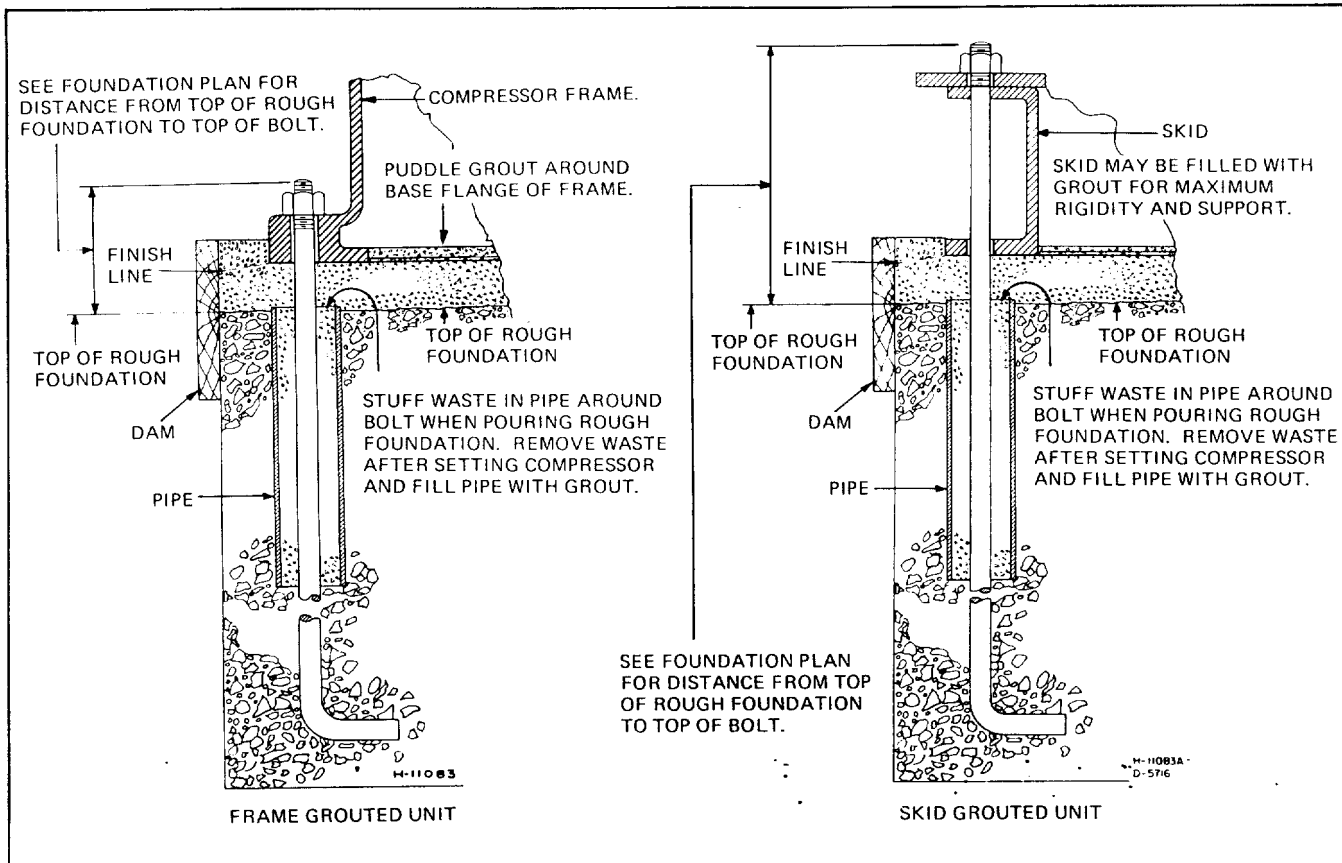

Figure 5. Setting and Grouting of Foundation Bolts

3. Prepare enough metal wedges to allow one to be placed near each foundation bolt. The wedges must be thick enough to allow approximately 3/4" (19 mm) of grout between the bottom of the compressor frame (sub-base) and the top of the foundation when the unit is in its final level position.
4. Wedges should be placed so the bottom of the frame (sub-base) is about 1/4" (6 mm) below its final setting.
5. Drive in the wedge a little at a time and in rotation until the frame (sub-base) is up to the desired height and level in both directions.
6. On skid mounted units loosen all bolts between the compressor frame and its skid. All frame feet should be probed with feelers to assure the frame is sitting flat on the skid. If it is not sitting flat, adjust by driving wedges between the skid and the foundation top until the compressor is flat and uniformly supported by all feet and the top of the skid. The object is to make the unit sit flat on top of the skid. The skid should be completely filled grout to provide firm support and maximum rigidity.
7. When the unit is level, place washers and nuts over the foundation bolts and tighten them down a little at a time in rotation. At the same time, check with the level to make sure the compressor does not shift on the wedges.
8. On frame grouted units check the alignment of the motor sheave with the compressor sheave; they must be parallel. The motor location, with respect to the base, should allow sufficient movement to install and adjust the V-belts.

**GROUTING**

1. A non-shrinking or epoxy type grout is strongly recommended for grouting the compressor frame (sub-base) to the foundation. In either case it is important that the manufacturer's instructions be followed. In the event that non-shrinking grout is not available, prepare a mixture of two parts clean sharp sand to one part cement, thoroughly mixed with water so that it will just flow freely. Do not use any more water than necessary to avoid excessive shrinkage.

2. Before grouting make a final check on level and alignment or compressor.
3. Build a temporary dam of boards around the top of the foundation about 2" or 3" (50 mm or 76 mm) higher than the bottom of the frame (sub-base). The gout will be carried up under the compressor to the full height of the dam. Mark the location of the wedges so they can be removed after the grout has started to set. Prepare a sufficient amount of grout.
4. Wet the top of the foundation thoroughly, but avoid leaving puddles. Blow any water out of the foundation bolt holes with an air hose. Puddle the grout continuously as it is poured to remove any air pockets. Be sure to work the grout into the holes around the foundation bolts.
5. As soon as the grout has started to set, remove the forms, cut off the grout flush with the bottom edge of the frame (sub-base), trowel smooth and point up the foundation. After the initial set of the grout, (not less than 24 hours), PULL OUT THE ADJUSTING WEDGES AND PATCH. After the grout has thoroughly set, (three or four days), check the foundation bolts to see that they are tight.

#### FOUNDATION FINISHING

(See Figure 6.)

If non-shrinking grout is used, remove the grout down to the foundation on all surfaces that extend beyond the frame. This area should be filled in with regular cement and

grouts, they must not be used in places where they are not sand grout. Because of the expanding ability of non-shrink confined by the frame. Non-shrink grouts will ravel and provide a bad appearance, and will sometimes fail physically when applied to an open area.

After the concrete work is finished, the foundation should be painted with a good water proof and oil proof cement paint, to prevent oil from softing the foundation.

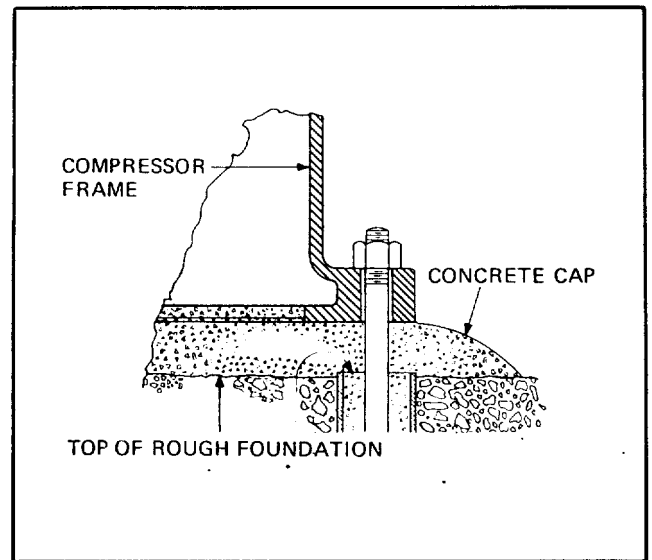

Figure 6. Capping Grout

**NOTES**

## **SECTION III**

# **AIR SYSTEM INSTALLATION**

### **PIPE CLEANING**

Although the use of clean piping is important on any compressor, it is vital in "NL" service. Dirt, scale, welding beads, or any type of foreign matter from piping that has not been properly cleaned will promote wear and failures with resultant expensive shutdowns and replacement of parts. If practical, use a rust resistant material for the piping. If steel piping is desired, pickle and clean. Coat with a rust preventative.

### **INLET PIPING**

**Compressor**—Whenever possible the intake of an air compressor should be piped to the outside of the building where the coolest and cleanest air is available. In certain cases, such as package units, an alternate system may be utilized having the intake filter mounted right at the cylinder.

Where piping is used the following precautions should be followed. Locate the end of the intake pipe so that waste being discharged from pipes near it can not be drawn into the compressor intake. The piping should be well supported and slope away from the compressor cylinder thus preventing any condensation from draining into the cylinder. Moisture in the cylinder will cause accelerated wear of rubbing parts.

### **IMPORTANT**

**Care should be taken to assure that the inlet piping slopes away from the cylinder. Should condensate drain into the cylinder accelerated wear and/or possible damage may occur.**

The size of the intake connection is indicated on the foundation plan. Do not reduce the size intake pipe from that shown on the plan. See the foundation plan for critical lengths to avoid.

### **IMPORTANT**

**CLEAN PIPING CAN NOT BE OVER-EMPHASIZED. Any dirt, rust, welding beads or scale carried into the compressor will cause extensive damage.**

The use of backing-up rings for butt welds in piping is recommended. This will prevent welding beads getting into the piping and causing damage.

Piping should be fabricated with sufficient joints so that it can be dismantled easily for cleaning and testing. It is better to clean and test piping in sections before actual erection than after it is in place. If iron piping is used on the inlet piping we recommend the pipe be pickled. Non-lubricated compressor's inlet pipe should be of non-corrosive material such as aluminum, stainless steel, or plastic.

**Vacuum Pump**—Where a vacuum pump is working on a high vacuum, a very slight leakage either into the pump or into the system makes all the difference between good and poor performance. It is, therefore, very important to take every precaution to eliminate such leakage.

If the vacuum system should contain any dust or other abrasive material, a filter must be installed. Such materials, if carried into the cylinder, will cause rapid wear of the piston and cylinder and will promote the formation of carbon on the valves.

It is equally important to safeguard against moisture being drawn into the cylinder. Moisture will wash away the cylinder lubricant, and if large quantities should accumulate in the intake pipe and be drawn into the cylinder, the non-compressibility of the liquid may cause breakage of parts. For these reasons, give careful attention to the piping layout. Arrange the piping so that moisture will not drain back into the cylinder and provide for draining low spots. Follow the suggestions shown in Figure 7.

**Temporary Line Filter**—When first starting, it is advisable to use a temporary line filter in the intake line near the compressor to catch any dirt, chips, or other foreign material that may have been left in the pipe. But clean the pipe first. Do not depend on a temporary line filter.

Even though the previous cleaning procedure has been carefully followed on the compressor piping, a temporary filter should be installed in the suction line to the suction bottle to remove particles 230 microns (.009 in. [.228 mm]) in diameter or larger. This filter is to be supplied by the customer. If the compressor is a non-lubricated design, the filter should be designed to remove particles 140 microns (.0055 in. [.1397 mm]) in diameter or larger. Provision must be made in the piping to check the pressure drop across the filter and to remove the filter cell for cleaning. If pressure drop across the filter exceeds five percent of the upstream line pressure, remove the filter, clean it thoroughly and re-install. The filter cell should be

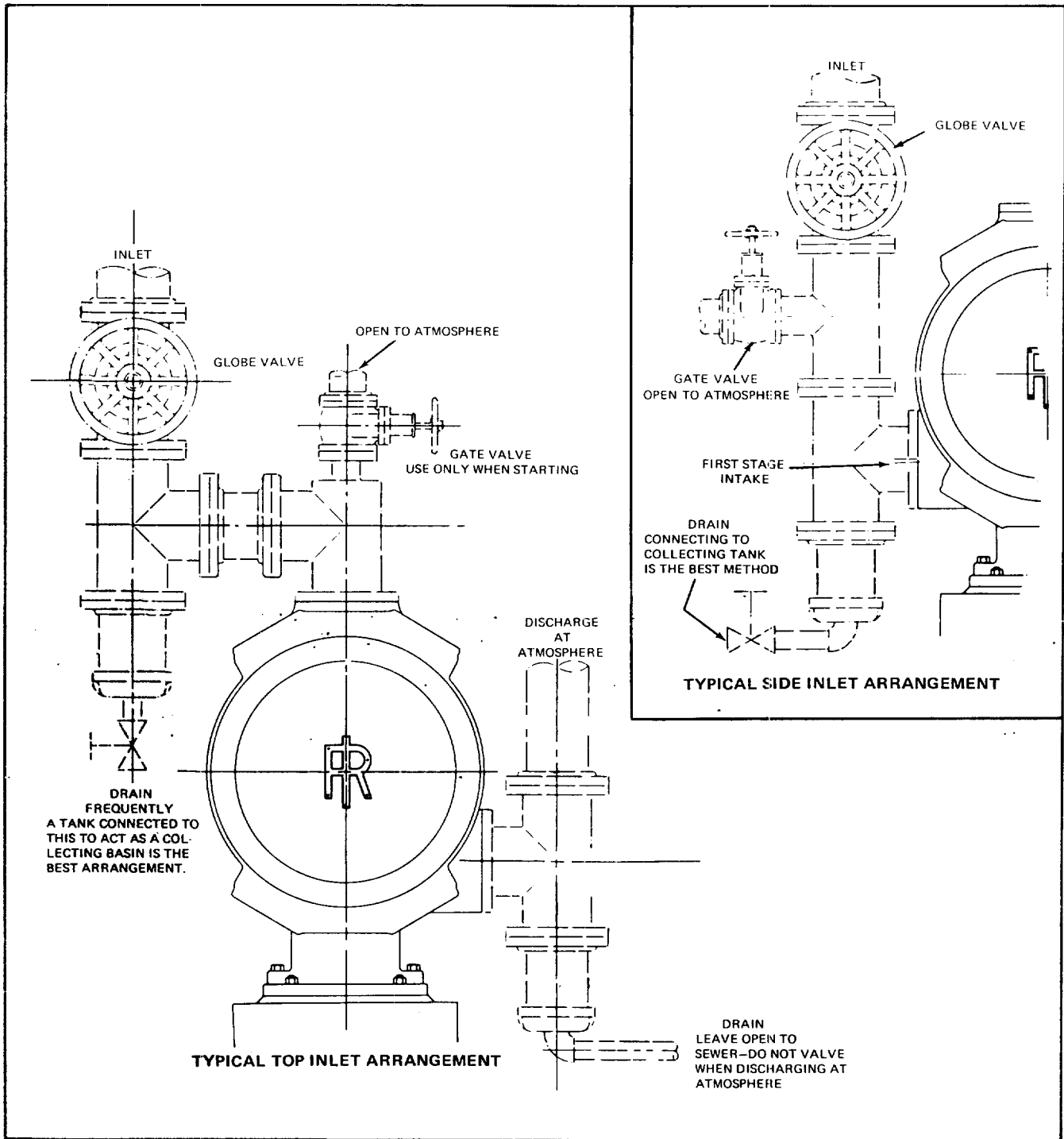

Figure 7. Typical Piping Arrangement - Vacuum Pump

removed and left out only when the inlet line is free of welding beads, pipe scale and other extraneous matter. **THESE FILTERS ARE NOT INTENDED FOR PERMANENT INSTALLATIONS.** A typical installation with pressure drop gauge is illustrated in Figure 8.

We recommend that a cone, screen type filter, as illustrated, be installed in a horizontal run of piping for ease of cleaning out dirt on the upstream side of the filter.

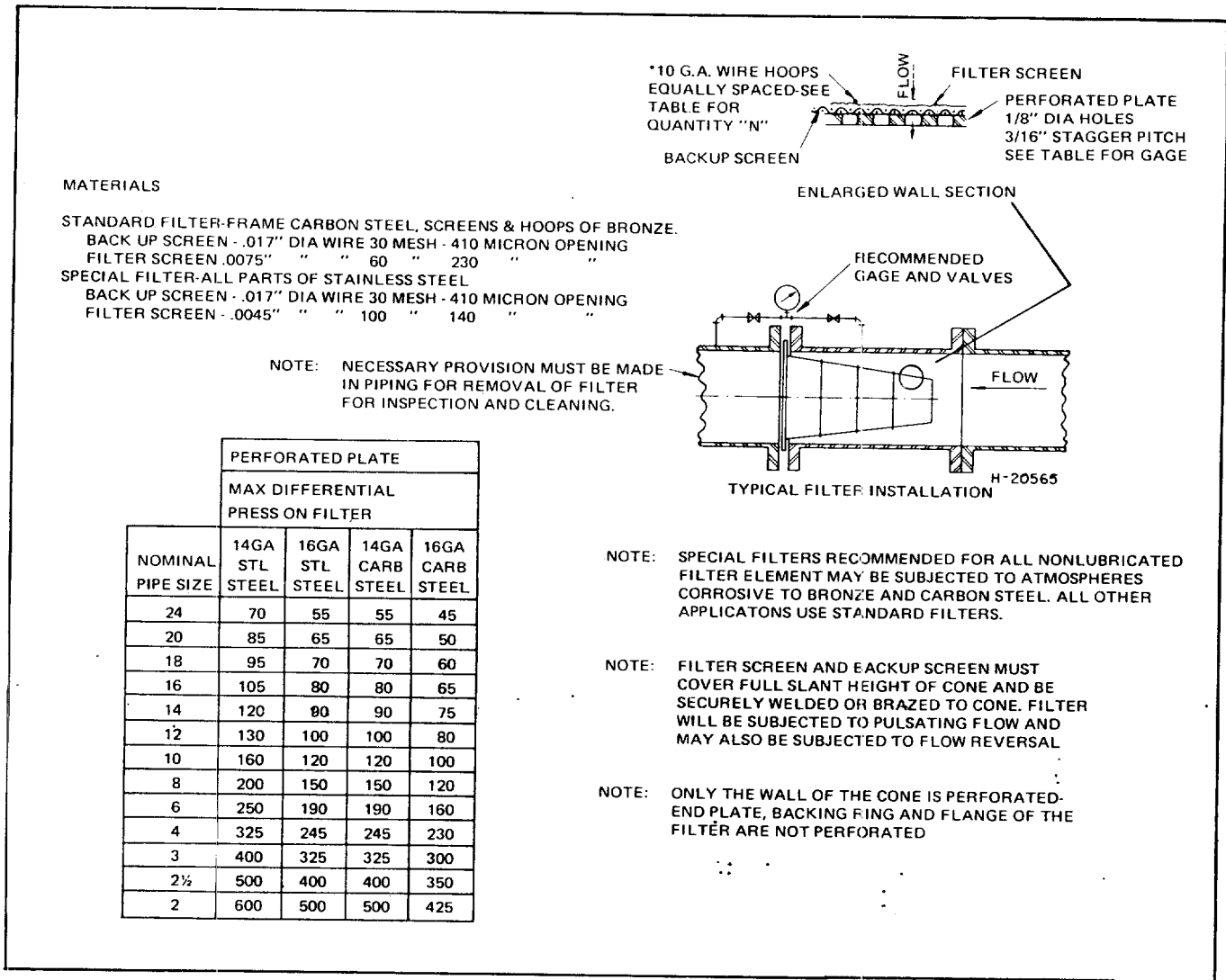

Figure 8. Installation of Line Filter

**Inlet Filter**—An air intake filter is recommended as an excellent investment as it will remove harmful dust and dirt from air that is usually considered clean. Locate the filter, outside, if possible, in an accessible position to facilitate cleaning from time to time. The filter element should be protected from the weather.

Should it be impossible or impractical to run the intake to the outside of the building, and the ambient temperatures are not excessive, the air may be taken into the cylinder directly from the room. However, the room must have adequate ventilation in order for the compressor to operate efficiently.

**DISCHARGE PIPING**

**Compressor**—Discharge piping should be as large as the connection on the cylinder and be as short and direct with as few elbows as possible. It should be well supported to

alleviate strain on the compressor cylinder. Flange gaskets (if applicable) in the discharge line should be of some oil proof material. Care should be taken to assure that the piping and aftercooler are sloped away from the compressor to prevent condensate from draining back and damaging the cylinder.

**CAUTION**

**NEVER INSTALL A SHUT OFF VALVE BETWEEN THE COMPRESSOR AND AIR RECEIVER OR AFTERCOOLER UNLESS A SAFETY VALVE IS PUT IN THE PIPING BETWEEN THE VALVE AND COMPRESSOR.**

**Vacuum Pump**—If the vacuum pump discharges to atmosphere, it should be protected so that moisture, dust, or other waste materials will not carry back into the cylinder. When the vacuum pump handles saturated air at the inlet, considerable condensation often occurs in the discharge pipe. This will eventually become a source of trouble unless precautions are taken to drain the condensation away from the cylinder. Figure 7 illustrates how this can be done.

**Aftercooler and Separator**—An aftercooler is a wise investment and is recommended for most compressor systems. It not only lowers the discharge air temperature, but also used in conjunction with a separator, removes harmful condensation from the air. The aftercooler should be located as close to the compressor as possible and accessible for easy cleaning.

**Receiver**—A receiver is recommended to efficiently control load cycles and minimize air piping pulsation. The receiver can be installed inside or outside but should be placed as close as possible to the aftercooler so as to keep the discharge pipe short. Installing the receiver outside the building aids in radiating some additional heat. However, in colder climates the receiver should be adequately protected from freezing.

**COOLING WATER**

Cooling water removes compression heat from the cylinder and aftercooler. Clean, soft water should be used in cylinder jackets to permit effective heat transfer, minimize plugging of water passages and allow for uniform heat distribution.

Water pressure in the cylinder jacket should not exceed:

Pressure psi (bar)	Cylinder Size (Diameter) inch (millimeter)
75 (5.17)	up to 15 (381)
40 (2.76)	16 to 20 (406 to 508)
30 (2.07)	above 20 (508)

**V-BELT**

Compressor V-Belt drives are often shipped unattached and must be assembled in the field.

1. Thoroughly clean tapered surface of busing and sheave.
2. Coat the outside of the split tapered bushing, the inside diameter of the tapered wheel, hub and portion of the crankshaft where the wheel is assembled, with molybdenum disulfide or white lead and oil to prevent parts seizing.

3. Assemble bushing and sheave as shown in Figure 9. Cap screws should be loosely inserted so that the bushing remains fully expanded to assure a sliding fit on shaft. Bushing and sheave should be assembled using mounting style 1 or 2 depending on distance required from compressor centerline to side of sheave, as shown on foundation plan.

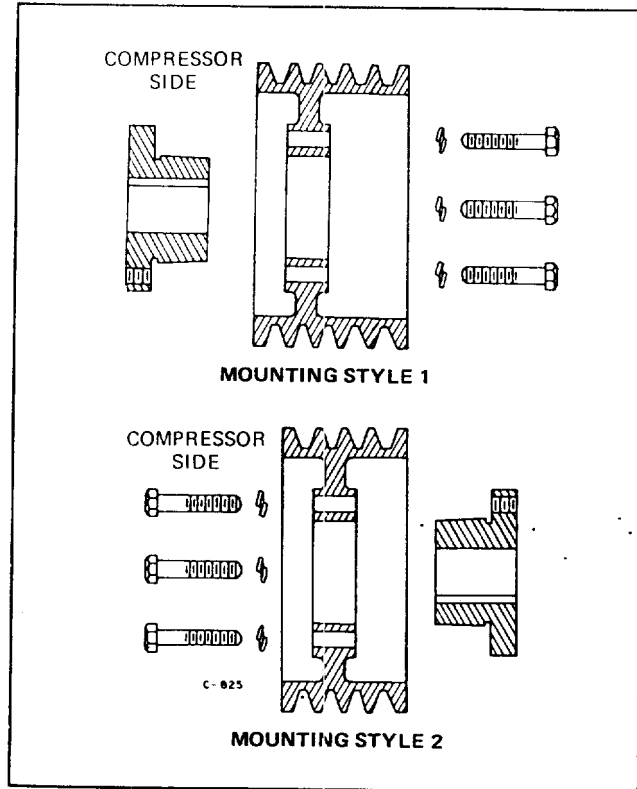

Figure 9. Assembly of Sheave and Bushing

4. With the key in position, slide the sheave on to the crankshaft to the dimension given on the foundation plan. Tighten bushing screws evenly and progressively. Never allow the sheave to be drawn in contact with flange of bushing. This gap should be from 1/8" to 1/4" (3.18 to 6.35 mm).
5. On package units the complete V-belt drive is installed by the factory. If any of the components have to be removed in the field, care should be taken to reinstall the parts in their original position.

**Electrical**—Wiring diagrams may be found in Sections 8A through 8C of the Maintenance Instructions. All wiring should be in accordance with sound practice and state and local codes.



## SECTION IV GENERAL INFORMATION

### COMPRESSOR ACCESSORIES

**Solenoid Operated Water Valve\*\***—Automatically shuts off cooling water when compressor is stopped. Required with dual control or tendamatic-located in water inlet line.

**Safety Valve\*\***—Each compressor discharge line should have at least one safety valve between the compressor discharge connection and the first air line valve. The standard air receiver safety valve provides this protection only if no air line valves are located in the piping between the compressor discharge and the receiver.

**High Discharge Air Temperature Shutdown Switch\*\***—Automatically stops compressor in event of high discharge air temperature. Located in customer discharge piping as close to the compressor as possible.

**Low Cooling Water Pressure Shutdown Switch**—Automatically stops compressor in event of low cooling water pressure. Located in water inlet line.

**Lubricator Line Alert Switch\***—Can be wired to motor shutdown circuit or adapted to visual or audible signal to indicate loss of cylinder lubricator oil flow.

**Thermostatic Water Control Valve**—Used to maintain optimum water flow and constant water temperature consistent with compressor demand.

**Lubricator Heater\***—Installed in the lubricator reservoir. Recommended when ambient temperature at compressor could result in poor oil flow.

**Crankcase Heater\***—Inserted in the crankcase. Recommended when ambient temperature at compressor could result in poor oil flow.

**Cylinder Jacket Water Heater\***—To maintain cylinder wall temperature above ambient during compressor shut down to prevent moisture condensation and subsequent corrosion. To prevent cylinder jacket water from freezing on outdoor installation. Mounted in cylinder or water piping depending on cylinder desing. Cylinder jacket water heaters are recommended by Ingersoll-Rand Company for NL compressors.

**Vibration Switch\***—Automatically will shut the machine down when vibration reaches an unsafe level. Cylinder mounted.

**Closed Sight Flow Indicator**—A visual check on water flow in a closed system. Located in water discharge piping.

**High Oil Temperature Shutdown Switch\***—Automatically stops compressor in the event of high frame oil temperature located on the compressor frame.

\*\* COMPRESSOR ACCESSORIES WHICH ARE STANDARD ON PACKAGE UNITS.

\* THESE ITEMS ARE FACTORY MOUNTED.

**Dual Control Regulation\*\***—Permits the operation of a compressor with either constant speed regulation or automatic-start and stop regulation.

**Tendamatic Control Panel**—Is an operator's control panel also a warning and protection system which provides the highest possible automatic control of your compressor.

### PACKAGE UNIT INSTALLATION

With the purchase of a package air plant, you have all the advantages of the frame grouted compressor plus the convenience of having the compressor and all its system components mounted upon a single sub-base. Follow the installation instructions from pages 3 to 7 to obtain a suitable foundation for your package unit. The exact terminology of the frame grouted compressor and sub-base grouted compressor may vary slightly. The correct word or phrase for the installation of a sub-base mounted compressor will follow immediately in parentheses ( ). Once a suitable foundation has been erected, connect your package air plant by completing the following five steps.

1. Electrical wiring of the correct size to carry the voltage designated on the control panel nameplate must be installed.

All electrical wiring should be installed to comply with local and national electrical codes. A disconnect switch or circuit breaker is required in the electrical supply line leading to the compressor.

2. Connect cooling water inlet and discharge piping. REFER TO COMPRESSOR FOUNDATION PLAN FOR PIPING LOCATIONS.
  - a. The water inlet connection leads through the water solenoid valve to the aftercooler.
  - b. The cooling water is discharged from the top of the compressor cylinder head.
  - c. A drain line is provided from the condensate trap.
3. An air intake filter and silencer is mounted on the compressor. However, it may be desirable to pipe the air intake to an outside source to allow cooler inlet air. If this is done, a filter adapted for outside use should be purchased and it should be installed within a hood to shelter it from the weather.
4. The air discharge connection, located in the receiver tank, is provided for connecting the package unit to the plant air line.

TYPICAL AIR PIPING SCHEMATIC

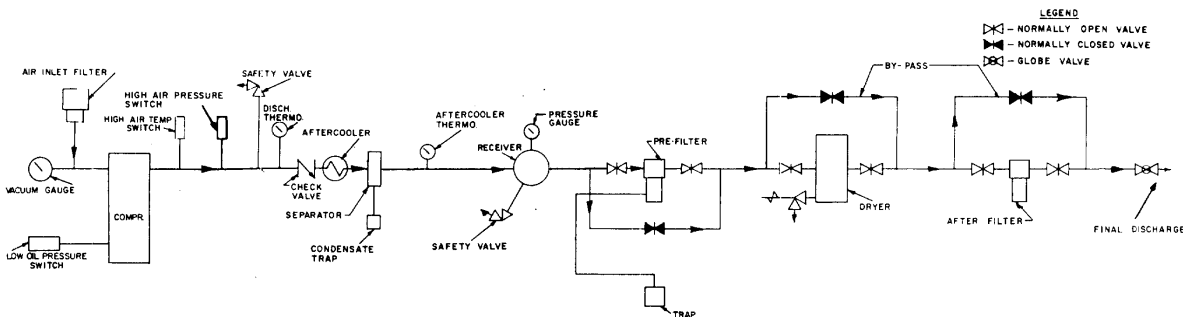

TYPICAL WATER PIPING

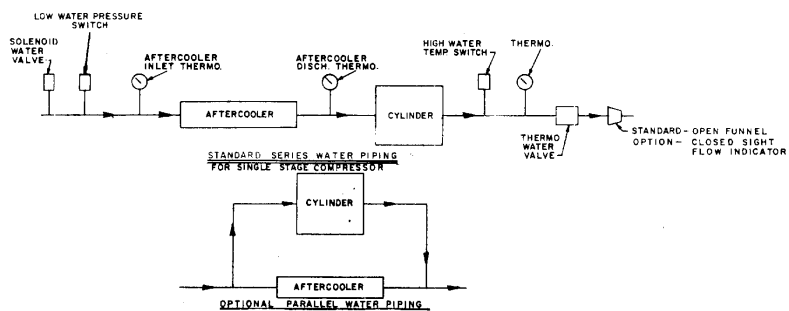

H-4/221

Typical Air Piping Schematic For Single Stage Compressor

Typical Air Piping Schematic For Two Stage Compressor

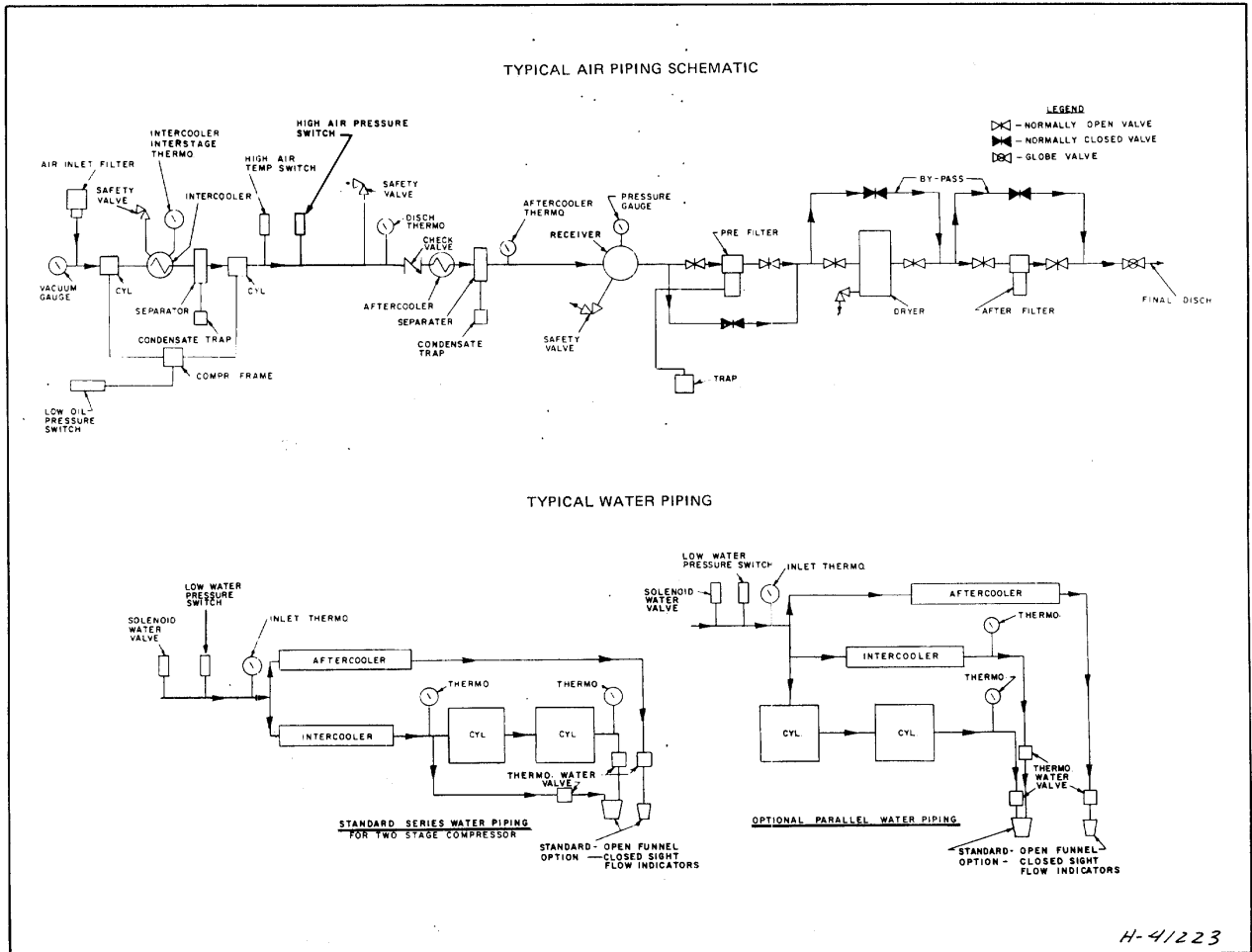

**Special  
Engineering Service**

We can help you with your compressed air problems by surveying your needs and recommending the proper compressor and air piping system for maximum efficiency.

Approved For Release 2007/09/08 : CIA-RDP02-06298R000900030006-6

We stock genuine I-R spare parts for your I-R equipment, avoiding possible costly delays or the substitution of inferior parts kept in good-as-new condition.

**Field Service**

We maintain a staff of trained mechanics and service trucks to provide you with preventive maintenance or meet any emergencies you may have.

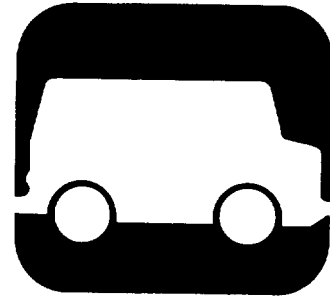
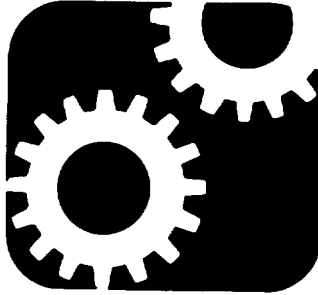
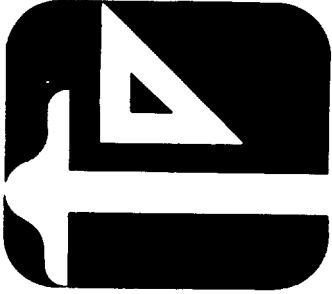

**A world of  
experience...  
at your  
service!**

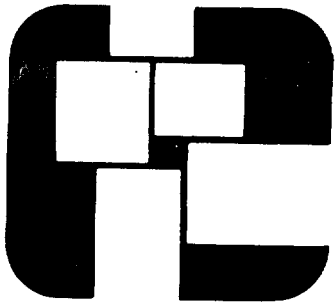

**Complete  
Stock of Equipment**

Our stock of complete machines, which can usually take care of any need, is backed up by Ingersoll-Rand prompt factory shipment to assure you on-time delivery.

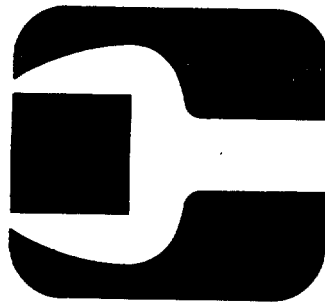

**Complete  
Repair Service**

Trained mechanics will repair or overhaul compressors by factory recommended methods, using only genuine parts.

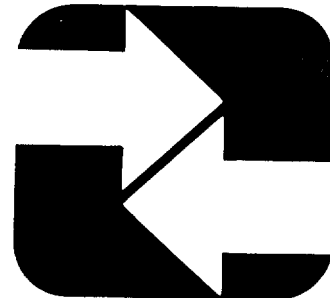

**Exchange  
Service Plan**

We maintain stocks of compressors that can be substituted for your compressor while repairs are being made. This means no lost production time for you.

**INGERSOLL-RAND®**  
**AIR COMPRESSORS**